

Product Specification

## SPECIFICATION FOR APPROVAL

- ( ) Preliminary Specification  
(●) Final Specification

Title	27" Full HD TFT LCD
-------	---------------------



BUYER	HP
MODEL	

SUPPLIER	LG. Display Co., Ltd.
*MODEL	LM270WF1
SUFFIX	TLC1

\*When you obtain standard approval,  
please use the above model name without suffix

APPROVED BY	SIGNATURE DATE
/	
/	
/	

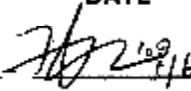
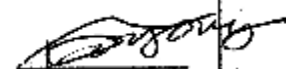
Please return 1 copy for your confirmation with  
your signature and comments.

APPROVED BY	SIGNATURE DATE
H.S. Kim / G.Manager	 10/16
<b>REVIEWED BY</b>	
D.Y. Kim / Manager	
<b>PREPARED BY</b>	
J.H. Kim / Engineer	 09.05.08

**MNT Products Engineering Dept.**  
**LG. Display LCD Co., Ltd**

**Product Specification**
Contents

No	ITEM	Page
	COVER	1
	CONTENTS	2
	RECORD OF REVISIONS	3
1	GENERAL DESCRIPTION	4
2	ABSOLUTE MAXIMUM RATINGS	5
3	ELECTRICAL SPECIFICATIONS	6
3-1	ELECTRICAL CHARACTREISTICS	6
3-2	INTERFACE CONNECTIONS	8
3-3	SIGNAL TIMING SPECIFICATIONS	12
3-4	SIGNAL TIMING WAVEFORMS	13
3-5	COLOR INPUT DATA REFERNECE	14
3-6	POWER SEQUENCE	15
4	OPTICAL SFECIFICATIONS	17
5	MECHANICAL CHARACTERISTICS	23
6	RELIABLITY	26
7	INTERNATIONAL STANDARDS	27
7-1	SAFETY	27
7-2	EMC	27
8	PACKING	28
8-1	DESIGNATION OF LOT MARK	28
8-2	PACKING FORM	28
9	PRECAUTIONS	29

## Product Specification

RECORD OF REVISIONS

Revision No	Revision Date	Page	Description
0.0	Dec. 24. 2008	-	First Draft(Preliminary)
0.1	Mar.03. 2009	8	B/L max power consumption is changed from 93.1 to 91.9watt
			B/L Voltage is Changed (3000/3600 à 2800/3200)
		15	Lamp Connector is changed(C-NET à Yeon-ho)
0.2	Mar.25. 2009	27	Rear View is changed because of Lamp Connector.
		20	Min spec of Viewing angle is changed from 140/130 to 140/140
0.3	Apr.30.2009	20	Color Gamut value is added.
		27	Updated RearView Drawing
		20	Updated Color Coordinates

Product Specification

### 1. General Description

LM270WF1 is a Color Active Matrix Liquid Crystal Display with an integral Cold Cathode Fluorescent Lamp(CCFL) backlight system **without inverter**. The matrix employs a-Si Thin Film Transistor as the active element. It is a transmissive type display operating in the normally black mode. It has a 27 inch diagonally measured active display area with Full HD resolution (1080 vertical by 1920 horizontal pixel array) Each pixel is divided into Red, Green and Blue sub-pixels or dots which are arranged in vertical stripes. Gray scale or the brightness of the sub-pixel color is determined with a 8-bit gray scale signal for each dot, thus, presenting a palette of more than 16,7M colors with Advanced-FRC (Frame Rate Control). . It has been designed to apply the interface method that enables low power, high speed, low EMI. FPD Link or compatible must be used as a LVDS (Low Voltage Differential Signaling) chip. It is intended to support applications where thin thickness, wide viewing angle, low power are critical factors and graphic displays are important. It is intended to support displays where high brightness, super wide viewing angle, high color saturation, and high color are important.

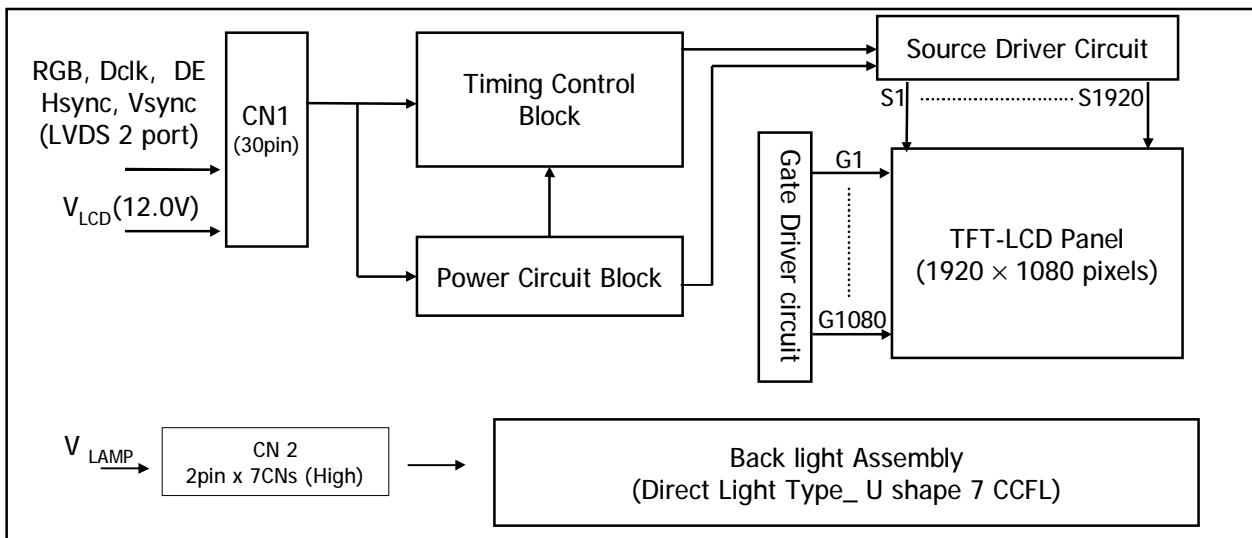

Figure 1. Block diagram

### General Features

Active Screen Size	27 inches(68.6cm) diagonal
Outline Dimension	630(H) x 368.2(V) x 37.2(D) mm(Typ.) *Without Inverter
Pixel Pitch	0.3114 mm x 0.3114 mm
Pixel Format	1920 horiz. By 1080 vert. Pixels RGB stripes arrangement
Color Depth	8-bit with A-FRC, 16,777,216 colors
Luminance, White	400 cd/m <sup>2</sup> (Center 1 point)
Viewing Angle(CR>10)	View Angle Free (R/L 170(Typ.), U/D 160(Typ.))
Power Consumption	Total 87.8 Watt (Typ.) ( 4.2 Watt @V <sub>LCD</sub> , 83.6 Watt @400cd/m <sup>2</sup> )
Weight	4220 g (typ.)
Display Operating Mode	Transmissive mode, normally White
Surface Treatment	Glare treatment of the front polarizer

Product Specification

## 2. Absolute Maximum Ratings

The following are maximum values which, if exceeded, may cause faulty operation or damage to the unit.

Table 1. ABSOLUTE MAXIMUM RATINGS

Parameter	Symbol	Values		Units	Notes
		Min	Max		
Power Input Voltage	V <sub>LCD</sub>	-0.3	12.4	V <sub>dc</sub>	at 25 ± 2°C
Operating Temperature	T <sub>OP</sub>	0	50	°C	1
Storage Temperature	T <sub>ST</sub>	-20	60	°C	
Operating Ambient Humidity	H <sub>OP</sub>	10	90	%RH	
Storage Humidity	H <sub>ST</sub>	10	90	%RH	

Note : 1. Temperature and relative humidity range are shown in the figure below.  
Wet bulb temperature should be 39 °C Max, and no condensation of water.

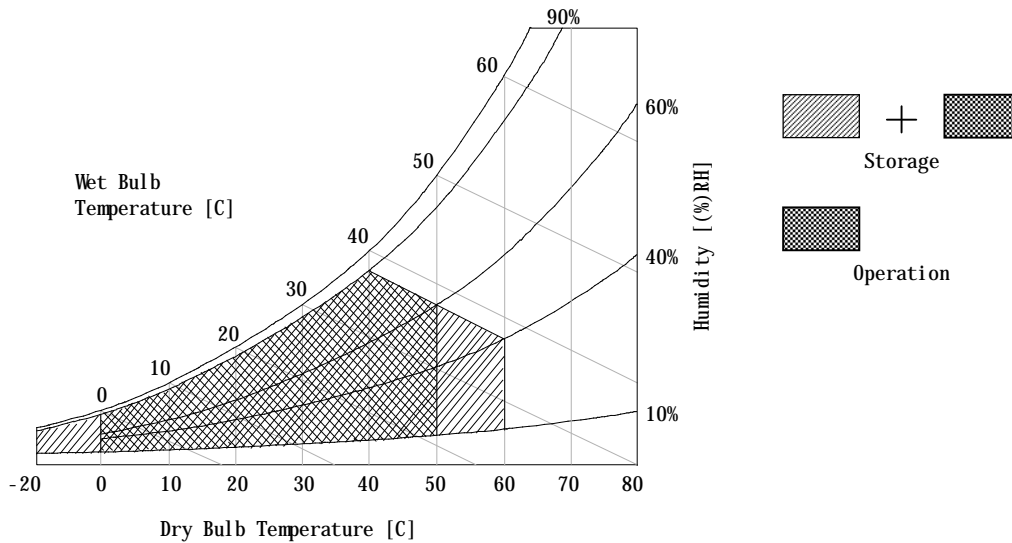

Figure 2. Temperature and relative humidity

Product Specification

### 3. Electrical Specifications

#### 3-1. Electrical Characteristics

It requires two power inputs. One is employed to power the LCD electronics and to drive the TFT array and liquid crystal. The second input power for the CCFL, is typically generated by an inverter. The inverter is an external unit to the LCDs.

Table 2-1. ELECTRICAL CHARACTERISTICS

Parameter	Symbol	Values			Unit	Notes	
		Min	Typ	Max			
MODULE :							
Power Supply Input Voltage	V <sub>LCD</sub>	11.6	12.0	12.4	Vdc		
Permissive Power Input Ripple	V <sub>dRF</sub>			400	mV <sub>p-p</sub>	1	
Differential Impedance	Z <sub>m</sub>	90	100	110	Ohm		
Normal status	Power Supply Input Current	I <sub>LCD</sub>	-	350	403	mA	2
		I <sub>LCD</sub>	-	490	565	mA	3
	Power Consumption	P <sub>c</sub> TYP	-	4.2	4.84	Watt	2
		P <sub>c</sub> MAX	-	5.88	7.02	Watt	3
BDI Status	Power Supply Input Current	I <sub>LCD</sub>	-	500	575	mA	2
		I <sub>LCD</sub>	-	510	590	mA	3
	Power Consumption	P <sub>c</sub> TYP	-	6.0	6.9	Watt	2
		P <sub>c</sub> MAX	-	6.12	7.08	Watt	3
Rush current	I <sub>RUSH</sub>	-	-	3.0	A	4	

Note :

1. Permissive power ripple should be measured under V<sub>CC</sub>=12.0V, 25°C, f<sub>V</sub>(frame frequency)=MAX condition and At that time, we recommend the bandwidth configuration of oscilloscope is to be under 20Mhz. See the next page.
2. The specified current and power consumption are under the V<sub>LCD</sub>=12.0V, 25 ± 2°C, f<sub>V</sub>=60Hz condition whereas Mosaic and max power pattern shown in the [ Figure 3 ] is displayed.
3. The current is specified at the maximum current pattern.
4. Maximum Condition of Inrush current :  
The duration of rush current is about 2ms and rising time of Input Voltage is 1ms(min.).  
At any rising time of Input voltage, Keep the I<sup>2</sup>T Value by below Condition  
Condition : I<sup>2</sup>T < 32\*2ms

## Product Specification

- **Permissive Power input ripple** ( $V_{CC}=12.0V$ ,  $25^{\circ}C$ ,  $f_V$ (frame frequency)=MAX condition)

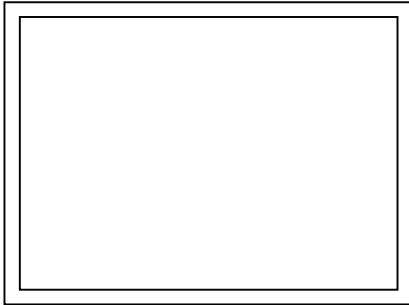
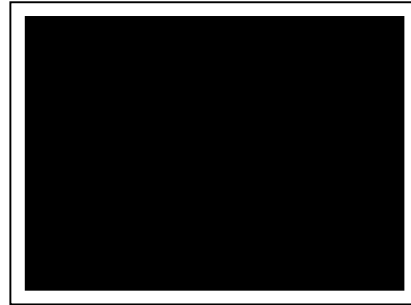
**White pattern****Black pattern**

- **Power consumption** ( $V_{CC}=12.0V$ ,  $25^{\circ}C$ ,  $f_V$  (frame frequency)=60Hz condition)

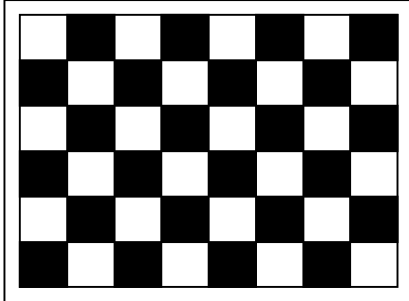
**Typical power Pattern****Max power Pattern****Figure 3. Mosaic pattern & Black Pattern for power consumption measurement**

Product Specification

Table 2\_2. ELECTRICAL CHARACTERISTICS

Parameter	Symbol	Values			Unit	Notes
		Min	Typ	Max		
LAMP :						
Operating Voltage	V <sub>BL</sub>	1900(7.0mA)	1990(6.0mA)	2250(3.0mA)	V <sub>RMS</sub>	1, 2
Operating Current	I <sub>BL</sub>	3.0	6.0	7.0	mA <sub>RMS</sub>	1
Established Starting Voltage	V <sub>S</sub>					1, 3
	at 25 °C	-	-	2800	V <sub>RMS</sub>	
	at 0 °C	-	-	3200	V <sub>RMS</sub>	
Operating Frequency	f <sub>BL</sub>	40	-	80	kHz	4
Discharge Stabilization Time	T <sub>S</sub>			3.0	Min	1, 5
Power Consumption	P <sub>BL</sub>		83.6	91.9	Watt	6
Life Time		40,000			Hrs	1, 7

Note : The design of the inverter must have specifications for the lamp in LCD Assembly.

The performance of the Lamp in LCM, for example life time or brightness, is extremely influenced by the characteristics of the DC-AC inverter. So all the parameters of an inverter should be carefully designed so as not to produce too much leakage current from high-voltage output of the inverter.

When you design or order the inverter, please make sure unwanted lighting caused by the mismatch of the lamp and the inverter (no lighting, flicker, etc) never occurs. When you confirm it, the LCD-Assembly should be operated in the same condition as installed in you instrument.

※ Do not attach a conducting tape to lamp connecting wire.

If the lamp wire attach to a conducting tape, TFT-LCD Module has a low luminance and the inverter has abnormal action. Because leakage current is occurred between lamp wire and conducting tape.

- Specified values are for a single lamp.
- Operating voltage is measured at 25±2°C, and follows as below condition.
  - ±10%@typical operating voltage is based on single lamp.
  - ±20%@typical operating voltage is based on system & test equipment tolerance
- The voltage above V<sub>S</sub> should be applied to the lamps for more than 1 second for start-up. (Inverter open voltage must be more than lamp starting voltage.)  
Otherwise, the lamps may not be turned on. The used lamp current is the lamp typical current.
- Lamp frequency may produce interface with horizontal synchronous frequency and as a result this may cause beat on the display. Therefore lamp frequency shall be as away possible from the horizontal synchronous frequency and from its harmonics in order to prevent interference.
- Let's define the brightness of the lamp after being lighted for 5 minutes as 100%.  
T<sub>S</sub> is the time required for the brightness of the center of the lamp to be not less than 95%.
- The lamp power consumption shown above does not include loss of external inverter.  
The used lamp current is the lamp typical current. (P<sub>BL</sub> = V<sub>BL</sub> × I<sub>BL</sub> × N<sub>Lamp</sub> )
- The life is determined as the time at which brightness of the lamp is 50% compared to that of initial value at the typical lamp current on condition of continuous operating at 25 ± 2°C.



Product Specification

8. The output of the inverter must have symmetrical(negative and positive) voltage waveform and symmetrical current waveform (Unsymmetrical ratio is less than 10%). Please do not use the inverter which has unsymmetrical voltage and unsymmetrical current and spike wave.

Requirements for a system inverter design, which is intended to have a better display performance, a better power efficiency and a more reliable lamp, are following.

It shall help increase the lamp lifetime and reduce leakage current.

- a. The asymmetry rate of the inverter waveform should be less than 10%.
- b. The distortion rate of the waveform should be within  $\sqrt{2} \pm 10\%$ .

\* Inverter output waveform had better be more similar to ideal sine wave.

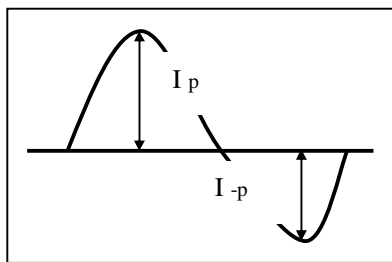

\* Asymmetry rate:

$$\frac{|I_p - I_{-p}|}{I_{rms}} \times 100\%$$

\* Distortion rate

$$I_p \text{ (or } I_{-p}) / I_{rms}$$

- 9. The inverter which is combined with this LCM, is highly recommended to connect coupling(ballast) condenser at the high voltage output side. When you use the inverter which has not coupling(ballast) condenser, it may cause abnormal lamp lighting because of biased mercury as time goes.
- 10. In case of edgy type back light with over 4 parallel lamps, input current and voltage wave form should be synchronized

Product Specification

### 3-2. Interface Connections

This LCD employs Two interface connections, a 30 pin connector is used for the module electronics and a 14Pin Connector is used for the integral backlight system.

#### 3-2-1. LCD Module

- LCD Connector(CN1): KDF71G-30S-1H, (Manufactured by Hirose )
- Mating Connector : FI-X30C2L (Manufactured by JAE) or Equivalent

Table 3 MODULE CONNECTOR(CN1) PIN CONFIGURATION

No	Symbol	Description	No	Symbol	Symbol
1	FR0M	Minus signal of odd channel 0 (LVDS)	16	SR1P	Plus signal of even channel 1 (LVDS)
2	FR0P	Plus signal of odd channel 0 (LVDS)	17	GND	Ground
3	FR1M	Minus signal of odd channel 1 (LVDS)	18	SR2M	Minus signal of even channel 2 (LVDS)
4	FR1P	Plus signal of odd channel 1 (LVDS)	19	SR2P	Plus signal of even channel 2 (LVDS)
5	FR2M	Minus signal of odd channel 2 (LVDS)	20	SCLKINM	Minus signal of even clock channel (LVDS)
6	FR2P	Plus signal of odd channel 2 (LVDS)	21	SCLKINP	Plus signal of even clock channel (LVDS)
7	GND	Ground	22	SR3M	Minus signal of even channel 3 (LVDS)
8	FCLKINM	Minus signal of odd clock channel (LVDS)	23	SR3P	Plus signal of even channel 3 (LVDS)
9	FCLKINP	Plus signal of odd clock channel (LVDS)	24	MPRT	BDI Control (GND: off, 3.3V:on) Notes 4,5,6
10	FR3M	Minus signal of odd channel 3 (LVDS)	25	NC	No Connection
11	FR3P	Plus signal of odd channel 3 (LVDS)	26	NC	No Connection
12	SR0M	Minus signal of even channel 0 (LVDS)	27	DCR_OUT	Dynamic C/R output
13	SR0P	Plus signal of even channel 0 (LVDS)	28	ODC	ODC Control (GND: off, 3.3V:on)
14	GND	Ground	29	V <sub>LCD</sub>	Power Supply +12.0V
15	SR1M	Minus signal of even channel 1 (LVDS)	30	V <sub>LCD</sub>	Power Supply +12.0V

- Note:
1. All GND(ground) pins should be connected together and to V<sub>ss</sub> which should also be connected to the LCD's metal frame.
  2. All V<sub>LCD</sub> (power input) pins should be connected together.
  3. Input Level of LVDS signal is based on the IEA 664 Standard.
  4. MPRT and ODC control does not turn on at same time.
  5. BL is 100% diming at MPRT on status..
  6. On status of MPRT is support dynamic image.

Rear view of LCM



KDF71G-30S-1H



[ Figure 4 ] Connector diagram

**Product Specification**
**Table 4. REQUIRED SIGNAL ASSIGNMENT FOR Flat Link (TI:SN75LVDS83) Transmitter**

Pin #	Pin Name	Require Signal	Pin #	Pin Name	Require Signal
1	Vcc	Power Supply for TTL Input	29	GND	Ground pin for TTL
2	D5	TTL Input (R7)	30	D26	TTL Input (DE)
3	D6	TTL Input (R5)	31	T <sub>X</sub> CLKIN	TTL Level clock Input
4	D7	TTL Input (G0)	32	PWR DWN	Power Down Input
5	GND	Ground pin for TTL	33	PLL GND	Ground pin for PLL
6	D8	TTL Input (G1)	34	PLL Vcc	Power Supply for PLL
7	D9	TTL Input (G2)	35	PLL GND	Ground pin for PLL
8	D10	TTL Input (G6)	36	LVDS GND	Ground pin for LVDS
9	Vcc	Power Supply for TTL Input	37	TxOUT3 +	Positive LVDS differential data output 3
10	D11	TTL Input (G7)	38	TxOUT3 –	Negative LVDS differential data output 3
11	D12	TTL Input (G3)	39	T <sub>X</sub> CLKOUT +	Positive LVDS differential clock output
12	D13	TTL Input (G4)	40	T <sub>X</sub> CLKOUT –	Negative LVDS differential clock output
13	GND	Ground pin for TTL	41	T <sub>X</sub> OUT2 +	Positive LVDS differential data output 2
14	D14	TTL Input (G5)	42	T <sub>X</sub> OUT2 –	Negative LVDS differential data output 2
15	D15	TTL Input (B0)	43	LVDS GND	Ground pin for LVDS
16	D16	TTL Input (B6)	44	LVDS Vcc	Power Supply for LVDS
17	Vcc	Power Supply for TTL Input	45	T <sub>X</sub> OUT1 +	Positive LVDS differential data output 1
18	D17	TTL Input (B7)	46	T <sub>X</sub> OUT1 –	Negative LVDS differential data output 1
19	D18	TTL Input (B1)	47	T <sub>X</sub> OUT0 +	Positive LVDS differential data output 0
20	D19	TTL Input (B2)	48	T <sub>X</sub> OUT0 –	Negative LVDS differential data output 0
21	GND	Ground pin for TTL Input	49	LVDS GND	Ground pin for LVDS
22	D20	TTL Input (B3)	50	D27	TTL Input (R6)
23	D21	TTL Input (B4)	51	D0	TTL Input (R0)
24	D22	TTL Input (B5)	52	D1	TTL Input (R1)
25	D23	TTL Input (RSVD)	53	GND	Ground pin for TTL
26	Vcc	Power Supply for TTL Input	54	D2	TTL Input (R2)
27	D24	TTL Input (HSYNC)	55	D3	TTL Input (R3)
28	D25	TTL Input (VSYNC)	56	D4	TTL Input (R4)

Notes : Refer to LVDS Transmitter Data Sheet for detail descriptions.

Product Specification

## LVDS Input characteristics

### 1. DC Specification

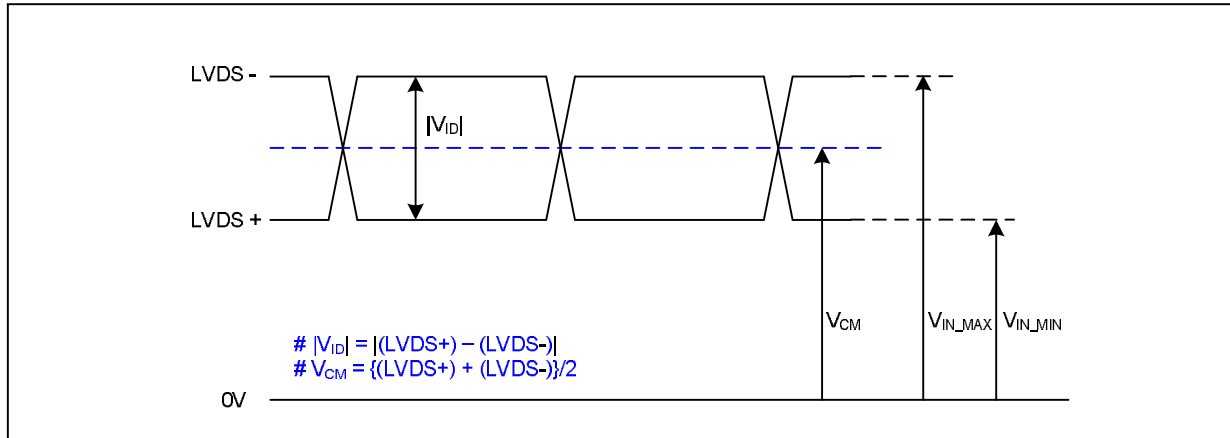

Description	Symbol	Min	Max	Unit	Notes
LVDS Differential Voltage	$ V_{ID} $	100	600	mV	-
LVDS Common mode Voltage	$V_{CM}$	0.6	1.8	V	-
LVDS Input Voltage Range	$V_{IN}$	0.3	2.1	V	-

### 2. AC Specification

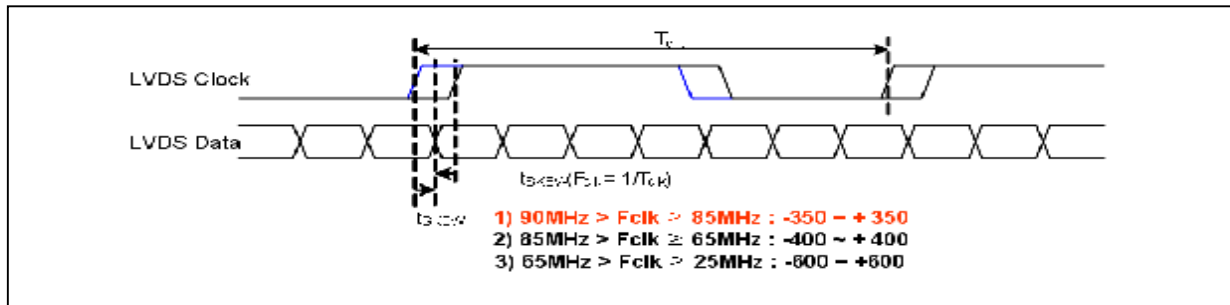

Description	Symbol	Min	Max	Unit	Notes
LVDS Clock to Data Skew Margin	$t_{SKEW}$	-350	+350	Ps	90MHz > Fclk ≥ 85MHz
	$t_{SKEW}$	-400	+400	ps	85MHz > Fclk ≥ 65MHz
	$t_{SKEW}$	-600	+600	ps	65MHz > Fclk ≥ 25MHz
LVDS Clock to Clock Skew Margin (Even to Odd)	$t_{SKEW\_EO}$	-1/7	+1/7	$T_{clk}$	-
Maximum deviation of input clock frequency during SSC	$F_{DEV}$	-	± 3	%	-
Maximum modulation frequency of input clock during SSC	$F_{MOD}$	-	200	KHz	-

Product Specification

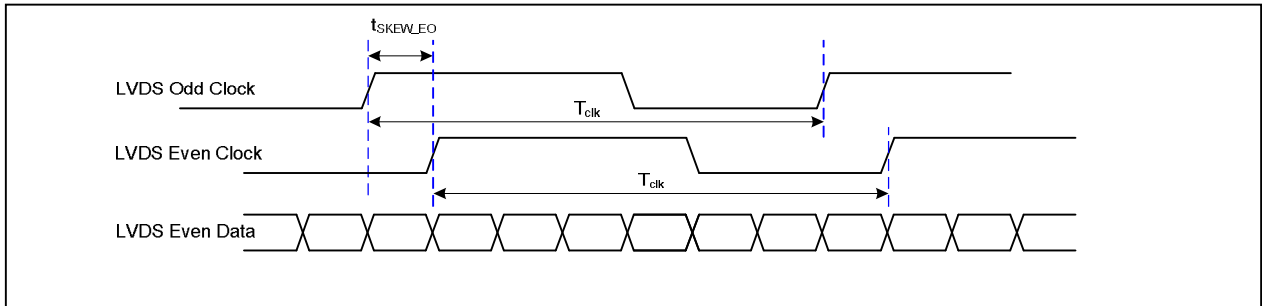

< Clock skew margin between channel >

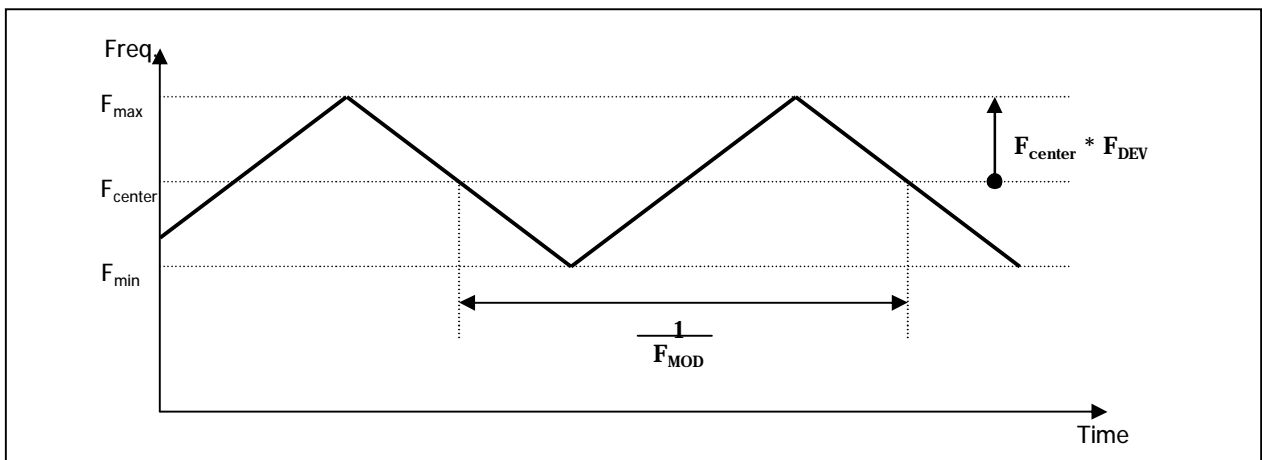

< Spread Spectrum >

3. Data Format

1) LVDS 2 Port

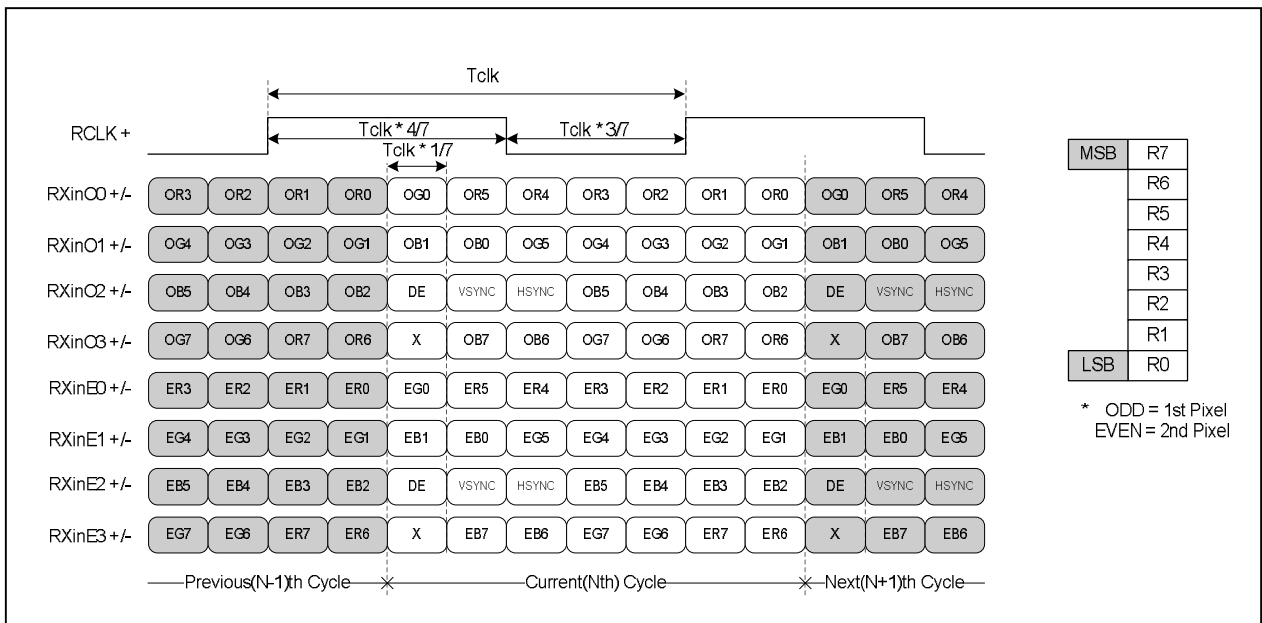

MSB	R7
	R6
	R5
	R4
	R3
	R2
	R1
LSB	R0

\* ODD = 1st Pixel  
EVEN = 2nd Pixel

< LVDS Data Format >

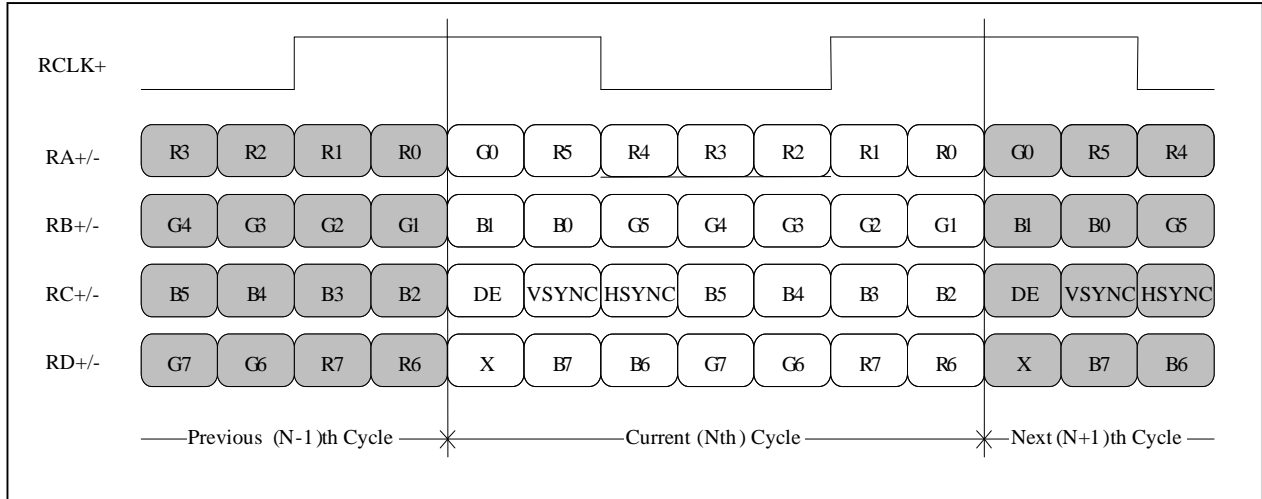
**Product Specification**
**2) LVDS 1 Port**

Product Specification

**Table 5. BACKLIGHT CONNECTOR PIN CONFIGURATION(CN1,CN2,CN3,CN4,CN5,CN6, CN7)**

The backlight interface connector is a model **20015HS-04L** (CN1/CN2/CN3/CN4/CN5/CN6/CN7) manufactured by **Yeon Ho Electronics**. The mating connector part number are **20015WR-07L01**(manufactured by **Yeon Ho Electronics**) or equivalent. The pin configuration for the connector is shown in the table below.

Pin	Symbol	Description	NOTES
1,2	HV	High Voltage for Lamp	1

Note : 1. The high voltage power terminal is colored Red/White

<BACKLIGHT CONNECTOR DIAGRAM>

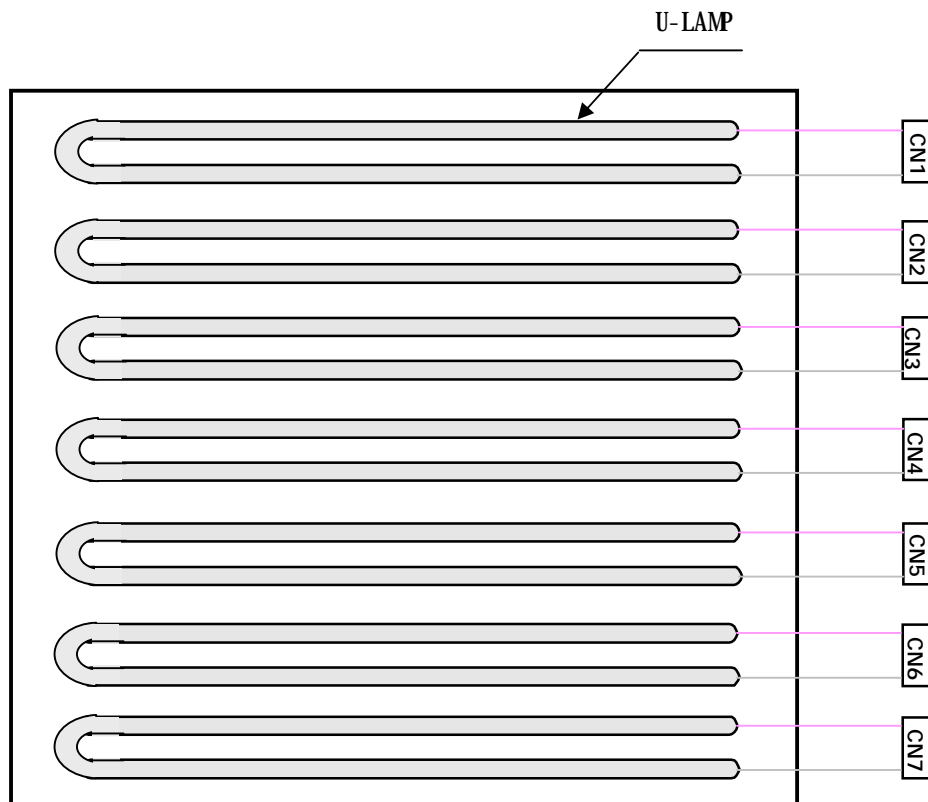

**Product Specification**
**3-3. Signal Timing Specifications**

This is signal timing required at the input of the TMDS transmitter. All of the interface signal timing should be satisfied with the following specifications for it's proper operation.

**Table 5. TIMING TABLE**

ITEM	Symbol		Min	Typ	Max	Unit	Note
DCLK	Period	tCLK	11.76	13.89	15.38	ns	
	Frequency	-	65	72	90	MHz	
Hsync	Period	tHP	1018	1088	1120	tCLK	
	Horizontal Valid	tHV	960	960	960	tCLK	
	Horizontal Blank	tHB	58	128	160		
	Frequency	fH	64	66	88	KHz	
	Width	tWH	18	32	48	tCLK	
	Horizontal Back Porch	tHBP	20	48	64		
	Horizontal Front Porch	tHFP	20	48	48		
Vsync	Period	tVP	1087	1100	1250	tHP	
	Vertical Valid	tVV	1080	1080	1080	tHP	
	Vertical Blank	tVB	7	20	170	tHP	
	Frequency	fV	50	60	75	Hz	
	Width	tWV	1	4	42	tHP	
	Vertical Back Porch	tVBP	5	8	64		
	Vertical Front Porch	tVFP	1	8	64		

Note: Hsync period and Hsync width-active should be even number times of tCLK. If the value is odd number times of tCLK, display control signal can be asynchronous. In order to operate this LCM a Hsync, Vsyn, and DE(data enable) signals should be used.

1. The performance of the electro-optical characteristics may be influenced by variance of the vertical refresh rates.
2. Vsync and Hsync should be keep the above specification.
3. Hsync Period, Hsync Width, and Horizontal Back Porch should be any times of of character number(8).
4. The polarity of Hsync, Vsync is not restricted.
5. BDI on status : Vsync opearte at 60hz



Product Specification

3-4. Signal Timing Waveforms

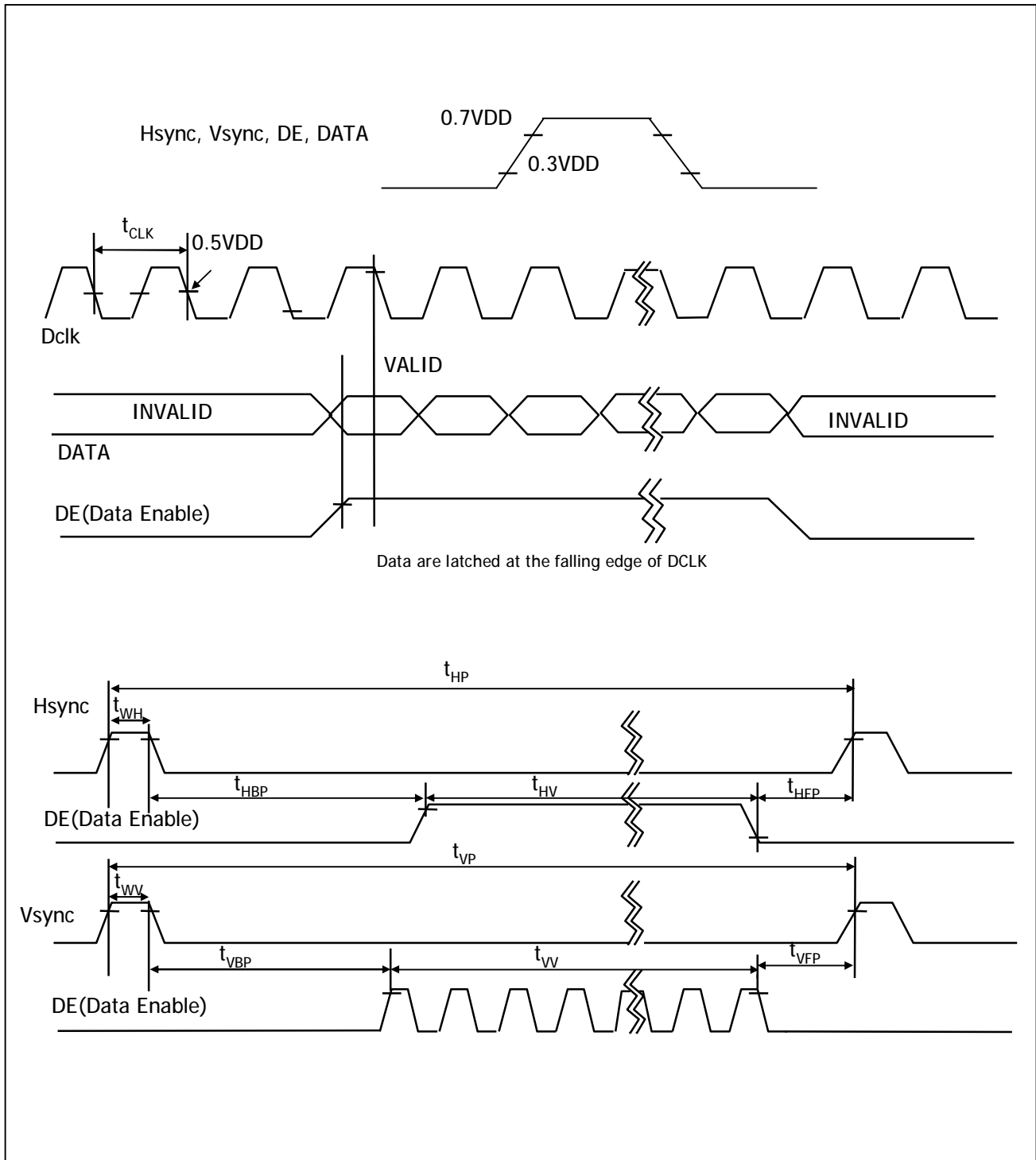

**Product Specification**

### 3-5. Color Data Reference

The Brightness of each primary color(red,green,blue) is based on the 8-bit gray scale data input for the color; the higher the binary input, the brighter the color. The table below provides a reference for color versus data input.

**Table 6. COLOR DATA REFERENCE**

Color		Input Color Data																							
		RED								GREEN								BLUE							
		MSB				LSB				MSB				LSB				MSB				LSB			
		R7	R6	R5	R4	R3	R2	R1	R0	G7	G6	G5	G4	G3	G2	G1	G0	B7	B6	B5	B4	B3	B2	B1	B0
Basic Color	Black	0	0	0	0	0	0	0	0	0	0	0	0	0	0	0	0	0	0	0	0	0	0	0	0
	Red (255)	1	1	1	1	1	1	1	1	0	0	0	0	0	0	0	0	0	0	0	0	0	0	0	0
	Green (255)	0	0	0	0	0	0	0	0	1	1	1	1	1	1	1	1	0	0	0	0	0	0	0	0
	Blue (255)	0	0	0	0	0	0	0	0	0	0	0	0	0	0	0	0	1	1	1	1	1	1	1	1
	Cyan	0	0	0	0	0	0	0	0	1	1	1	1	1	1	1	1	1	1	1	1	1	1	1	1
	Magenta	1	1	1	1	1	1	1	1	0	0	0	0	0	0	0	0	1	1	1	1	1	1	1	1
	Yellow	1	1	1	1	1	1	1	1	1	1	1	1	1	1	1	1	0	0	0	0	0	0	0	0
	White	1	1	1	1	1	1	1	1	1	1	1	1	1	1	1	1	1	1	1	1	1	1	1	1
RED	RED (000) Dark	0	0	0	0	0	0	0	0	0	0	0	0	0	0	0	0	0	0	0	0	0	0	0	0
	RED (001)	0	0	0	0	0	0	0	1	0	0	0	0	0	0	0	0	0	0	0	0	0	0	0	0
	...	...								...								...							
	RED (254)	1	1	1	1	1	1	1	0	0	0	0	0	0	0	0	0	0	0	0	0	0	0	0	0
	RED (255)	1	1	1	1	1	1	1	1	0	0	0	0	0	0	0	0	0	0	0	0	0	0	0	0
GREEN	GREEN (000) Dark	0	0	0	0	0	0	0	0	0	0	0	0	0	0	0	0	0	0	0	0	0	0	0	0
	GREEN (001)	0	0	0	0	0	0	0	0	0	0	0	0	0	0	0	1	0	0	0	0	0	0	0	0
	...	...								...								...							
	GREEN (254)	0	0	0	0	0	0	0	0	1	1	1	1	1	1	1	0	0	0	0	0	0	0	0	0
	GREEN (255)	0	0	0	0	0	0	0	0	1	1	1	1	1	1	1	1	0	0	0	0	0	0	0	0
BLUE	BLUE (000) Dark	0	0	0	0	0	0	0	0	0	0	0	0	0	0	0	0	0	0	0	0	0	0	0	0
	BLUE (001)	0	0	0	0	0	0	0	0	0	0	0	0	0	0	0	0	0	0	0	0	0	0	0	1
	...	...								...								...							
	BLUE (254)	0	0	0	0	0	0	0	0	0	0	0	0	0	0	0	0	1	1	1	1	1	1	1	0
	BLUE (255)	0	0	0	0	0	0	0	0	0	0	0	0	0	0	0	0	1	1	1	1	1	1	1	1

Product Specification

### 3-6. Power Sequence

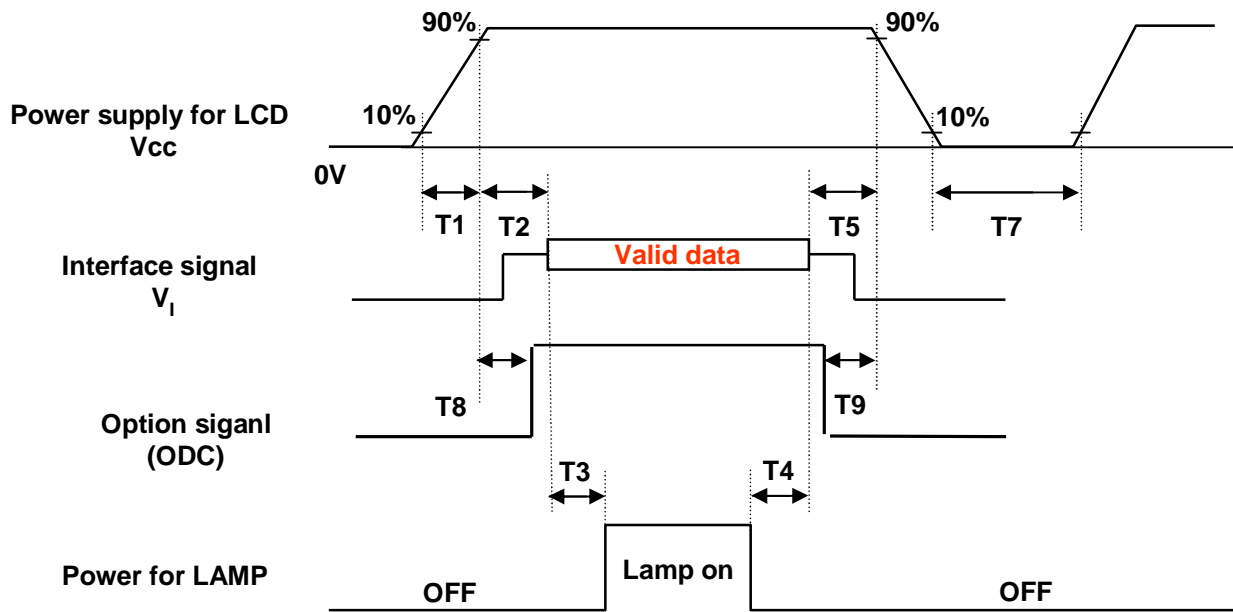

Table 7. POWER SEQUENCE

Parameter	Values			Units
	Min	Typ	Max	
T1	0.5	-	10	ms
T2	0.01	-	50	ms
T3	500	-	-	ms
T4	200	-	-	ms
T5	0.01	-	50	ms
T7	500	-	-	ms
T8	0 < T8 < T2			ms
T9	0 < T9 < T5			ms

- Notes :
1. Please avoid floating state of interface signal at invalid period.
  2. When the interface signal is invalid, be sure to pull down the power supply for LCD  $V_{LCD}$  to 0V.
  3. Lamp power must be turn on after power supply for LCD and interface signal are valid.

Product Specification

#### 4. Optical Specifications

Optical characteristics are determined after the unit has been 'ON' for approximately 30 minutes in a dark environment at  $25 \pm 2^\circ\text{C}$ . The values specified are at an approximate distance 50cm from the LCD surface at a viewing angle of  $\Phi$  and  $\theta$  equal to  $0^\circ$  and aperture 1 degree.

FIG. 1 presents additional information concerning the measurement equipment and method.

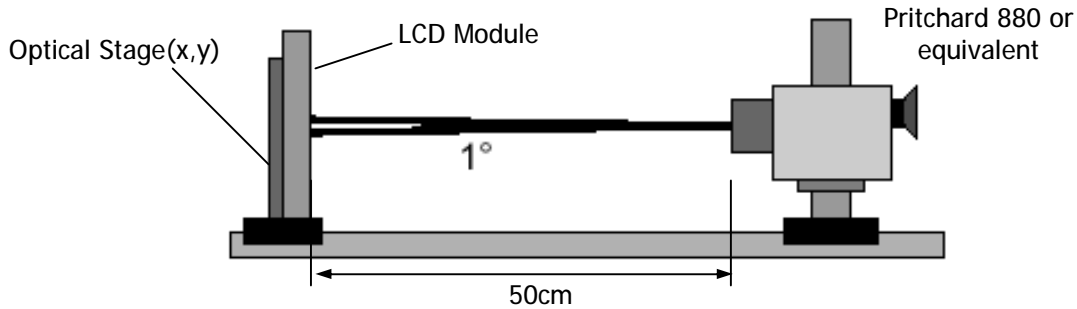

FIG. 6 Optical Characteristic Measurement Equipment and Method

Table 9. OPTICAL CHARACTERISTICS ( $T_a = 25^\circ\text{C}$ ,  $V_{LCD} = 12.0\text{V}$ ,  $f_V = 60\text{Hz}$  Dclk = 144MHz, IBL = 6mA)

Parameter	Symbol	Values			Units	Notes	
		Min	Typ	Max			
Contrast Ratio	CR	700	1000			1	
Surface Luminance, white	$L_{WH}$	320	400		cd/m <sup>2</sup>	2	
Luminance Variation	$\delta_{WHITE}$	75			%	3	
Response Time	Rise Time	$T_{R}$	-	1	4	ms	4
	Decay Time	$T_{D}$	-	4	8	ms	4
	Gray to Gray	$T_{GTG}$		2	6	ms	5
	MPRT	$T_{MPRT}$		10	15	ms	6
Color Coordinates [CIE1931]	RED	$R_x$	Typ -0.03	0.662	Typ +0.03		
		$R_y$		0.318			
	GREEN	$G_x$		0.212			
		$G_y$		0.665			
	BLUE	$B_x$		0.145			
		$B_y$		0.070			
	WHITE	$W_x$		0.313			
	$W_y$	0.329					
Color Gamut	-	-	92	-	%		
Viewing Angle (CR>10)							
	x axis, right( $\phi=0^\circ$ )	$\theta_r$	70	85		Degree	7
	x axis, left ( $\phi=180^\circ$ )	$\theta_l$	70	85			
	y axis, up ( $\phi=90^\circ$ )	$\theta_u$	65	75			
	y axis, down ( $\phi=270^\circ$ )	$\theta_d$	75	85			
Gray Scale			2.2			8	

**Product Specification**

Notes 1. **Contrast Ratio(CR)** is defined mathematically as :

$$\text{Contrast Ratio} = \frac{\text{Surface Luminance with all white pixels}}{\text{Surface Luminance with all black pixels}}$$

2. **Surface luminance** is luminance value at No.1 point across the LCD surface 50cm from the surface with all pixels displaying white. For more information see FIG 6.

3. **The variation in surface luminance , d WHITE** is defined as :

$$d_{\text{WHITE}} = \frac{\text{Minimum}(L_{\text{on}1}, L_{\text{on}2}, \dots, L_{\text{on}9})}{\text{Maximum}(L_{\text{on}1}, L_{\text{on}2}, \dots, L_{\text{on}9})} \times 100(\%)$$

Measuring point for surface luminance & measuring point for luminance variation

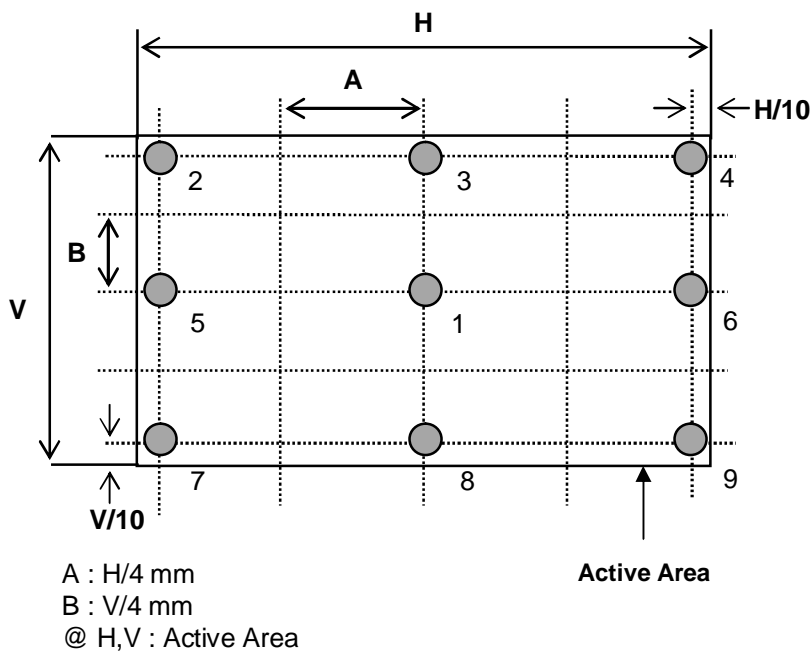

[ FIGURE 7 ] Measure Point for Luminance

Product Specification

4. **The response time** is defined as the following figure and shall be measured by switching the input signal for "black" and "white".  
Response time is the time required for the display to transition from white to black (Rise Time,  $T_{rR}$ ) and from black to white (Decay Time,  $T_{rD}$ ).

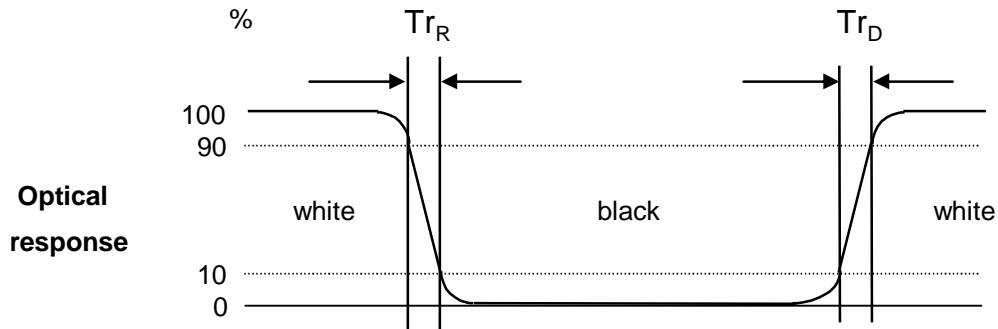

[ FIGURE 8] Response Time

5, The **gray to gray response time** is defined as the following figure and shall be measured by switching the input signal for "Gray To Gray".

- Gray step : 5 step
- $T_{GTG\_AVR}$  is the total average time at rising time and falling time for "Gray To Gray".
- $T_{GTG\_MAX}$  is the max time at rising time or falling time for "Gray To Gray".

Table 10. Gray to gray response time table

Gray to Gray		Rising Time				
		G255	G191	G127	G63	G0
Falling Time	G255					
	G191					
	G127					
	G63					
	G0					

Product Specification

6. MPRT is defined as the 10% to 90% blur-edge width  $B_{ij}$ (pixels) and scroll speed  $U$ (pixels/frame) at the moving picture.

MPRT is defined as 10% to 90% blur-edge with  $B_{ij}$ (pixels) and scroll speed  $U$ (pixels/frame) at the moving picture.

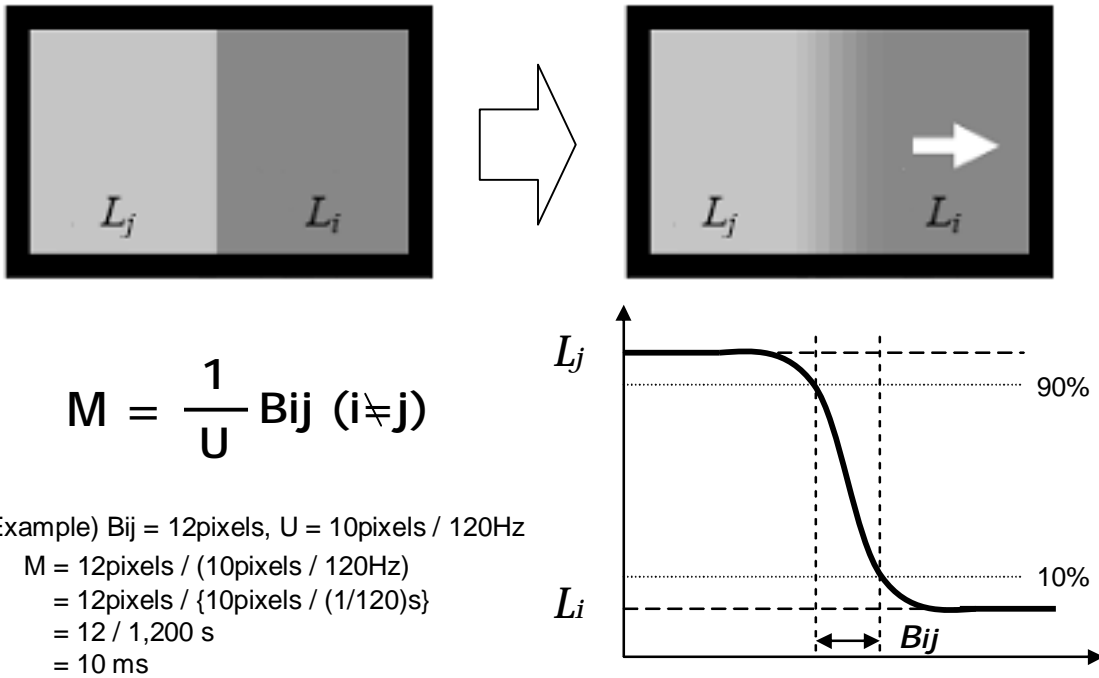

[ FIGURE 9 ] MPRT

Product Specification

7. **Viewing angle** is the angle at which the contrast ratio is greater than 10 or 5. The angles are determined for the horizontal or x axis and the vertical or y axis with respect to the z axis which is normal to the LCD surface. For more information see FIG. 9 .

<Dimension of viewing angle range>

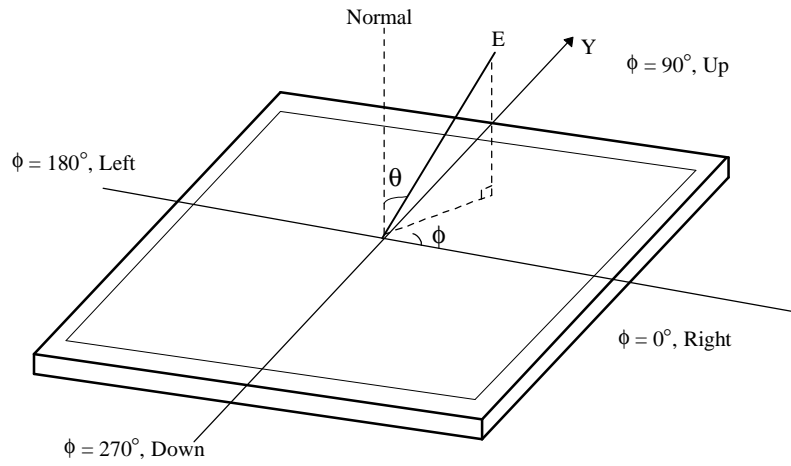

[ FIGURE 10 ] Viewing angle

8, **Gray scale** specification  
Gamma Value is approximately 2.2. For more information see Table 11

**Table 11. Gray Scale Specification**

Gray Level	Relative Luminance [%] (Typ.)
0	0.1
31	1.2
63	4.7
95	11.7
127	21.2
159	35.2
191	53.0
223	75.4
255	100



Product Specification

### 5. Mechanical Characteristics

The contents provide general mechanical characteristics. In addition the figures in the next page are detailed mechanical drawing of the LCD.

Outline Dimension	Horizontal	630mm
	Vertical	368.2mm
	Depth	37.2mm
Bezel Area	Horizontal	602mm
	Vertical	340.4mm
Active Display Area	Horizontal	597.89mm
	Vertical	336.31mm
Weight	Typ : 4220 g , Max : 4430 g	
Surface Treatment	Hard coating(3H) Glare treatment of the front polarizer	

Notes : Please refer to a mechanic drawing in terms of tolerance at the next page.

**Product Specification**

<FRONT VIEW>

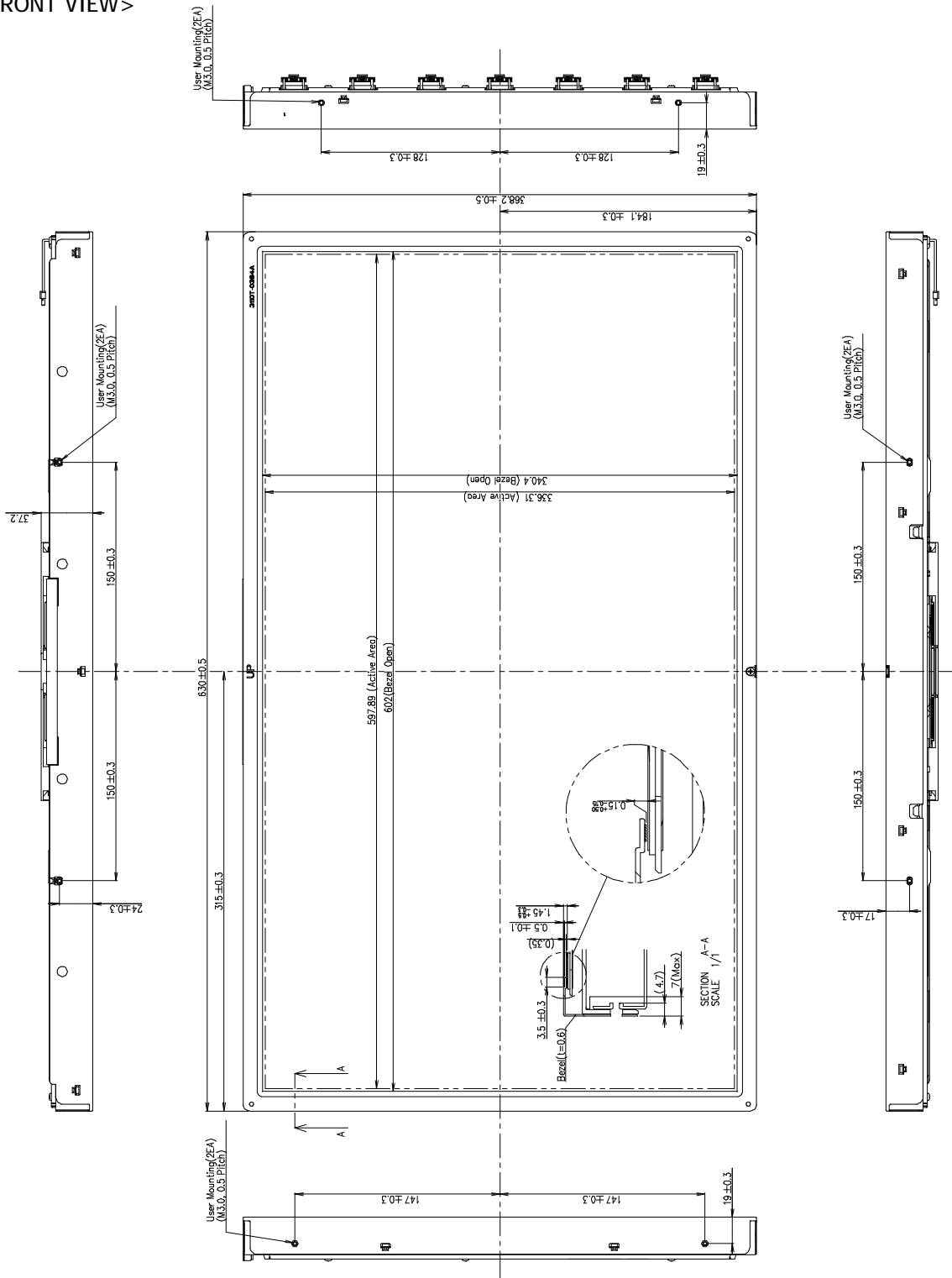

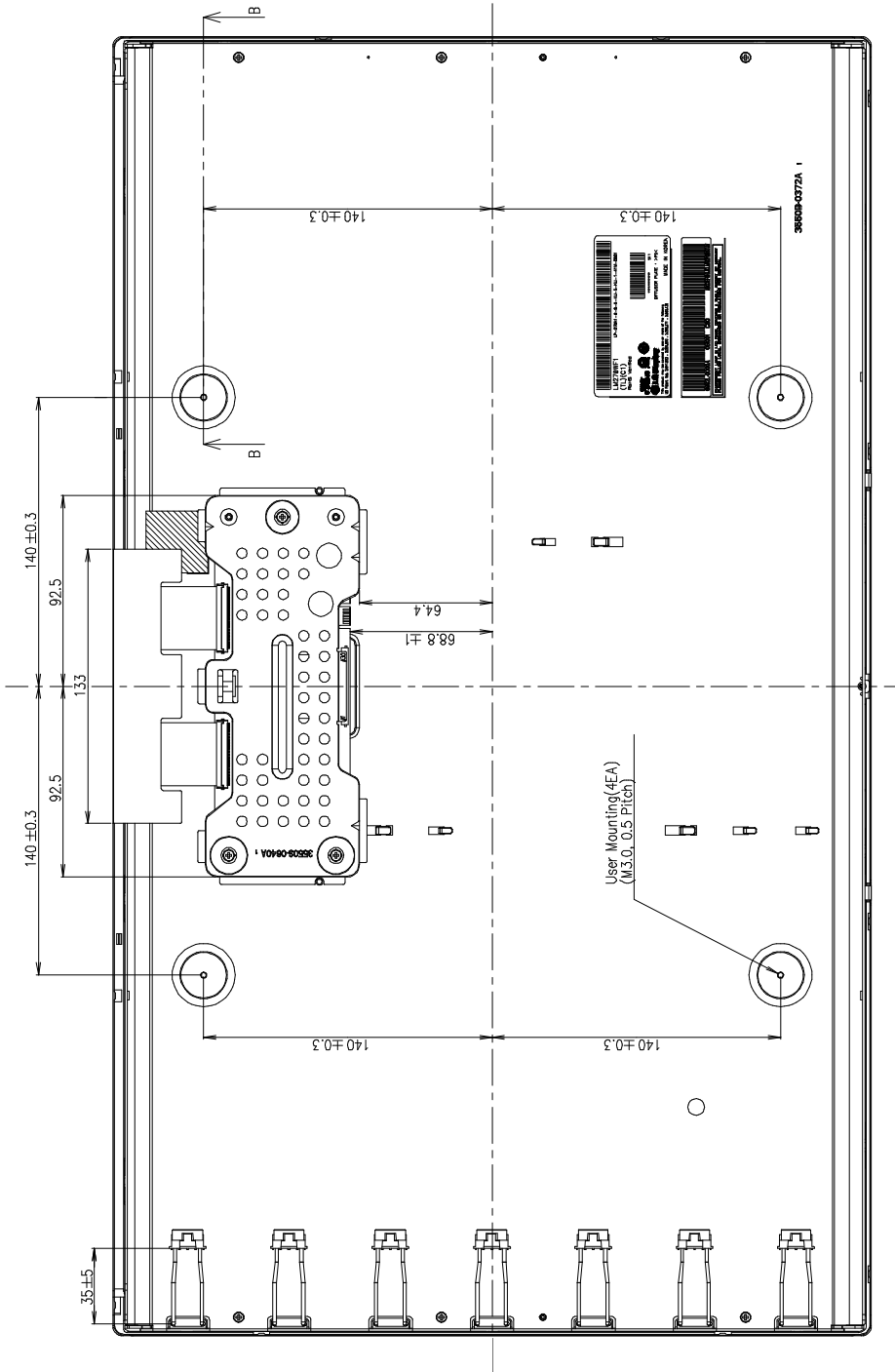
**Product Specification**
**< REAR VIEW >**

- Notes
1. Unspecified tolerances are to be  $\pm 0.5\text{mm}$ .
  2. Tilt and partial disposition tolerance of display area are as following.
    - (1) Y-direction :  $IA-BI \leq 1.4\text{mm}$
    - (2) X-direction :  $IC-DI \leq 1.4\text{mm}$

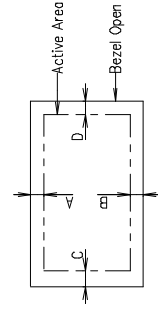

3. Torque SPEC of Mounting :  $6.0 \sim 7.0\text{kgf}\cdot\text{cm}$
4. I/F Connector Specification : KDF7(G-30S-1H)( Hirose ) or Compatible
5. Lamp Connector Specification : 20015HS-04LB( Yeeino ) or Compatible

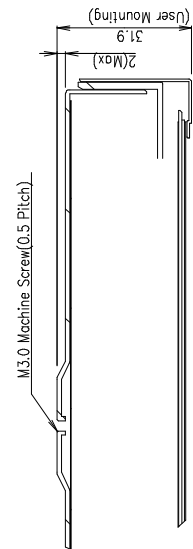
 SECTION B-B  
 SCALE 1/1

Product Specification

## 6. Reliability

Environment test condition

No	Test Item	Condition
1	High temperature storage test	Ta= 60°C 240h
2	Low temperature storage test	Ta= -20°C 240h
3	High temperature operation test	Ta= 50°C 50%RH 240h
4	Low temperature operation test	Ta= 0°C 240h
5	Vibration test (non-operating)	Wave form : random Vibration level : 1.0Grms Bandwidth : 10-300Hz Duration : X,Y,Z, 10min One time each direction
6	Shock test (non-operating)	Shock level : 100G Waveform : half sine wave, 2ms Direction : ±X, ±Y, ±Z One time each direction
7	Humidity condition Operation	Ta= 40 °C ,90%RH
8	Altitude storage / shipment	0 - 40,000 feet(12192m)
9	Maximum Storage Humidity for 4 corner light leakage Mura.	Max 70%RH , Ta=40°C

**Product Specification****7. International Standards****7-1. Safety**

- a) UL 60950-1:2003, First Edition, Underwriters Laboratories, Inc., Standard for Safety of Information Technology Equipment.
- b) CAN/CSA C22.2, No. 60950-1-03 1<sup>st</sup> Ed. April 1, 2003, Canadian Standards Association, Standard for Safety of Information Technology Equipment.
- c) EN 60950-1:2001, First Edition, European Committee for Electro technical Standardization(CENELEC) European Standard for Safety of Information Technology Equipment.

**7-2. EMC**

- a) ANSI C63.4 "Methods of Measurement of Radio-Noise Emissions from Low-Voltage Electrical and Electrical Equipment in the Range of 9kHz to 40GHz." American National Standards Institute(ANSI), 1992
- b) C.I.S.P.R. "Limits and Methods of Measurement of Radio Interface Characteristics of Information Technology Equipment." International Special Committee on Radio Interference.
- c) EN 55022 "Limits and Methods of Measurement of Radio Interface Characteristics of Information Technology Equipment." European Committee for Electro technical Standardization.(CENELEC), 1998 ( Including A1: 2000 )

Product Specification

## 8. Packing

### 8-1. Designation of Lot Mark

a) Lot Mark

A	B	C	D	E	F	G	H	I	J	K	L	M
---	---	---	---	---	---	---	---	---	---	---	---	---

A,B,C : SIZE(INCH)  
E : MONTH

D : YEAR  
F ~ M : SERIAL NO.

Note

1. YEAR

Year	2001	2002	2003	2004	2005	2006	2007	2008	2009	2010
Mark	1	2	3	4	5	6	7	8	9	0

2. MONTH

Month	Jan	Feb	Mar	Apr	May	Jun	Jul	Aug	Sep	Oct	Nov	Dec
Mark	1	2	3	4	5	6	7	8	9	A	B	C

b) Location of Lot Mark

Serial No. is printed on the label. The label is attached to the backside of the LCD module.  
This is subject to change without prior notice.

### 8-2. Packing Form

a) Package quantity in one box : 5EA

b) Box Size : 747X335X466

**Product Specification****9. PRECAUTIONS**

Please pay attention to the followings when you use this TFT LCD module.

**9-1. MOUNTING PRECAUTIONS**

- (1) You must mount a module using holes arranged in four corners or four sides.
- (2) You should consider the mounting structure so that uneven force (ex. Twisted stress) is not applied to the module. And the case on which a module is mounted should have sufficient strength so that external force is not transmitted directly to the module.
- (3) Please attach the surface transparent protective plate to the surface in order to protect the polarizer. Transparent protective plate should have sufficient strength in order to resist external force.
- (4) You should adopt radiation structure to satisfy the temperature specification.
- (5) Acetic acid type and chlorine type materials for the cover case are not desirable because the former generates corrosive gas of attacking the polarizer at high temperature and the latter causes circuit break by electro-chemical reaction.
- (6) Do not touch, push or rub the exposed polarizers with glass, tweezers or anything harder than HB pencil lead. And please do not rub with dust clothes with chemical treatment. Do not touch the surface of polarizer for bare hand or greasy cloth. (Some cosmetics are detrimental to the polarizer.)
- (7) When the surface becomes dusty, please wipe gently with absorbent cotton or other soft materials like chamois soaks with petroleum benzene. Normal-hexane is recommended for cleaning the adhesives used to attach front / rear polarizers. Do not use acetone, toluene and alcohol because they cause chemical damage to the polarizer.
- (8) Wipe off saliva or water drops as soon as possible. Their long time contact with polarizer causes deformations and color fading.
- (9) Do not open the case because inside circuits do not have sufficient strength.

**9-2. OPERATING PRECAUTIONS**

- (1) The spike noise causes the mis-operation of circuits. It should be lower than following voltage :  
 $V = \pm 200\text{mV}$  (Over and under shoot voltage)
- (2) Response time depends on the temperature. (In lower temperature, it becomes longer.)
- (3) Brightness depends on the temperature. (In lower temperature, it becomes lower.)  
And in lower temperature, response time (required time that brightness is stable after turned on) becomes longer.
- (4) Be careful for condensation at sudden temperature change. Condensation makes damage to polarizer or electrical contacted parts. And after fading condensation, smear or spot will occur.
- (5) When fixed patterns are displayed for a long time, remnant image is likely to occur.
- (6) Module has high frequency circuits. Sufficient suppression to the electromagnetic interference shall be done by system manufacturers. Grounding and shielding methods may be important to minimize the interference.
- (7) Please do not give any mechanical and/or acoustical impact to LCM. Otherwise, LCM can't be operated its full characteristics perfectly.
- (8) A screw which is fastened up the steels should be a machine screw.  
(if not, it causes metallic foreign material and deal LCM a fatal blow)
- (9) Please do not set LCD on its edge.

**Product Specification****9-3. ELECTROSTATIC DISCHARGE CONTROL**

Since a module is composed of electronic circuits, it is not strong to electrostatic discharge. Make certain that treatment persons are connected to ground through wrist band etc. And don't touch interface pin directly.

**9-4. PRECAUTIONS FOR STRONG LIGHT EXPOSURE**

Strong light exposure causes degradation of polarizer and color filter.

**9-5. STORAGE**

When storing modules as spares for a long time, the following precautions are necessary.

- (1) Store them in a dark place. Do not expose the module to sunlight or fluorescent light. Keep the temperature between 5°C and 35°C at normal humidity.
- (2) The polarizer surface should not come in contact with any other object.  
It is recommended that they be stored in the container in which they were shipped.

**9-6. HANDLING PRECAUTIONS FOR PROTECTION FILM**

- (1) The protection film is attached to the bezel with a small masking tape.  
When the protection film is peeled off, static electricity is generated between the film and polarizer.  
This should be peeled off slowly and carefully by people who are electrically grounded and with well ion-blown equipment or in such a condition, etc.
- (2) When the module with protection film attached is stored for a long time, sometimes there remains a very small amount of glue still on the bezel after the protection film is peeled off.
- (3) You can remove the glue easily. When the glue remains on the bezel surface or its vestige is recognized, please wipe them off with absorbent cotton waste or other soft material like chamois soaked with normal-hexane.