



**LM270WQ1**  
Liquid Crystal Display

Product Specification

## SPECIFICATION FOR APPROVAL

- ( ) Preliminary Specification  
(●) Final Specification

Title	27.0" QHD TFT LCD
-------	-------------------

BUYER	APPLE
MODEL	K75F

SUPPLIER	LG Display Co., Ltd.
*MODEL	LM270WQ1
SUFFIX	SDC2

\*When you obtain standard approval,  
please use the above model name without suffix

APPROVED BY	SIGNATURE DATE
/	_____
/	_____
/	_____

Please return 1 copy for your confirmation with your signature and comments.

APPROVED BY	SIGNATURE DATE
S Y Park / G.Manager	_____
<b>REVIEWED BY</b>	
S J So / Manager	_____
<b>PREPARED BY</b>	
S R Yoo / Engineer	_____

**MNT Products Engineering Dept.**  
**LG Display Co., Ltd.**

**Product Specification**
Contents

No	ITEM	Page
	COVER	1
	CONTENTS	2
	RECORD OF REVISIONS	4
1	GENERAL DESCRIPTION	5
2	ABSOLUTE MAXIMUM RATINGS	6
3	ELECTRICAL SPECIFICATIONS	7
3-1	ELECTRICAL CHARACTERISTICS	7
3-2	INTERFACE CONNECTIONS	10
3-3	SIGNAL TIMING SPECIFICATIONS	12
3-4	SIGNAL TIMING WAVEFORMS	13
3-5	COLOR INPUT DATA REFERENCE	14
3-6	POWER SEQUENCE	15
4	OPTICAL SPECIFICATIONS	19
5	MECHANICAL CHARACTERISTICS	25
6	RELIABILITY	28
7	INTERNATIONAL STANDARDS	29
7-1	SAFETY	29
7-2	EMC	29
8	PACKING	30
8-1	DESIGNATION OF LOT MARK	30
8-2	PACKING FORM	30
9	PRECAUTIONS	31
9-1	MOUNTING PRECAUTIONS	31
9-2	OPERATING PRECAUTIONS	31
9-3	ELECTROSTATIC DISCHARGE CONTROL	32
9-4	PRECAUTIONS FOR STRONG LIGHT EXPOSURE	32
9-5	STORAGE	32
9-6	HANDLING PRECAUTIONS FOR PROTECTION FILM	32

**Product Specification**Contents

No	ITEM	Page
10	EDID DATA	33
10-1	EDID DATA	33
10-2	EDID READ/WRITE PROTOCOL	36



## Product Specification

**RECORD OF REVISIONS**

Revision No	Revision Date	Page	Description	
0.0	Mar. 17. 2010	-	First Draft(Preliminary)	
0.1	Apr. 13. 2010	5, 9	Update power consumption & LED Bar Electrical Characteristics	
		5,19	Update Optical Specifications - Luminance: (min) 300nit (typ)380nit → (min) 330nit (typ)420nit - Wx/Wy : 0.313/0.329 → 0.308/0.325	
1.0	Apr. 16. 2010	-	Final Draft	
		Apr. 21. 2010	7	Update Electrical Characteristics
			11	Add Sync CNT Pin Configuration
			15, 16	Update model name of power sequence (K23 → K75F)
		26	Update mechanic drawing	
		Apr. 30. 2010	26	Update mechanic drawing

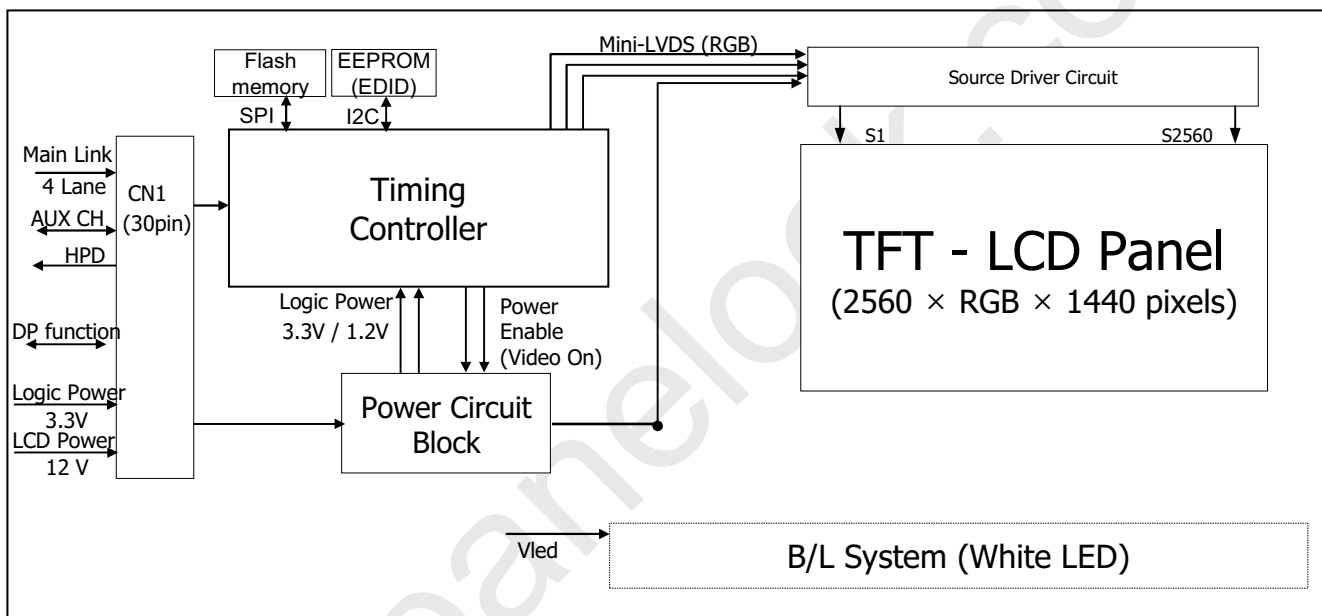
## Product Specification

### 1. General Description

LM270WQHD is a Color Active Matrix Liquid Crystal Display with Light Emitting Diode ( White LED) backlight system without LED driver. The matrix employs a-Si Thin Film Transistor as the active element. It is a transmissive type display operating in the normally black mode. It has a 27inch diagonally measured active display area with QHD resolution (2560 vertical by 1440 horizontal pixel array) Each pixel is divided into Red, Green and Blue sub-pixels or dots which are arranged in vertical stripes. Gray scale or the brightness of the sub-pixel color is determined with a 10-bit gray scale signal for each dot, thus, presenting a palette of more than 1.07B colors with FRC (Frame Rate Control).

It has been designed to apply the 10-bit 4Lane Display port interface.

It is intended to support displays where high brightness, super wide viewing angle, high color saturation, and high color are important.



### General Features

Active Screen Size	27.0 inches(68.47cm) diagonal
Outline Dimension	630.0(H) x 376.13(V) x 21.8(D) mm(Typ.)
Pixel Pitch	0.2331 mm x 0.2331 mm
Pixel Format	2560 horiz. By 1440 vert. Pixels RGB stripes arrangement
Color Depth	8-bit, 16,777,216 colors
Luminance, White	420 cd/m <sup>2</sup> ( 5 points Avg.)
Viewing Angle(CR>10)	View Angle Free (R/L 178(Typ.), U/D 178(Typ.))
Power Consumption	Total 95.51 Watt (Max.) (15.36 Watt @V <sub>LCD</sub> , Max 80.15 Watt_Duty 100% of DC 350 mA_w/o driver)
Weight	4600 g (typ.)
Display Operating Mode	Transmissive mode, normally black
Surface Treatment	Glare (Low Reflection treatment of the front polarizer)
HDCP	HDCP key implemented in Tcon (DP628)

## Product Specification

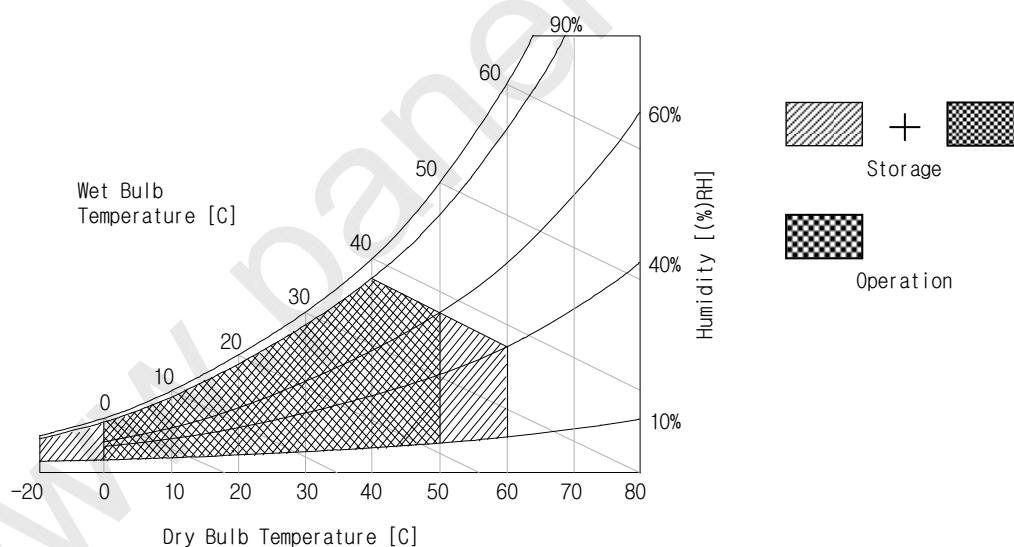
### 2. Absolute Maximum Ratings

The following are maximum values which, if exceeded, may cause faulty operation or damage to the unit.

**Table 1. ABSOLUTE MAXIMUM RATINGS**

Parameter	Symbol	Values		Units	Notes
		Min	Max		
Power Input Voltage	VLCD	-0.3	14	Vdc	at 25 ± 2°C
Power Input Voltage	VDPLGIC	-0.5	4	Vdc	at 25 ± 2°C
Operating Temperature	TOP	0	50	°C	1
Storage Temperature	TST	-20	60	°C	
Operating Ambient Humidity	HOP	10	90	%RH	
Storage Humidity	HST	10	90	%RH	

Note : 1. Temperature and relative humidity range are shown in the figure below.  
 Wet bulb temperature should be 39 °C Max, and no condensation of water.




**LM270WQ1**  
**Liquid Crystal Display**
**Product Specification**
**3. Electrical Specifications**
**3-1. Electrical Characteristics**

It requires two power inputs. One is employed to power the LCD electronics and to drive the TFT array and liquid crystal. The second input power for the DP Rx.

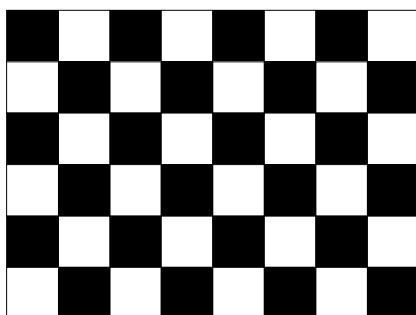
**Table 2-1-1. ELECTRICAL CHARACTERISTICS (Normal Mode)**

Parameter	Symbol	Values			Unit	Notes
		Min	Typ	Max		
MODULE :						
Power Supply Input voltage	VLCD	11.4	12.0	12.6	Vdc	
Permissive Power Input Ripple	VRF_VLCD	-	-	400	mVp-p	
Power Supply Input Current	ILCD	-	890	1025	mA	1
		-	1280	1475	mA	2
Power Consumption	PLCD	-	10.68	12.30	Watt	1
		-	15.36	17.70	Watt	2
Rush Current	IRUSH_VLCD	-	-	3.0	A	3
DP Logic Input Voltage	VCC_L_IN	3.13	3.3	3.47	Vdc	
Permissive Logic Input Ripple	VRF_VCC_L_IN	-	-	100	mVp-p	
DP Logic Input Current	I_VCC_L_IN		300		mA	1
			300		mA	2
DP Logic Power Consumption	P_VCC_L_IN		1.0		Watt	
DP Rush Current	IRUSH_VCC_L_IN	-	-	1.0	A	3

**Product Specification****Note :**

1. The specified current and power consumption are under the  $V_{LCD}=12.0V$ ,  $25 \pm 2^{\circ}C$ ,  $f_V=60Hz$  condition whereas mosaic pattern(8 x 6) is displayed and  $f_V$  is the frame frequency.
2. The current is specified at the maximum current pattern.
3. The duration of rush current is about 2ms and rising time of power Input is 1ms(min.).

White : 255Gray  
Black : 0Gray



Mosaic Pattern(8 x 6)

Maximum current pattern



White Pattern



**Product Specification**
**Table 2-2. LED Bar ELECTRICAL CHARACTERISTICS**

Items	Symbol	Spec			Unit	Remark	Notes
		Min	Typ	Max			
LED String Voltage	$V_S$	31	36	41	Vrms	Ta=25℃, at DC 350 mA	2,7
LED Bar Voltage	$V_{Bar}$	-	216	229	Vrms	Ta=25℃, at DC 350 mA	3,7
LED String Power	$P_S$	10.85	12.6	14.35	W	Ta=25℃, at DC 350 mA	3,6,7
LED Bar Power	$P_L$	-	75.6	80.15	W	Ta=25℃, at DC 350 mA	4,6,7
BL Power	$P_{BL}$	-	75.6	80.15	W	Ta=25℃, at Duty 100% of DC 350 mA	6,7
LED Life Time	LED_LT	(39,000)		-	Hrs	Ta=25℃, at Duty 100% of DC 350 mA	5,7
LED Junction Temperature	$T_j$			150	℃	-	7

**LED driver design guide**

: The design of the LED driver must have specifications for the LED in LCD Assembly.

The performance of the LED in LCM, for example life time or brightness, is extremely influenced by the characteristics of the LED driver.

So all the parameters of an LED driver should be carefully designed and output current should be Constant current control.

Please control feedback current of each string individually to compensate the current variation among the strings of LEDs.

When you design or order the LED driver, please make sure unwanted lighting caused by the mismatch of the LED and the LED driver (no lighting, flicker, etc) never occurs.

When you confirm it, the LCD module should be operated in the same condition as installed in your instrument.

- Specified values are for a single LED bar including Left & Right Bar.
- The specified current is input LED chip 100% duty current.
- The specified voltage is input LED string and Bar voltage at typical 350 mA 100% duty current.
- The specified power consumption is input LED bar power consumption at typical 350 mA 100% duty current.
- The life is determined as the time at which luminance of the LED is 50% compared to that of initial value at the typical LED current on condition of continuous operating at  $25 \pm 2^\circ\text{C}$ .
- The LED power consumption shown above does not include loss of external driver.  
The used LED BL current is the LED typical current.  
String Power Consumption is calculated with  $P_S = V_S \times 350\text{mA}$   
Bar Power Consumption is calculated with  $P_L = V_{Bar} \times 350\text{mA}$   
BL Power Consumption is calculated with  $P_{BL} = V_{Bar} \times 350\text{mA}$
- LED operating DC Forward Current and Junction Temperature must not exceed LED Max Ratings.

## Product Specification

### 3-2. Interface Connections

#### 3-2-1. LCD Module

- LCD Connector(CN1). : FI-X30SSL-HF (manufactured by JAE)  
The pin configuration for the 30 pin connector is shown in the table below.

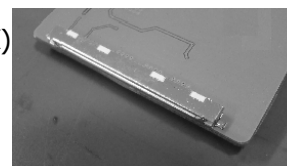
**Table 3 MODULE CONNECTOR(CN\_SIG) PIN CONFIGURATION**

Pin No.	Symbol	Description	Pin No.	Symbol	Description
1	DDC_SCL	DDC for Clock	16	Lane3P	True Signal for Main Link 3
2	DDC_SDA	DDC for Data	17	Lane3N	Component Signal for Main Link 3
3	GND	High Speed Ground for Auxiliary Channel	18	GND	High Speed Ground
4	AUX_CH N	Component Signal for Auxiliary Channel	19	SPDIF	Audio output from DP RX
5	AUX_CH P	True Signal for Auxiliary Channel	20	VIDEO_ON	Video status from DP RX
6	GND	High Speed Ground for Main Link 0	21	HPD	Hot Plug Detect Signal
7	Lane0P	True Signal for Main Link 0	22	GND	GND for main power
8	Lane0N	Component Signal for Main Link 0	23	GND	GND for main power
9	GND	High Speed Ground for Main Link 1	24	GND	GND for main power
10	Lane1P	True Signal for Main Link 1	25	GND	GND for main power
11	Lane1N	Component Signal for Main Link 1	26	VLCD	12V for LCM main power
12	GND	High Speed Ground for Main Link 2	27	VLCD	12V for LCM main power
13	Lane2P	True Signal for Main Link 2	28	VLCD	12V for LCM main power
14	Lane2N	Component Signal for Main Link 2	29	VLCD	12V for LCM main power
15	GND	High Speed Ground for Main Link 3	30	VCC_L_IN	3.3V for DP TCON power

Notes : 1. Connector

2.1 Connector(Receptacle) : FI-X30SSL-HF(JAE) or 20389-Y30E-01(I-PEX)

2.2 Mating Connector(Plug) : FI-X30HL(JAE) or 20385-Y30T-12F(I-PEX)



**Product Specification**
**3-2-2. Backlight Interface**

- LED Connector : **H401K-D12N-12B** (Manufactured by E&T)
- Mating Connector : **4530K-F12N-01R** (Manufactured by E&T)

**Table 5. LED CONNECTOR PIN CONFIGURATION**

Pin No.	Symbol	Description	Note
1	L_LED1+	LED channel 1 Anode	Left bar
2	L_LED1-	LED channel 1 Cathode	
3	L_LED2+	LED channel 2 Anode	
4	L_LED2-	LED channel 2 Cathode	
5	L_LED3+	LED channel 3 Anode	
6	L_LED3-	LED channel 3 Cathode	
7	R_LED1+	LED channel 1 Anode	Right bar
8	R_LED1-	LED channel 1 Cathode	
9	R_LED2+	LED channel 2 Anode	
10	R_LED2-	LED channel 2 Cathode	
11	R_LED3+	LED channel 3 Anode	
12	R_LED3-	LED channel 3 Cathode	

**3-2-3. Sync Connector**

This connector is used for synchronized LED Driver.  
 The connector is 53780-8604. (Manufactured by MOLEX)

**Table 5. LED SYNCHRONIZED CONNECTOR(CN4) PIN CONFIGURATION**

Pin	Symbol	Description	NOTES
1	GND	Ground	
2	ENBLT	Enable	
3	PWM	PWM for synchronized LED Driver	1
4	I_RES	GSP for synchronized LED Driver	2

Note: 1. PWM signal follows multiplied Horizontal frequency and level is 3.3V TTL level.  
 2. GSP frequency follows refresh time and level is 3.3V TTL level  
 and high width is 1/(Horizontal freq).

**Product Specification**
**3-3. Signal Timing Specifications**

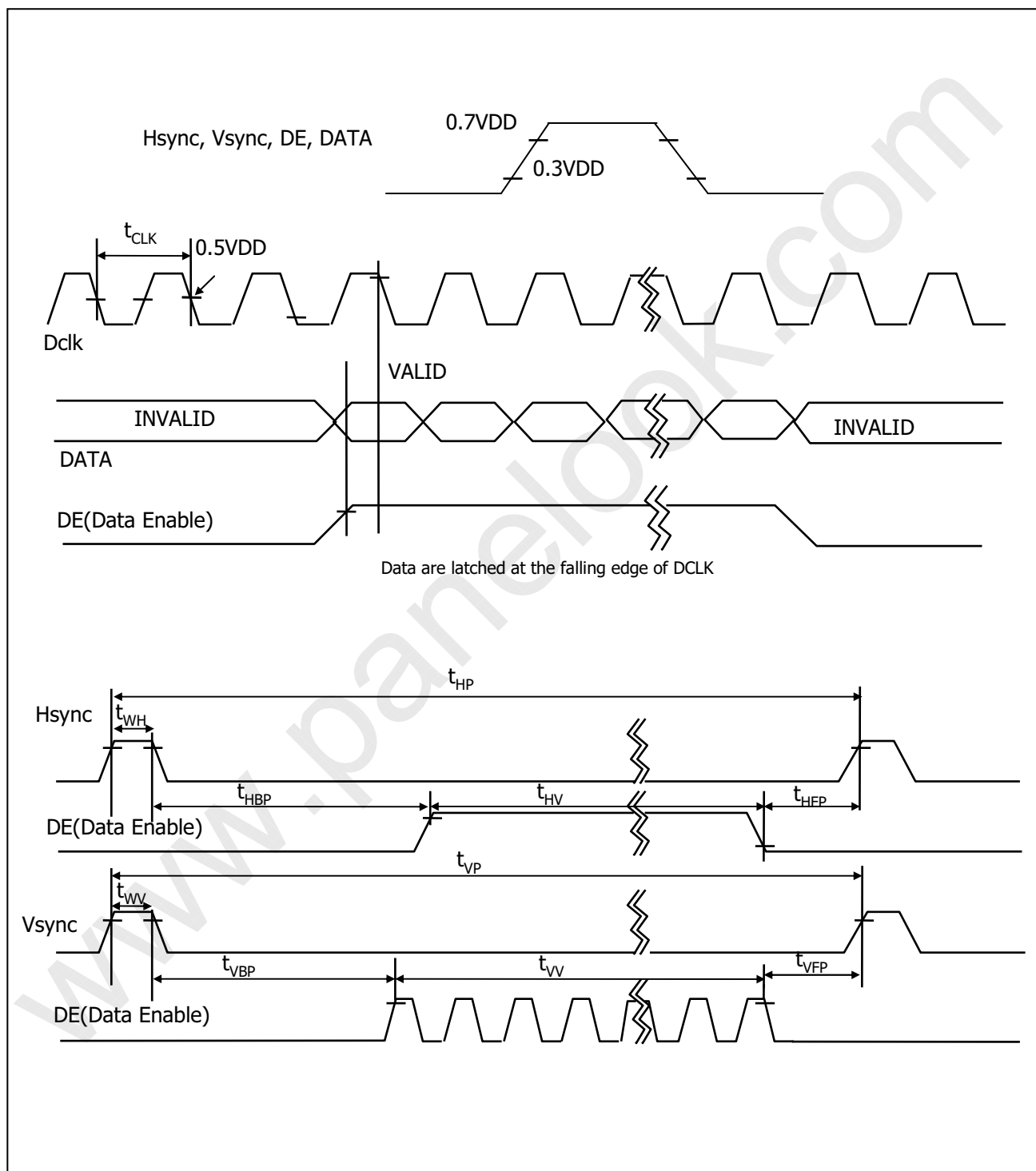
All of the interface signal timing should be satisfied with the following specifications for it's proper operation.

**Table 6. TIMING TABLE (VESA COORDINATED VIDEO TIMING)**

ITEM		SYMBOL	Min	Typ	Max	Unit	Note
DCLK	Period	tCLK	4.14	4.14	4.14	ns	
	Frequency	fCLK	241.5	241.5	241.5	MHz	-
Hsync	Period	tHP	2720	2720	2720	tCLK	
	Width-Active	tWH	32	32	32		
Vsync	Period	tVP	1481	1481	1481	tHP	
	Frequency	fV	59.95	59.95	59.95	Hz	
	Width-Active	tWV	5	5	5	tHP	
Data Enable	Horizontal Valid	tHV	2560	2560	2560	tCLK	
	Horizontal Back Porch	tHBP	80	80	80		
	Horizontal Front Porch	tHFP	48	48	48		
	Horizontal Blank	-	160	160	160		tWH+ tHBP+ tHFP
	Vertical Valid	tVV	1440	1440	1440	tHP	
	Vertical Back Porch	tVBP	33	33	33		
	Vertical Front Porch	tVFP	3	3	3		
	Vertical Blank	-	41	41	41		tWV+ tVBP+ tVFP

Note: Hsync period and Hsync width-active should be even number times of tCLK. If the value is odd number times of tCLK, display control signal can be asynchronous. In order to operate this LCM a Hsync, Vsync, and DE(data enable) signals should be used.

1. The performance of the electro-optical characteristics may be influenced by variance of the vertical refresh rates.
2. Vsync and Hsync should be keep the above specification.
3. Hsync Period, Hsync Width, and Horizontal Back Porch should be any times of of character number(8).
4. The polarity of Hsync, Vsync is not restricted.

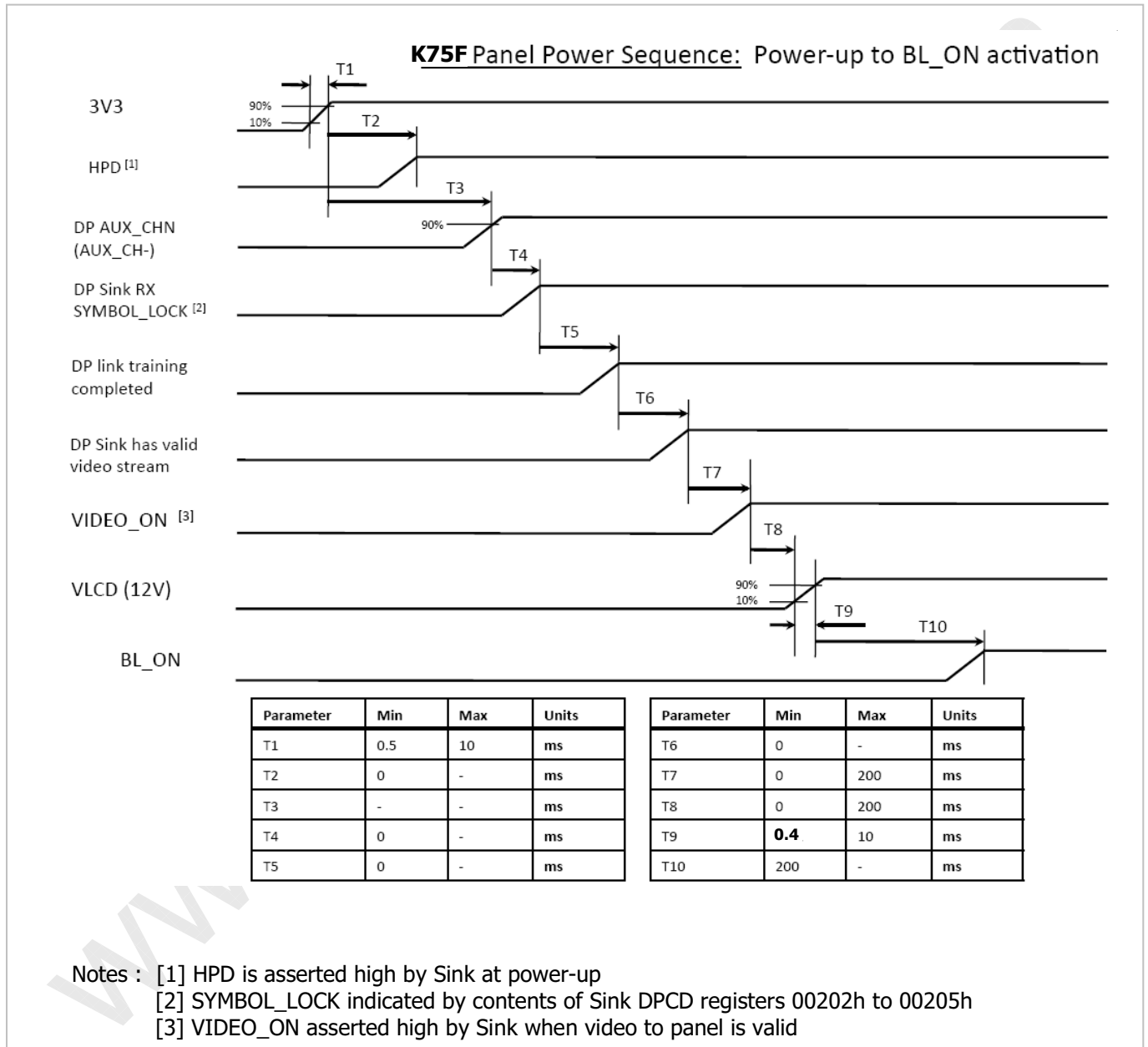
**Product Specification**
**3-4. Signal Timing Waveforms**


**Product Specification**
**3-5. Color Data Reference**

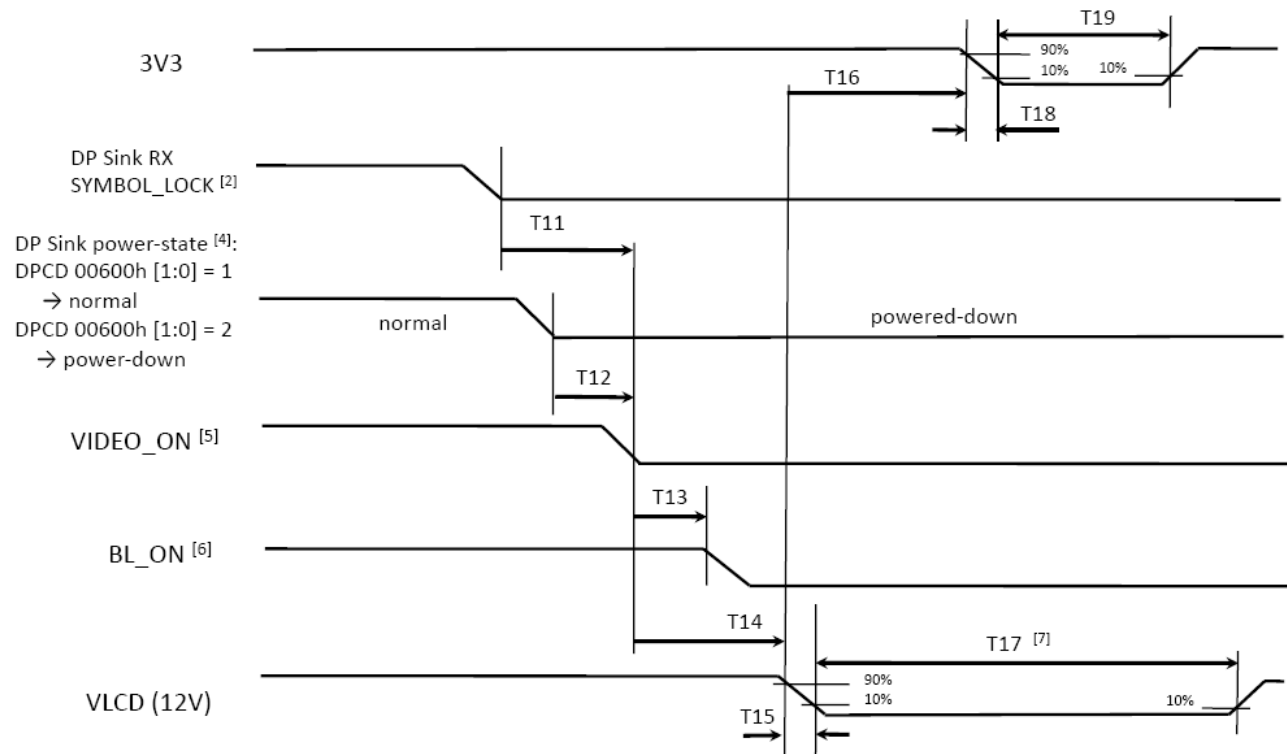
The Brightness of each primary color(red,green,blue) is based on the 8-bit gray scale data input for the color; the higher the binary input, the brighter the color. The table below provides a reference for color versus data input.

**Table 7. COLOR DATA REFERENCE**

Color		Input Color Data																							
		RED								GREEN								BLUE							
		MSB				LSB				MSB				LSB				MSB				LSB			
		R7	R6	R5	R4	R3	R2	R1	R0	G7	G6	G5	G4	G3	G2	G1	G0	B7	B6	B5	B4	B3	B2	B1	B0
Basic Color	Black	0	0	0	0	0	0	0	0	0	0	0	0	0	0	0	0	0	0	0	0	0	0	0	0
	Red (255)	1	1	1	1	1	1	1	1	0	0	0	0	0	0	0	0	0	0	0	0	0	0	0	0
	Green (255)	0	0	0	0	0	0	0	0	1	1	1	1	1	1	1	1	0	0	0	0	0	0	0	0
	Blue (255)	0	0	0	0	0	0	0	0	0	0	0	0	0	0	0	0	1	1	1	1	1	1	1	1
	Cyan	0	0	0	0	0	0	0	0	1	1	1	1	1	1	1	1	1	1	1	1	1	1	1	1
	Magenta	1	1	1	1	1	1	1	1	0	0	0	0	0	0	0	0	1	1	1	1	1	1	1	1
	Yellow	1	1	1	1	1	1	1	1	1	1	1	1	1	1	1	1	0	0	0	0	0	0	0	0
	White	1	1	1	1	1	1	1	1	1	1	1	1	1	1	1	1	1	1	1	1	1	1	1	1
RED	RED (000) Dark	0	0	0	0	0	0	0	0	0	0	0	0	0	0	0	0	0	0	0	0	0	0	0	0
	RED (001)	0	0	0	0	0	0	0	1	0	0	0	0	0	0	0	0	0	0	0	0	0	0	0	0
	...	...								...								...							
	RED (254)	1	1	1	1	1	1	1	0	0	0	0	0	0	0	0	0	0	0	0	0	0	0	0	0
	RED (255)	1	1	1	1	1	1	1	1	0	0	0	0	0	0	0	0	0	0	0	0	0	0	0	0
GREEN	GREEN (000) Dark	0	0	0	0	0	0	0	0	0	0	0	0	0	0	0	0	0	0	0	0	0	0	0	0
	GREEN (001)	0	0	0	0	0	0	0	0	0	0	0	0	0	0	0	1	0	0	0	0	0	0	0	0
	...	...								...								...							
	GREEN (254)	0	0	0	0	0	0	0	0	1	1	1	1	1	1	1	0	0	0	0	0	0	0	0	0
	GREEN (255)	0	0	0	0	0	0	0	0	1	1	1	1	1	1	1	1	0	0	0	0	0	0	0	0
BLUE	BLUE (000) Dark	0	0	0	0	0	0	0	0	0	0	0	0	0	0	0	0	0	0	0	0	0	0	0	0
	BLUE (001)	0	0	0	0	0	0	0	0	0	0	0	0	0	0	0	0	0	0	0	0	0	0	0	1
	...	...								...								...							
	BLUE (254)	0	0	0	0	0	0	0	0	0	0	0	0	0	0	0	0	1	1	1	1	1	1	1	0
	BLUE (255)	0	0	0	0	0	0	0	0	0	0	0	0	0	0	0	0	1	1	1	1	1	1	1	1

**Product Specification**
**3-6. Power Sequence**
**3-6-1. Power Sequence**


- Notes :
1. Please avoid floating state of interface signal at invalid period.
  2. When the interface signal is invalid, be sure to pull down the power supply for LCD  $V_{LCD}$  to 0V.
  3. LED power must be turn on after power supply for LCD and interface signal are valid.

**Product Specification**
**3-6. Power Sequence**
**3-6-1. Power Sequence**
**K75F Panel Power Sequence: BL\_ON de-activation**


Parameter	Min	Max	Units
T11	0	10	ms
T12	0	5	ms
T13	-	10	ms
T14	10	100	ms
T15	0.01	1000	ms

Parameter	Min	Max	Units
T16	0	-	ms
T17	250	-	ms
T18	0.01	1000	ms
T19	150	-	ms

Notes : [2] SYMBOL\_LOCK indicated by contents of Sink DPCD registers 00202h to 00205h

[4] Power-state set by Source in Sink DPCD register 00600h

[5] VIDEO\_ON asserted low by Sink because of :

- 1) loss of SYMBOL\_LOCK or
- 2) DP Sink is powered down

[6] BL\_ON must be asserted low by system as rapidly as possible when video is invalid to avoid visible artifacts

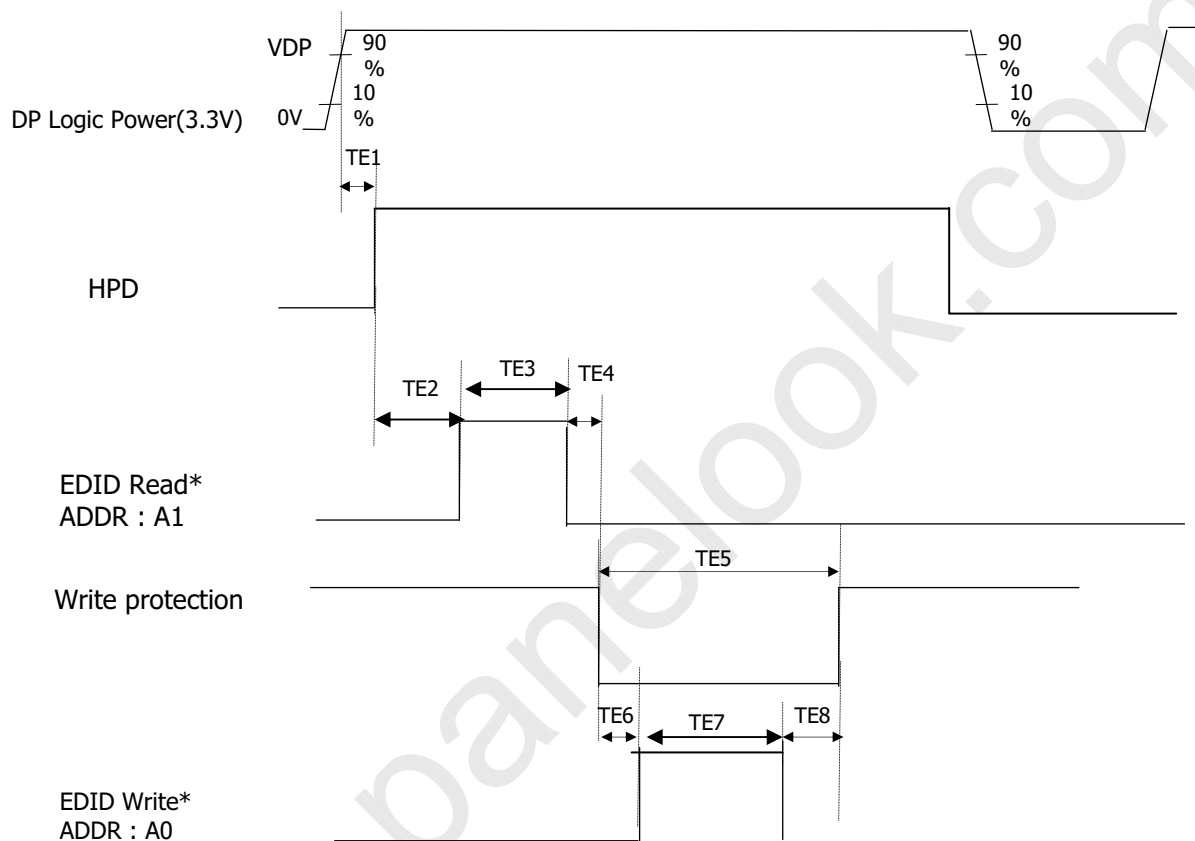
[7] T17 always > T19

[8] min. times of 0 indicate precedence ordering of events, e.g. where actual timing is TBD



**Product Specification**
**3-6-2. Power Sequence, EDID Read / Write**

\*\*\* This timing is for fabrication purpose only, not for normal operation. \*\*\*



\* EDID Read time and EDID write time will be exclusive.

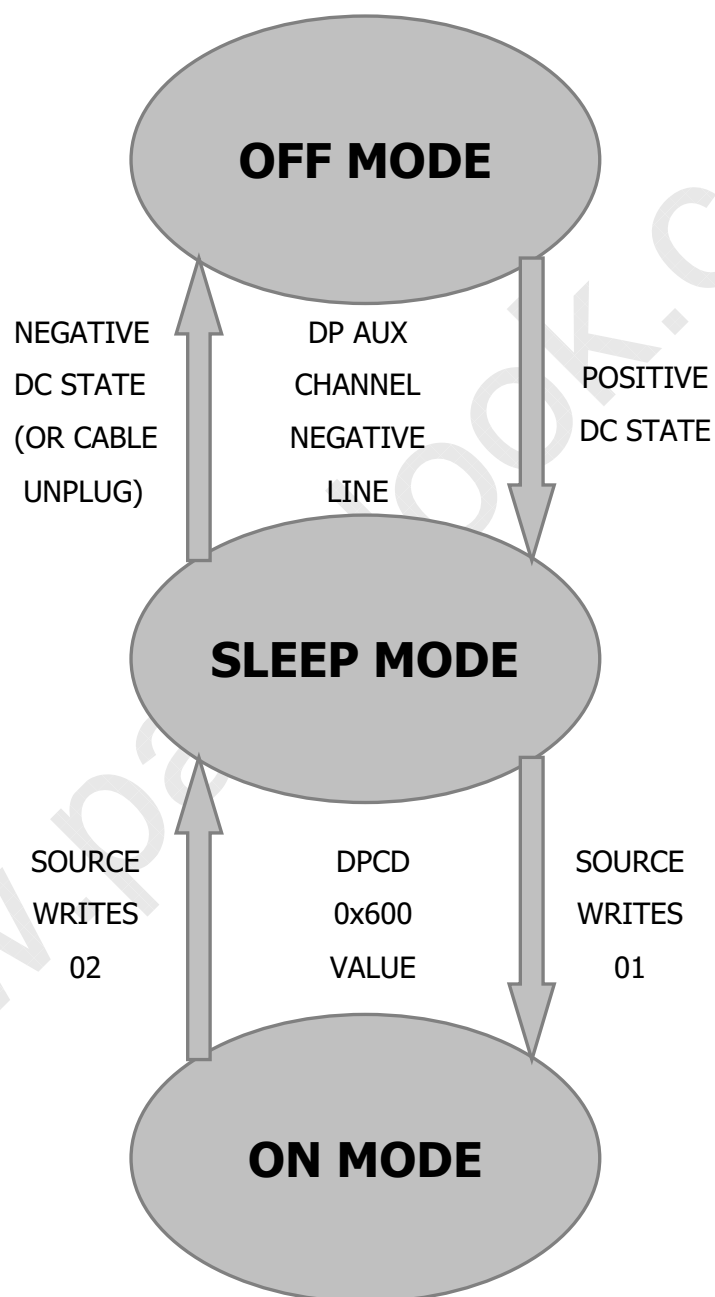
**Notes.**

In case of without DP signal after DP logic power on, check HPD after TE1 time and if HPD is low status then any time can read EDID

**Table 8.1 POWER SEQUENCE, EDID**

Parameter	Values			Units
	Min	Typ	Max	
TE1	-	30	50	ms
TE2	1000	-	-	ms
TE3	-	20	-	ms
TE4	1	-	-	ms
TE5	-	-	2000	ms
TE6	1	-	-	ms
TE7	-	20	-	ms
TE8	1	-	-	ms

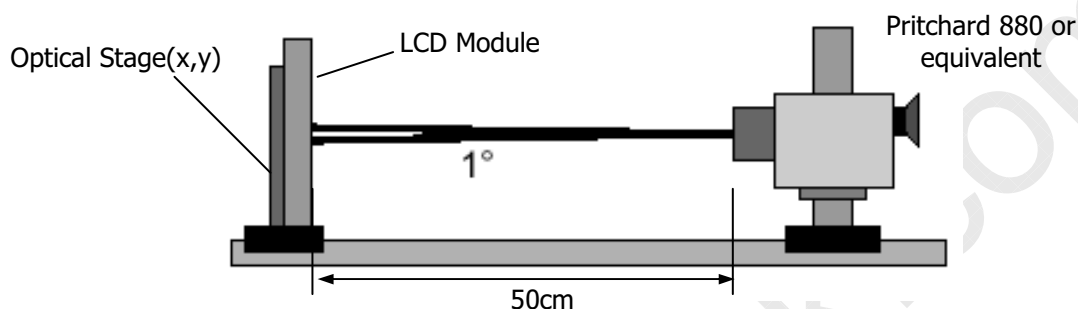
## 3-6-3. State Machine



**Product Specification**
**4. Optical Specifications**

Optical characteristics are determined after the unit has been 'ON' for approximately 70 minutes in a dark environment at  $25 \pm 2^\circ\text{C}$ . The values specified are at an approximate distance 50cm from the LCD surface at a viewing angle of  $\Phi$  and  $\theta$  equal to  $0^\circ$  and aperture 1 degree.

FIG. 1 presents additional information concerning the measurement equipment and method.


**FIG. 1 Optical Characteristic Measurement Equipment and Method**
**Table 9. OPTICAL CHARACTERISTICS**
 $(T_a = 25^\circ\text{C}, V_{\text{LCD}} = 12.0\text{V}, f_v = 60\text{Hz}, \text{Dclk} = 242.28\text{MHz})$ 

Parameter	Symbol	Values			Units	Notes	
		Min	Typ	Max			
Contrast Ratio	CR	700	1000	-		1	
Surface Luminance, white	$L_{\text{WH}}$	330	420	-	$\text{cd}/\text{m}^2$	2	
Luminance Variation	$\delta_{\text{WHITE}}$			30	%	3	
Response Time	Rise Time	$T_{\text{R}}$	-	6.5	14	ms	4.1
	Decay Time	$T_{\text{D}}$	-	7.5	14	ms	4.1
Color Coordinates [CIE1931]	RED	$R_x$	Typ -0.03	0.652	Typ +0.03		
		$R_y$		0.334			
	GREEN	$G_x$		0.304			
		$G_y$		0.619			
	BLUE	$B_x$		0.148			
		$B_y$		0.049			
	WHITE	$W_x$		0.308			
	$W_y$	0.325					
Color Shift	Horizontal	$\theta_{\text{CST}_H}$	-	178	-	Degree	5
	Vertical	$\theta_{\text{CST}_V}$	-	178	-		
Viewing Angle (CR>10)							
General	Horizontal	$\theta_H$	170	178	-	Degree	6
	Vertical	$\theta_V$	170	178	-		
Effective	Horizontal	$\theta_{\text{GMA}_H}$		178	-	Degree	7
	Vertical	$\theta_{\text{GMA}_V}$		178	-		
Gray Scale				2.2			8

## Product Specification

Notes 1. Contrast Ratio(CR) is defined mathematically as :

$$\text{Contrast Ratio} = \frac{\text{Surface Luminance with all white pixels}}{\text{Surface Luminance with all black pixels}}$$

It is measured at center point(Location P1)

2. Surface luminance( $L_{WH}$ ) is luminance value at 5 points average across the LCD surface 50cm from the surface with all pixels displaying white. For more information see FIG 2.

$$L_{WH} = \text{Average}[L_{on1}, L_{on2}, L_{on3}, L_{on4}, L_{on5}]$$

3. The variation in surface luminance,  $\delta_{WHITE}$  is defined as :

$$\delta_{WHITE} = \frac{\text{Maximum}(L_{on1}, L_{on2}, \dots, L_{on13}) - \text{Minimum}(L_{on1}, L_{on2}, \dots, L_{on13})}{\text{Average}(L_{on1}, L_{on2}, \dots, L_{on5})} \times 100(\%)$$

Where L1 to L13 are the luminance with all pixels displaying white at 13 locations.

For more information see FIG 2.

4. Response time is the time required for the display to transition from black to white (Rise Time,  $Tr_R$ ) and from white to black (Decay Time,  $Tr_D$ ). For additional information see FIG 3

5. Color shift is the angle at which the color difference is lower than 0.04.

For more information see FIG 4.

- Color difference ( $\Delta u'v'$ )

$$u' = \frac{4x}{-2x + 12y + 3} \quad v' = \frac{9y}{-2x + 12y + 3}$$

$$\Delta u'v' = \sqrt{(u'_1 - u'_2)^2 + (v'_1 - v'_2)^2} \quad \begin{array}{l} u'_1, v'_1 : u'v' \text{ value at viewing angle direction} \\ u'_2, v'_2 : u'v' \text{ value at front } (\theta=0) \end{array}$$

- Pattern size : 25% Box size

- Viewing angle direction of color shift : Horizontal, Vertical

6. Viewing angle is the angle at which the contrast ratio is greater than 10. The angles are determined for the horizontal or x axis and the vertical or y axis with respect to the z axis which is normal to the LCD surface. For more information see FIG 5.

7. Effective viewing angle is the angle at which the gamma shift of gray scale is lower than 0.3.

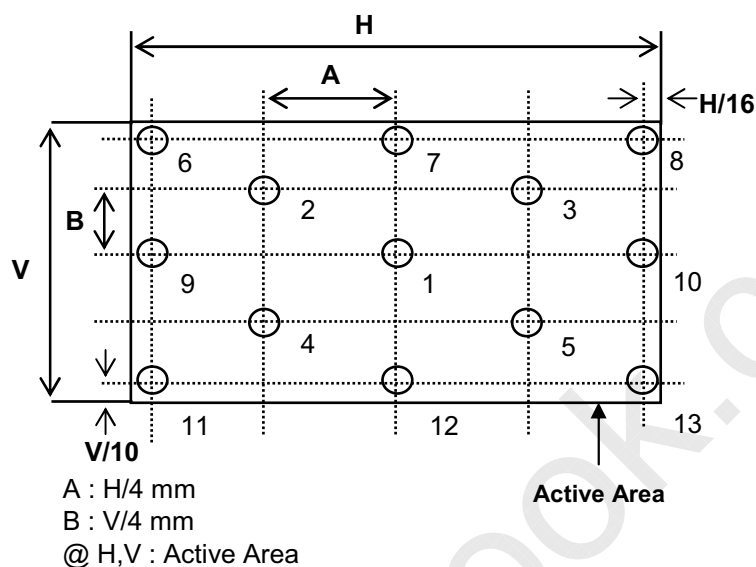
For more information see FIG 6 and FIG 7.

8. Gray scale specification

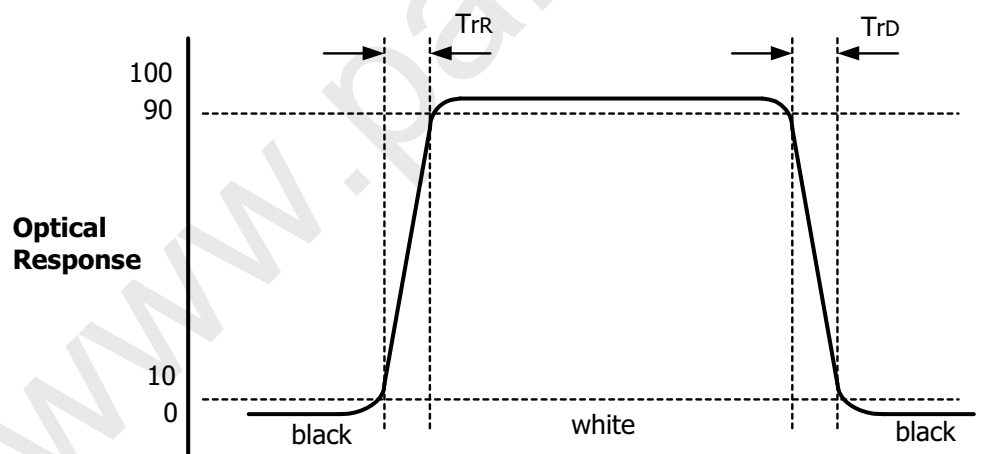
Gamma Value is approximately 2.2. For more information see Table 10.

**Product Specification**

Measuring point for surface luminance & measuring point for luminance variation.

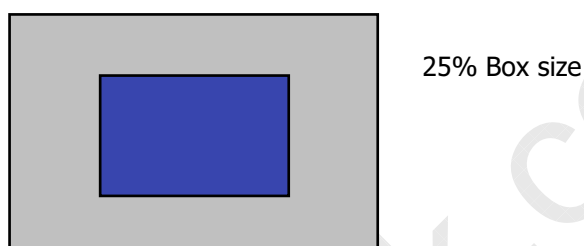

**FIG. 2 Measure Point for Luminance**

The response time is defined as the following figure and shall be measured by switching the input signal for "black" and "white".


**FIG. 3. Response Time**

**Product Specification**

Color shift is defined as the following test pattern and color.


**FIG. 4 Test Pattern**

Average RGB values in Bruce RGB for Macbeth Chart

	Dark skin	Light skin	Blue sky	Foliage	Blue flower	Bluish green
R	98	206	85	77	129	114
G	56	142	112	102	118	199
B	45	123	161	46	185	178
	Orange	Purplish blue	Moderate red	Purple	Yellow green	Orange yellow
R	219	56	211	76	160	230
G	104	69	67	39	193	162
B	24	174	87	86	58	29
	Blue	Green	Red	Yellow	Magenta	cyan
R	26	72	197	241	207	35
G	32	148	27	212	62	126
B	145	65	37	36	151	172
	White	Neutral 8	Neutral 6.5	Neutral 5	Neutral 3.5	black
R	240	206	155	110	63	22
G	240	206	155	110	63	22
B	240	206	155	110	63	22

Product Specification

Dimension of viewing angle range.

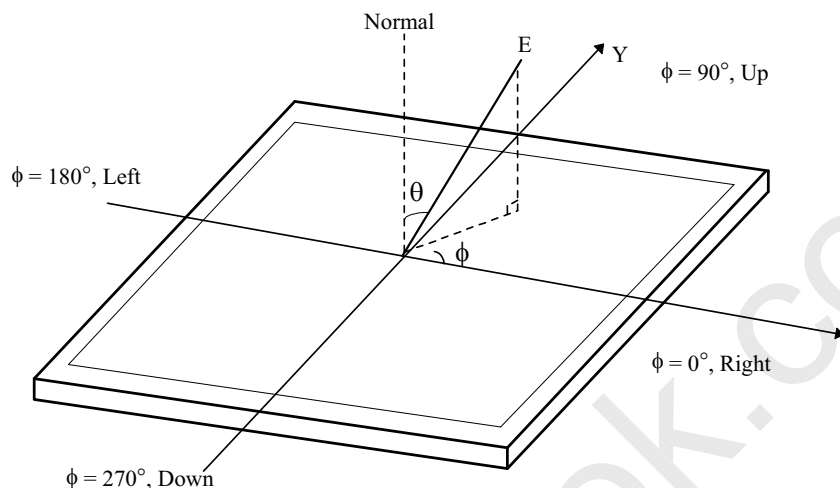


FIG. 5 Viewing angle

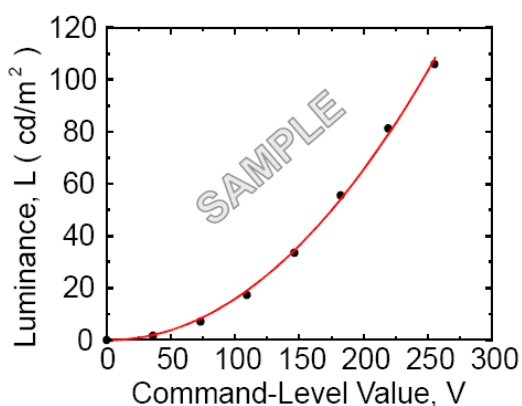


FIG. 6 Sample Luminance vs. gray scale (using a 256 bit gray scale)

$$L = aV^r + L_b$$

Here the Parameter  $a$  and  $\gamma$  relate the signal level  $V$  to the luminance  $L$ .  
The GAMMA we calculate from the log-log representation (FIG. 7)

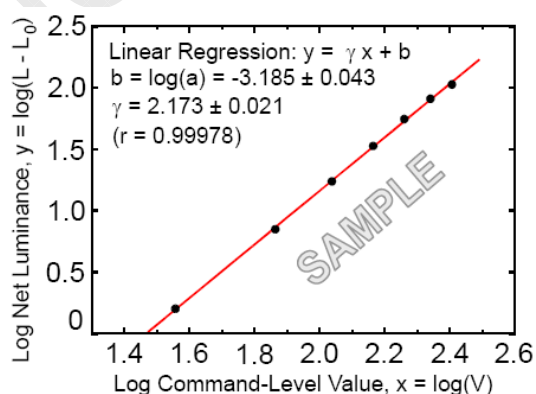


FIG. 7 Sample Log-log plot of luminance vs. gray scale

$$\log(L - L_b) = r \log(V) + \log(a)$$

## Product Specification

**Table 10. Gray Scale Specification**

Gray Level	Relative Luminance [%] (Typ.)
0	0.10
31	1.08
63	4.71
95	11.5
127	21.7
159	35.5
191	53.1
223	74.5
255	100



**Product Specification**
**5. Mechanical Characteristics**

The contents provide general mechanical characteristics. In addition the figures in the next page are detailed mechanical drawing of the LCD.

Outline Dimension	Horizontal	630.0mm
	Vertical	376.13mm
	Depth	21.8mm
Bezel Area	Horizontal	601.7mm
	Vertical	340.7mm
Active Display Area	Horizontal	596.74mm
	Vertical	335.66mm
Weight	4,600g (Typ.)	
Surface Treatment	Hard coating(2H) Glare, Low Reflection treatment of the front polarizer	

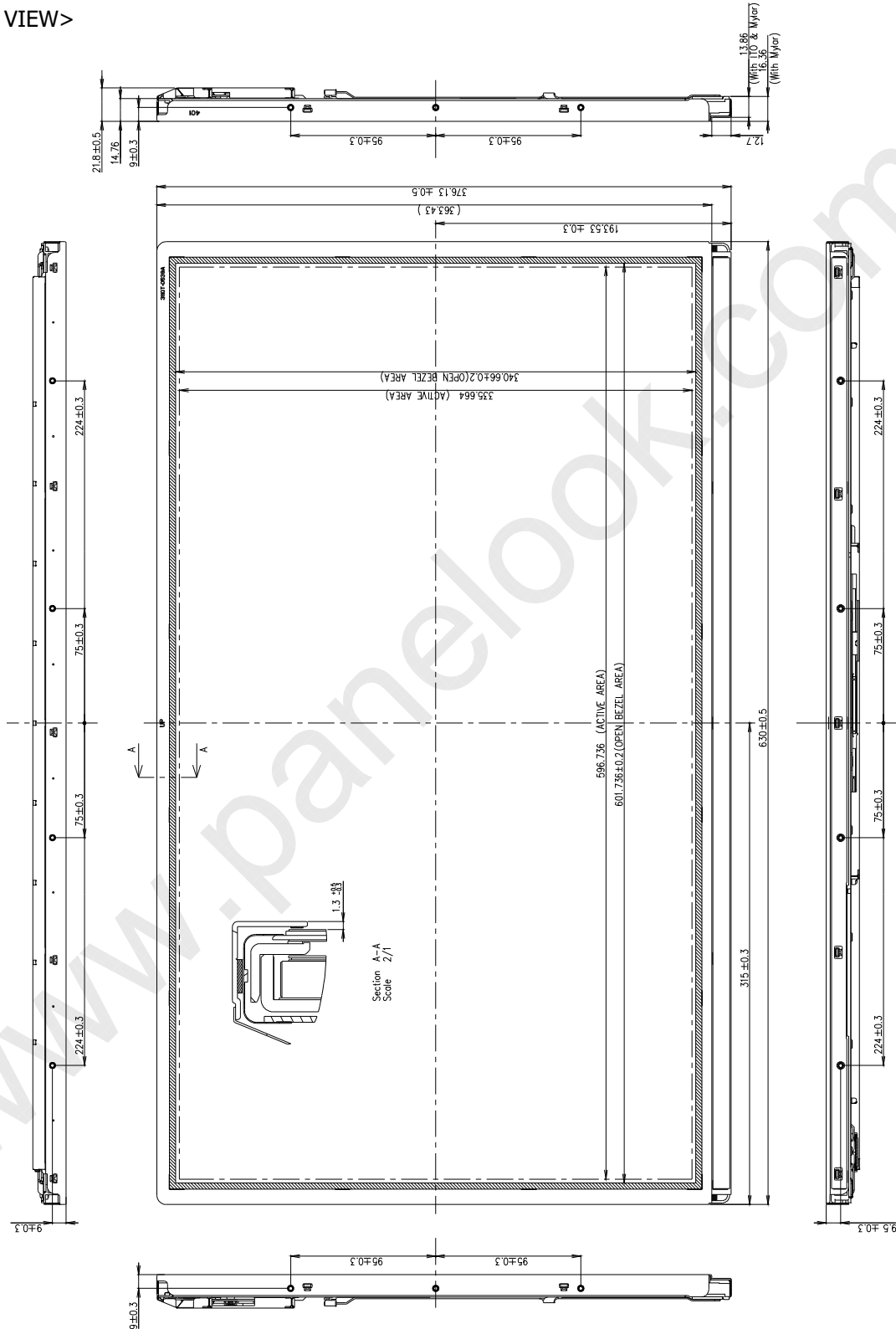
Notes : Please refer to a mechanic drawing in terms of tolerance at the next page.



**LM270WQ1**  
Liquid Crystal Display

Product Specification

<FRONT VIEW>



Ver. 1.0

APR. 30. 2010

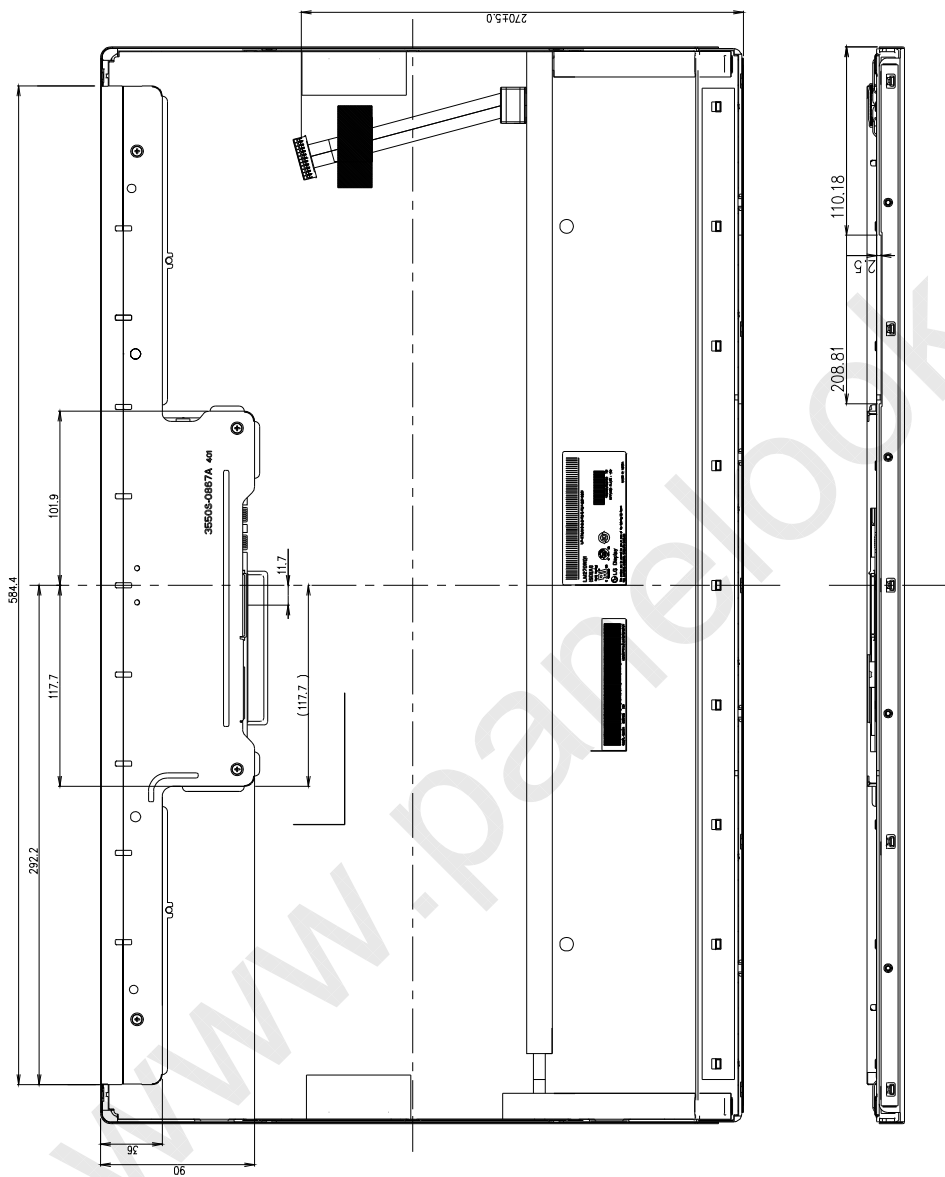
26 / 36



**LM270WQ1**  
**Liquid Crystal Display**

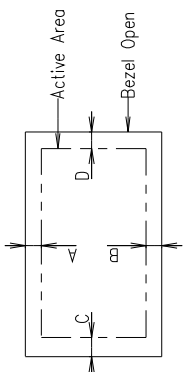
**Product Specification**

<REAR VIEW>



- Notes
1. Unspecified tolerances are to be  $\pm 0.5\text{mm}$ .
  2. Tilt and partial disposition tolerance of display area are as following.

- (1) Y-direction :  $|A-B| \leq 1.4\text{mm}$
- (2) X-direction :  $|C-D| \leq 1.4\text{mm}$



3. Torque SPEC of Mounting :  $6.0 \sim 7.0\text{kgf cm}$  M3.0 Machine Screw(0.5 Pitch)
4. I/F Connector Specification : 20389-Y30E-01 (manufactured by I-PEX) or Compatible.
5. LED Connector Specification : H401K-D06N-12B (Manufactured by E&T) or Compatible

**Product Specification**
**6. Reliability**

Environment test condition

No	Test Item	Condition
1	High temperature storage test	Ta= 60°C 240h
2	Low temperature storage test	Ta= -20°C 240h
3	High temperature operation test	Ta= 50°C 50%RH 240h
4	Low temperature operation test	Ta= 0°C 240h
5	Vibration test (non-operating)	Wave form : random Vibration level : 1.0G RMS Bandwidth : 10-300Hz Duration : X,Y,Z, 10 min One time each direction
6	Shock test (non-operating)	Shock level : 100Grms Waveform : half sine wave, 2ms Direction : ± X, ± Y, ± Z One time each direction
7	Altitude Operating Storage / Shipment	0 - 10,000 feet(3,048m) 0 - 40,000 feet(12,192m)

**Product Specification****7. International Standards****7-1. Safety**

- a) UL 60950-1:2003, First Edition, Underwriters Laboratories, Inc., Standard for Safety of Information Technology Equipment.
- b) CAN/CSA C22.2, No. 60950-1-03 1st Ed. April 1, 2003, Canadian Standards Association, Standard for Safety of Information Technology Equipment.
- c) EN 60950-1:2001, First Edition, European Committee for Electrotechnical Standardization(CENELEC) European Standard for Safety of Information Technology Equipment.
- d) IEC 60950-1:2001, First Edition, The International Electrotechnical Commission (IEC) Standard for Safety of Information Technology Equipment. (Including report of IEC60825-1 Ed. 1.22001, clause 8 and clause 9)

**7-2. EMC**

- a) ANSI C63.4 "Methods of Measurement of Radio-Noise Emissions from Low-Voltage Electrical and Electrical Equipment in the Range of 9kHz to 40GHz." American National Standards Institute(ANSI), 1992
- b) C.I.S.P.R "Limits and Methods of Measurement of Radio Interface Characteristics of Information Technology Equipment." International Special Committee on Radio Interference.
- c) EN 55022 "Limits and Methods of Measurement of Radio Interface Characteristics of Information Technology Equipment." European Committee for Electrotechnical Standardization.(CENELEC), 1998 ( Including A1: 2000 )

**Product Specification**
**8. Packing**
**8-1. Designation of Lot Mark**

## a) Lot Mark

A	B	C	D	E	F	G	H	I	J	K	L	M
---	---	---	---	---	---	---	---	---	---	---	---	---

A,B,C : SIZE(INCH)  
 E : MONTH

D : YEAR  
 F ~ M : SERIAL NO.

## Note

## 1. YEAR

Year	2001	2002	2003	2004	2005	2006	2007	2008	2009	2010
Mark	1	2	3	4	5	6	7	8	9	0

## 2. MONTH

Month	Jan	Feb	Mar	Apr	May	Jun	Jul	Aug	Sep	Oct	Nov	Dec
Mark	1	2	3	4	5	6	7	8	9	A	B	C

## b) Location of Lot Mark

Serial No. is printed on the label. The label is attached to the backside of the LCD module.  
 This is subject to change without prior notice.

**8-2. Packing Form**

a) Package quantity in one box : 7ea

b) Box Size : 747mm X 335mm X 466mm

**Product Specification****9. PRECAUTIONS**

Please pay attention to the followings when you use this TFT LCD module.

**9-1. MOUNTING PRECAUTIONS**

- (1) You must mount a module using holes arranged in four corners or four sides.
- (2) You should consider the mounting structure so that uneven force (ex. Twisted stress) is not applied to the module. And the case on which a module is mounted should have sufficient strength so that external force is not transmitted directly to the module.
- (3) Please attach the surface transparent protective plate to the surface in order to protect the polarizer. Transparent protective plate should have sufficient strength in order to resist external force.
- (4) You should adopt radiation structure to satisfy the temperature specification.
- (5) Acetic acid type and chlorine type materials for the cover case are not desirable because the former generates corrosive gas of attacking the polarizer at high temperature and the latter causes circuit break by electro-chemical reaction.
- (6) Do not touch, push or rub the exposed polarizers with glass, tweezers or anything harder than HB pencil lead. And please do not rub with dust clothes with chemical treatment. Do not touch the surface of polarizer for bare hand or greasy cloth. (Some cosmetics are detrimental to the polarizer.)
- (7) When the surface becomes dusty, please wipe gently with absorbent cotton or other soft materials like chamois soaks with petroleum benzene. Normal-hexane is recommended for cleaning the adhesives used to attach front / rear polarizers. Do not use acetone, toluene and alcohol because they cause chemical damage to the polarizer.
- (8) Wipe off saliva or water drops as soon as possible. Their long time contact with polarizer causes deformations and color fading.
- (9) Do not open the case because inside circuits do not have sufficient strength.

**9-2. OPERATING PRECAUTIONS**

- (1) The spike noise causes the miss-operation of circuits. It should be lower than following voltage :  
 $V = \pm 200\text{mV}$  (Over and under shoot voltage)
- (2) Response time depends on the temperature. (In lower temperature, it becomes longer.)
- (3) Brightness depends on the temperature. (In higher temperature, it becomes lower.)  
And in lower temperature, response time (required time that brightness is stable after turned on) becomes longer.
- (4) Be careful for condensation at sudden temperature change. Condensation makes damage to polarizer or electrical contacted parts. And after fading condensation, smear or spot will occur.
- (5) When fixed patterns are displayed for a long time, remnant image is likely to occur.
- (6) Module has high frequency circuits. Sufficient suppression to the electromagnetic interference shall be done by system manufacturers. Grounding and shielding methods may be important to minimized the interference.
- (7) Please do not give any mechanical and/or acoustical impact to LCM. Otherwise, LCM can't be operated its full characteristics perfectly.
- (8) A screw which is fastened up the steels should be a machine screw.  
(if not, it causes metallic foreign material and deal LCM a fatal blow)
- (9) Please do not set LCD on its edge.

**Product Specification****9-3. ELECTROSTATIC DISCHARGE CONTROL**

Since a module is composed of electronic circuits, it is not strong to electrostatic discharge. Make certain that treatment persons are connected to ground through wrist band etc. And don't touch interface pin directly.

**9-4. PRECAUTIONS FOR STRONG LIGHT EXPOSURE**

Strong light exposure causes degradation of polarizer and color filter.

**9-5. STORAGE**

When storing modules as spares for a long time, the following precautions are necessary.

- (1) Store them in a dark place. Do not expose the module to sunlight or fluorescent light. Keep the temperature between 5°C and 35°C at normal humidity.
- (2) The polarizer surface should not come in contact with any other object.  
It is recommended that they be stored in the container in which they were shipped.

**9-6. HANDLING PRECAUTIONS FOR PROTECTION FILM**

- (1) The protection film is attached to the bezel with a small masking tape.  
When the protection film is peeled off, static electricity is generated between the film and polarizer.  
This should be peeled off slowly and carefully by people who are electrically grounded and with well ion-blown equipment or in such a condition, etc.
- (2) When the module with protection film attached is stored for a long time, sometimes there remains a very small amount of glue still on the bezel after the protection film is peeled off.
- (3) You can remove the glue easily. When the glue remains on the bezel surface or its vestige is recognized, please wipe them off with absorbent cotton waste or other soft material like chamois soaked with normal-hexane.





**LM270WQ1**  
**Liquid Crystal Display**

**Product Specification**

**10. EDID DATA FOR LM240WU6-SDA1**

**10-1. EDID Data**

LM270WQ1-SDC2 EDID DATA (2560X1440 @ 60Hz)						Modified 2010.03.12
Byte# (decimal)	Byte# (HEX)	Field Name and Comments	Value (HEX)	Value (binary)	Value (DEC)	
0	00	Header	00	00000000	0	
1	01	Header	FF	11111111	255	Header
2	02	Header	FF	11111111	255	
3	03	Header	FF	11111111	255	
4	04	Header	FF	11111111	255	
5	05	Header	FF	11111111	255	
6	06	Header	FF	11111111	255	
7	07	Header	00	00000000	0	
8	08	EISA manufacture code ( 3 Character ID )	APP	06	00000110	6
9	09	EISA manufacture code (Compressed ASC II)		10	00010000	16
10	0A	Panel Supplier Reserved - Product Code	3cd7H	D7	11010111	215
11	0B	(Hex. LSB first)		9C	10011100	156
12	0C	32-bit serial #		00	00000000	0
13	0D			00	00000000	0
14	0E			00	00000000	0
15	0F			00	00000000	0
16	10	Week of Manufacture		0B	00001000	8
17	11	Year of Manufacture	2009 years	14	00010100	20
18	12	EDID structure version # = 1		01	00000001	1
19	13	EDID revision # = 4		04	00000100	4
20	14	Video input Definition = DisplayPort 8bit		A5	10100101	165
21	15	Max H image size (Rounded cm) = 60 cm		3C	00111100	60
22	16	Max V image size (Rounded cm) = 34 cm		22	00100010	34
23	17	Display gamma = (gamma*100)-100 = Example(2.2*100)-100		78	01111000	120
24	18	Feature Support 1: Display Power Management(DPM) : No_StandbyNo_Suspend Other Feature Support Flags : No_sRGB, Preferred Timing Mode, No_Display is continuous frequency (Multi-mode Base EDID and Extension Block.)		22	00100010	34
25	19	Red/Green Low Bits (Rr/Ry/Gr/Gy)		6F	01101111	111
26	1A	Blue/White Low Bits (Bb/By/Wb/Wy)		B1	10110001	177
27	1B	Red X Rx = 0.653		A7	10100111	167
28	1C	Red Y Ry = 0.334		55	01010101	85
29	1D	Green X Gx = 0.30		4C	01001100	76
30	1E	Green Y Gy = 0.620		9E	10011110	158
31	1F	Blue X Bx = 0.146		25	00100101	37
32	20	Blue Y By = 0.050		0C	00001100	12
33	21	White X Wx = 0.313		50	01010000	80
34	22	White Y Wy = 0.329		54	01010100	84
35	23	Established timing 1 (00h if not used)		00	00000000	0
36	24	Established timing 2 (00h if not used)		00	00000000	0
37	25	Manufacturer's timings		00	00000000	0
38	26	Standard timing ID1 (01h if not used)		01	00000001	1
39	27	Standard timing ID1 (01h if not used)		01	00000001	1
40	28	Standard timing ID2 (01h if not used)		01	00000001	1
41	29	Standard timing ID2 (01h if not used)		01	00000001	1
42	2A	Standard timing ID3 (01h if not used)		01	00000001	1
43	2B	Standard timing ID3 (01h if not used)		01	00000001	1
44	2C	Standard timing ID4 (01h if not used)		01	00000001	1
45	2D	Standard timing ID4 (01h if not used)		01	00000001	1
46	2E	Standard timing ID5 (01h if not used)		01	00000001	1
47	2F	Standard timing ID5 (01h if not used)		01	00000001	1
48	30	Standard timing ID6 (01h if not used)		01	00000001	1
49	31	Standard timing ID6 (01h if not used)		01	00000001	1
50	32	Standard timing ID7 (01h if not used)		01	00000001	1
51	33	Standard timing ID7 (01h if not used)		01	00000001	1
52	34	Standard timing ID8 (01h if not used)		01	00000001	1
53	35	Standard timing ID8 (01h if not used)		01	00000001	1
54	36	Detailed timing/monitor		56	01010110	86
55	37	Pixel Clock = 241.5 MHz		5E	01011110	94
56	38	Hor active= 2560 pixels		00	00000000	0
57	39	Hor blanking= 160 pixels		A0	10100000	160
58	3A			A0	10100000	160
59	3B	Vertical active= 1440 lines		A0	10100000	160
60	3C	Vertical blanking= 41 lines		29	00101001	41
61	3D			50	01010000	80
62	3E	H sync. Offset= 48 pixels		30	00110000	48
63	3F	H sync. Width= 32 pixels		20	00100000	32
64	40	V sync. Offset=3 lines		35	00110101	53
65	41	V sync. Width= 5 lines		00	00000000	0
66	42	H image size= 597 mm		55	01010101	85
67	43	V image size = 336 mm		50	01010000	80
68	44			21	00100001	33
69	45	No Horizontal Border		00	00000000	0
70	46	No Vertical Border		00	00000000	0
71	47	Non-Interlace, Normal display, no stereo, Digital Separate   Vsync_NEG, Hsync_POS		1A	00011010	26



**LM270WQ1**  
Liquid Crystal Display

**Product Specification**

72	48	1280x720p Timing	1A	00011010	26	
73	49	Pixel Clock = 74.5 MHz	1D	00011101	29	
74	4A	Horizontal Active = 1280 Pixels	00	00000000	0	
75	4B	Horizontal Blanking = 384 Pixels	80	10000000	128	
76	4C		51	01010001	81	
77	4D	Vertical Active = 720 Lines	D0	11010000	208	
78	4E	Vertical Blanking = 28 Lines	1C	00011100	28	
79	4F		20	00100000	32	
80	50	Horizontal Sync. Offset = 64 Pixels	40	01000000	64	
81	51	Horizontal Sync. Pulse Width = 128 Pixels	80	10000000	128	
82	52	V sync. Offset=3 lines	35	00110101	53	
83	53	V sync. Width= 5 lines	00	00000000	0	
84	54	H image size= 597 mm	55	01010101	85	
85	55	V image size = 336 mm	50	01010000	80	
86	56		21	00100001	33	
87	57	No Horizontal Border	00	00000000	0	
88	58	No Vertical Border	00	00000000	0	
89	59	Non-Interlace, Normal display, no stereo, Digital Separate   Vsync_NEG, Hsync_POS	1C	00011100	28	
90	5A	Detailed timing/monitor descriptor #3	00	00000000	0	
91	5B		00	00000000	0	
92	5C		00	00000000	0	
93	5D		02	00000010	2	
94	5E		01	00000001	1	
95	5F		06	00000110	6	
96	60		10	00010000	16	
97	61		01	00000001	1	
98	62		0A	00001010	10	
99	63		01	00000001	1	
100	64		00	00000000	0	
101	65		00	00000000	0	
102	66		00	00000000	0	
103	67		00	00000000	0	
104	68		00	00000000	0	
105	69		00	00000000	0	
106	6A		00	00000000	0	
107	6B		00	00000000	0	
108	6C	Detailed timing/monitor descriptor #4	00	00000000	0	
109	6D		00	00000000	0	
110	6E	Color LCD	00	00000000	0	
111	6F		FC	11111100	252	
112	70		00	00000000	0	
113	71	C	43	01000011	67	
114	72	o	6F	01101111	111	
115	73	l	6C	01101100	108	
116	74	o	6F	01101111	111	
117	75	r	72	01110010	114	
118	76		20	00100000	32	
119	77	L	4C	01001100	76	
120	78	C	43	01000011	67	
121	79	D	44	01000100	68	
122	7A		0A	00001010	10	
123	7B		20	00100000	32	
124	7C		20	00100000	32	
125	7D		20	00100000	32	
126	7E	Extension Flag = 01	01	00000001	1	Extension Flag
127	7F	<b>Checksum</b>	<b>F9</b>	<b>11111001</b>	<b>249</b>	<b>Checksum</b>
128	80	Tag	02	00000010	2	
129	81	Revision Number	03	00000011	3	
130	82	Offset of first Detailed Timing Description	0C	00001100	12	
131	83	Device Support & No. of Native Formats	C1	11000001	193	
132	84	Audio Data Block Tag	23	00100011	35	
133	85	CEA Short Video Descriptor 1	09	00001001	9	
134	86	Audio Data Block Tag	07	00000111	7	
135	87	CEA Short Audio Descriptor 1	07	00000111	7	
136	88	Speaker Allocation Data Block Tag	83	10000011	131	
137	89		01	00000001	1	
138	8A	Speaker Allocation Payload	00	00000000	0	
139	8B		00	00000000	0	
140	8C	Detailed timing/monitor	56	01010110	86	
141	8D	Pixel Clock = 241.5 MHz	5E	01011110	94	
142	8E	Hor active= 2560 pixels	00	00000000	0	
143	8F	Hor blanking= 160 pixels	A0	10100000	160	
144	90		A0	10100000	160	
145	91	Vertical active= 1440 lines	A0	10100000	160	
146	92	Vertical blanking= 41 lines	29	00101001	41	

Detailed  
Timing  
Description  
#2

Detailed  
Timing  
Description  
#3

Ascii Data String:  
LM270WQ1-SDA2

Detailed  
Timing  
Description  
#4

Monitor Name:  
Color LCD

Extension Flag

Checksum



**LM270WQ1**  
Liquid Crystal Display

## Product Specification

147	93		50	01010000	80
148	94	H sync. Offset= 48 pixels	30	00110000	48
149	95	H sync. Width= 32 pixels	20	00100000	32
150	96	V sync. Offset=3 lines	35	00110101	53
151	97	V sync. Width= 5 lines	00	00000000	0
152	98	H image size= 597 mm	55	01010101	85
153	99	V image size = 336 mm	50	01010000	80
154	9A		21	00100001	33
155	9B	No Horizontal Border	00	00000000	0
156	9C	No Vertical Border	00	00000000	0
157	9D	Non-interlaced, Normal display, No stereo, Digital separate sync, H/V pol Negatives	1A	00011010	26
158	9E	1280x720p Timing	1A	00011010	26
159	9F	Pixel Clock = 74.5 MHz	1D	00011101	29
160	A0	Horizontal Active = 1280 Pixels	00	00000000	0
161	A1	Horizontal Blanking = 384 Pixels	80	10000000	128
162	A2		51	01010001	81
163	A3	Vertical Active = 720 Lines	D0	11010000	208
164	A4	Vertical Blanking = 28 Lines	1C	00011100	28
165	A5		20	00100000	32
166	A6	Horizontal Sync. Offset = 64 Pixels	40	01000000	64
167	A7	Horizontal Sync Pulse Width = 128 Pixels	80	10000000	128
168	A8	V sync. Offset=3 lines	35	00110101	53
169	A9	V sync. Width= 5 lines	00	00000000	0
170	AA	H image size= 597 mm	55	01010101	85
171	AB	V image size = 336 mm	50	01010000	80
172	AC		21	00100001	33
173	AD	No Horizontal Border	00	00000000	0
174	AE	No Vertical Border	00	00000000	0
175	AF	ce, Normal display, no stereo, Digital Separate ( Vsync_POS, Hs	1C	00011100	28
176	B0		00	00000000	0
177	B1		00	00000000	0
178	B2		00	00000000	0
179	B3		00	00000000	0
180	B4		00	00000000	0
181	B5		00	00000000	0
182	B6		00	00000000	0
183	B7		00	00000000	0
184	B8		00	00000000	0
185	B9		00	00000000	0
186	BA		00	00000000	0
187	BB		00	00000000	0
188	BC		00	00000000	0
189	BD		00	00000000	0
190	BE		00	00000000	0
191	BF		00	00000000	0
192	C0		00	00000000	0
193	C1		00	00000000	0
194	C2		00	00000000	0
195	C3		00	00000000	0
196	C4		00	00000000	0
197	C5		00	00000000	0
198	C6		00	00000000	0
199	C7		00	00000000	0
200	C8		00	00000000	0
201	C9		00	00000000	0
202	CA		00	00000000	0
203	CB		00	00000000	0
204	CC		00	00000000	0
205	CD		00	00000000	0
206	CE		00	00000000	0
207	CF		00	00000000	0
208	D0		00	00000000	0
209	D1		00	00000000	0
210	D2		00	00000000	0
211	D3		00	00000000	0
212	D4		00	00000000	0
213	D5		00	00000000	0
214	D6		00	00000000	0
215	D7		00	00000000	0
216	D8		00	00000000	0
217	D9		00	00000000	0
218	DA		00	00000000	0
219	DB		00	00000000	0
220	DC		00	00000000	0
221	DD		00	00000000	0
222	DE		00	00000000	0
223	DF		00	00000000	0
224	E0		00	00000000	0
225	E1		00	00000000	0

## Product Specification

226	E2	00	00000000	0
227	E3	00	00000000	0
228	E4	00	00000000	0
229	E5	00	00000000	0
230	E6	00	00000000	0
231	E7	00	00000000	0
232	E8	00	00000000	0
233	E9	00	00000000	0
234	EA	00	00000000	0
235	EB	00	00000000	0
236	EC	00	00000000	0
237	ED	00	00000000	0
238	EE	00	00000000	0
239	EF	00	00000000	0
240	F0	00	00000000	0
241	F1	00	00000000	0
242	F2	00	00000000	0
243	F3	00	00000000	0
244	F4	00	00000000	0
245	F5	00	00000000	0
246	F6	00	00000000	0
247	F7	00	00000000	0
248	F8	00	00000000	0
249	F9	00	00000000	0
250	FA	00	00000000	0
251	FB	00	00000000	0
252	FC	00	00000000	0
253	FD	00	00000000	0
254	FE	00	00000000	0
255	FF	13	00010011	0

## 10-2. EDID DATA READ/WRITE PROTOCOL

### 10-2-1. READ Operation

<Start><Slave Address, RW=0><Byte Address><Start><Slave Address, RW=1><Data><Stop>

### 10-2-2. WRITE Operation

<Start><Slave Address, RW=0><Byte Address><Data><Stop>

#### - Device Address (Slave Address)

Type	Device (Slave) Address							Hex	
IS24C02B	1	0	1	0	0	0	0	RW	0xA0 + RW

#### - Byte Address

Byte Address	
Decimal	0 ~ 127
Hex	0x00 ~ 0x7F