

Product Specification

SPECIFICATION FOR APPROVAL

- () Preliminary Specification
 (◆) Final Specification

Title	27.0" QHD TFT LCD
-------	-------------------

BUYER	HP
MODEL	-

SUPPLIER	LG Display Co., Ltd.
*MODEL	LM270WQ1
SUFFIX	Sddb

*When you obtain standard approval,
 please use the above model name without suffix

APPROVED BY	SIGNATURE DATE
/	/
<div style="display: flex; align-items: center;"> <div style="font-size: 2em; margin-right: 10px;">charles cheng</div> <div style="font-size: 2em; color: red; margin-right: 10px;">/</div> <div style="font-size: 0.8em;"> 數位簽署者 : charles cheng DN : ou=DUNS - 65-873-1930, o=PEGATRON CORPORATION, ou=Individuals G2, ou=Terms of Use at www.verisign.com/rpa (c)00, cn=charles cheng, email=charles_cheng@pegatroncorp.com 日期 : 2011.12.23 16:49:44 +08'00' </div> </div>	/
/	/
Please return 1 copy for your confirmation with your signature and comments.	

APPROVED BY	SIGNATURE DATE
K. G. Park / G.Manager	/
REVIEWED BY	
S. W. Lee / Manager [C]	/
Y. S. Chung / Manager[M]	/
D. H. Kang / Manager [P]	/
PREPARED BY	
J. A. Lee / Engineer	/
MNT Products Engineering Dept. LG Display Co., Ltd	

Product Specification
Contents

No	ITEM	Page
	COVER	1
	CONTENTS	2
	RECORD OF REVISIONS	3
1	GENERAL DESCRIPTION	4
2	ABSOLUTE MAXIMUM RATINGS	5
3	ELECTRICAL SPECIFICATIONS	6
3-1	ELECTRICAL CHARACTERISTICS	6
3-2	INTERFACE CONNECTIONS	9
3-3	SIGNAL TIMING SPECIFICATIONS	11
3-4	SIGNAL TIMING WAVEFORMS	12
3-5	COLOR INPUT DATA REFERENCE	13
3-6	POWER SEQUENCE	14
4	OPTICAL SPECIFICATIONS	16
5	MECHANICAL CHARACTERISTICS	22
6	RELIABILITY	25
7	INTERNATIONAL STANDARDS	26
7-1	SAFETY	26
7-2	EMC	26
7-3	ENVIRONMENT	30
8	PACKING	27
8-1	DESIGNATION OF LOT MARK	27
8-2	PACKING FORM	27
9	PRECAUTIONS	28
9-1	MOUNTING PRECAUTIONS	28
9-2	OPERATING PRECAUTIONS	28
9-3	ELECTROSTATIC DISCHARGE CONTROL	29
9-4	PRECAUTIONS FOR STRONG LIGHT EXPOSURE	29
9-5	STORAGE	29
9-6	HANDLING PRECAUTIONS FOR PROTECTION FILM	29

Product Specification

1. General Description

LM270WQHD is a Color Active Matrix Liquid Crystal Display with Light Emitting Diode (White LED) backlight system without LED driver. The matrix employs a-Si Thin Film Transistor as the active element. It is a transmissive type display operating in the normally black mode. It has a 27inch diagonally measured active display area with QHD resolution (2560 vertical by 1440 horizontal pixel array) Each pixel is divided into Red, Green and Blue sub-pixels or dots which are arranged in vertical stripes. Gray scale or the brightness of the sub-pixel color is determined with a 10-bit gray scale signal for each dot, thus, presenting a palette of more than 1.07B colors with FRC (Frame Rate Control).

It has been designed to apply the 10-bit 4Lane Display port interface.

It is intended to support displays where high brightness, super wide viewing angle, high color saturation, and high color are important.

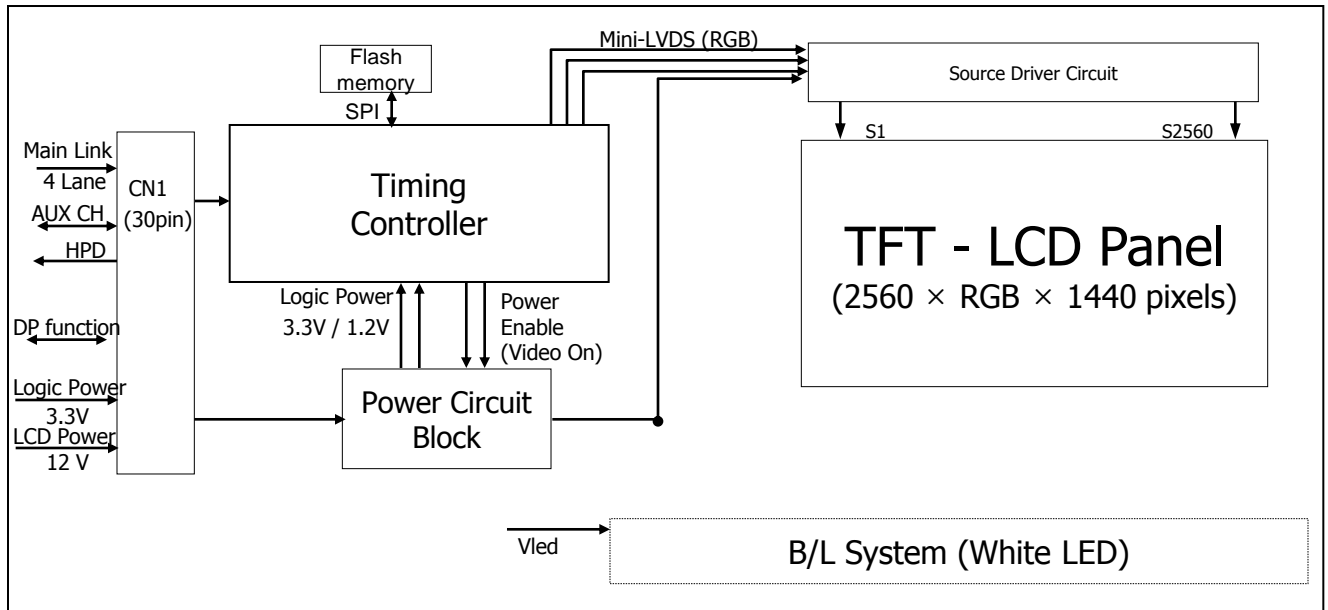

General Features

Active Screen Size	27.0 inches(68.47cm) diagonal
Outline Dimension	630.0(H) x 376.13(V) x 21.8(D) mm(Typ.)
Pixel Pitch	0.2331 mm x 0.2331 mm
Pixel Format	2560 horiz. By 1440 vert. Pixels RGB stripes arrangement
Color Depth	1.07 Billion colors, 8Bit with A-FRC
Luminance, White	380 cd/m ² (Center 1Point, Typ.)
Viewing Angle(CR>10)	View Angle Free (R/L 178(Typ.), U/D 178(Typ.))
Power Consumption	Total 90.69 Watt (Max.) (15.36 Watt @VLCD, Max 75.33 Watt_Duty 100% of DC 310 mA_w/o driver)
Weight	4,600g (typ.)
Display Operating Mode	Transmissive mode, normally black
Surface Treatment	Advanced Anti-Glare treatment of the front polarizer
HDCP	HDCP key implemented in Tcon (DP628)

Product Specification

2. Absolute Maximum Ratings

The following are maximum values which, if exceeded, may cause faulty operation or damage to the unit.

Table 1. ABSOLUTE MAXIMUM RATINGS

Parameter	Symbol	Values		Units	Notes
		Min	Max		
Power Input Voltage	VLCD	-0.3	14	Vdc	at 25 ± 2°C
Power Input Voltage	VDPLGIC	-0.5	4	Vdc	at 25 ± 2°C
Operating Temperature	TOP	0	50	°C	1, 2
Storage Temperature	TST	-20	60	°C	
Operating Ambient Humidity	HOP	10	90	%RH	
Storage Humidity	HST	10	90	%RH	

Note : 1. Temperature and relative humidity range are shown in the figure below.

Wet bulb temperature should be 39 °C Max, and no condensation of water.

2. Storage condition is guaranteed under packing condition

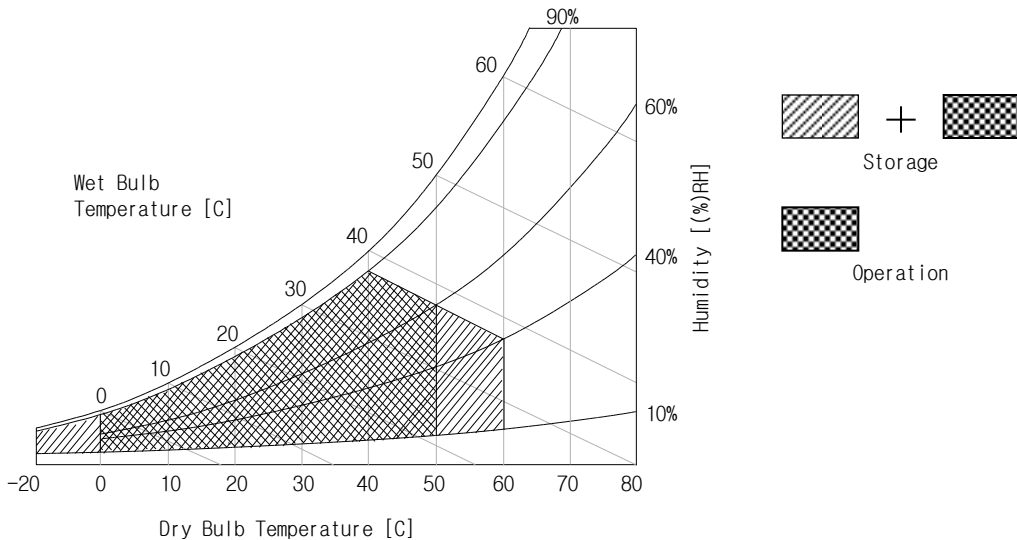

Product Specification
3. Electrical Specifications
3-1. Electrical Characteristics

It requires two power inputs. One is employed to power the LCD electronics and to drive the TFT array and liquid crystal. The second input power for the DP Rx.

Table 2-1-1. ELECTRICAL CHARACTERISTICS (Normal Mode)

Parameter	Symbol	Values			Unit	Notes
		Min	Typ	Max		
MODULE :						
Power Supply Input voltage	VLCD	11.4	12.0	12.6	Vdc	
Permissive Power Input Ripple	VRF_VLCD	-	-	400	mVp-p	
Power Supply Input Current	ILCD	-	890	1025	mA	1
		-	1280	1475	mA	2
Power Consumption	PLCD	-	10.68	12.30	Watt	1
			15.36	17.70	Watt	2
Rush Current	IRUSH_VLCD	-	-	3.0	A	3
DP Logic Input Voltage	VCC_L_IN	3.13	3.3	3.47	Vdc	
Permissive Logic Input Ripple	VRF_VCC_L_IN	-	-	100	mVp-p	
DP Logic Input Current	I_VCC_L_IN		300		mA	1
			300		mA	2
DP Logic Power Consumption	P_VCC_L_IN		1.0		Watt	
DP Rush Current	IRUSH_VCC_L_IN	-	-	1.0	A	3

Product Specification

Note :

1. The specified current and power consumption are under the $V_{LCD}=12.0V$, $25 \pm 2^{\circ}C$, $f_V=60Hz$ condition whereas mosaic pattern(8 x 6) is displayed and f_V is the frame frequency.
2. The current is specified at the maximum current pattern.
3. The duration of rush current is about 2ms and rising time of power Input is 1ms(min.).

White : 255Gray
Black : 0Gray

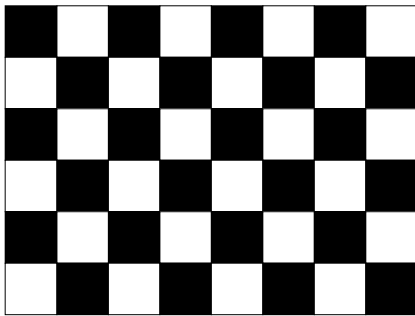

Mosaic Pattern(8 x 6)

Maximum current pattern



White Pattern

Product Specification
Table 2-2. LED Bar ELECTRICAL CHARACTERISTICS

Items	Symbol	Spec			Unit	Remark	Notes
		Min	Typ	Max			
LED String Current	I_S	-	310	330	mA	Ta=25°C	1
LED String Voltage	V_S	30.5	35.5	40.5	V	Ta=25°C, at Duty 100% of DC 310 mA	2,6
LED String Power	P_S	9.46	11.01	12.56	W		5,6
BL Power	P_{BL}	-	66.03	75.33	W		3,5,6
LED Life Time	LED_LT	(39,000)		-	Hrs		4,6

LED driver design guide

: The design of the LED driver must have specifications for the LED in LCD Assembly.

The performance of the LED in LCM, for example life time or brightness, is extremely influenced by the characteristics of the LED driver.

So all the parameters of an LED driver should be carefully designed and output current should be Constant current control.

Please control feedback current of each string individually to compensate the current variation among the strings of LEDs.

When you design or order the LED driver, please make sure unwanted lighting caused by the mismatch of the LED and the LED driver (no lighting, flicker, etc) never occurs.

When you confirm it, the LCD module should be operated in the same condition as installed in your instrument.

※ Specified values are for a single LED bar including Left & Right Bar.

1. The specified current is input LED chip 100% duty current.
2. The specified voltage is input LED string and Bar voltage at typical 310 mA 100% duty current.
3. The specified power consumption is input BL power consumption at typical 310 mA 100% duty current.
4. The life is determined as the time at which luminance of the LED is 50% compared to that of initial value at the typical LED current on condition of continuous operating at $25 \pm 2^\circ\text{C}$.
5. The LED power consumption shown above does not include loss of external driver.

The used LED BL current is the LED typical current.

String Power Consumption is calculated with $P_S = V_S \times \text{typical current (mA)}$

BL Power Consumption is calculated with $P_{BL} = P_S \times \text{the number of string}$

6. LED operating DC Forward Current must not exceed LED Max Ratings.

Product Specification

3-2. Interface Connections

3-2-1. LCD Module

- LCD Connector(CN1). : FI-X30SSL-HF (manufactured by JAE)
 The pin configuration for the 30 pin connector is shown in the table below.

Table 3 MODULE CONNECTOR(CN_SIG) PIN CONFIGURATION

Pin No.	Symbol	Description	Pin No.	Symbol	Description
1	DDC_SCL	DDC for Clock	16	Lane3P	True Signal for Main Link 3
2	DDC_SDA	DDC for Data	17	Lane3N	Component Signal for Main Link 3
3	GND	High Speed Ground for Auxiliary Channel	18	GND	High Speed Ground
4	AUX_CH N	Component Signal for Auxiliary Channel	19	SPDIF	Audio output from DP RX
5	AUX_CH P	True Signal for Auxiliary Channel	20	VIDEO_ON	Video status from DP RX
6	GND	High Speed Ground for Main Link 0	21	HPD	Hot Plug Detect Signal
7	Lane0P	True Signal for Main Link 0	22	GND	GND for main power
8	Lane0N	Component Signal for Main Link 0	23	GND	GND for main power
9	GND	High Speed Ground for Main Link 1	24	GND	GND for main power
10	Lane1P	True Signal for Main Link 1	25	GND	GND for main power
11	Lane1N	Component Signal for Main Link 1	26	VLCD	12V for LCM main power
12	GND	High Speed Ground for Main Link 2	27	VLCD	12V for LCM main power
13	Lane2P	True Signal for Main Link 2	28	VLCD	12V for LCM main power
14	Lane2N	Component Signal for Main Link 2	29	VLCD	12V for LCM main power
15	GND	High Speed Ground for Main Link 3	30	VCC_L_IN	3.3V for DP TCON power

Notes : 1. Connector

2.1 Connector(Receptacle) : FI-X30SSL-HF(JAE) or 20389-Y30E-01(I-PEX)

2.2 Mating Connector(Plug) : FI-X30HL(JAE) or 20385-Y30T-12F(I-PEX)

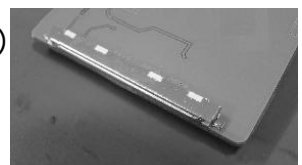

Product Specification

3-2-2. Backlight Interface

- LED Connector : **H401K-D12N-12B** (Manufactured by E&T)
- Mating Connector : **4530K-F12N-01R** (Manufactured by E&T)

Table 5. LED CONNECTOR PIN CONFIGURATION

Pin No.	Symbol	Description	Note
1	L_LED1+	LED channel 1 Anode	Left bar
2	L_LED1-	LED channel 1 Cathode	
3	L_LED2+	LED channel 2 Anode	
4	L_LED2-	LED channel 2 Cathode	
5	L_LED3+	LED channel 3 Anode	
6	L_LED3-	LED channel 3 Cathode	
7	R_LED1+	LED channel 1 Anode	Right bar
8	R_LED1-	LED channel 1 Cathode	
9	R_LED2+	LED channel 2 Anode	
10	R_LED2-	LED channel 2 Cathode	
11	R_LED3+	LED channel 3 Anode	
12	R_LED3-	LED channel 3 Cathode	

3-2-3. Sync Connector

This connector is used for synchronized LED Driver.
 The connector is 53780-8604. (Manufactured by MOLEX)

Table 5. LED SYNCHRONIZED CONNECTOR(CN4) PIN CONFIGURATION

Pin	Symbol	Description	NOTES
1	GND	Ground	
2	ENBLT	Enable	
3	PWM	PWM for synchronized LED Driver	1
4	I_RES	GSP for synchronized LED Driver	2

Note: 1. PWM signal follows multiplied Horizontal frequency and level is 3.3V TTL level.
 2. GSP frequency follows refresh time and level is 3.3V TTL level
 and high width is 1/(Horizontal freq).

Product Specification
3-3. Signal Timing Specifications

All of the interface signal timing should be satisfied with the following specifications for its proper operation.

Table 6. TIMING TABLE (VESA COORDINATED VIDEO TIMING)

ITEM		SYMBOL	Min	Typ	Max	Unit	Note
DCLK	Period	tCLK	4.14	4.14	4.14	ns	
	Frequency	fCLK	241.5	241.5	241.5	MHz	-
Hsync	Period	tHP	2720	2720	2720	tCLK	
	Width-Active	tWH	32	32	32		
Vsync	Period	tVP	1481	1481	1481	tHP	
	Frequency	fV	59.95	59.95	59.95	Hz	
	Width-Active	tWV	5	5	5	tHP	
Data Enable	Horizontal Valid	tHV	2560	2560	2560	tCLK	
	Horizontal Back Porch	tHBP	80	80	80		
	Horizontal Front Porch	tHFP	48	48	48		
	Horizontal Blank	-	160	160	160		tWH+ tHBP+ tHFP
	Vertical Valid	tVV	1440	1440	1440	tHP	
	Vertical Back Porch	tVBP	33	33	33		
	Vertical Front Porch	tVFP	3	3	3		
	Vertical Blank	-	41	41	41		tWV+ tVBP+ tVFP

Note: Hsync period and Hsync width-active should be even number times of tCLK. If the value is odd number times of tCLK, display control signal can be asynchronous. In order to operate this LCM a Hsync, Vsync, and DE(data enable) signals should be used.

1. The performance of the electro-optical characteristics may be influenced by variance of the vertical refresh rates.
2. Vsync and Hsync should be keep the above specification.
3. Hsync Period, Hsync Width, and Horizontal Back Porch should be any times of of character number(8).
4. The polarity of Hsync, Vsync is not restricted.

Product Specification

3-4. Signal Timing Waveforms

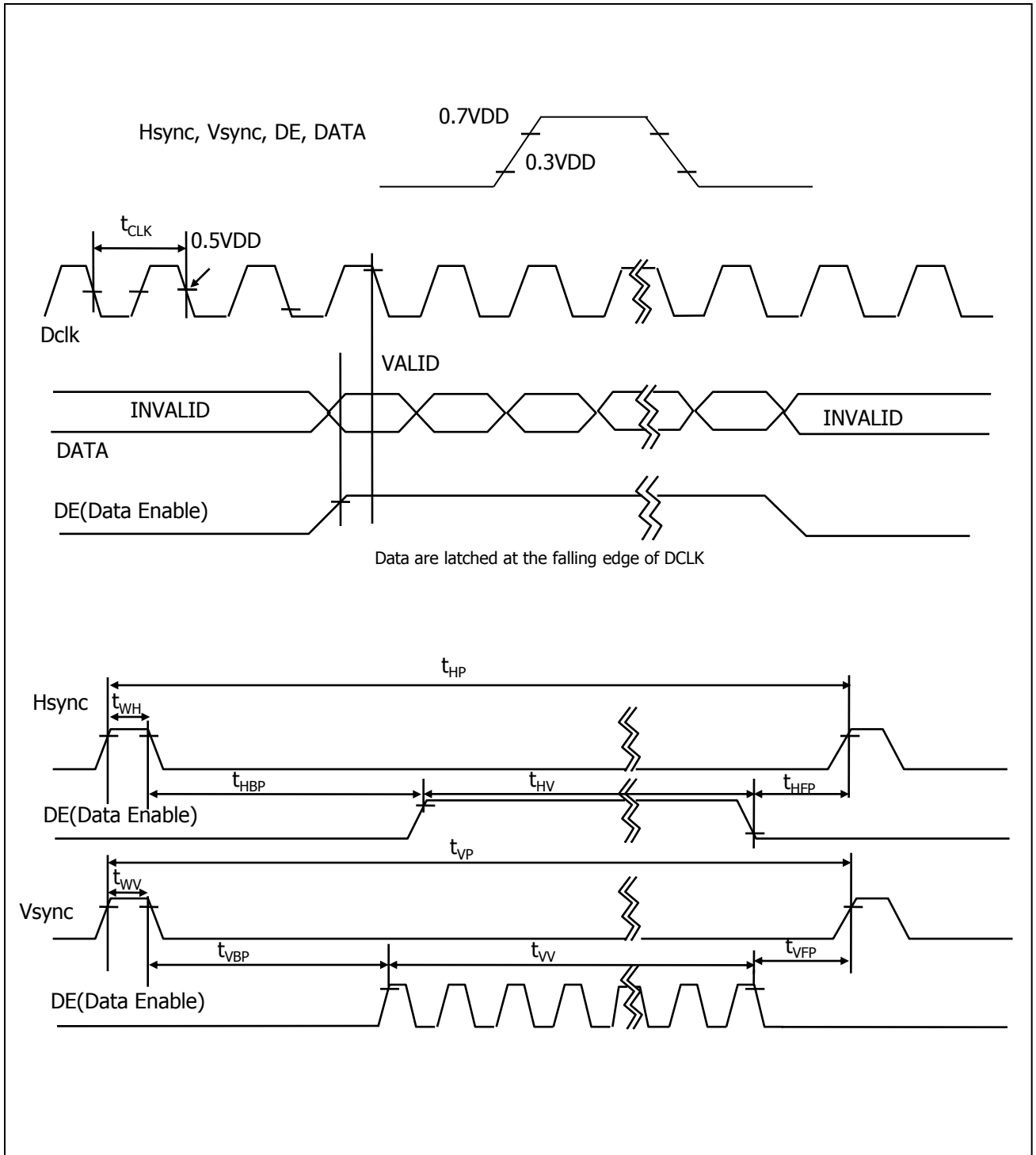

Product Specification
3-5. Color Data Reference

The Brightness of each primary color(red,green,blue) is based on the 10-bit gray scale data input for the color; the higher the binary input, the brighter the color. The table below provides a reference for color versus data input.

Table 5. COLOR DATA REFERENCE

Color		Input Color Data																													
		RED										GREEN										BLUE									
		MSB					LSB					MSB					LSB					MSB					LSB				
		R9	R8	R7	R6	R5	R4	R3	R2	R1	R0	G9	G8	G7	G6	G5	G4	G3	G2	G1	G0	B9	B8	B7	B6	B5	B4	B3	B2	B1	B0
Basic Color	Black	0	0	0	0	0	0	0	0	0	0	0	0	0	0	0	0	0	0	0	0	0	0	0	0	0	0	0	0	0	0
	Red (1023)	1	1	1	1	1	1	1	1	1	1	0	0	0	0	0	0	0	0	0	0	0	0	0	0	0	0	0	0	0	0
	Green (1023)	0	0	0	0	0	0	0	0	0	0	1	1	1	1	1	1	1	1	1	1	0	0	0	0	0	0	0	0	0	0
	Blue (1023)	0	0	0	0	0	0	0	0	0	0	0	0	0	0	0	0	0	0	0	0	1	1	1	1	1	1	1	1	1	1
	Cyan	0	0	0	0	0	0	0	0	0	0	1	1	1	1	1	1	1	1	1	1	1	1	1	1	1	1	1	1	1	1
	Magenta	1	1	1	1	1	1	1	1	1	1	0	0	0	0	0	0	0	0	0	0	1	1	1	1	1	1	1	1	1	1
	Yellow	1	1	1	1	1	1	1	1	1	1	1	1	1	1	1	1	1	1	1	1	0	0	0	0	0	0	0	0	0	0
	White	1	1	1	1	1	1	1	1	1	1	1	1	1	1	1	1	1	1	1	1	1	1	1	1	1	1	1	1	1	1
RED	RED (000)	0	0	0	0	0	0	0	0	0	0	0	0	0	0	0	0	0	0	0	0	0	0	0	0	0	0	0	0	0	0
	RED (001)	0	0	0	0	0	0	0	0	0	1	0	0	0	0	0	0	0	0	0	0	0	0	0	0	0	0	0	0	0	0
	...																														
	RED (1022)	1	1	1	1	1	1	1	1	1	0	0	0	0	0	0	0	0	0	0	0	0	0	0	0	0	0	0	0	0	0
	RED (1023)	1	1	1	1	1	1	1	1	1	1	0	0	0	0	0	0	0	0	0	0	0	0	0	0	0	0	0	0	0	0
GREEN	GREEN (000)	0	0	0	0	0	0	0	0	0	0	0	0	0	0	0	0	0	0	0	0	0	0	0	0	0	0	0	0	0	0
	GREEN (001)	0	0	0	0	0	0	0	0	0	0	0	0	0	0	0	0	0	0	0	1	0	0	0	0	0	0	0	0	0	0
	...																														
	GREEN (1022)	0	0	0	0	0	0	0	0	0	0	1	1	1	1	1	1	1	1	1	0	0	0	0	0	0	0	0	0	0	0
	GREEN (1023)	0	0	0	0	0	0	0	0	0	0	1	1	1	1	1	1	1	1	1	1	0	0	0	0	0	0	0	0	0	0
BLUE	BLUE (000)	0	0	0	0	0	0	0	0	0	0	0	0	0	0	0	0	0	0	0	0	0	0	0	0	0	0	0	0	0	0
	BLUE (001)	0	0	0	0	0	0	0	0	0	0	0	0	0	0	0	0	0	0	0	0	0	0	0	0	0	0	0	0	0	1
	...																														
	BLUE (1022)	0	0	0	0	0	0	0	0	0	0	0	0	0	0	0	0	0	0	0	0	1	1	1	1	1	1	1	1	1	0
	BLUE (1023)	0	0	0	0	0	0	0	0	0	0	0	0	0	0	0	0	0	0	0	0	1	1	1	1	1	1	1	1	1	1

3-6. Power Sequence

3-6-1. Power Sequence

Panel Power Sequence: Power-up to BL_ON activation

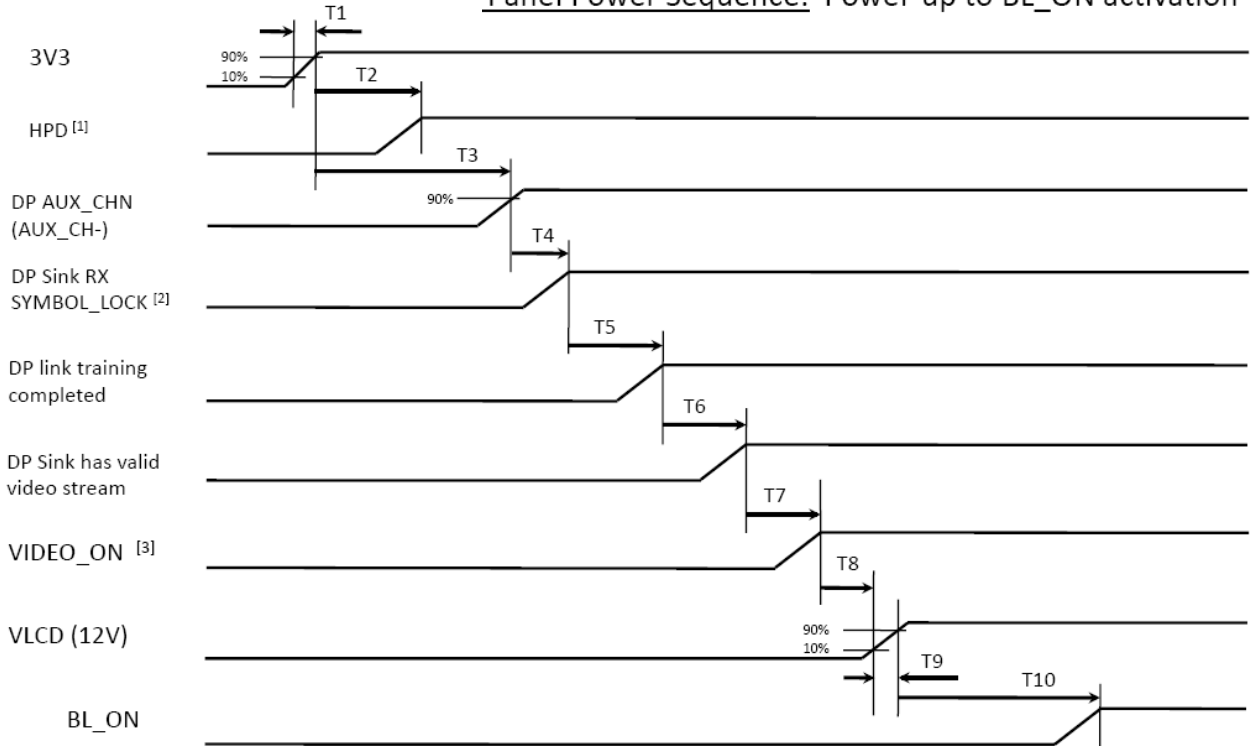

Parameter	Min	Max	Units
T1	0.5	10	ms
T2	0	-	ms
T3	-	-	ms
T4	0	-	ms
T5	0	-	ms

Parameter	Min	Max	Units
T6	0	-	ms
T7	0	200	ms
T8	0	200	ms
T9	0.4	10	ms
T10	200	-	ms

- Notes :
- [1] HPD is asserted high by Sink at power-up
 - [2] SYMBOL_LOCK indicated by contents of Sink DPCD registers 00202h to 00205h
 - [3] VIDEO_ON asserted high by Sink when video to panel is valid

- Notes :
1. Please avoid floating state of interface signal at invalid period.
 2. When the interface signal is invalid, be sure to pull down the power supply for LCD V_{LCD} to 0V.
 3. LED power must be turn on after power supply for LCD and interface signal are valid.

3-6. Power Sequence

3-6-1. Power Sequence

Panel Power Sequence: BL_ON de-activation

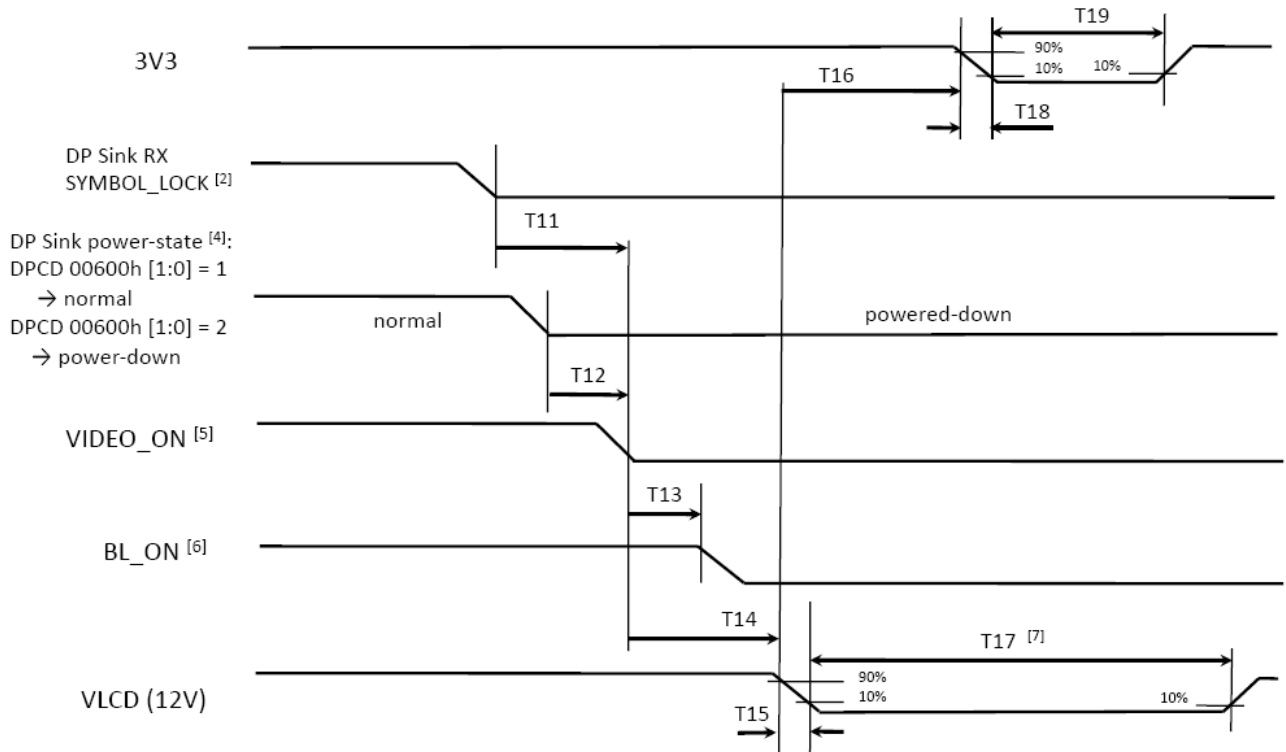

Parameter	Min	Max	Units
T11	0	10	ms
T12	0	5	ms
T13	-	10	ms
T14	10	100	ms
T15	0.01	1000	ms

Parameter	Min	Max	Units
T16	0	-	ms
T17	250	-	ms
T18	0.01	1000	ms
T19	150	-	ms

Notes : [2] SYMBOL_LOCK indicated by contents of Sink DPCD registers 00202h to 00205h

[4] Power-state set by Source in Sink DPCD register 00600h

[5] VIDEO_ON asserted low by Sink because of :

- 1) loss of SYMBOL_LOCK or
- 2) DP Sink is powered down

[6] BL_ON must be asserted low by system as rapidly as possible when video is invalid to avoid visible artifacts

[7] T17 always > T19

[8] min. times of 0 indicate precedence ordering of events, e.g. where actual timing is TBD

Product Specification
4. Optical Specifications

Optical characteristics are determined after the unit has been 'ON' for approximately 70 minutes in a dark environment at $25 \pm 2^\circ\text{C}$. The values specified are at an approximate distance 50cm from the LCD surface at a viewing angle of Φ and θ equal to 0° and aperture 1 degree.

FIG. 1 presents additional information concerning the measurement equipment and method.

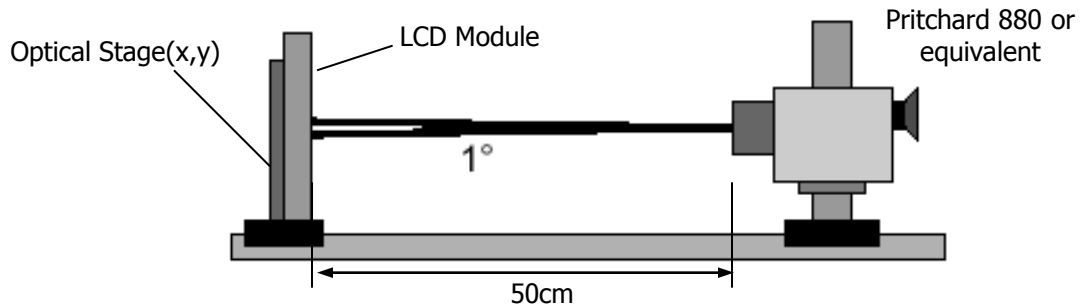
FIG. 1 Optical Characteristic Measurement Equipment and Method
Table 9. OPTICAL CHARACTERISTICS
 $(T_a=25^\circ\text{C}, V_{\text{LCD}}=12.0\text{V}, f_v=60\text{Hz Dclk}=242.28\text{MHz})$

Parameter	Symbol	Values			Units	Notes	
		Min	Typ	Max			
Contrast Ratio	CR	700	1000	-		1	
Surface Luminance, white	L_{WH}	300	380	-	cd/m ²	2	
Luminance Variation	δ_{WHITE}	75			%	3	
Response Time	Rise Time	T_{rR}	-	6.5	14	ms	4.1
	Decay Time	T_{rD}	-	7.5	14	ms	4.1
Color Coordinates [CIE1931]	RED	R_x		0.652			
		R_y		0.334			
	GREEN	G_x		0.304			
		G_y	Typ	0.619	Typ		
	BLUE	B_x	-0.03	0.148	+0.03		
		B_y		0.049			
	WHITE	W_x		0.313			
	W_y		0.329				
Color Shift	Horizontal	θ_{CST_H}	-	178	-	Degree	5
	Vertical	θ_{CST_V}	-	178	-		
Viewing Angle (CR>10)							
General	Horizontal	θ_H	170	178	-	Degree	6
	Vertical	θ_V	170	178	-		
Effective	Horizontal	θ_{GMA_H}		178	-	Degree	7
	Vertical	θ_{GMA_V}		178	-		
Gray Scale				2.2			8

Product Specification

Notes 1. Contrast Ratio(CR) is defined mathematically as :

$$\text{Contrast Ratio} = \frac{\text{Surface Luminance with all white pixels}}{\text{Surface Luminance with all black pixels}}$$

It is measured at center point(Location P1)

2. Surface luminance(L_{WH}) is luminance value at center 1 point(1) across the LCD surface 50cm from the surface with all pixels displaying white. For more information see FIG 2.
3. The variation in surface luminance , δ WHITE is defined as :

$$\delta_{WHITE} = \frac{\text{Minimum}(L_{P1}, L_{P2}, \dots, L_{P9})}{\text{Maximum}(L_{P1}, L_{P2}, \dots, L_{P9})} \times 100$$

Where L1 to L9 are the luminance with all pixels displaying white at 9 locations.
 For more information see FIG 2.

4. Response time is the time required for the display to transition from black to white (Rise Time, Tr_R) and from white to black (Decay Time, Tr_D). For additional information see FIG 3
5. Color shift is the angle at which the color difference is lower than 0.04.
 For more information see FIG 4.
 - Color difference ($\Delta u'v'$)

$$u' = \frac{4x}{-2x + 12y + 3} \quad v' = \frac{9y}{-2x + 12y + 3}$$

$$\Delta u'v' = \sqrt{(u'_1 - u'_2)^2 + (v'_1 - v'_2)^2}$$

u'_1, v'_1 : $u'v'$ value at viewing angle direction
 u'_2, v'_2 : $u'v'$ value at front ($\theta=0$)

- Pattern size : 25% Box size
- Viewing angle direction of color shift : Horizontal, Vertical

6. Viewing angle is the angle at which the contrast ratio is greater than 10. The angles are determined for the horizontal or x axis and the vertical or y axis with respect to the z axis which is normal to the LCD surface. For more information see FIG 5.
7. Effective viewing angle is the angle at which the gamma shift of gray scale is lower than 0.3.
 For more information see FIG 6 and FIG 7.
8. Gray scale specification
 Gamma Value is approximately 2.2. For more information see Table 10.

Product Specification

Measuring point for surface luminance & measuring point for luminance variation.

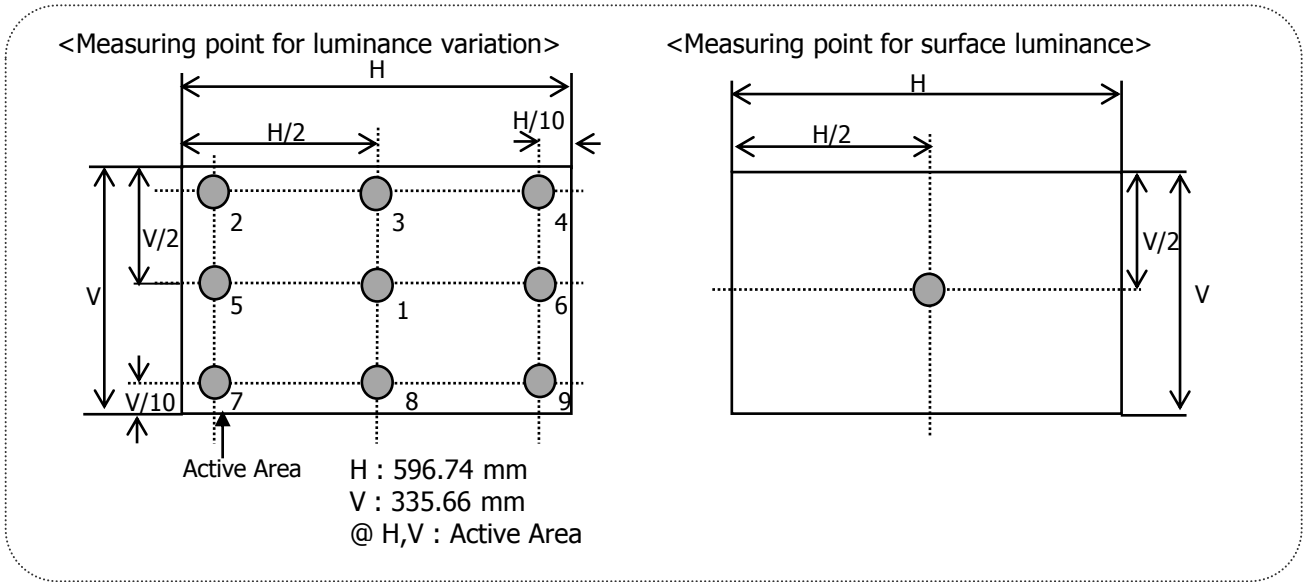

FIG. 2 Measure Point for Luminance

The response time is defined as the following figure and shall be measured by switching the input signal for "black" and "white".

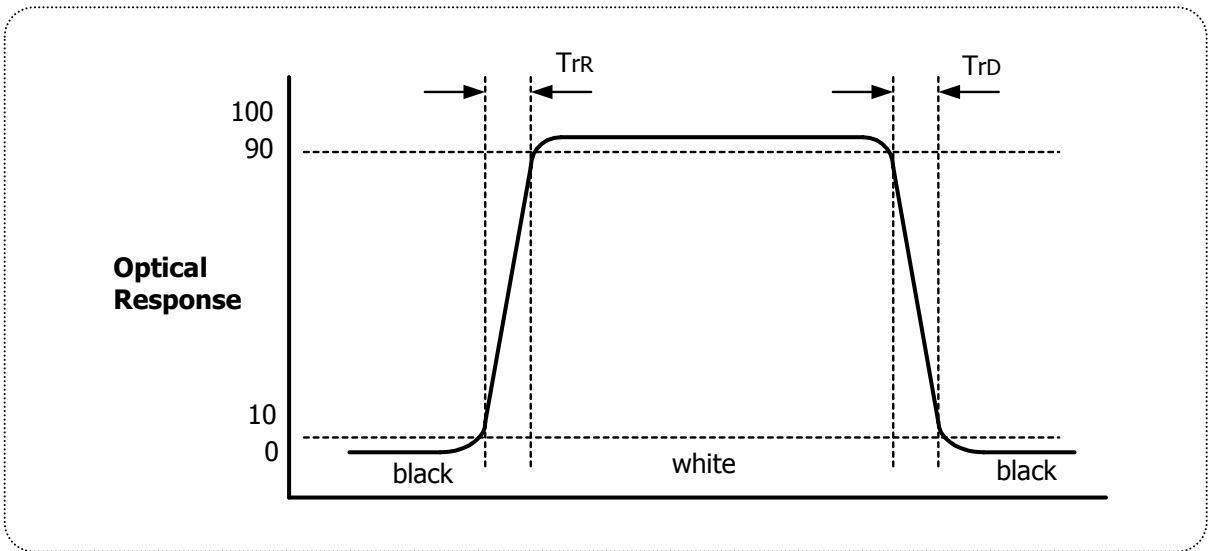

FIG. 3. Response Time

Product Specification

Color shift is defined as the following test pattern and color.

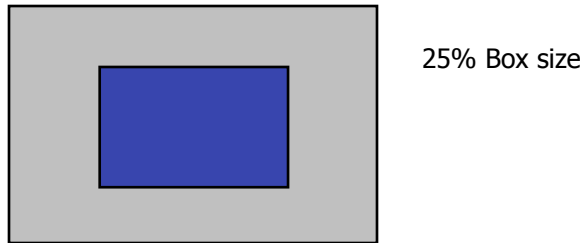

FIG. 4 Test Pattern

Average RGB values in Bruce RGB for Macbeth Chart

	Dark skin	Light skin	Blue sky	Foliage	Blue flower	Bluish green
R	98	206	85	77	129	114
G	56	142	112	102	118	199
B	45	123	161	46	185	178
	Orange	Purplish blue	Moderate red	Purple	Yellow green	Orange yellow
R	219	56	211	76	160	230
G	104	69	67	39	193	162
B	24	174	87	86	58	29
	Blue	Green	Red	Yellow	Magenta	cyan
R	26	72	197	241	207	35
G	32	148	27	212	62	126
B	145	65	37	36	151	172
	White	Neutral 8	Neutral 6.5	Neutral 5	Neutral 3.5	black
R	240	206	155	110	63	22
G	240	206	155	110	63	22
B	240	206	155	110	63	22

Product Specification

Dimension of viewing angle range.

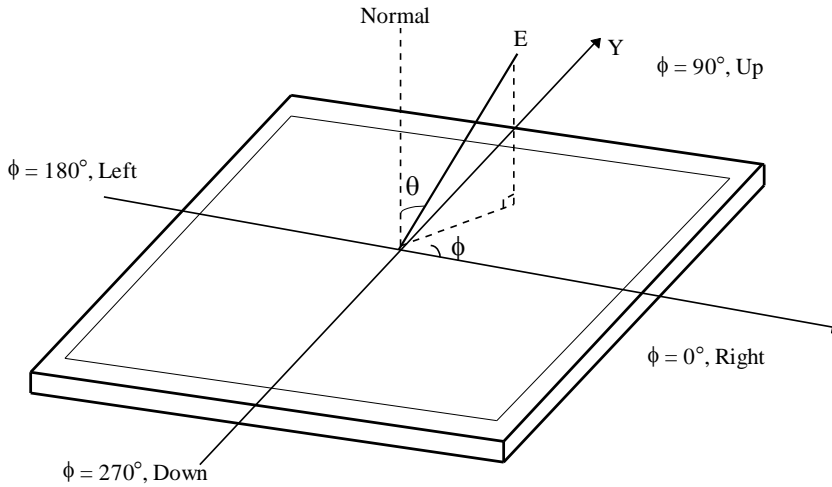

FIG. 5 Viewing angle

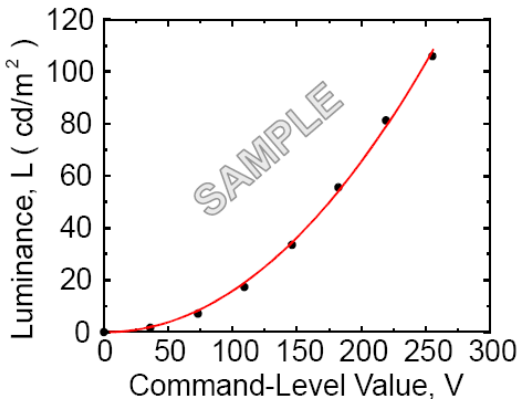

FIG. 6 Sample Luminance vs. gray scale (using a 256 bit gray scale)

$$L = aV^r + L_b$$

Here the Parameter a and γ relate the signal level V to the luminance L.
The GAMMA we calculate from the log-log representation (FIG. 7)

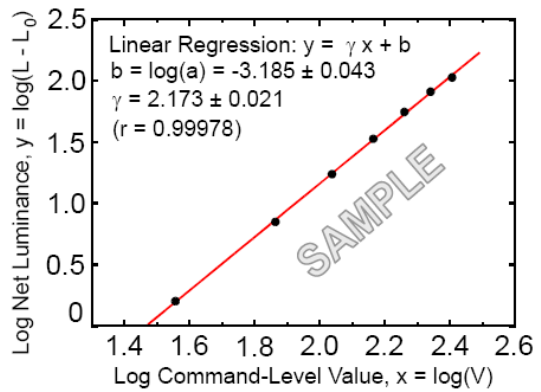

FIG. 7 Sample Log-log plot of luminance vs. gray scale

$$\log(L - L_b) = r \log(V) + \log(a)$$

Product Specification

Table 10. Gray Scale Specification

Gray Level	Relative Luminance [%] (Typ.)
0	0.10
31	1.08
63	4.71
95	11.5
127	21.7
159	35.5
191	53.1
223	74.5
255	100

Product Specification

5. Mechanical Characteristics

The contents provide general mechanical characteristics. In addition the figures in the next page are detailed mechanical drawing of the LCD.

Outline Dimension	Horizontal	630.0mm
	Vertical	376.13mm
	Depth	21.8mm
Bezel Area	Horizontal	601.7mm
	Vertical	340.7mm
Active Display Area	Horizontal	596.74mm
	Vertical	335.66mm
Weight	4,600g(Typ.)	
Surface Treatment	Hard coating(3H) Anti-glare treatment of the front polarizer	

Notes : Please refer to a mechanic drawing in terms of tolerance at the next page.

Product Specification

<FRONT VIEW>

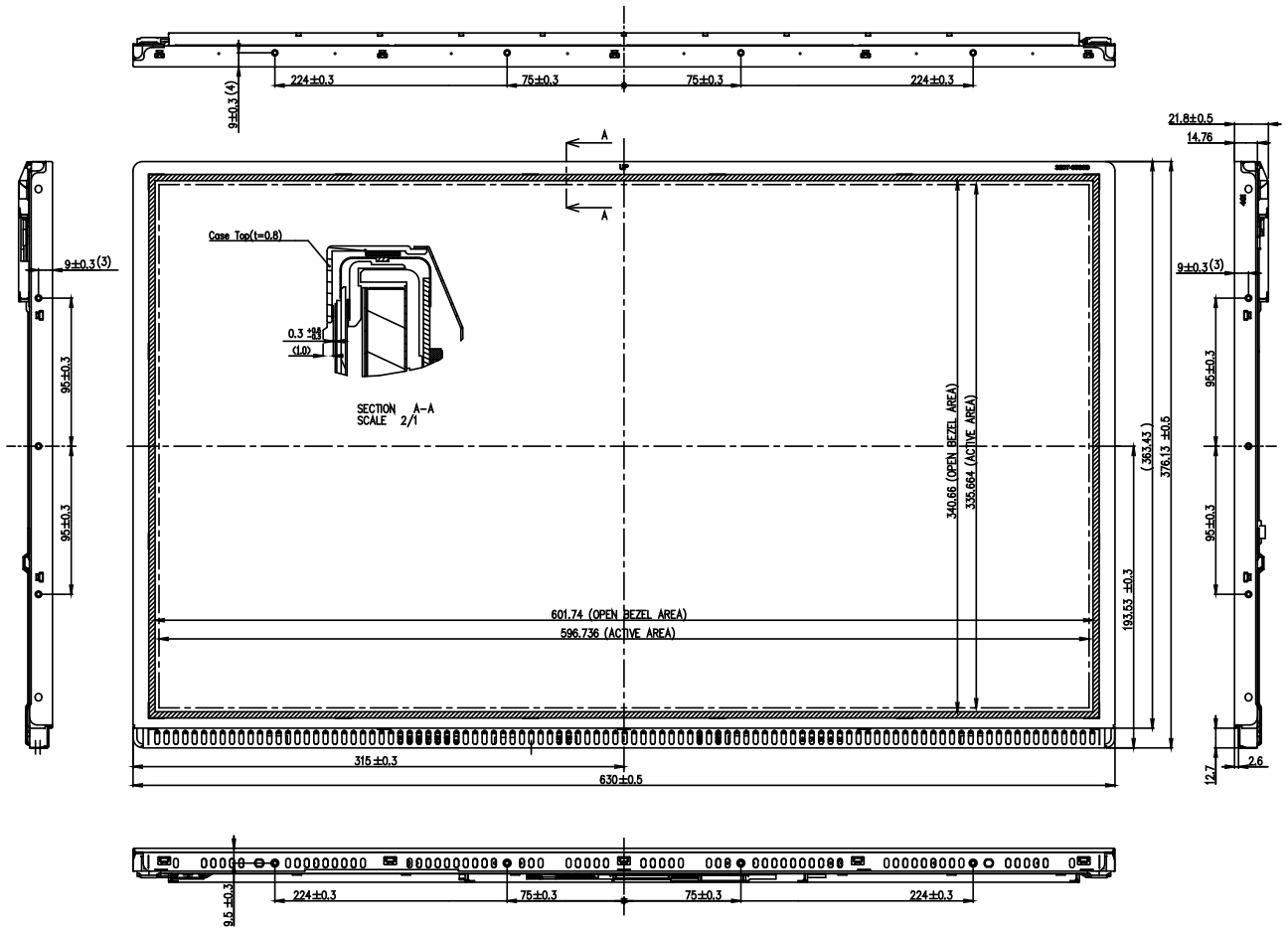

Product Specification

<REAR VIEW>

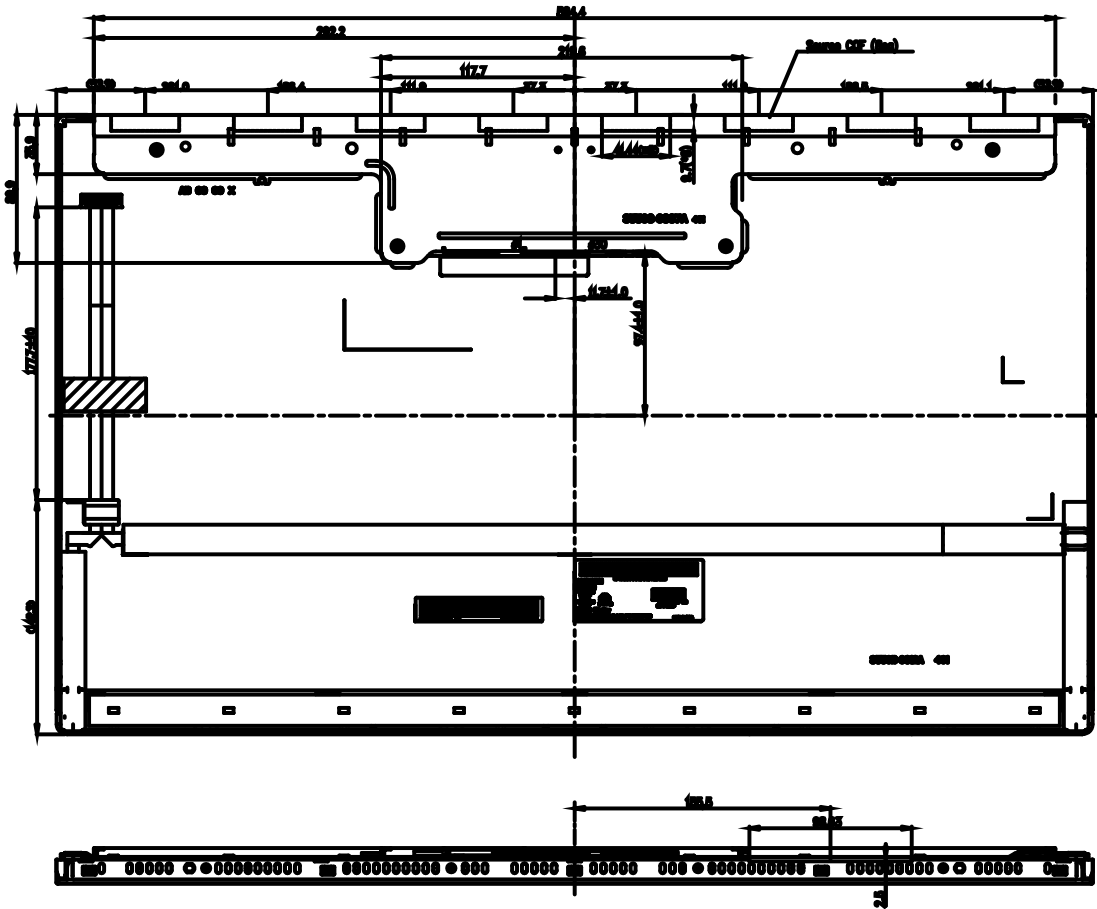

Note
 1. Unspecified tolerances are to be ±0.1mm.
 2. DR and partial disposition tolerance of display area are as following.
 (1) X-direction : $0-H \leq 1.0mm$
 (2) Y-direction : $0-H \leq 1.0mm$

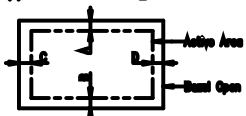

3. Target SPEC of Mounting : 6.0 - 7.0mm on VED (Active Area) (0.5 Pitch)
 4. V/F Connector Specification : 2000V-700mA (manufactured by I-PEX) or Compatible.
 5. LED Connector Specification : 1600K-300mA-120 (manufactured by EMI) or Compatible

Product Specification
6. Reliability

Environment test condition

No	Test Item	Condition
1	High temperature storage test	Ta= 60°C 240hrs
2	Low temperature storage test	Ta= -20°C 240hrs
3	High temperature operation test	Ta= 50°C 50%RH 240hrs
4	Low temperature operation test	Ta= 0°C 240hrs
5	Vibration test (non-operating)	Wave form : random Vibration level : 1.0G RMS Bandwidth : 10-300Hz Duration : X,Y,Z, 10 min One time each direction
6	Shock test (non-operating)	Shock level : 100Grms Waveform : half sine wave, 2ms Direction : ±X, ±Y, ±Z One time each direction
7	Altitude Operating Storage / Shipment	0 - 10,000 feet(3,048m) 0 - 40,000 feet(12,192m)

Product Specification**7. International Standards****7-1. Safety**

- a) UL 60950-1, Second Edition, Underwriters Laboratories Inc.
Information Technology Equipment - Safety - Part 1 : General Requirements.
- b) CAN/CSA C22.2 No.60950-1-07, Second Edition, Canadian Standards Association.
Information Technology Equipment - Safety - Part 1 : General Requirements.
- c) EN 60950-1:2006 + A11:2009, European Committee for Electrotechnical Standardization (CENELEC).
Information Technology Equipment - Safety - Part 1 : General Requirements.
- d) IEC 60950-1:2005, Second Edition, The International Electrotechnical Commission (IEC).
Information Technology Equipment - Safety - Part 1 : General Requirements.
(Including report of IEC60825-1:2001 clause 8 and clause 9)

Notes

- 1. Laser (LED Backlight) Information

Class 1M LED Product IEC60825-1 : 2001 Embedded LED Power (Class1M)

- 2. Caution
: LED inside.
Class 1M laser (LEDs) radiation when open.
Do not open while operating.

7-2. EMC

- a) ANSI C63.4-2003 "American National Standard for Methods of Measurement of Radio-Noise Emissions from Low-Voltage Electrical and Electronic Equipment in the Range of 9kHz to 40GHz." American National Standards Institute (ANSI), 2003.
- b) C.I.S.P.R. Pub. 22. Limits and methods of measurement of radio interference characteristics of information technology equipment." International Special Committee on Radio Interference (C.I.S.P.R.), 2005.
- c) EN 55022 "Limits and methods of measurement of radio interference characteristics of information technology equipment." European Committee for Electrotechnical Standardization (CENELEC), 2006.

7-3. Environment

- a) RoHS, Directive 2002/95/EC of the European Parliament and of the council of 27 January 2003

Product Specification

8. Packing

8-1. Designation of Lot Mark

a) Lot Mark

A	B	C	D	E	F	G	H	I	J	K	L	M
---	---	---	---	---	---	---	---	---	---	---	---	---

A,B,C : SIZE(INCH)

E : MONTH

D : YEAR

F ~ M : SERIAL NO.

Note

1. YEAR

Year	2011	2012	2013	2014	2015	2016	2017	2018	2019	2020
Mark	A	B	C	D	E	F	G	H	J	K

2. MONTH

Month	Jan	Feb	Mar	Apr	May	Jun	Jul	Aug	Sep	Oct	Nov	Dec
Mark	1	2	3	4	5	6	7	8	9	A	B	C

b) Location of Lot Mark

Serial No. is printed on the label. The label is attached to the backside of the LCD module.
This is subject to change without prior notice.

8-2. Packing Form

a) Package quantity in one box : 7ea

b) Box Size : 747mm X 335mm X 466mm

Product Specification

9. PRECAUTIONS

Please pay attention to the followings when you use this TFT LCD module.

9-1. MOUNTING PRECAUTIONS

- (1) You must mount a module using holes arranged in four corners or four sides.
- (2) You should consider the mounting structure so that uneven force (ex. Twisted stress) is not applied to the module. And the case on which a module is mounted should have sufficient strength so that external force is not transmitted directly to the module.
- (3) Please attach the surface transparent protective plate to the surface in order to protect the polarizer. Transparent protective plate should have sufficient strength in order to resist external force.
- (4) You should adopt radiation structure to satisfy the temperature specification.
- (5) Acetic acid type and chlorine type materials for the cover case are not desirable because the former generates corrosive gas of attacking the polarizer at high temperature and the latter causes circuit break by electro-chemical reaction.
- (6) Do not touch, push or rub the exposed polarizers with glass, tweezers or anything harder than HB pencil lead. And please do not rub with dust clothes with chemical treatment. Do not touch the surface of polarizer for bare hand or greasy cloth. (Some cosmetics are detrimental to the polarizer.)
- (7) When the surface becomes dusty, please wipe gently with absorbent cotton or other soft materials like chamois soaks with petroleum benzene. Normal-hexane is recommended for cleaning the adhesives used to attach front / rear polarizers. Do not use acetone, toluene and alcohol because they cause chemical damage to the polarizer.
- (8) Wipe off saliva or water drops as soon as possible. Their long time contact with polarizer causes deformations and color fading.
- (9) Do not open the case because inside circuits do not have sufficient strength.
- (10) As The IPS panel is sensitive & slim, please recommend the metal frame of the system supports the panel by the double side-mount.

9-2. OPERATING PRECAUTIONS

- (1) The spike noise causes the miss-operation of circuits. It should be lower than following voltage :
 $V = \pm 200\text{mV}$ (Over and under shoot voltage)
- (2) Response time depends on the temperature. (In lower temperature, it becomes longer.)
- (3) Brightness depends on the temperature. (In higher temperature, it becomes lower.)
 And in lower temperature, response time (required time that brightness is stable after turned on) becomes longer.
- (4) Be careful for condensation at sudden temperature change. Condensation makes damage to polarizer or electrical contacted parts. And after fading condensation, smear or spot will occur.
- (5) When fixed patterns are displayed for a long time, remnant image is likely to occur.
- (6) Module has high frequency circuits. Sufficient suppression to the electromagnetic interference shall be done by system manufacturers. Grounding and shielding methods may be important to minimize the interference.
- (7) Please do not give any mechanical and/or acoustical impact to LCM. Otherwise, LCM can't be operated its full characteristics perfectly.
- (8) A screw which is fastened up the steels should be a machine screw.
 (if not, it causes metallic foreign material and deal LCM a fatal blow)
- (9) Please do not set LCD on its edge.
- (10) When LCMs are used for public display defects such as Yogore, image sticking can not be guaranteed.

Product Specification**9-3. ELECTROSTATIC DISCHARGE CONTROL**

Since a module is composed of electronic circuits, it is not strong to electrostatic discharge. Make certain that treatment persons are connected to ground through wrist band etc. And don't touch interface pin directly.

9-4. PRECAUTIONS FOR STRONG LIGHT EXPOSURE

Strong light exposure causes degradation of polarizer and color filter.

9-5. STORAGE

When storing modules as spares for a long time, the following precautions are necessary.

- (1) Store them in a dark place. Do not expose the module to sunlight or fluorescent light. Keep the temperature between 5°C and 35°C at normal humidity.
- (2) The polarizer surface should not come in contact with any other object.
It is recommended that they be stored in the container in which they were shipped.

9-6. HANDLING PRECAUTIONS FOR PROTECTION FILM

- (1) The protection film is attached to the bezel with a small masking tape.
When the protection film is peeled off, static electricity is generated between the film and polarizer.
This should be peeled off slowly and carefully by people who are electrically grounded and with well ion-blown equipment or in such a condition, etc.
- (2) When the module with protection film attached is stored for a long time, sometimes there remains a very small amount of glue still on the bezel after the protection film is peeled off.
- (3) You can remove the glue easily. When the glue remains on the bezel surface or its vestige is recognized, please wipe them off with absorbent cotton waste or other soft material like chamois soaked with normal-hexane.