

LM2772

Low-Ripple Switched Capacitor Step-Down Regulator

General Description

The LM2772 is a switched capacitor step-down regulator that produces a 1.2V output. It is capable of supplying loads up to 150mA with 3% output voltage regulation over line, load, and temperature. The LM2772 operates with an input voltage from 3.0V to 5.5V, accommodating 1-cell Li-Ion batteries and chargers.

The LM2772 utilizes a highly efficient regulated multi-gain charge pump. Pre-regulated 1.1MHz fixed-frequency switching results in very low ripple and noise on both the input and the output. When output currents are low, the part automatically switches to a low-ripple PFM regulation mode to maintain high efficiency over the entire load range.

The LM2772 is available in National's 10-pad Leadless Lead-frame No-Pullback Package (LLP-10).

Features

- Low-Noise Fixed Frequency Operation
- 1.2V Output Voltage
- 3% Output Voltage Regulation
- Li-Ion (3.6V) to 1.2V with 80% Efficiency
- Very Low Output Ripple: 8mV @ 150mA
- Output Currents up to 150mA
- 2.7V to 5.5V Input Voltage Range
- Shutdown Disconnects Load from V_{IN}
- 1.1MHz Switching Frequency
- No Inductors...Small Solution Size
- Short Circuit and Thermal Protection
- LLP-10 Package (3mm × 3mm × 0.8mm)

Applications

- DSP, Memory, and Microprocessor Power Supplies
- Mobile Phones and Pagers
- Portable Electronic Devices

Typical Application Circuit

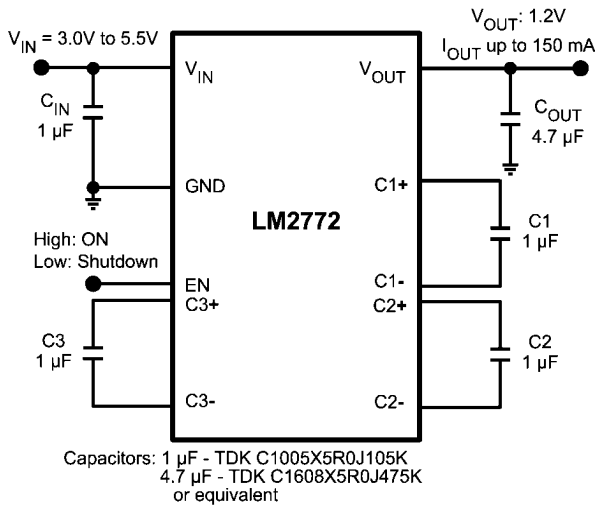

20216401

LM2772 Efficiency vs. Low-Dropout Linear Regulator (LDO) Efficiency

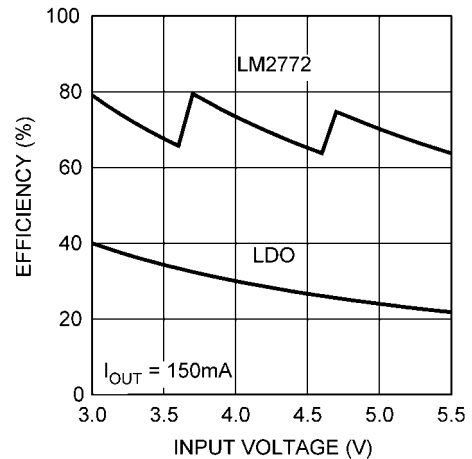

20216413

Connection Diagram and Package Mark Information

10-Pin Non-Pullback Leadless Frame Package (LLP-10) National Semiconductor Package Number SDA10A

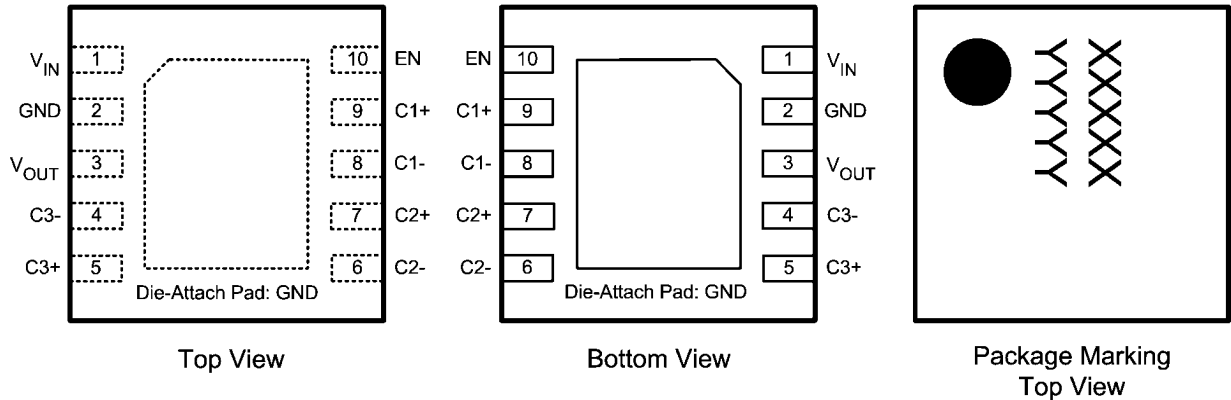

Note: The actual physical placement of the package marking will vary from part to part. The package marking placeholder “XXXXX” is a code for die traceability. “YYYYY” identifies the device (part number, voltage option, etc.). See the Order Information table below for the device ID codes.

20216402

Pin Descriptions

Pin #	Name	Description
1	V_{IN}	Input Voltage: Recommended V_{IN} operating range 3.0V to 5.5V.
2	GND	Ground
3	V_{OUT}	Output Voltage
4	C3-	Flying Capacitor 3: Negative Terminal
5	C3+	Flying Capacitor 3: Positive Terminal
6	C2-	Flying Capacitor 2: Negative Terminal
7	C2+	Flying Capacitor 2: Positive Terminal
8	C1-	Flying Capacitor 1: Negative Terminal
9	C1+	Flying Capacitor 1: Positive Terminal
10	EN	Enable Pin Logic Input. Applying a logic HIGH voltage signal enables the part. A logic LOW voltage signal places the the device in shutdown.

Order Information

Output Voltages	Order Number	Package Mark ID	Package	Supplied as:
1.2V	LM2772SD	XXXXX = $\phi Z\phi 2\phi X$ YYYYY = L2772	SDA10A Non-Pullback LLP	1000 Units, Tape and Reel
1.2V	LM2772SDX	XXXXX = $\phi Z\phi 2\phi X$ YYYYY = L2772		4500 Units, Tape and Reel

Absolute Maximum Ratings (Notes 1, 2)

If Military/Aerospace specified devices are required, please contact the National Semiconductor Sales Office/Distributors for availability and specifications.

V_{IN} Pin Voltage	-0.3V to 6.0V
EN Pin Voltage	-0.3V to ($V_{IN}+0.3V$) w/ 6.0V max
Continuous Power Dissipation (Note 3)	Internally Limited
Junction Temperature (T_{J-MAX})	150°C
Storage Temperature Range	-65°C to +150°C
Maximum Lead Temperature (Note 4)	265°C
ESD Rating (Note 5) Human Body Model:	2.0kV

Operating Ratings (Notes 1, 2)

Input Voltage Range	2.7V to 5.5V
Recommended Load Current Range	0mA to 150mA
Junction Temperature (T_J) Range	-30°C to +110°C
Ambient Temperature (T_A) Range (Note 6)	-30°C to +85°C

Thermal Properties

Junction-to-Ambient Thermal Resistance (θ_{JA}), LLP10 Package (Note 7)	55°C/W
----------------------------------------------------------------------------------	--------

Electrical Characteristics (Notes 2, 8)

Limits in standard typeface are for $T_J = 25^\circ\text{C}$. Limits in **boldface** type apply over the full operating junction temperature range (-30°C $\leq T_J \leq +110^\circ\text{C}$). Unless otherwise noted, specifications apply to the LM2772 Typical Application Circuit (pg. 1) with: $V_{IN} = 3.6V$; $V(EN) = 1.8V$, $C_{IN} = C_1 = C_2 = C_3 = 1.0\mu\text{F}$, $C_{OUT} = 4.7\mu\text{F}$. (Note 9)

Symbol	Parameter	Condition	Min	Typ	Max	Units
V_{OUT}	1.2V Output Voltage Regulation	$3.0V \leq V_{IN} \leq 5.5V$ $0mA \leq I_{OUT} \leq 150mA$	1.164 (-3%)	1.2	1.236 (+3%)	V
		$0mA \leq I_{OUT} \leq 150mA$	1.178 (-1.8%)	1.2	1.236 (+3.0%)	
V_{OUT}/I_{OUT}	Output Load Regulation	$0mA \leq I_{OUT} \leq 150mA$		0.15		mV/mA
V_{OUT}/V_{IN}	Output Line Regulation			0.2		%/V
E	Power Efficiency	$I_{OUT} = 150mA$		80		%
I_Q	Quiescent Supply Current	$I_{OUT} = 0mA$ (Note 10)		47	50	μA
V_R	Fixed Frequency Output Ripple	$40mA \leq I_{OUT} \leq 150mA$		8		mV
V_{R-PFM}	PFM-Mode Output Ripple	$I_{OUT} < 40mA$		12		mV
I_{SD}	Shutdown Current	$V(EN) = 0V$		0.01	0.3	μA
F_{SW}	Switching Frequency	$3.0V \leq V_{IN} \leq 5.5V$	0.80	1.15	1.50	MHz
I_{CL}	Output Current Limit	$V_{IN} = 5.5V$ $0V \leq V_{OUT} \leq 0.2V$		500		mA
t_{ON}	Turn-on Time			150		μs
V_{IL}	Logic-low Input Voltage	$3.0V \leq V_{IN} \leq 5.5V$	0		0.63	V
V_{IH}	Logic-high Input Voltage	$3.0V \leq V_{IN} \leq 5.5V$	1.1		V_{IN}	V
I_{IH}	Logic-high Input Current	$V(EN) = 1.8V$ (Note 11)		5		μA
I_{IL}	Logic-low Input Current	Logic Input = 0V		0.01		μA

Note 1: Absolute Maximum Ratings indicate limits beyond which damage to the component may occur. Operating Ratings are conditions under which operation of the device is guaranteed. Operating Ratings do not imply guaranteed performance limits. For guaranteed performance limits and associated test conditions, see the Electrical Characteristics tables.

Note 2: All voltages are with respect to the potential at the GND pins.

Note 3: Internal thermal shutdown circuitry protects the device from permanent damage. Thermal shutdown engages at $T_J=150^\circ\text{C}$ (typ.) and disengages at $T_J=140^\circ\text{C}$ (typ.).

Note 4: For detailed information on soldering requirements and recommendations, please refer to National Semiconductor's **Application Note 1187 (AN-1187): Leadless Leadframe Package (LLP)**.

Note 5: The Human body model is a 100pF capacitor discharged through a 1.5k Ω resistor into each pin. MIL-STD-883 3015.7

Note 6: Maximum ambient temperature (T_{A-MAX}) is dependent on the maximum operating junction temperature ($T_{J-MAX-OP} = 110^\circ\text{C}$), the maximum power dissipation of the device in the application (P_{D-MAX}), and the junction-to ambient thermal resistance of the part/package in the application (θ_{JA}), as given by the following equation: $T_{A-MAX} = T_{J-MAX-OP} - (\theta_{JA} \times P_{D-MAX})$.

Note 7: Junction-to-ambient thermal resistance is highly application and board-layout dependent. In applications where high maximum power dissipation exists, special care must be paid to thermal dissipation issues.

Note 8: Min and Max limits are guaranteed by design, test, or statistical analysis. Typical numbers are not guaranteed, but do represent the most likely norm.

Note 9: C_{IN} , C_{OUT} , C_1 , C_2 , C_3 : Low-ESR Surface-Mount Ceramic Capacitors (MLCCs) used in setting electrical characteristics.

Note 10: V_{OUT} is set to 1.3V during this test (Device is not switching).

Note 11: There is a 350k Ω pull-down resistor connected internally between the EN pin and GND.

Block Diagram

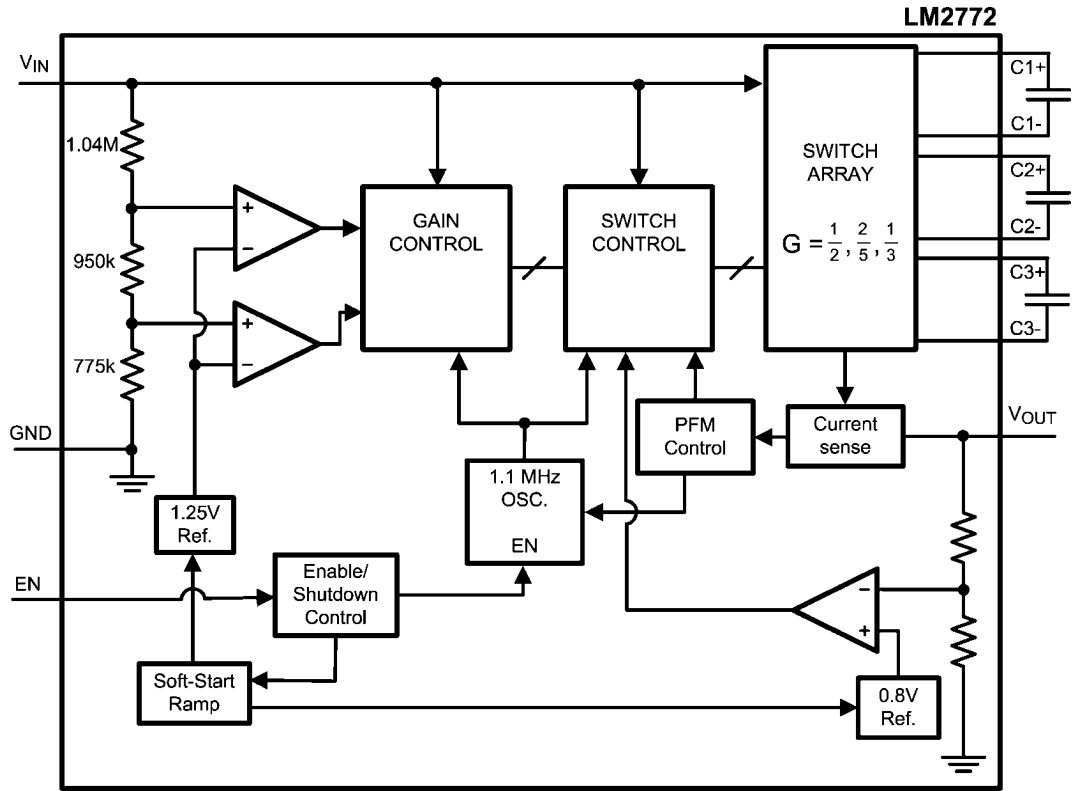

20216403

Typical Performance Characteristics Unless otherwise specified: $V_{IN} = 3.6V$, $C_{IN} = C_1 = C_2 = C_3 = 1.0\mu F$, $C_{OUT} = 4.7\mu F$, $T_A = 25^\circ C$. Capacitors are low-ESR multi-layer ceramic capacitors (MLCC's).

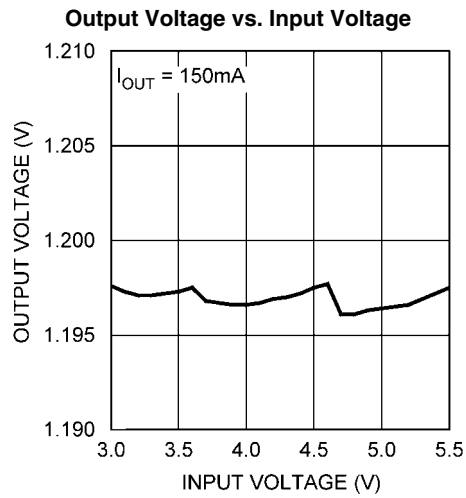

20216412

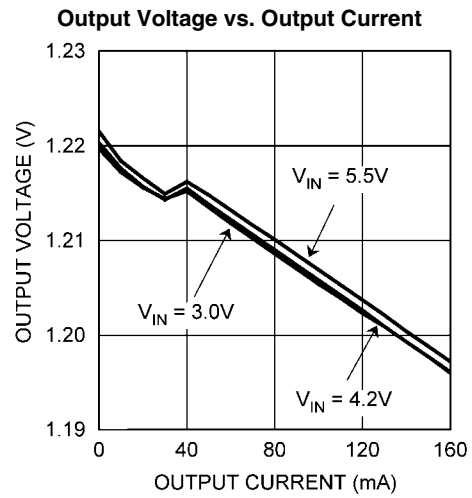

20216414

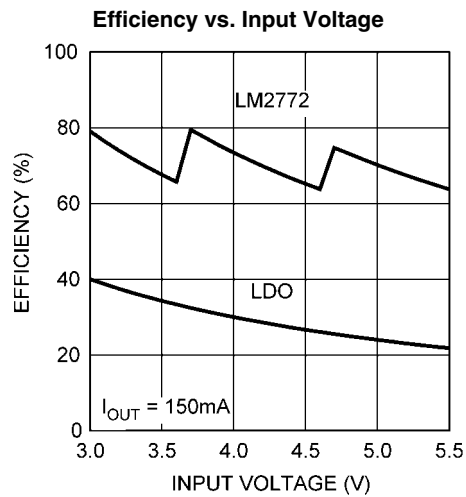

20216413

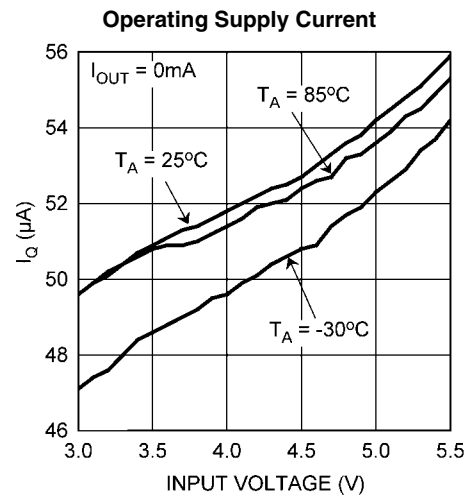

20216426

Input and Output Voltage Ripple, Load = 150mA

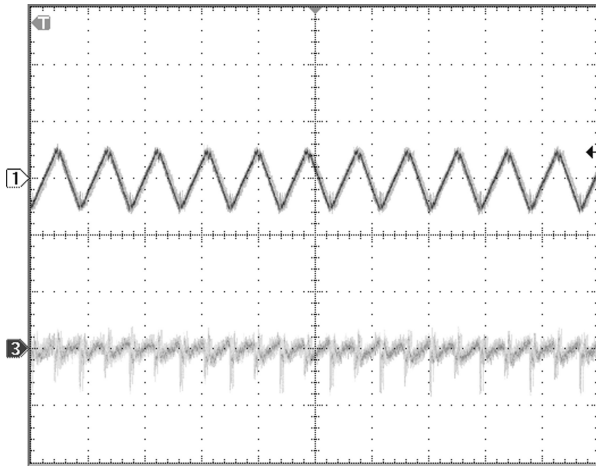

20216415

CH1: V_{IN} ; Scale: 50mV/Div, AC Coupled
 CH3: V_{OUT} ; Scale: 10mV/Div, AC Coupled
 Time scale: 1 μ s/Div

Load Step 10mA to 150mA, $V_{IN} = 3.6V$

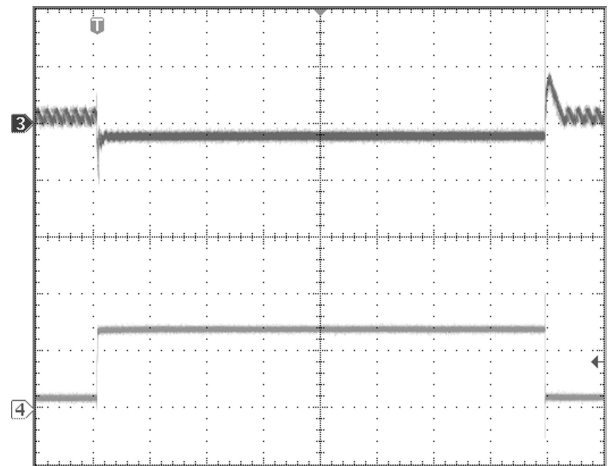

20216423

CH3: V_{OUT} ; Scale: 50mV/Div, AC Coupled
 CH4: I_{OUT} ; Scale: 100mA/Div
 Time scale: 40 μ s/Div

Load Step 10mA to 150mA, $V_{IN} = 4.7V$

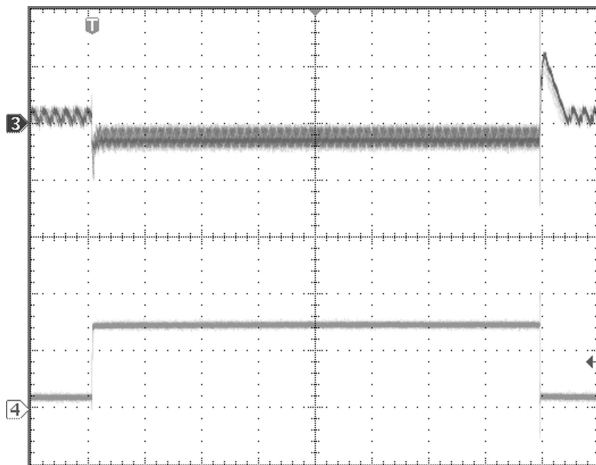

20216424

CH3: V_{OUT} ; Scale: 50mV/Div, AC Coupled
 CH4: I_{OUT} ; Scale: 100mA/Div
 Time scale: 40 μ s/Div

Line Step 3.5V to 4.0V with Load = 150mA

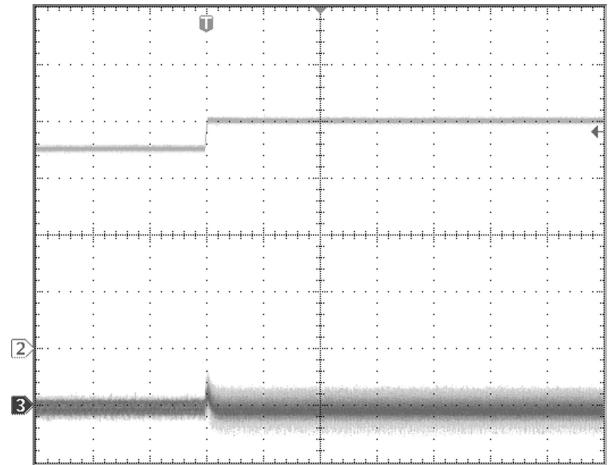

20216421

CH2: V_{IN} ; Scale: 1V/Div, DC Coupled
 CH3: V_{OUT} ; Scale: 20mV/Div, AC Coupled
 Time scale: 400 μ s/Div

Line Step 4.0V to 3.5V with Load = 150mA

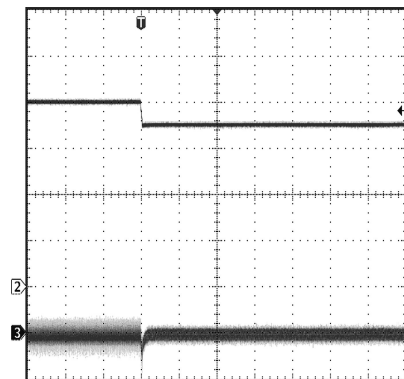

20216422

CH2: V_{IN} ; Scale: 1V/Div, DC Coupled
 CH3: V_{OUT} ; Scale: 20mV/Div, AC Coupled
 Time scale: 400 μ s/Div

Oscillator Frequency vs. Input Voltage

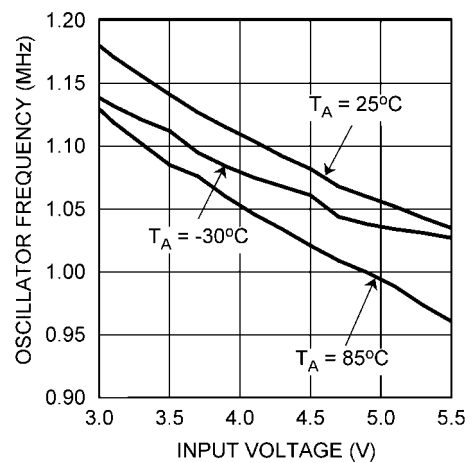

20216425

Startup Behavior, Load = 150mA

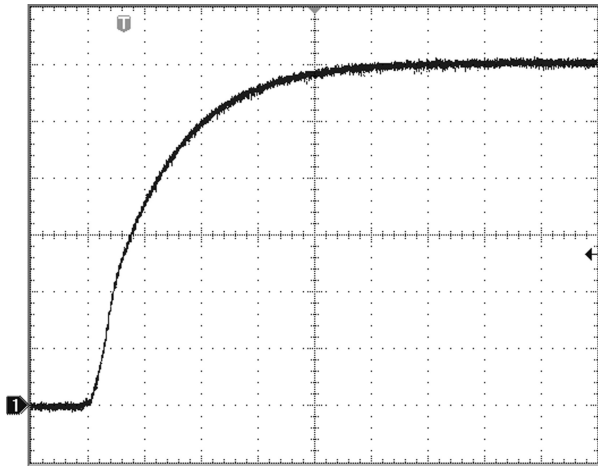

20216416

CH1: V_{OUT}; Scale: 200mV/Div, DC Coupled
Time scale: 20μs/Div

Operation Description

OVERVIEW

The LM2772 is a switched capacitor converter that produces a regulated, low voltage output. The core of the part is a highly efficient charge pump that utilizes fixed frequency pre-regulation and Pulse Frequency Modulation to minimize ripple and power losses over wide input voltage and output current ranges. A description of the principal operational characteristics of the LM2772 is detailed in the **Circuit Description**, and **Efficiency Performance** sections. These sections refer to details in the **Block Diagram**.

CIRCUIT DESCRIPTION

The core of the LM2772 is a two-phase charge pump controlled by an internally generated non-overlapping clock. The charge pump operates by using external flying capacitors C_1 , C_2 , and C_3 to transfer charge from the input to the output. At input voltages below 3.5V (typ.) the LM2772 operates in a 1/2x Gain, with the input current being equal to 1/2 of the load current. At input voltages between 3.5V to 4.6V(typ.) the part utilizes a gain of 2/5x, resulting in an input current equal to 2/5 times the load current. At input voltages above 4.6V (typ.), the part is in a gain of 1/3, with the input current being 1/3 of the load current.

The two phases of the switched capacitor switching cycle will be referred to as the "charge phase" and the "discharge phase". During the charge phase, the flying capacitor is charged by the input supply. After half of the switching cycle [$t = 1/(2 \times F_{SW})$], the LM2772 switches to the discharge phase. In this configuration, the charge that was stored on the flying capacitors in the charge phase is transferred to the output.

The LM2772 uses fixed frequency pre-regulation to regulate the output voltage to 1.2V during moderate to high load currents. The input and output connections of the flying capacitors are made with internal MOS switches. Pre-regulation limits the gate drive of the MOS switch connected between the voltage input and the flying capacitors. Controlling the on resistance of this switch limits the amount of charge transferred into and out of each flying capacitor during the charge and discharge phases, and in turn helps to keep the output ripple very low.

When output currents are low (<40mA typ.), the LM2772 automatically switches to a low-ripple Pulse Frequency Modulation (PFM) form of regulation. In PFM mode, the flying capacitors stay in the discharge phase until the output voltage drops below a predetermined trip point. When this occurs, the flying capacitors switch back to the charge phase. After being charged, the flying capacitors repeat the process of staying in the discharge phase and switching to the charge phase when necessary.

EFFICIENCY PERFORMANCE

Charge-pump efficiency is derived in the following two ideal equations (supply current and other losses are neglected for simplicity):

$$E = (V_{OUT} \times I_{OUT}) \div (V_{IN} \times I_{IN}) = V_{OUT} \div (G \times V_{IN})$$

In the equations, G represents the charge pump gain. Efficiency is at its highest as $G \times V_{IN}$ approaches V_{OUT} . Refer to the efficiency graph in the **Typical Performance Characteristics** section for detailed efficiency data. The transition between gains of 1/2, 2/5, and 1/3 are clearly distinguished by the sharp discontinuity in the efficiency curve.

SHUTDOWN

The LM2772 is in shutdown mode when the voltage on the enable pin (EN) is logic-low. In shutdown, the LM2772 draws virtually no supply current. When in shutdown, the output of the LM2772 is completely disconnected from the input. Internal feedback resistors pull the output voltage down to 0V during shutdown.

SOFT START

The LM2772 employs soft start circuitry to prevent excessive input inrush currents during startup. At startup, the output voltage gradually rises from 0V to the nominal output voltage. This occurs in 150 μ s (typ.). Soft-start is engaged when the part is enabled, including situations where voltage is established simultaneously on the V_{IN} and EN pins.

THERMAL SHUTDOWN

Protection from damage related to overheating is achieved with a thermal shutdown feature. When the junction temperature rises to 150°C (typ.), the part switches into shutdown mode. The LM2772 disengages thermal shutdown when the junction temperature of the part is reduced to 140°C (typ.). Due to the high efficiency of the LM2772, thermal shutdown and/or thermal cycling should not be encountered when the part is operated within specified input voltage, output current, and ambient temperature operating ratings. If thermal cycling is seen under these conditions, the most likely cause is an inadequate PCB layout that does not allow heat to be sufficiently dissipated out of the LLP package.

CURRENT LIMIT PROTECTION

The LM2772 charge pump contains current limit protection circuitry that protects the device during V_{OUT} fault conditions where excessive current is drawn. Output current is limited to 500mA (typ.).

Application Information

RECOMMENDED CAPACITOR TYPES

The LM2772 requires 5 external capacitors for proper operation. Surface-mount multi-layer ceramic capacitors are recommended. These capacitors are small, inexpensive and have very low equivalent series resistance (ESR, $\leq 15m\Omega$ typ.). Tantalum capacitors, OS-CON capacitors, and aluminum electrolytic capacitors generally are not recommended for use with the LM2772 due to their high ESR, as compared to ceramic capacitors.

For most applications, ceramic capacitors with an X7R or X5R temperature characteristic are preferred for use with the LM2772. These capacitors have tight capacitance tolerance (as good as $\pm 10\%$) and hold their value over temperature (X7R: $\pm 15\%$ over -55°C to 125°C ; X5R: $\pm 15\%$ over -55°C to 85°C).

Capacitors with a Y5V or Z5U temperature characteristic are generally not recommended for use with the LM2772. These types of capacitors typically have wide capacitance tolerance (+80%, -20%) and vary significantly over temperature (Y5V: +22%, -82% over -30°C to $+85^\circ\text{C}$ range; Z5U: +22%, -56% over $+10^\circ\text{C}$ to $+85^\circ\text{C}$ range). Under some conditions, a 1 μ F-rated Y5V or Z5U capacitor could have a capacitance as low as 0.1 μ F. Such detrimental deviation is likely to cause Y5V and Z5U capacitors to fail to meet the minimum capacitance requirements of the LM2772.

Net capacitance of a ceramic capacitor decreases with increased DC bias. This degradation can result in lower capacitance than expected on the input and/or output, resulting in

higher ripple voltages and currents. Using capacitors at DC bias voltages significantly below the capacitor voltage rating will usually minimize DC bias effects. Consult capacitor manufacturers for information on capacitor DC bias characteristics.

Capacitance characteristics can vary quite dramatically with different application conditions, capacitor types, and capacitor manufacturers. It is strongly recommended that the LM2772 circuit be thoroughly evaluated early in the design-in process with the mass-production capacitors of choice. This will help ensure that any such variability in capacitance does not negatively impact circuit performance.

The table below lists some leading ceramic capacitor manufacturers.

Manufacturer	Contact Information
AVX	www.avx.com
Murata	www.murata.com
Taiyo-Yuden	www.t-yuden.com
TDK	www.component.tdk.com
Vishay-Vitramon	www.vishay.com

OUTPUT CAPACITOR AND OUTPUT VOLTAGE RIPPLE

The output capacitor in the LM2772 circuit (C_{OUT}) directly impacts the magnitude of output voltage ripple. Other prominent factors also affecting output voltage ripple include input voltage, output current and flying capacitance. Due to the complexity of the regulation topology, providing equations or models to approximate the magnitude of the ripple can not be easily accomplished. But one important generalization can be made: increasing (decreasing) the output capacitance will result in a proportional decrease (increase) in output voltage ripple.

In typical high-current applications, a 4.7 μ F low-ESR ceramic output capacitor is recommended. Different output capacitance values can be used to reduce ripple, shrink the solution size, and/or cut the cost of the solution. But changing the output capacitor may also require changing the flying capacitor and/or input capacitor to maintain good overall circuit performance. Performance of the LM2772 with different capacitor setups is discussed in the section **Recommended Capacitor Configurations**.

High ESR in the output capacitor increases output voltage ripple. If a ceramic capacitor is used at the output, this is usually not a concern because the ESR of a ceramic capacitor is typically very low and has only a minimal impact on ripple magnitudes. If a different capacitor type with higher ESR is used (tantalum, for example), the ESR could result in high ripple. To eliminate this effect, the net output ESR can be significantly reduced by placing a low-ESR ceramic capacitor in parallel with the primary output capacitor. The low ESR of the ceramic capacitor will be in parallel with the higher ESR, resulting in a low net ESR based on the principles of parallel resistance reduction.

INPUT CAPACITOR AND INPUT VOLTAGE RIPPLE

The input capacitor (C_{IN}) is a reservoir of charge that aids a quick transfer of charge from the supply to the flying capacitors during the charge phase of operation. The input capacitor helps to keep the input voltage from drooping at the start of the charge phase when the flying capacitors are connected to the input. It also filters noise on the input pin, keeping this noise out of sensitive internal analog circuitry that is biased off the input line.

Much like the relationship between the output capacitance and output voltage ripple, input capacitance has a dominant and first-order effect on input ripple magnitude. Increasing (decreasing) the input capacitance will result in a proportional decrease (increase) in input voltage ripple. Input voltage, output current, and flying capacitance also will affect input ripple levels to some degree.

In typical high-current applications, a 1 μ F low-ESR ceramic capacitor is recommended on the input. Different input capacitance values can be used to reduce ripple, shrink the solution size, and/or cut the cost of the solution. But changing the input capacitor may also require changing the flying capacitor and/or output capacitor to maintain good overall circuit performance. Performance of the LM2772 with different capacitor setups is discussed below in **Recommended Capacitor Configurations**.

FLYING CAPACITORS

The flying capacitors (C_1 , C_2 , C_3) transfer charge from the input to the output. Flying capacitance can impact both output current capability and ripple magnitudes. If flying capacitance is too small, the LM2772 may not be able to regulate the output voltage when load currents are high. On the other hand, if the flying capacitance is too large, the flying capacitor might overwhelm the input and output capacitors, resulting in increased input and output ripple.

In typical high-current applications, 1 μ F low-ESR ceramic capacitors are recommended for the flying capacitors. Polarized capacitors (tantalum, aluminum electrolytic, etc.) must not be used for the flying capacitor, as they could become reverse-biased during LM2772 operation.

RECOMMENDED CAPACITOR CONFIGURATIONS

The data in *Table 1* can be used to assist in the selection of a capacitor configuration that best balances solution size and cost with the electrical requirements of the application.

As previously discussed, input and output ripple voltages will vary with output current and input voltage. The numbers provided show expected ripple voltage with $V_{IN} = 3.6V$ and a load current of 150mA. The table offers a first look at approximate ripple levels and provides a comparison of different capacitor configurations, but is not intended to be a guarantee of performance. With any capacitance configuration chosen, always verify that the performance of the ripple waveforms are suitable for the intended application. The same capacitance value must be used for all the flying capacitors.

TABLE 1. LM2772 Performance with Different Capacitor Configurations (Note 12)

CAPACITOR CONFIGURATION ($V_{IN} = 3.6V$)	TYPICAL INPUT RIPPLE	TYPICAL OUTPUT RIPPLE
$C_{IN} = 1\mu F$, $C_{OUT} = 4.7\mu F$, $C_1, C_2, C_3 = 1\mu F$	54mV	4mV
$C_{IN} = 1\mu F$, $C_{OUT} = 2.2\mu F$, $C_1, C_2, C_3 = 1\mu F$	48mV	6mV
$C_{IN} = 0.47\mu F$, $C_{OUT} = 4.7\mu F$, $C_1, C_2, C_3 = 1\mu F$	83mV	5mV
$C_{IN} = 0.47\mu F$, $C_{OUT} = 3.3\mu F$, $C_1, C_2, C_3 = 1\mu F$	82mV	4mV
$C_{IN} = 0.47\mu F$, $C_{OUT} = 3.3\mu F$, $C_1, C_2, C_3 = 0.47\mu F$	83mV	5mV

Note 12: Refer to the text in the Recommended Capacitor Configurations section for detailed information on the data in this table

Layout Guidelines

Proper board layout will help to ensure optimal performance of the LM2772 circuit. The following guidelines are recommended:

- Place capacitors as close to the LM2772 as possible, and preferably on the same side of the board as the IC.
- Use short, wide traces to connect the external capacitors to the LM2772 to minimize trace resistance and inductance.
- Use a low resistance connection between ground and the GND pin of the LM2772. Using wide traces and/or multiple vias to connect GND to a ground plane on the board is most advantageous.

Physical Dimensions inches (millimeters) unless otherwise noted

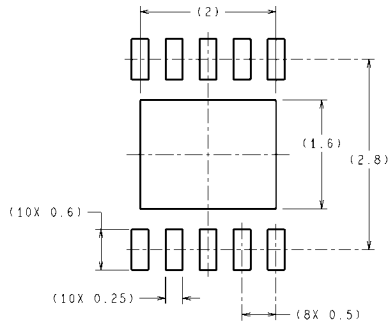

DIMENSIONS ARE IN MILLIMETERS
DIMENSIONS IN () FOR REFERENCE ONLY

RECOMMENDED LAND PATTERN

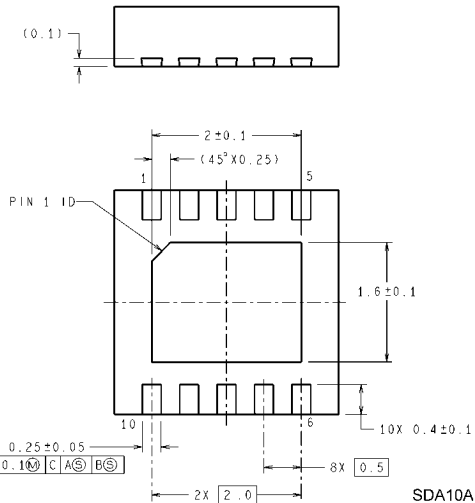
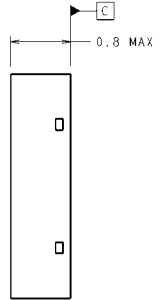
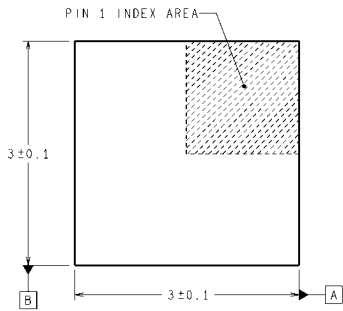

SDA10A (Rev A)

SDA10A: 10-Pin Non-Pullback Leadless Leadframe Package
3.0mm × 3.0mm × 0.8mm

Notes

THE CONTENTS OF THIS DOCUMENT ARE PROVIDED IN CONNECTION WITH NATIONAL SEMICONDUCTOR CORPORATION ("NATIONAL") PRODUCTS. NATIONAL MAKES NO REPRESENTATIONS OR WARRANTIES WITH RESPECT TO THE ACCURACY OR COMPLETENESS OF THE CONTENTS OF THIS PUBLICATION AND RESERVES THE RIGHT TO MAKE CHANGES TO SPECIFICATIONS AND PRODUCT DESCRIPTIONS AT ANY TIME WITHOUT NOTICE. NO LICENSE, WHETHER EXPRESS, IMPLIED, ARISING BY ESTOPPEL OR OTHERWISE, TO ANY INTELLECTUAL PROPERTY RIGHTS IS GRANTED BY THIS DOCUMENT.

TESTING AND OTHER QUALITY CONTROLS ARE USED TO THE EXTENT NATIONAL DEEMS NECESSARY TO SUPPORT NATIONAL'S PRODUCT WARRANTY. EXCEPT WHERE MANDATED BY GOVERNMENT REQUIREMENTS, TESTING OF ALL PARAMETERS OF EACH PRODUCT IS NOT NECESSARILY PERFORMED. NATIONAL ASSUMES NO LIABILITY FOR APPLICATIONS ASSISTANCE OR BUYER PRODUCT DESIGN. BUYERS ARE RESPONSIBLE FOR THEIR PRODUCTS AND APPLICATIONS USING NATIONAL COMPONENTS. PRIOR TO USING OR DISTRIBUTING ANY PRODUCTS THAT INCLUDE NATIONAL COMPONENTS, BUYERS SHOULD PROVIDE ADEQUATE DESIGN, TESTING AND OPERATING SAFEGUARDS.

EXCEPT AS PROVIDED IN NATIONAL'S TERMS AND CONDITIONS OF SALE FOR SUCH PRODUCTS, NATIONAL ASSUMES NO LIABILITY WHATSOEVER, AND NATIONAL DISCLAIMS ANY EXPRESS OR IMPLIED WARRANTY RELATING TO THE SALE AND/OR USE OF NATIONAL PRODUCTS INCLUDING LIABILITY OR WARRANTIES RELATING TO FITNESS FOR A PARTICULAR PURPOSE, MERCHANTABILITY, OR INFRINGEMENT OF ANY PATENT, COPYRIGHT OR OTHER INTELLECTUAL PROPERTY RIGHT.

LIFE SUPPORT POLICY

NATIONAL'S PRODUCTS ARE NOT AUTHORIZED FOR USE AS CRITICAL COMPONENTS IN LIFE SUPPORT DEVICES OR SYSTEMS WITHOUT THE EXPRESS PRIOR WRITTEN APPROVAL OF THE CHIEF EXECUTIVE OFFICER AND GENERAL COUNSEL OF NATIONAL SEMICONDUCTOR CORPORATION. As used herein:

Life support devices or systems are devices which (a) are intended for surgical implant into the body, or (b) support or sustain life and whose failure to perform when properly used in accordance with instructions for use provided in the labeling can be reasonably expected to result in a significant injury to the user. A critical component is any component in a life support device or system whose failure to perform can be reasonably expected to cause the failure of the life support device or system or to affect its safety or effectiveness.

National Semiconductor and the National Semiconductor logo are registered trademarks of National Semiconductor Corporation. All other brand or product names may be trademarks or registered trademarks of their respective holders.

Copyright© 2007 National Semiconductor Corporation

For the most current product information visit us at www.national.com



National Semiconductor Americas Customer Support Center
 Email: new.feedback@nsc.com
 Tel: 1-800-272-9959

National Semiconductor Europe Customer Support Center
 Fax: +49 (0) 180-530-85-86
 Email: europe.support@nsc.com
 Deutsch Tel: +49 (0) 69 9508 6208
 English Tel: +49 (0) 870 24 0 2171
 Français Tel: +33 (0) 1 41 91 8790

National Semiconductor Asia Pacific Customer Support Center
 Email: ap.support@nsc.com

National Semiconductor Japan Customer Support Center
 Fax: 81-3-5639-7507
 Email: jpn.feedback@nsc.com
 Tel: 81-3-5639-7560