

LM2780

Ultra-Low Ripple Switched Capacitor Voltage Inverter

General Description

The LM2780 is a charge pump that inverts an input voltage in the range of 1.8V to 5.5V to the corresponding output voltage of -1.8V to -5.5V. With use of three or four low-cost external ceramic capacitors, the LM2780 can provide up to 50mA of output current.

The LM2780 operates at a 12kHz typical switching frequency to minimize supply current (60 μ A typ.). Two charge pumps operate 180° out of phase to significantly reduce the output voltage ripple compared to that of traditional single-phase charge pump circuits. If larger output ripple can be tolerated, optional capacitor C2 may be omitted to reduce the cost and size of the solution. The LM2780 is available in an 8-pin Micro SMD chip-scale package.

See also: LM2781, a fast clock (210kHz typ) version of this topology with even lower output voltage ripple.

Features

- Inverts Input Voltage
- Ultra-Low Voltage Ripple and 8 Ω Typical Output Resistance with Two Flying Capacitors
- Output Resistance of 18 Ω Using One Flying Capacitor
- 12kHz (typ.) Switching Frequency
- 8-pin micro SMD Package (1.4mm x 1.4mm x 0.5mm)

Applications

- Cellular Phones
- Pagers
- PDAs
- Op-Amp Power Supplies
- Interface Power Supplies
- Handheld Instruments

Typical Application Circuit

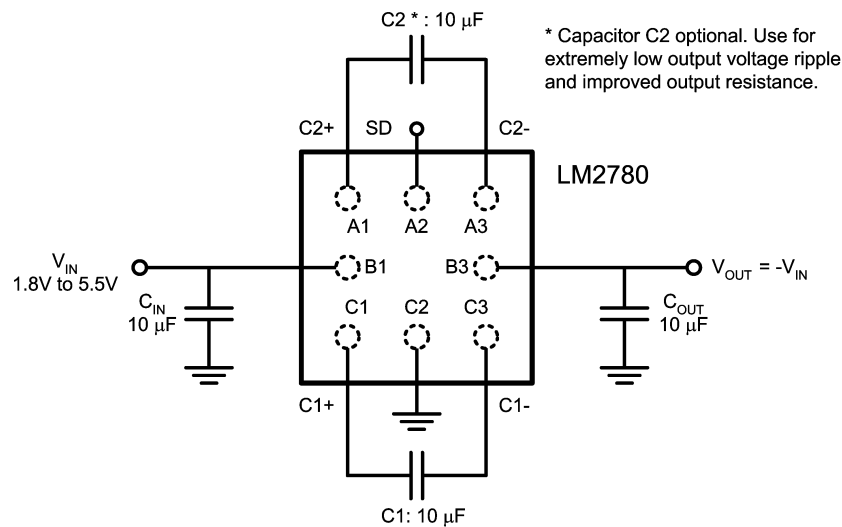

20044601

Connection Diagram

www.DataSheet4U.com

8-Bump Thin Micro SMD Package NS Package Number TPA08

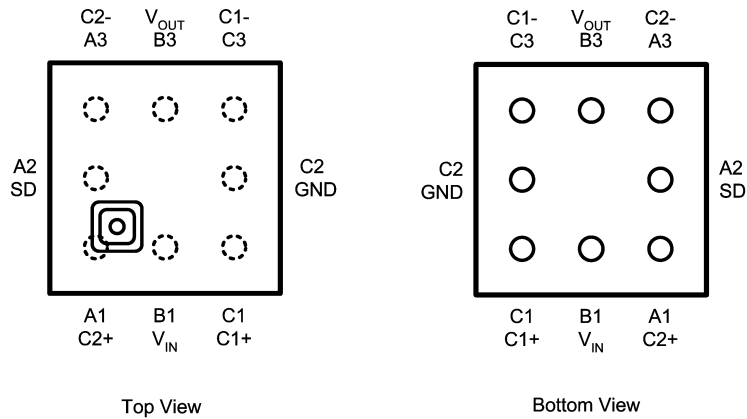

20044602

Pin Description

Pin	Name	Description
A1	C2+	Secondary flying-capacitor connection
B1	V _{IN}	Input voltage. Input range: 1.8V to 5.5V
C1	C1+	Primary flying-capacitor connection
A2	SD	Shutdown pin logic input. Low = on, High = shutdown
C2	GND	Ground
A3	C2-	Secondary flying-capacitor connection
B3	V _{OUT}	Output voltage. V _{OUT} = -V _{IN}
C3	C1-	Primary flying capacitor connection

Ordering Information

Order Number	Package Description	Package Marking	Supplied as
LM2780TP	TPA08: Thin Micro SMD	11	Tape and reel, 250 pcs.
LM2780TPX	TPA08: Thin Micro SMD	11	Tape and reel, 3000 pcs.

Absolute Maximum Ratings (Notes 1,

2)

If Military/Aerospace specified devices are required, please contact the National Semiconductor Sales Office/Distributors for availability and specifications.

V_{IN} pin: Voltage to GND	-0.3V to 5.8V
SD pin: Voltage to GND	-0.3V to $(V_{IN} + 0.3V)$, with 5.8V max
Output Short-to-GND Duration (Note 3)	1 sec.
Maximum Junction Temperature (T_{J-MAX})	150°C
Storage Temperature Range	-65°C to +150°C
Pad Temperature (Soldering, 10 sec.)	265°C

Electrical Characteristics (Notes 2, 7)

Limits in standard typeface are for $T_J = 25^\circ\text{C}$, and limits in **boldface** type apply over the full operating junction temperature range ($-40^\circ\text{C} \leq T_J \leq +90^\circ\text{C}$). Unless otherwise noted: specifications apply to the LM2780 Typical Application Circuit (pg. 1) with $V_{IN} = 5.0\text{V}$, $V(\text{SD}) = 0\text{V}$, and $C_{IN} = C_{OUT} = C1 = C2 = 10\mu\text{F}$. (Note 8)

Symbol	Parameter	Conditions	Min	Typ	Max	Units
R_{OUT}	Output Resistance (Note 9)	$I_{OUT} = 10\text{mA}$, $C2 = 10\mu\text{F}$		8	30	Ω
		$I_{OUT} = 10\text{mA}$, $C2$ removed		18	40	Ω
I_Q	Supply Current	No load		60	120	μA
I_{SD}	Shutdown Supply Current	$V(\text{SD}) = 5.0\text{V}$		0.1	0.5	μA
F_{SW}	Switching Frequency		6	12	28	kHz
V_{SD}	Shutdown Pin Logic Levels	Normal Operation $1.8\text{V} \leq V_{IN} \leq 5.5\text{V}$	0		0.5	V
		Shutdown Mode $1.8\text{V} \leq V_{IN} \leq 5.5\text{V}$	$0.5 \times V_{IN}$		V_{IN}	
V_{OUTP-P}	Output Voltage Ripple	$V_{IN} = 5.0\text{V}$, $I_{OUT} = 10\text{mA}$		40		mV
P_{EFF}	Power Efficiency	$V_{IN} = 5.0\text{V}$, $I_{OUT} = 10\text{mA}$		98		%

Note 1: Absolute Maximum Ratings indicate limits beyond which damage to the component may occur. Operating Ratings are conditions under which operation of the device is guaranteed. Operating Ratings do not imply guaranteed performance limits. For guaranteed performance limits and associated test conditions, see the Electrical Characteristics table.

Note 2: All voltages are with respect to the potential at the GND pin.

Note 3: V_{OUT} may be shorted to GND for one second without damage when the ambient temperature is at or below 85°C . Prolonged or repeated shorts of V_{OUT} to GND may damage the device, and should be avoided.

Note 4: The human-body model is a 100pF capacitor discharged through a 1.5k Ω resistor into each pin. The machine model is a 200pF capacitor discharged directly into each pin.

Note 5: Maximum ambient temperature (T_{A-MAX}) is dependent on the maximum operating junction temperature ($T_{J-MAX-OP} = 90^\circ\text{C}$), the maximum power dissipation of the device in the application (P_{D-MAX}), and the junction-to-ambient thermal resistance of the part in the application (θ_{JA}), as given by the following equation: $T_{A-MAX} = T_{J-MAX-OP} - (\theta_{JA} \times P_{D-MAX})$.

Note 6: Junction-to-ambient thermal resistance of the micro SMD package is highly application and board-layout dependent.

Note 7: Max and Min limits are guaranteed by design, test, or statistical analysis. Typical numbers are not guaranteed, but do represent the most likely norm.

Note 8: C_{IN} , C_{OUT} , C1, and C2: Low-ESR Surface-Mount Ceramic Capacitors (MLCCs) used in setting electrical characteristics.

Note 9: Output resistance is a model for the voltage drop at the output, resulting from internal switch resistance, capacitor ESR, and charge pump charge transfer characteristics. Output voltage can be predicted with the following equation: $V_{OUT} = -[V_{IN} - (I_{OUT} \times R_{OUT})]$

ESD Rating (Note 4)

Human-body model

2kV

Machine model

200V

Operating Ratings (Notes 1, 2)

Input Voltage Range	1.8V to 5.5V
Junction Temperature (T_J) Range	-40°C to +90°C
Ambient Temperature (T_A) Range (Note 5)	-40°C to +85°C

Thermal Properties

Junction-to-Ambient Thermal Resistance (θ_{JA}), TPA08 Package (Note 6)	220°C/W
--	---------

Typical Performance Characteristics

Unless otherwise specified, $T_A = 25^\circ\text{C}$, $C_{IN} = C_{OUT} = C1 = C2 = 10\mu\text{F}$.

Output Voltage vs. Load Current

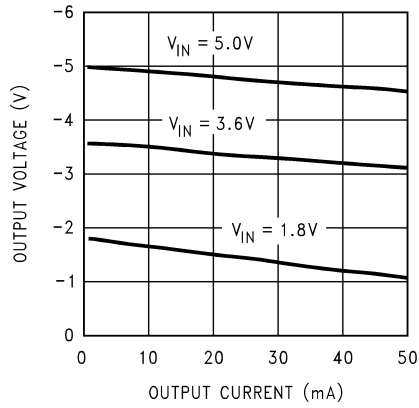

20044603

Power Efficiency vs. Load Current

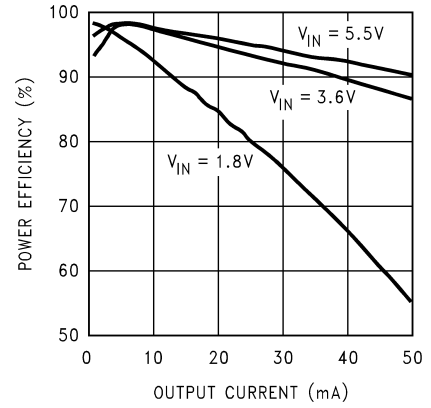

20044604

Output Resistance vs. Temperature ($I_{OUT} = 10\text{mA}$)

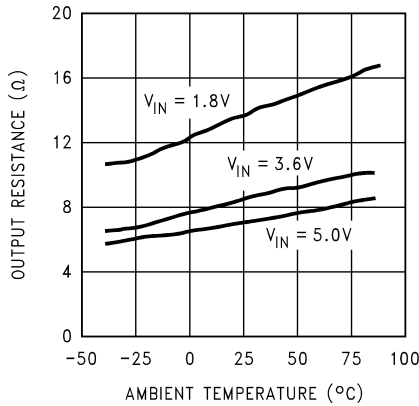

20044605

Supply Current vs. Temperature ($I_{OUT} = 0$)

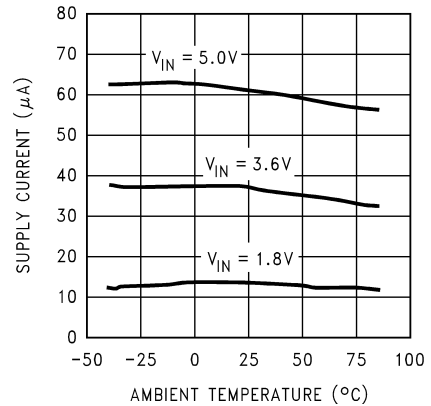

20044606

Switching Frequency vs. Temperature

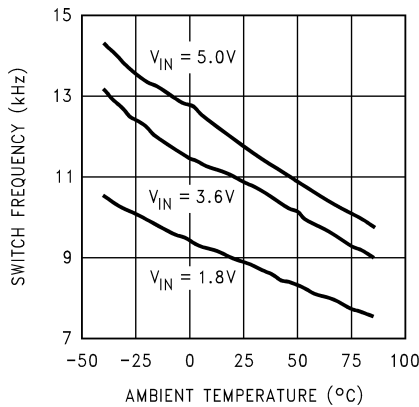

20044607

Output Voltage Ripple vs. Output Current

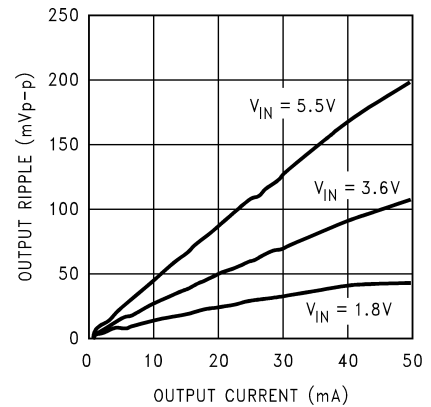

20044608

Block Diagram

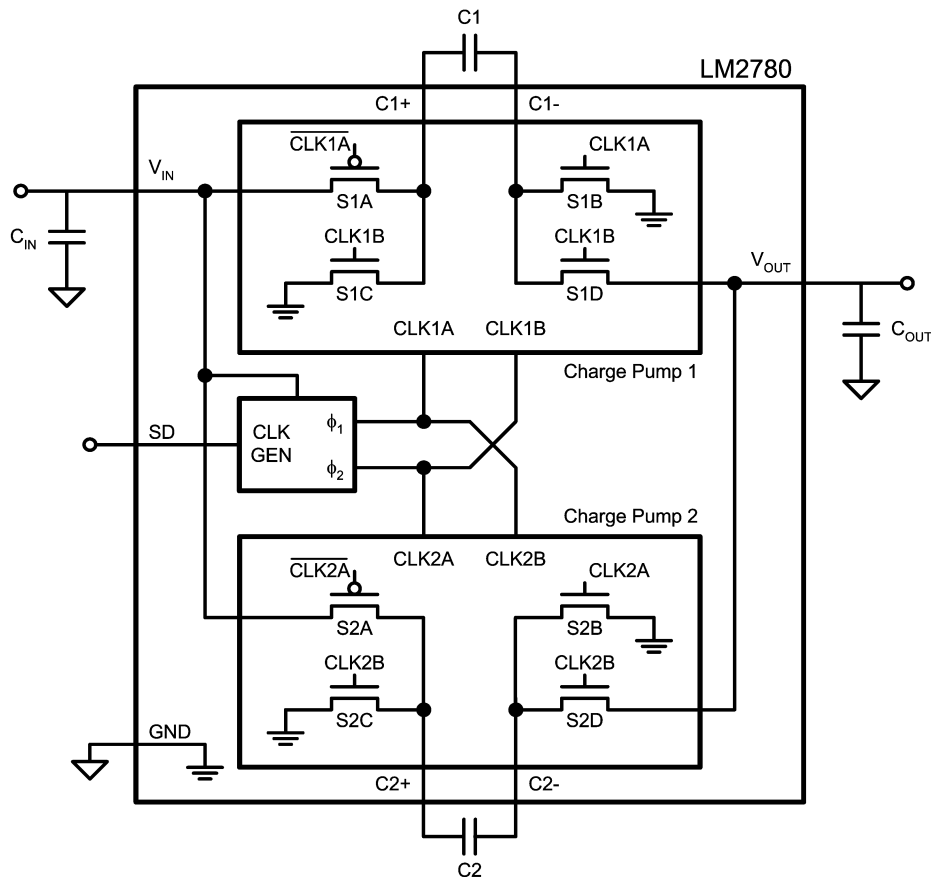

20044610

Operation Description

The LM2780 is a switched capacitor voltage inverter that produces a negative output voltage from a positive input voltage. To minimize output voltage ripple, the LM2780 contains two charge pump inverters that operate 180° out of phase. These two charge pumps can be seen in the block diagram above.

A basic switched capacitor inverter is a two-phase charge pump circuit that transfers charge from the input to the output using a flying capacitor. Charge Pump 1 in the block diagram will be used to illustrate the operation of a single charge pump. Disregard Charge Pump 2 in the diagram for now. In phase 1 (ϕ_1), the CLK1A signal of Charge Pump 1 is high, and MOSFET switches S1A and S1B are ON. For Charge Pump 1, this is the charge phase, as the flying capacitor C1 is charged to the input voltage. In the second phase (ϕ_2), the positive-charged plate of C1 is connected to GND through switch S1C, and the negative-charged plate is connected to the output through switch S1D. This results in the output voltage being approximately equal in magnitude to the input voltage, but opposite in sign ($V_{OUT} \approx -V_{IN}$). In this pump phase, charge stored on the flying capacitor supplies the current to the load and transfers charge to the output capacitor.

This basic inverter has ripple in the output voltage. During the charge phase, the load current is supplied by the charge on the output capacitor. As charge is pulled off C_{OUT} , the voltage across the capacitor drops, and the magnitude of the output voltage ($|V_{OUT}|$) falls. During the pump phase, the

flying capacitor transfers charge to the C_{OUT} , elevating both the voltage across the C_{OUT} and the magnitude of the output voltage.

The LM2780 contains two charge pump inverters running 180° out of phase. Notice in the block diagram that the clock connections on Charge Pump 2 are opposite of the clock connections to Charge Pump 1. Thus, when Charge Pump 1 is in the charge phase, Charge Pump 2 is in the pump phase, and vice-versa. With this double-pump technology, there is always a flying capacitor connected to the output. This results in significantly lower output voltage ripple than that of a single-pump inverter.

OUTPUT VOLTAGE RIPPLE

Several factors influence the magnitude of voltage ripple on the output of the LM2780. Primary influences are output capacitance, flying capacitance, load current, input voltage, and output capacitor ESR.

The magnitude of the output voltage ripple is difficult to predict with equations when the LM2780 is double pumping. Refer to the Typical Performance Characteristic curves for this information. In general, ripple decreases with increased output capacitance, decreased load current, a lower input voltage, a smaller flying capacitance and/or a smaller output capacitor ESR.

When only one charge pump is active (C2 removed), the output ripple is more predictable, and can be estimated with the following equation:

$$V_{\text{RIPPLE}} = [(0.5 \times I_{\text{OUT}}) / (f_{\text{SW}} \times C_{\text{OUT}})] + (2 \times I_{\text{OUT}} \times \text{ESR}_{\text{Cout}})$$

Operation Description (Continued)

OUTPUT RESISTANCE

Output resistance (R_{OUT}) models the internal non-idealities of a charge pump that result in droop in the output voltage. The effect of output resistance on output voltage is expressed in the following equation:

$$V_{OUT} = - [V_{IN} - (|I_{OUT}| \times R_{OUT})]$$

Output resistance is a function of the internal switch resistance (R_{SW}), flying capacitance ($C1$), flying capacitor equivalent series resistance (ESR_{C1}), output capacitor ESR (ESR_{Cout}), and internal switching frequency (f_{SW}). When the LM2780 operates as a single charge pump ($C2$ removed), the output resistance can be approximated by the following equation:

$$1 \text{ Fly Cap: } R_{OUT1} \sim 2R_{SW1} + [1/(f_{SW} * C1)] + 4ESR_{C1} + ESR_{Cout}$$

R_{SW1} is the sum of the ON resistance of the four internal MOSFET switches of Charge Pump 1.

With both $C1$ and $C2$ in place, the double pumping topology of the LM2780 cuts the output resistance in half:

$$2 \text{ Fly Caps: } R_{OUT2} \sim 0.5 \times R_{OUT1}$$

Recommendations for minimizing output resistance include increasing flying capacitance and minimizing output and flying capacitor ESR.

CAPACITOR SELECTION

Surface-mount multi-layer ceramic capacitors are recommended for use with the LM2780. These capacitors are small, inexpensive and have very low equivalent series resistance (ESR, $< 15\text{m}\Omega$ typ.). Tantalum capacitors, OS-CON capacitors, and aluminum electrolytic capacitors generally are not recommended for use with the LM2780 due to their high ESR, as compared to ceramic capacitors.

For most applications, ceramic capacitors with X7R or X5R temperature characteristic are preferred for use with the LM2780. These capacitors have tight capacitance tolerance (as good as $\pm 10\%$), hold their value over temperature (X7R: $\pm 15\%$ over -55°C to 125°C ; X5R: $\pm 15\%$ over -55°C to 85°C), and typically have little voltage coefficient.

Capacitors with Y5V and/or Z5U temperature characteristic are generally not recommended for use with the LM2780. These types of capacitors typically have wide capacitance tolerance ($+80\%$, -20%), vary significantly over temperature (Y5V: $+22\%$, -82% over -30°C to $+85^\circ\text{C}$ range; Z5U: $+22\%$, -56% over $+10^\circ\text{C}$ to $+85^\circ\text{C}$ range), and have poor voltage coefficients. Under some conditions, a nominal $1\mu\text{F}$ Y5V or Z5U capacitor could have a capacitance of only $0.1\mu\text{F}$. Such deviation would severely affect performance of the LM2780 circuit.

Physical Dimensions inches (millimeters) unless otherwise noted

www.DataSheet4U.com

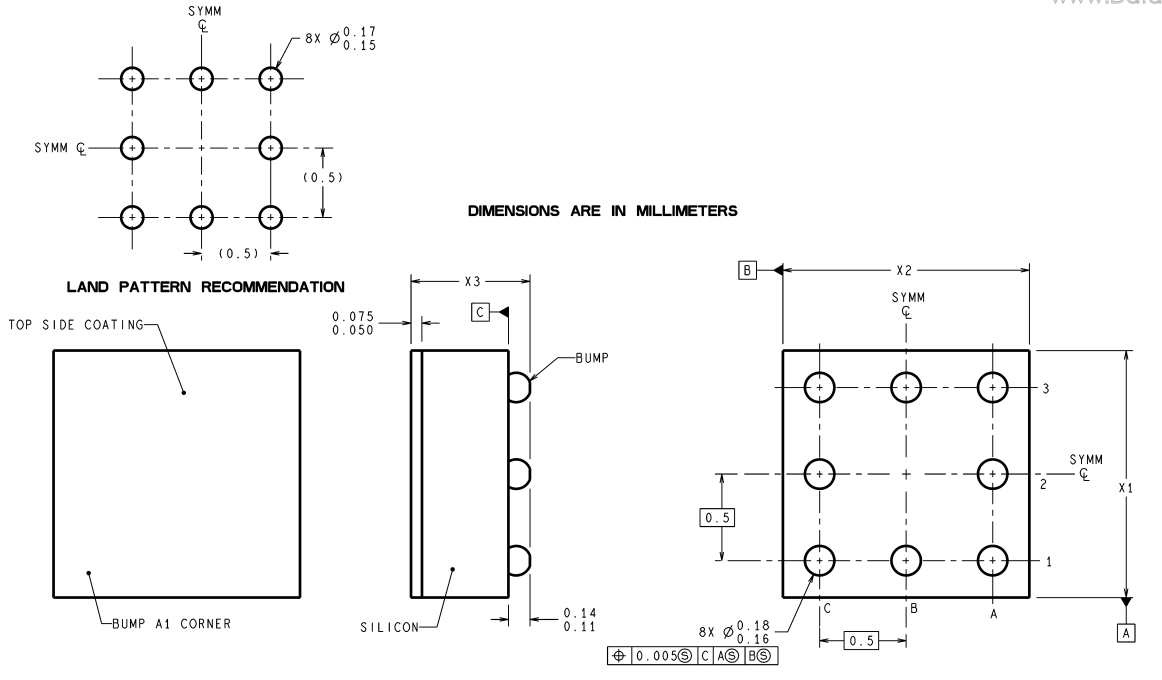

TPA08: 8-Bump Thin Micro SMD
X1 = X2 = 1.361mm ± 0.030mm
X3 = 0.500mm ± 0.075mm

LIFE SUPPORT POLICY

NATIONAL'S PRODUCTS ARE NOT AUTHORIZED FOR USE AS CRITICAL COMPONENTS IN LIFE SUPPORT DEVICES OR SYSTEMS WITHOUT THE EXPRESS WRITTEN APPROVAL OF THE PRESIDENT AND GENERAL COUNSEL OF NATIONAL SEMICONDUCTOR CORPORATION. As used herein:

1. Life support devices or systems are devices or systems which, (a) are intended for surgical implant into the body, or (b) support or sustain life, and whose failure to perform when properly used in accordance with instructions for use provided in the labeling, can be reasonably expected to result in a significant injury to the user.
2. A critical component is any component of a life support device or system whose failure to perform can be reasonably expected to cause the failure of the life support device or system, or to affect its safety or effectiveness.



National Semiconductor
Americas Customer Support Center
Email: new.feedback@nsc.com
Tel: 1-800-272-9959

National Semiconductor
Europe Customer Support Center
Fax: +49 (0) 180-530 85 86
Email: europe.support@nsc.com
Deutsch Tel: +49 (0) 69 9508 6208
English Tel: +44 (0) 870 24 0 2171
Français Tel: +33 (0) 1 41 91 8790

National Semiconductor
Asia Pacific Customer Support Center
Fax: +65-6250 4466
Email: ap.support@nsc.com
Tel: +65-6254 4466

National Semiconductor
Japan Customer Support Center
Fax: 81-3-5639-7507
Email: jpn.feedback@nsc.com
Tel: 81-3-5639-7560

www.national.com