

# LM27

## SOT-23, $\pm 3^\circ\text{C}$ Accurate, $120^\circ\text{C}$ - $150^\circ\text{C}$ Factory Preset Thermostat

### General Description

The LM27 is a precision, single digital-output, low-power thermostat comprised of an internal reference, DAC, temperature sensor and comparator. Utilizing factory programming, it can be manufactured with different trip points as well as different digital output functionality. The trip point ( $T_{OS}$ ) can be preset at the factory to any temperature in the range of  $+120^\circ\text{C}$  to  $+150^\circ\text{C}$  in  $1^\circ\text{C}$  increments. The LM27 has one digital output ( $OS/\overline{OS}/US/\overline{US}$ ), one digital input (HYST) and one analog output ( $V_{TEMP}$ ). The digital output stage can be preset as either open-drain or push-pull. In addition, it can be factory programmed to be active HIGH or LOW. The digital output can be factory programmed to indicate an over temperature shutdown event ( $OS$  or  $\overline{OS}$ ) or an under temperature shutdown event ( $US$  or  $\overline{US}$ ). When preset as an over-temperature shutdown ( $\overline{OS}$ ) it will go LOW to indicate that the die temperature is over the internally preset  $T_{OS}$  and go HIGH when the temperature goes below ( $T_{OS}-T_{HYST}$ ). Similarly, when preprogrammed as an undertemperature shutdown ( $US$ ) it will go HIGH to indicate that the temperature is below  $T_{US}$  and go LOW when the temperature is above ( $T_{US}+T_{HYST}$ ). The typical hysteresis,  $T_{HYST}$ , can be set to  $2^\circ\text{C}$  or  $10^\circ\text{C}$  and is controlled by the state of the HYST pin. A  $V_{TEMP}$  analog output provides a voltage that is proportional to temperature and has a  $-10.7\text{mV}/^\circ\text{C}$  output slope.

Currently, there are several standard parts available, see ordering information for details. For other part options, contact a National Semiconductor Distributor or Sales Representative for information on minimum order qualification. The LM27 is currently available in a 5-lead SOT-23 package.

### Applications

- Microprocessor Thermal Management
- Appliances
- Portable Battery Powered Systems
- Fan Control
- Industrial Process Control
- HVAC Systems
- Electronic System Protection

### Features

- Internal comparator with pin selectable  $2^\circ\text{C}$  or  $10^\circ\text{C}$  hysteresis
- No external components required
- Open-drain or push-pull digital output; supports CMOS logic levels
- Internal temperature sensor with  $V_{TEMP}$  output pin
- $V_{TEMP}$  output allows after-assembly system testing
- Internal voltage reference and DAC for trip-point setting
- Currently available in 5-pin SOT-23 plastic package
- Excellent power supply noise rejection

### Key Specifications

■ Power Supply Voltage	2.7V to 5.5V
■ Power Supply Current	40 $\mu\text{A}$ (max) 15 $\mu\text{A}$ (typ)
■ Hysteresis Temperature	$2^\circ\text{C}$ or $10^\circ\text{C}$ (typ)
■ Temperature Trip Point Accuracy	$\pm 3^\circ\text{C}$ (max)

### LM27CIM5-2HJ Simplified Block Diagram and Connection Diagram

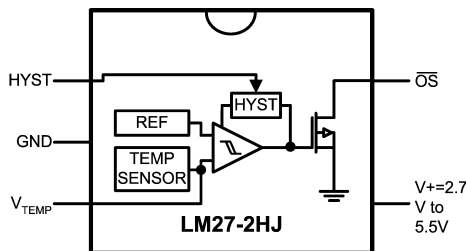

HYST=GND for  $10^\circ\text{C}$  Hysteresis  
 HYST=V+ for  $2^\circ\text{C}$  Hysteresis  
 $V_{TEMP} = (-3.552 \times 10^{-6} \times (T-30)^2) + (-10.69576 \times 10^{-3} \times (T-30)) + 1.8386\text{V}$

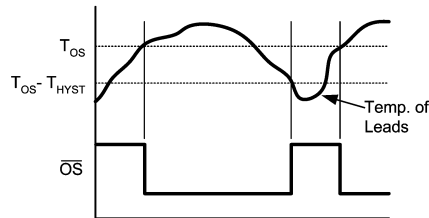

20030701

**The LM27CIM5-2HJ has a fixed trip point of  $140^\circ\text{C}$ .**  
**For other trip point and output function availability,**  
**please see ordering information or contact National Semiconductor.**

LM27 SOT-23,  $\pm 3^\circ\text{C}$  Accurate,  $120^\circ\text{C}$ - $150^\circ\text{C}$  Factory Preset Thermostat

## Ordering Information

For more detailed information on the suffix meaning see the part number template at the end of the Electrical Characteristics Section. Contact National Semiconductor for other set points and output options.

Order Number		Top Mark	NS Package Number	Trip Point Setting	Output Function
Bulk Rail	3000 Units in Tape & Reel				
LM27CIM5-ZHJ	LM27CIM5X-ZHJ	TZHJ	MA05B	120°C	Open Drain $\overline{OS}$
LM27CIM5-1HJ	LM27CIM5X-1HJ	T1HJ	MA05B	130°C	Open Drain $\overline{OS}$
LM27CIM5-2HJ	LM27CIM5X-2HJ	T2HJ	MA05B	140°C	Open Drain $\overline{OS}$

## Connection Diagram

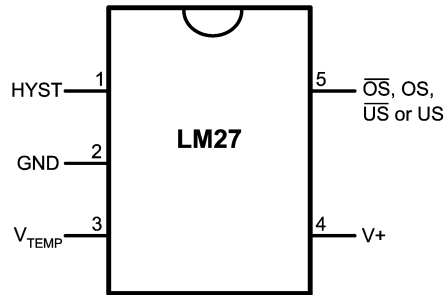

20030702

## Pin Descriptions

Pin Number	Pin Name	Function	Connection
1	HYST	Hysteresis control, digital input	GND for 10°C or V <sup>+</sup> for 2°C
2	GND	Ground, connected to the back side of the die through lead frame.	System GND
3	V <sub>TEMP</sub>	Analog output voltage proportional to temperature	Leave floating or connect to a high impedance node.
4	V <sup>+</sup>	Supply input	2.7V to 5.5V with a 0.1μF bypass capacitor. For PSRR information see <i>Section Titled NOISE CONSIDERATIONS</i> .
5	$\overline{OS}$	Overtemperature Shutdown open-drain active low thermostat digital output	Controller interrupt, system or power supply shutdown; pull-up resistor $\geq 10k\Omega$
	OS	Overtemperature Shutdown totem-pull active high thermostat digital output	Controller interrupt, system or power supply shutdown
	$\overline{US}$	Undertemperature Shutdown open-drain active low thermostat digital output	System or power supply shutdown; pull-up resistor $\geq 10k\Omega$
	US	Undertemperature Shutdown totem-pull active high thermostat digital output	System or power supply shutdown

Note: pin 5 functionality and trip point setting are programmed during LM27 manufacture.

**Absolute Maximum Ratings** (Note 1)

Input Voltage	6.0V
Input Current at any pin (Note 2)	5mA
Package Input Current (Note 2)	20mA
Package Dissipation at $T_A = 25^\circ\text{C}$ (Note 3)	500mW
Soldering Information	
SOT23 Package	
Vapor Phase (60 seconds)	215°C
Infrared (15 seconds)	220°C
Storage Temperature	-65°C to +150°C

## ESD Susceptibility (Note 4)

Human Body Model	2500V
Machine Model	250V

**Operating Ratings** (Note 1)

Specified Temperature Range	$T_{\text{MIN}} \leq T_A \leq T_{\text{MAX}}$
LM27CIM	$-40^\circ\text{C} \leq T_A \leq +150^\circ\text{C}$
Positive Supply Voltage ( $V^+$ )	+2.7V to +5.5V
Maximum $V_{\text{OUT}}$	+5.5V

**LM27 Electrical Characteristics**

The following specifications apply for  $V^+ = 2.7V_{\text{DC}}$  to  $5.5V_{\text{DC}}$ , and  $V_{\text{TEMP}}$  load current =  $0\mu\text{A}$  unless otherwise specified. **Bold-face limits apply for  $T_A = T_J = T_{\text{MIN}}$  to  $T_{\text{MAX}}$** ; all other limits  $T_A = T_J = 25^\circ\text{C}$  unless otherwise specified.

Symbol	Parameter	Conditions	Typical (Note 6)	LM27CIM Limits (Note 7)	Units (Limits)
<b>Temperature Sensor</b>					
	Trip Point Accuracy (Includes $V_{\text{REF}}$ , DAC, Comparator Offset, and Temperature Sensitivity errors)	$+120^\circ\text{C} < T_A < +150^\circ\text{C}$		$\pm 3$	$^\circ\text{C}$ (max)
	Trip Point Hysteresis	HYST = GND	10		$^\circ\text{C}$
		HYST = $V^+$	2		$^\circ\text{C}$
	$V_{\text{TEMP}}$ Output Temperature Sensitivity		-10.82		mV/ $^\circ\text{C}$
	$V_{\text{TEMP}}$ Temperature Sensitivity Error to Equation: $V_O = (-3.552 \times 10^{-6} \times (T-30)^2 + (-10.695 \times 10^{-3} \times (T-30)) + 1.8386\text{V}$	$-30^\circ\text{C} \leq T_A \leq 150^\circ\text{C}$ , $2.7\text{V} \leq V^+ \leq 5.5\text{V}$		<b><math>\pm 3</math></b>	$^\circ\text{C}$ (max)
		$-55^\circ\text{C} \leq T_A \leq 150^\circ\text{C}$ , $4.5\text{V} \leq V^+ \leq 5.5\text{V}$		<b><math>\pm 3</math></b>	$^\circ\text{C}$ (max)
		$T_A = 25^\circ\text{C}$			$\pm 2.5$
	$V_{\text{TEMP}}$ Load Regulation	Source $\leq 1\mu\text{A}$	0.070		mV
		Sink $\leq 40\mu\text{A}$			<b>0.7</b>
	$V_{\text{TEMP}}$ Line Regulation	$+2.7\text{V} \leq V^+ \leq +5.5\text{V}$ , $-30^\circ\text{C} \leq T_A \leq +120^\circ\text{C}$	-0.2		mV/V
$I_S$	Supply Current		15	22	$\mu\text{A}$ (max)
				<b>40</b>	$\mu\text{A}$ (max)
<b>Digital Output and Input</b>					
$I_{\text{OUT}}("1")$	Logical "1" Output Leakage Current (Note 9)	$V^+ = +5.0\text{V}$	0.001	<b>1</b>	$\mu\text{A}$ (max)
$V_{\text{OUT}}("0")$	Logical "0" Output Voltage	$I_{\text{OUT}} = +1.2\text{mA}$ and $V^+ \geq 2.7\text{V}$ ; $I_{\text{OUT}} = +3.2\text{mA}$ and $V^+ \geq 4.5\text{V}$ ; (Note 8)		<b>0.4</b>	V (max)
$V_{\text{OUT}}("1")$	Logical "1" Push-Pull Output Voltage	$I_{\text{SOURCE}} = 500\mu\text{A}$ , $V^+ \geq 2.7\text{V}$		<b><math>0.8 \times V^+</math></b>	V (min)
		$I_{\text{SOURCE}} = 800\mu\text{A}$ , $V^+ \geq 4.5\text{V}$		<b><math>V^+ - 1.5</math></b>	V (min)
$V_{\text{IH}}$	HYST Input Logical "1" Threshold Voltage			<b><math>0.8 \times V^+</math></b>	V (min)
$V_{\text{IL}}$	HYST Input Logical "0" Threshold Voltage			<b><math>0.2 \times V^+</math></b>	V (max)

## LM27 Electrical Characteristics (Continued)

**Note 1:** Absolute Maximum Ratings indicate limits beyond which damage to the device may occur. Operating Ratings indicate conditions for which the device is functional, but do not guarantee specific performance limits. For guaranteed specifications and test conditions, see the Electrical Characteristics. The guaranteed specifications apply only for the test conditions listed. Some performance characteristics may degrade when the device is not operated under the listed test conditions.

**Note 2:** When the input voltage ( $V_I$ ) at any pin exceeds the power supply ( $V_I < \text{GND}$  or  $V_I > V^+$ ), the current at that pin should be limited to 5mA. The 20mA maximum package input current rating limits the number of pins that can safely exceed the power supplies with an input current of 5mA to four. Under normal operating conditions the maximum current that pins 2, 4 or 5 can handle is limited to 5mA each.

**Note 3:** The maximum power dissipation must be derated at elevated temperatures and is dictated by  $T_{Jmax}$  (maximum junction temperature),  $\theta_{JA}$  (junction to ambient thermal resistance) and  $T_A$  (ambient temperature). The maximum allowable power dissipation at any temperature is  $P_D = (T_{Jmax} - T_A) / \theta_{JA}$  or the number given in the Absolute Maximum Ratings, whichever is lower. For this device,  $T_{Jmax} = 150^\circ\text{C}$ . For this device the typical thermal resistance ( $\theta_{JA}$ ) of the different package types when board mounted follow:

Package Type	$\theta_{JA}$
SOT23-5, MA05B	250°C/W

**Note 4:** The human body model is a 100pF capacitor discharge through a 1.5k $\Omega$  resistor into each pin. The machine model is a 200pF capacitor discharged directly into each pin.

**Note 5:** See the URL "http://www.national.com/packaging/" for other recommendations and methods of soldering surface mount devices.

**Note 6:** Typicals are at  $T_J = T_A = 25^\circ\text{C}$  and represent most likely parametric norm.

**Note 7:** Limits are guaranteed to National's AOQL (Average Outgoing Quality Level).

**Note 8:** Care should be taken to include the effects of self heating when setting the maximum output load current. The power dissipation of the LM27 would increase by 1.28mW when  $I_{OUT} = 3.2\text{mA}$  and  $V_{OUT} = 0.4\text{V}$ . With a thermal resistance of 250°C/W, this power dissipation would cause an increase in the die temperature of about 0.32°C due to self heating. Self heating is not included in the trip point accuracy specification.

**Note 9:** The 1 $\mu\text{A}$  limit is based on a testing limitation and does not reflect the actual performance of the part. Expect to see a doubling of the current for every 15°C increase in temperature. For example, the 1nA typical current at 25°C would increase to 16nA at 85°C.

## Part Number Template

The series of digits labeled xyz in the part number LM27CIM-xyz, describe the set point value and the function of the output as follows:

The place holders xy describe the set point temperature as shown in the following table.

x (10x)	y (1x)	Temperature (°C)
-	H	0
-	J	1
-	K	2
-	L	3
-	N	4
-	P	5
-	R	6

x (10x)	y (1x)	Temperature (°C)
-	S	7
-	T	8
-	V	9
Z	-	12
1	-	13
2	-	14
3	-	15

The value of z describes the assignment/function of the output as shown in the following table:

Active-Low/High	Open-Drain/ Push-Pull	$\overline{\text{OS}}/\text{US}$	Value of z	Digital Output Function
0	0	0	J	Active-Low, Open-Drain, $\overline{\text{OS}}$ output
0	0	1	K	Active-Low, Open-Drain, $\overline{\text{US}}$ output
1	1	0	L	Active-High, Push-Pull, OS output
1	1	1	N	Active-High, Push-Pull, US output

For example:

- the part number LM27CIM5-2SJ has  $T_{OS} = 147^\circ\text{C}$ , and programmed as an active-low open-drain overtemperature shutdown output.
- the part number LM27CIM5-ZLN has  $T_{US} = 123^\circ\text{C}$ , and programmed as an active-high, push-pull undertemperature shutdown output.

Active-high open-drain and active-low push-pull options are available, please contact National Semiconductor for more information.

## Functional Description

### LM27 OPTIONS

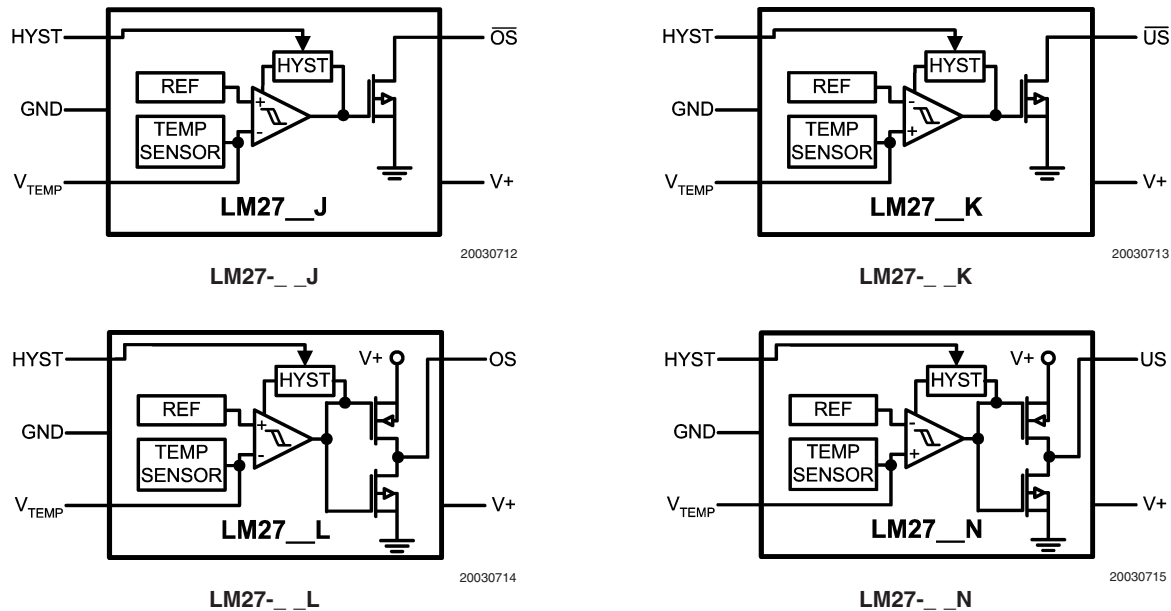

FIGURE 1. Output Pin Options Block Diagrams

The LM27 can be factory programmed to have a trip point anywhere in-between 120°C to 150°C.

## Applications Hints

### AFTER-ASSEMBLY PCB TESTING

The LM27's  $V_{TEMP}$  output allows after-assembly PCB testing by following a simple test procedure. Simply measuring the  $V_{TEMP}$  output voltage will verify that the LM27 has been assembled properly and that its temperature sensing circuitry is functional. The  $V_{TEMP}$  output has very weak drive capability that can be overdriven by 1.5mA. Therefore, one can simply force the  $V_{TEMP}$  voltage to cause the digital output to change state, thereby verifying that the comparator and output circuitry function after assembly. Here is a sample test procedure that can be used to test the LM27CIM5X-2HJ which has a 140°C trip point.

1. Turn on  $V^+$  and measure  $V_{TEMP}$ . Then calculate the temperature reading of the LM27 using the equation:

$$V_O = (-3.552 \times 10^{-6} \times (T-30)^2) + (-10.69576 \times 10^{-3} \times (T-30)) + 1.8386V \quad (1)$$

or

$$T = -1475.49 + \sqrt{2.2668 \times 10^6 + \frac{1.8386 - V_{TEMP}}{3.552 \times 10^{-6}}} \quad (2)$$

2. Verify that the temperature measured in step one is within ( $\pm 3^\circ\text{C}$  + error of reference temperature sensor) of the ambient/board temperature. The ambient/board temperature (reference temperature) should be measured using an extremely accurate calibrated temperature sensor, which is in close proximity to and mounted on the same PCB as the LM27 perhaps even touching the GND lead of the LM27 if possible. The LM27 will sense the

board temperature not the ambient temperature (see *Section Titled Mounting Considerations*)

3.
  - A. Observe that  $\overline{OS}$  is high.
  - B. Drive  $V_{TEMP}$  to ground.
  - C. Observe that  $\overline{OS}$  is now low.
  - D. Release the  $V_{TEMP}$  pin.
  - E. Observe that  $\overline{OS}$  is now high.
4.
  - A. Observe that  $\overline{OS}$  is high.
  - B. Drive  $V_{TEMP}$  voltage down gradually.
  - C. When  $\overline{OS}$  goes low, note the  $V_{TEMP}$  voltage.
  - D.  $V_{TEMP}Trig = V_{TEMP}$  at  $\overline{OS}$  trigger (HIGH->LOW)
  - E. Calculate  $T_{trig}$  using *Equation (2)*.
5.
  - A. Gradually raise  $V_{TEMP}$  until  $\overline{OS}$  goes HIGH. Note  $V_{TEMP}$ .
  - B. Calculate  $T_{HYST}$  using *Equation (2)*.

### $V_{TEMP}$ LOADING

The  $V_{TEMP}$  output has very weak drive capability (1  $\mu\text{A}$  source, 40  $\mu\text{A}$  sink). So care should be taken when attaching circuitry to this pin. Capacitive loading may cause the  $V_{TEMP}$  output to oscillate. Simply adding a resistor in series as shown in *Figure 2* will prevent oscillations from occurring. To determine the value of the resistor follow the guidelines given in *Table 1*. The same value resistor will work for either placement of the resistor. If an additional capacitive load is placed directly on the LM27 output, rather than across  $C_{LOAD}$ , it should be at least a factor of 10 smaller than  $C_{LOAD}$ .

## Applications Hints (Continued)

**TABLE 1. Resistive compensation for capacitive loading of  $V_{TEMP}$**

$C_{LOAD}$	R ( $\Omega$ )
$\leq 100\text{pF}$	0
1nF	8200
10nF	3000
100nF	1000
$\geq 1\mu\text{F}$	430

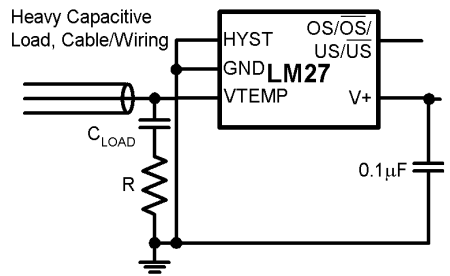

a) R in series with capacitor

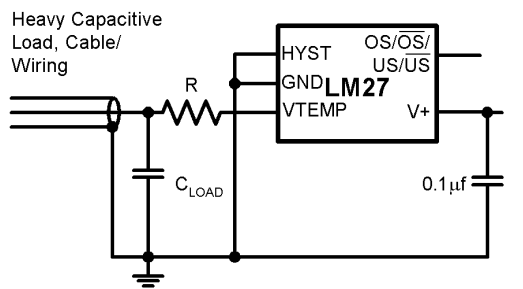

b) R in series with signal path

**FIGURE 2. Resistor placement for capacitive loading compensation of  $V_{TEMP}$**

### NOISE CONSIDERATIONS

The LM27 has excellent power supply noise rejection. Listed below is a variety of signals used to test the LM27 power supply rejection. False triggering of the output was not observed when these signals were coupled into the  $V+$  pin of the LM27.

- square wave 400kHz, 1Vp-p
- square wave 2kHz, 200mVp-p
- sine wave 100Hz to 1MHz, 200mVp-p

Testing was done while maintaining the temperature of the LM27 one degree centigrade away from the trip point with the output not activated.

### MOUNTING CONSIDERATIONS

The LM27 can be applied easily in the same way as other integrated-circuit temperature sensors. It can be glued or cemented to a surface. The temperature that the LM27 is sensing will be within about  $+0.06^\circ\text{C}$  of the surface temperature to which the LM27's leads are attached to.

This presumes that the ambient air temperature is almost the same as the surface temperature; if the air temperature were much higher or lower than the surface temperature, the actual temperature measured would be at an intermediate temperature between the surface temperature and the air temperature.

To ensure good thermal conductivity, the backside of the LM27 die is directly attached to the GND pin (pin 2). The temperatures of the lands and traces to the other leads of the LM27 will also affect the temperature that is being sensed.

Alternatively, the LM27 can be mounted inside a sealed-end metal tube, and can then be dipped into a bath or screwed into a threaded hole in a tank. As with any IC, the LM27 and accompanying wiring and circuits must be kept insulated and dry, to avoid leakage and corrosion. This is especially true if the circuit may operate at cold temperatures where condensation can occur. Printed-circuit coatings and varnishes such as Humiseal and epoxy paints or dips are often used to ensure that moisture cannot corrode the LM27 or its connections.

The junction to ambient thermal resistance ( $\theta_{JA}$ ) is the parameter used to calculate the rise of a part's junction temperature due to its power dissipation. For the LM27 the equation used to calculate the rise in the die junction temperature is as follows:

$$T_J = T_A + \theta_{JA}(V^+I_Q + (V^+ - V_{TEMP})I_{L\_TEMP} + V_{DO}I_{DO}) \quad (3)$$

where  $T_A$  is the ambient temperature,  $V^+$  is the power supply voltage,  $I_Q$  is the quiescent current,  $I_{L\_TEMP}$  is the load current on the  $V_{TEMP}$  output,  $V_{DO}$  is the voltage on the digital output, and  $I_{DO}$  is the load current on the digital output. Since the LM27's junction temperature is the actual temperature being measured, care should be taken to minimize the load current that the LM27 is required to drive.

The tables shown in Figure 3 summarize the thermal resistance for different conditions and the rise in die temperature of the LM27 without any loading on  $V_{TEMP}$  and a 10k pull-up resistor on an open-drain digital output with a 5.5V power supply.

	SOT23-5 no heat sink		SOT23-5 small heat sink	
	$\theta_{JA}$ ( $^\circ\text{C}/\text{W}$ )	$T_J - T_A$ ( $^\circ\text{C}$ )	$\theta_{JA}$ ( $^\circ\text{C}/\text{W}$ )	$T_J - T_A$ ( $^\circ\text{C}$ )
Still Air	250	0.11	TBD	TBD
Moving Air	TBD	TBD	TBD	TBD

**FIGURE 3. Thermal resistance ( $\theta_{JA}$ ) and temperature rise due to self heating ( $T_J - T_A$ )**

# Typical Applications

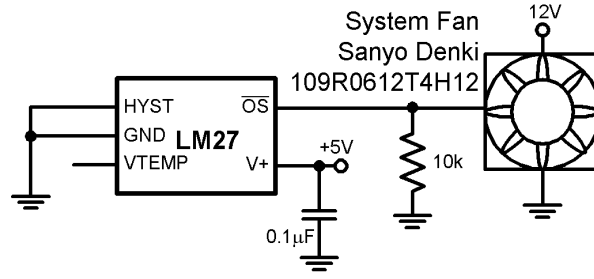

20030703

Note: The fan's control pin has internal pull-up. The 10k pull-down sets a slow fan speed. When the output of the LM27 goes low, the fan will speed up.

FIGURE 4. Two Speed Fan Speed Control

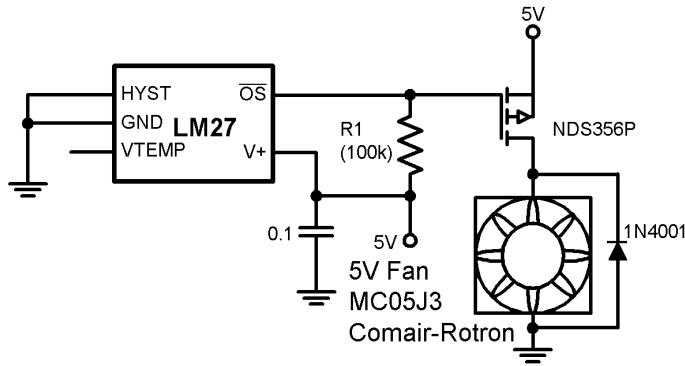

20030720

FIGURE 5. Fan High Side Drive

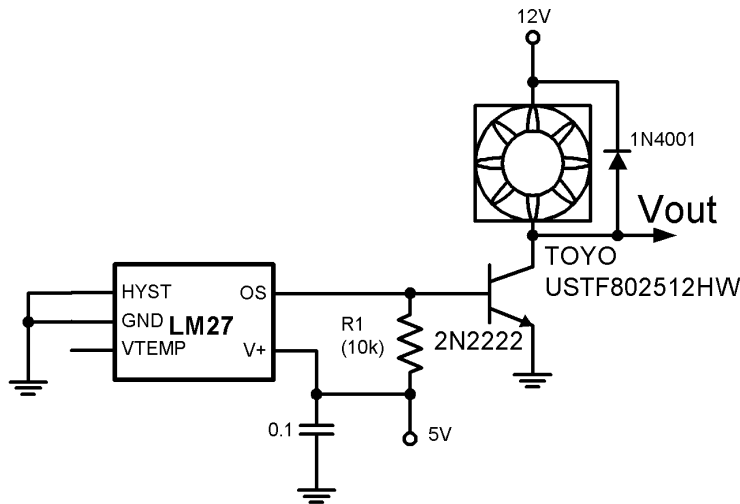

20030721

FIGURE 6. Fan Low Side Drive

Typical Applications (Continued)

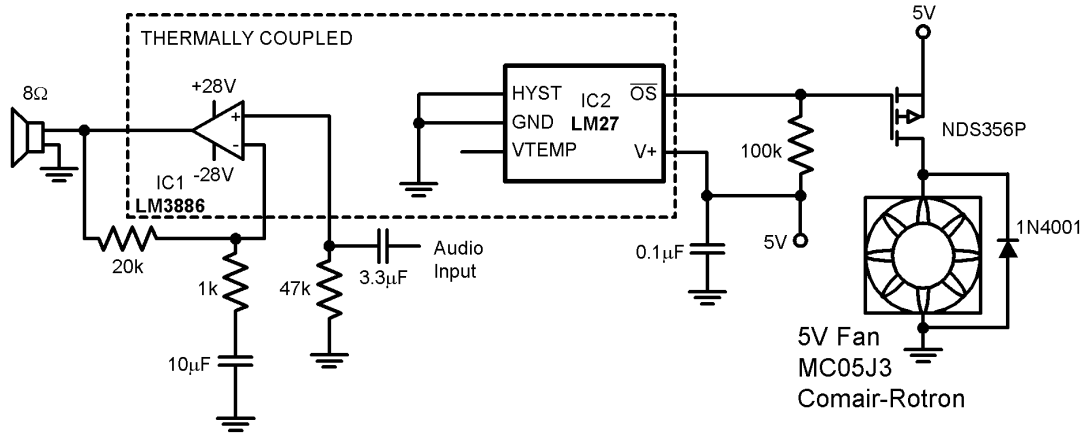

20030722

FIGURE 7. Audio Power Amplifier Thermal Protection

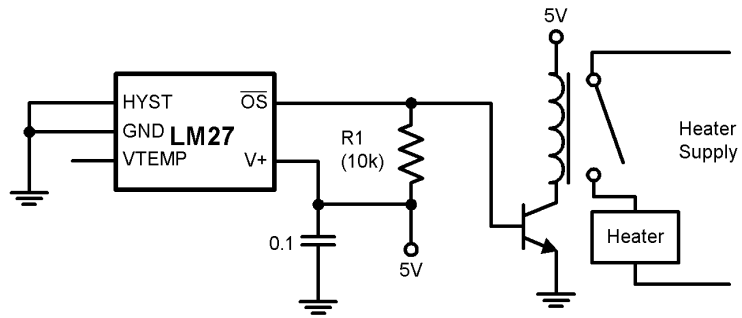

20030723

FIGURE 8. Simple Thermostat



**Physical Dimensions** inches (millimeters) unless otherwise noted

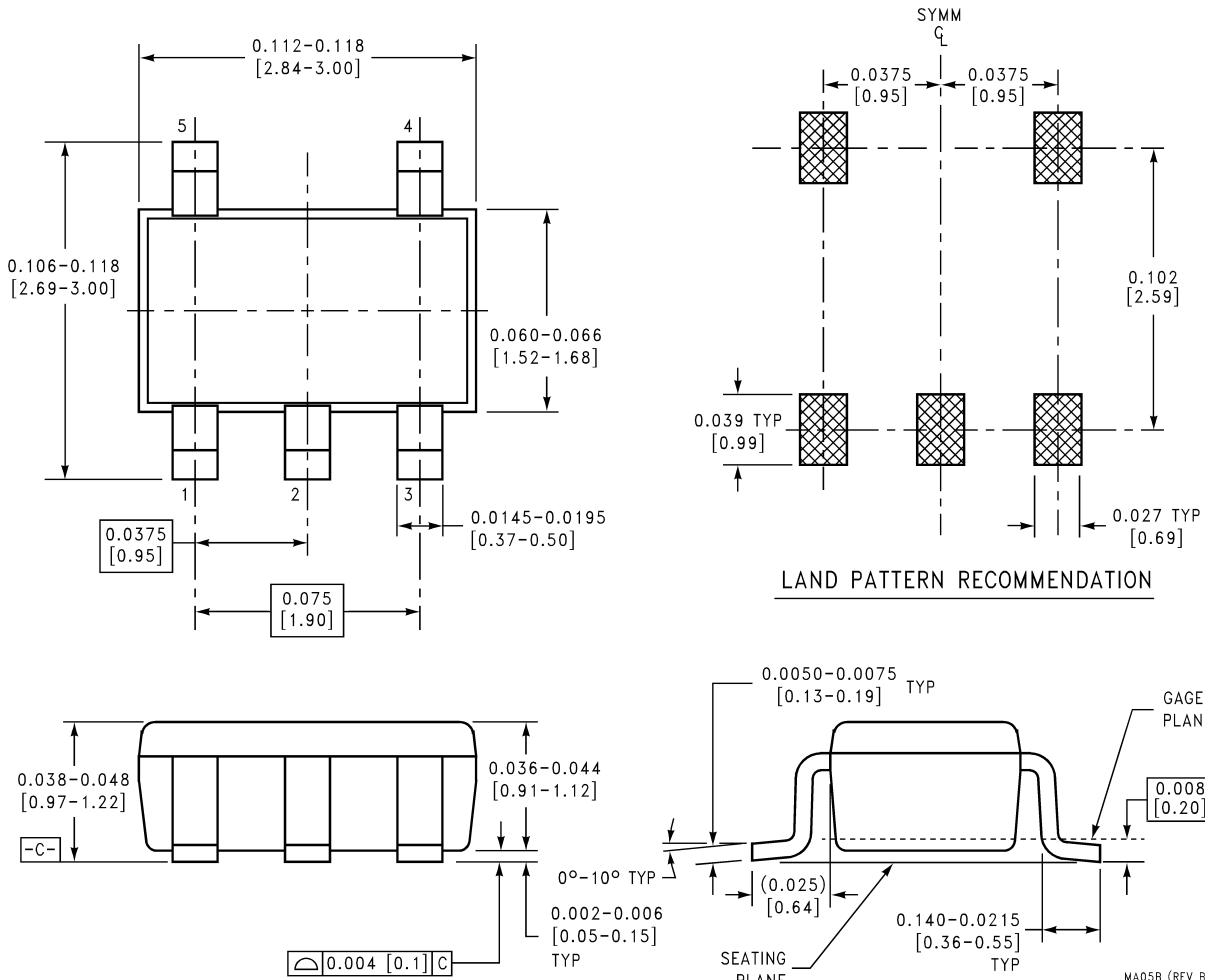

**5-Lead Molded SOT-23 Plastic Package, JEDEC**  
**Order Number LM27CIM5 or LM27CIM5X**  
**NS Package Number MA05B**

National does not assume any responsibility for use of any circuitry described, no circuit patent licenses are implied and National reserves the right at any time without notice to change said circuitry and specifications.

For the most current product information visit us at [www.national.com](http://www.national.com).

**LIFE SUPPORT POLICY**

NATIONAL'S PRODUCTS ARE NOT AUTHORIZED FOR USE AS CRITICAL COMPONENTS IN LIFE SUPPORT DEVICES OR SYSTEMS WITHOUT THE EXPRESS WRITTEN APPROVAL OF THE PRESIDENT AND GENERAL COUNSEL OF NATIONAL SEMICONDUCTOR CORPORATION. As used herein:

1. Life support devices or systems are devices or systems which, (a) are intended for surgical implant into the body, or (b) support or sustain life, and whose failure to perform when properly used in accordance with instructions for use provided in the labeling, can be reasonably expected to result in a significant injury to the user.
2. A critical component is any component of a life support device or system whose failure to perform can be reasonably expected to cause the failure of the life support device or system, or to affect its safety or effectiveness.

**BANNED SUBSTANCE COMPLIANCE**

National Semiconductor follows the provisions of the Product Stewardship Guide for Customers (CSP-9-111C2) and Banned Substances and Materials of Interest Specification (CSP-9-111S2) for regulatory environmental compliance. Details may be found at: [www.national.com/quality/green](http://www.national.com/quality/green).

Lead free products are RoHS compliant.



**National Semiconductor**  
**Americas Customer Support Center**  
 Email: [new.feedback@nsc.com](mailto:new.feedback@nsc.com)  
 Tel: 1-800-272-9959

**National Semiconductor**  
**Europe Customer Support Center**  
 Fax: +49 (0) 180-530 85 86  
 Email: [europe.support@nsc.com](mailto:europe.support@nsc.com)  
 Deutsch Tel: +49 (0) 69 9508 6208  
 English Tel: +44 (0) 870 24 0 2171  
 Français Tel: +33 (0) 1 41 91 8790

**National Semiconductor**  
**Asia Pacific Customer Support Center**  
 Email: [ap.support@nsc.com](mailto:ap.support@nsc.com)

**National Semiconductor**  
**Japan Customer Support Center**  
 Fax: 81-3-5639-7507  
 Email: [jpn.feedback@nsc.com](mailto:jpn.feedback@nsc.com)

**LM27 SOT-23,  $\pm 3^{\circ}\text{C}$  Accurate,  $120^{\circ}\text{C}$ - $150^{\circ}\text{C}$  Factory Preset Thermostat**