

LM185/LM285/LM385

Adjustable Micropower Voltage References

General Description

The LM185/LM285/LM385 are micropower 3-terminal adjustable band-gap voltage reference diodes. Operating from 1.24 to 5.3V and over a 10 μA to 20 mA current range, they feature exceptionally low dynamic impedance and good temperature stability. On-chip trimming is used to provide tight voltage tolerance. Since the LM185 band-gap reference uses only transistors and resistors, low noise and good long-term stability result.

Careful design of the LM185 has made the device tolerant of capacitive loading, making it easy to use in almost any reference application. The wide dynamic operating range allows its use with widely varying supplies with excellent regulation.

The extremely low power drain of the LM185 makes it useful for micropower circuitry. This voltage reference can be used to make portable meters, regulators or general purpose an-

alog circuitry with battery life approaching shelf life. Further, the wide operating current allows it to replace older references with a tighter tolerance part.

The LM185 is rated for operation over a -55°C to 125°C temperature range, while the LM285 is rated -40°C to 85°C and the LM385 0°C to 70°C . The LM185 is available in a hermetic TO-46 package and the LM285/LM385 are available in a low-cost TO-92 molded package, as well as S.O.

Features

- Adjustable from 1.24V to 5.30V
- Operating current of 10 μA to 20 mA
- 1% and 2% initial tolerance
- 1 Ω dynamic impedance
- Low temperature coefficient

Connection Diagrams

**TO-92
Plastic Package**

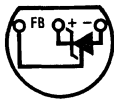

Bottom View

TL/H/5250-9

Order Number LM285BXZ,
LM285BYZ, LM285Z, LM385BXZ,
LM385BYZ or LM385Z
See NS Package Number Z03A

**TO-46
Metal Can Package**

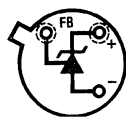

Bottom View

TL/H/5250-1

Order Number LM185BH,
LM185BXH or LM185BYH
See NS Package Number H03A

SO Package

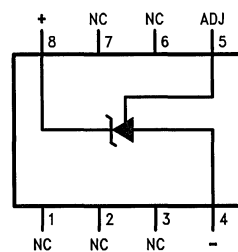

TL/H/5250-10

Order Number LM285M or LM385M
See NS Package Number M08A

Block Diagram

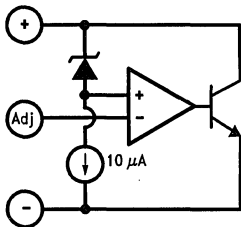

TL/H/5250-13

Typical Applications

1.2V Reference

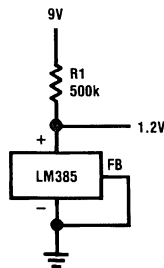

TL/H/5250-14

5.0V Reference

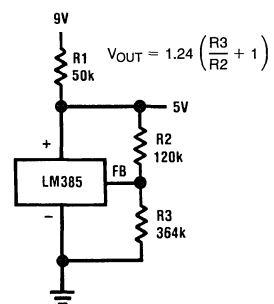

TL/H/5250-2

Absolute Maximum Ratings (Note 1)

If Military/Aerospace specified devices are required, please contact the National Semiconductor Sales Office/Distributors for availability and specifications.

(Note 2)

Reverse Current	30 mA
Forward Current	10 mA
Operating Temperature Range (Note 3)	
LM185 Series	-55°C to 125°C
LM285 Series	-40°C to 85°C
LM385 Series	0°C to 70°C
Storage Temperature	-55°C to 150°C

Soldering Information

TO-92 Package (10 sec.)	260°C
TO-46 Package (10 sec.)	300°C
SO Package	
Vapor Phase (60 sec.)	215°C
Infrared (15 sec.)	220°C

See An-450 "Surface Mounting Methods and Their Effect on Product Reliability" for other methods of soldering surface mount devices.

Electrical Characteristics (Note 4)

Parameter	Conditions	LM185, LM285						LM385				Units (Limit)	
		Typ	LM185BX, LM185BY LM185B, LM285BX, LM285BY			LM285		Typ	LM385BX, LM385BY		LM385		
			Tested Limit (Note 5)	Design Limit (Note 6)	Tested Limit (Note 5)	Design Limit (Note 6)	Tested Limit (Note 5)		Design Limit (Note 6)	Tested Limit (Note 5)	Design Limit (Note 6)		
Reference Voltage	$I_R = 100 \mu\text{A}$	1.240	1.252 1.255 1.228 1.215		1.265 1.270	1.215 1.205	1.240	1.252 1.255	1.265 1.270	1.265 1.270	1.215 1.205	V (max) V (min)	
Reference Voltage Change with Current	$I_{\text{MIN}} < I_R < 1 \text{ mA}$ $1 \text{ mA} < I_R < 20 \text{ mA}$	0.2 4	1 10	1.5 20	1 10	1.5 20	0.2 5	1 15	1.5 25	1 15	1.5 25	mV (max)	
Dynamic Output Impedance	$I_R = 100 \mu\text{A}$, $f = 100 \text{ Hz}$ $I_{\text{AC}} = 0.1 I_R$ $V_{\text{OUT}} = V_{\text{REF}}$ $V_{\text{OUT}} = 5.3\text{V}$	0.3 0.7					0.4 1					Ω	
Reference Voltage Change with Output Voltage	$I_R = 100 \mu\text{A}$	1	3	6	3	6	2	5	10	5	10	mV (max)	
Feedback Current		13	20	25	20	25	16	30	35	30	35	nA (max)	
Minimum Operating Current (see curve)	$V_{\text{OUT}} = V_{\text{REF}}$ $V_{\text{OUT}} = 5.3\text{V}$	6 30	9 45	10 50	9 45	10 50	7 35	11 55	13 60	11 55	13 60	μA (max)	
Output Wideband Noise	$I_R = 100 \mu\text{A}$, $10 \text{ Hz} < f < 10 \text{ kHz}$ $V_{\text{OUT}} = V_{\text{REF}}$ $V_{\text{OUT}} = 5.3\text{V}$	50 170					50 170					μV_{rms}	
Average Temperature Coefficient (Note 7)	$I_R = 100 \mu\text{A}$ X Suffix Y Suffix All Others		30 50		30 50	150 150		30 50		30 50	150 150	ppm/°C (max)	
Long Term Stability	$I_R = 100 \mu\text{A}$, $T = 1000 \text{ Hr}$, $T_A = 25^\circ\text{C} \pm 0.1^\circ\text{C}$	20					20					ppm	

Note 1: Absolute Maximum Ratings indicate limits beyond which damage to the device may occur. Operating Ratings indicate conditions for which the device is intended to be functional, but do not guarantee specific performance limits. For guaranteed specifications and test conditions, see the Electrical Characteristics. The guaranteed specifications apply only for the test conditions listed.

Note 2: Refer to RETS185H for military specifications.

Note 3: For elevated temperature operation, T_J max is:

LM185	150°C
LM285	125°C
LM385	100°C

Thermal Resistance	TO-92	TO-46	SO-8
θ_{ja} (Junction to Ambient)	180°C/W (0.4" leads) 170°C/W (0.125" leads)	440°C/W	165°C/W
θ_{jc} (Junction to Case)	N/A	80°C/W	N/A

Note 4: Parameters identified with **boldface type** apply at temperature extremes. All other numbers apply at $T_A = T_J = 25^\circ\text{C}$. Unless otherwise specified, all parameters apply for $V_{\text{REF}} < V_{\text{OUT}} < 5.3\text{V}$.

Note 5: Guaranteed and 100% production tested.

Note 6: Guaranteed, but not 100% production tested. These limits are not to be used to calculate average outgoing quality levels.

Note 7: The average temperature coefficient is defined as the maximum deviation of reference voltage at all measured temperatures from T_{min} to T_{max} , divided by $T_{\text{max}} - T_{\text{min}}$. The measured temperatures are -55, -40, 0, 25, 70, 85, 125°C.

Typical Performance Characteristics

Temperature Drift of 3 Representative Units

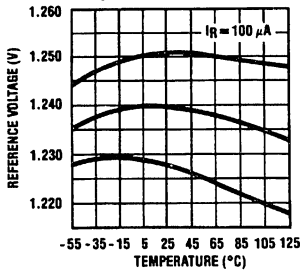

Feedback Current

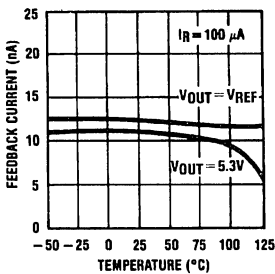

Minimum Operating Current

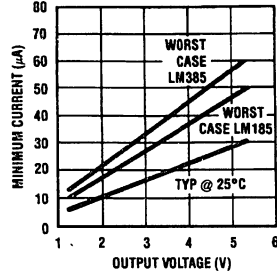

Reverse Characteristics

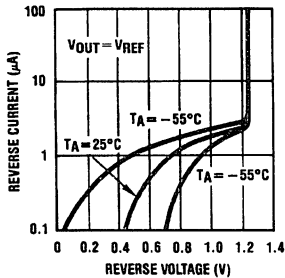

Reverse Characteristics

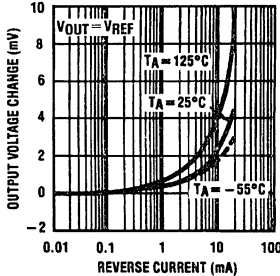

Forward Characteristics

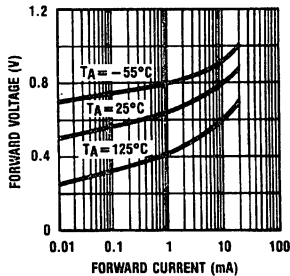

Output Noise Voltage

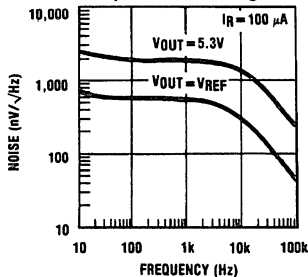

Dynamic Output Impedance

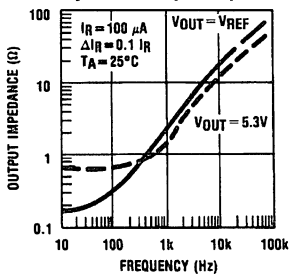

Response Time

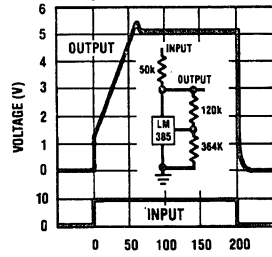

TL/H/5250-3

LM185 Temperature Coefficient Typical

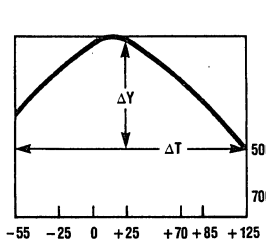

LM285 Temperature Coefficient Typical

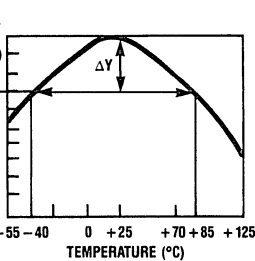

LM385 Temperature Coefficient Typical

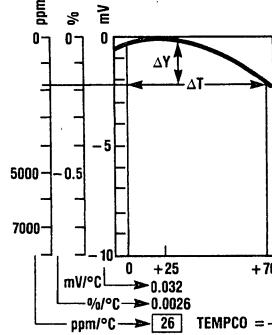

0.035 mV/°C
0.0028 %/°C
28 ppm/°C

0.025 mV/°C
0.002 %/°C
20 ppm/°C

TEMPCO = $\frac{\text{TOTAL } \Delta Y \text{ IN ppm}}{\text{TOTAL } \Delta T}$

TL/H/5250-4

Typical Applications (Continued)

Precision 10V Reference

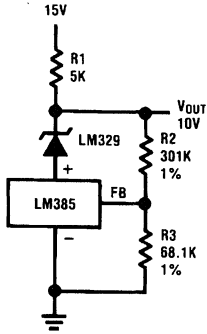

Low AC Noise Reference

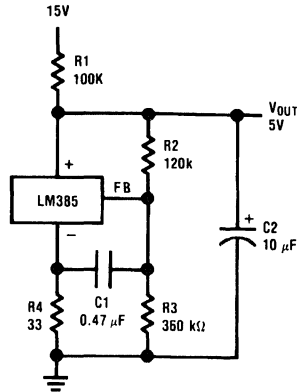

25V Low Current Shunt Regulator

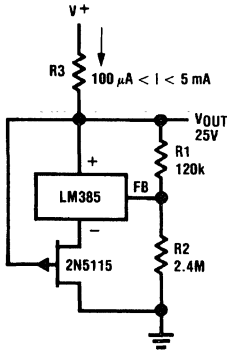

200 mA Shunt Regulator

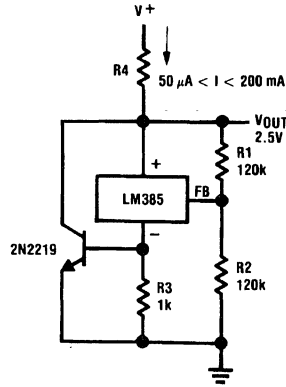

Series-Shunt 20 mA Regulator

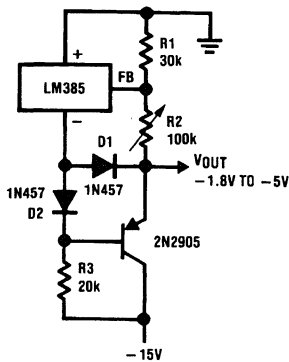

High Efficiency Low Power Regulator

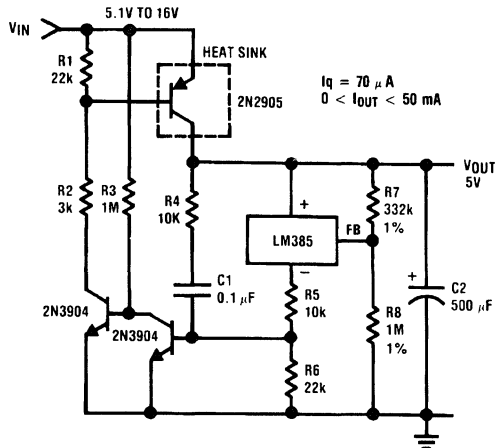

Typical Applications (Continued)

Voltage Level Detector

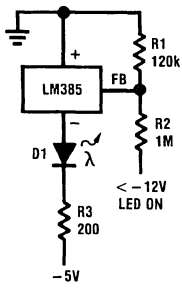

Voltage Level Detector

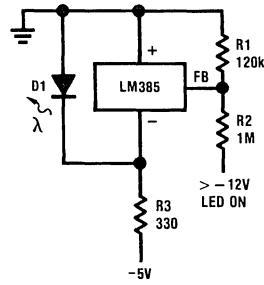

Fast Positive Clamp
 $2.4V + \Delta V_{D1}$

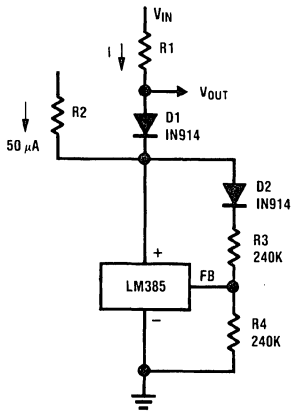

Bidirectional Clamp
 $\pm 2.4V$

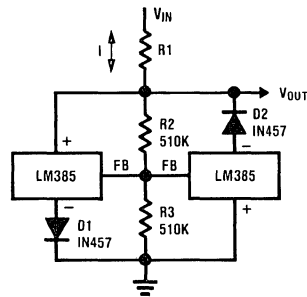

Bidirectional Adjustable Clamp
 $\pm 1.8V$ to $\pm 2.4V$

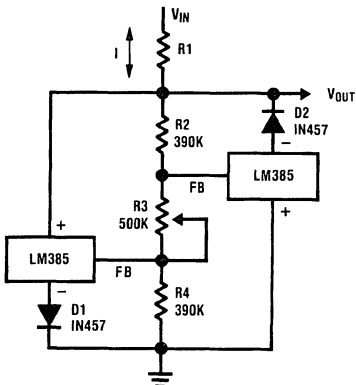

Bidirectional Adjustable Clamp
 $\pm 2.4V$ to $\pm 6V$

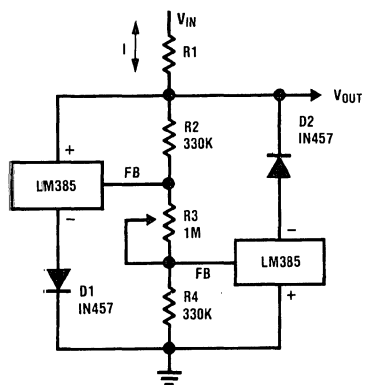

Typical Applications (Continued)

Simple Floating Current Detector

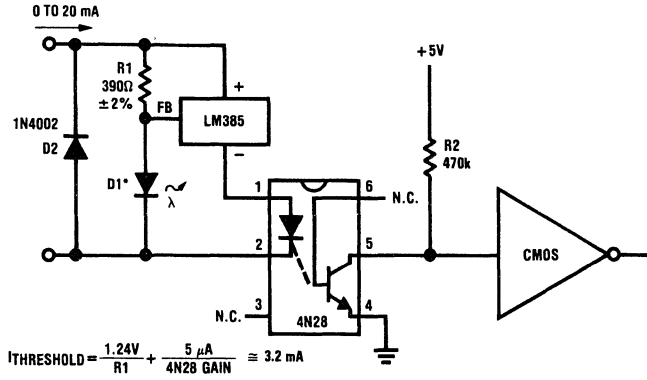

Current Source

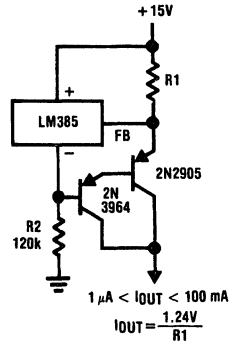

Precision Floating Current Detector

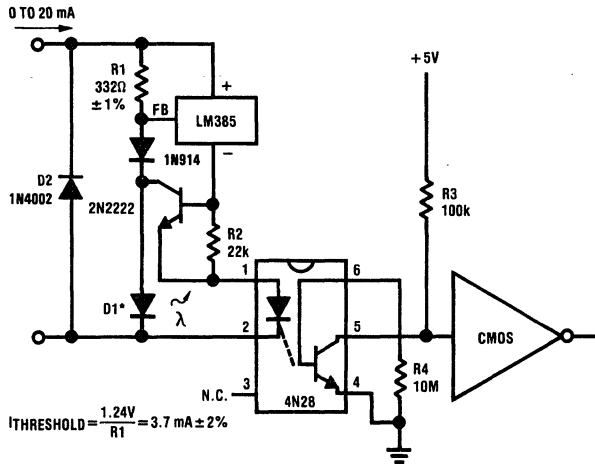

* D1 can be any LED, $V_F = 1.5V$ to $2.2V$ at 3 mA . D1 may act as an indicator. D1 will be on if $I_{THRESHOLD}$ falls below the threshold current, except with $I = 0$.

TL/H/5250-7

Typical Applications (Continued)

Centigrade Thermometer, 10 mV/°C

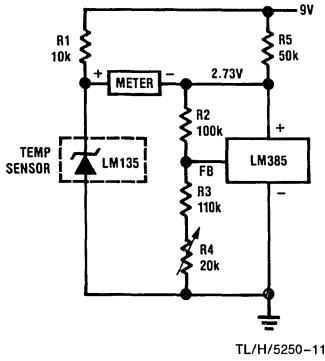

Freezer Alarm

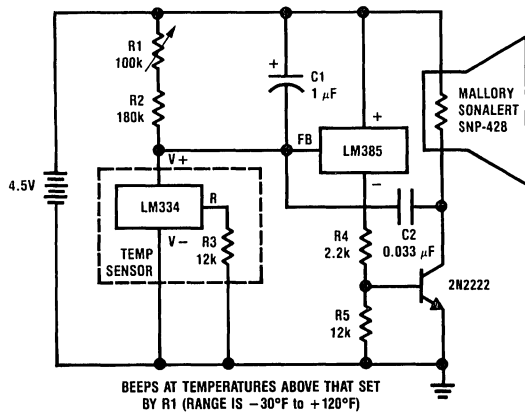

Schematic Diagram

