

Product Specification

SPECIFICATION

FOR

APPROVAL

Preliminary Specification
 Final Specification

Title	29" Wide Full HD TFT LCD
-------	--------------------------

BUYER	General
MODEL	

SUPPLIER	LG Display Co., Ltd.
*MODEL	LM290WW1
SUFFIX	SSZ1

*When you obtain standard approval,
please use the above model name without suffix

APPROVED BY	SIGNATURE DATE
/	_____
/	_____
/	_____

APPROVED BY	SIGNATURE DATE
C. K. Lee / G. Manager	_____
REVIEWED BY	
B. C. Kim / Manager [C]	_____
K. H. Moon / Manager [M]	_____
J. K. Lee / Manager [P]	_____
PREPARED BY	
M. L. Yoon / Engineer	_____

Please return 1 copy for your confirmation with your signature and comments.

IT/Mobile Development Division 1
LG Display Co., Ltd

Product Specification
Contents

No	ITEM	Page
	COVER	1
	CONTENTS	2
	RECORD OF REVISIONS	3
1	GENERAL DESCRIPTION	4
2	ABSOLUTE MAXIMUM RATINGS	5
3	ELECTRICAL SPECIFICATIONS	6
3-1	ELECTRICAL CHARACTERISTICS	6
3-2	INTERFACE CONNECTIONS	9
3-3	LVDS CHARACTERISTICS	13
3-4	SIGNAL TIMING SPECIFICATIONS	18
3-5	SIGNAL TIMING WAVEFORMS	19
3-6	COLOR DATA REFERENCE	20
3-7	POWER SEQUENCE	21
4	OPTICAL SPECIFICATIONS	23
5	MECHANICAL CHARACTERISTICS	29
6	RELIABILITY	32
7	INTERNATIONAL STANDARDS	33
7-1	SAFETY	33
7-2	EMC	33
7-3	ENVIRONMENT	33
8	PACKING	34
8-1	DESIGNATION OF LOT MARK	34
8-2	PACKING FORM	34
9	PRECAUTIONS	35

Product Specification

1. General Description

LM290WW1-SSZ1 is a Color Active Matrix Liquid Crystal Display Light Emitting Diode (White LED) backlight system without LED driver. The matrix employs a-Si Thin Film Transistor as the active element.

It is a transmissive type display operating in the normally black mode. It has a 29-inch diagonally measured active display area with Wide Full HD resolution (1080 vertical by 2560 horizontal pixel array). Each pixel is divided into Red, Green and Blue sub-pixels or dots which are arranged in vertical stripes. Gray scale or the brightness of the sub-pixel color is determined with a 8-bit gray scale signal for each dot, thus, presenting a palette of more than 16,7M(True) colors. It has been designed to apply the 8Bit 4 port LVDS interface. It is intended to support applications where thin thickness, wide viewing angle, low power are critical factors and graphic displays are important. It is intended to support displays where high brightness, super wide viewing angle, high color saturation, and high color are important.

FIG. 1 Block diagram

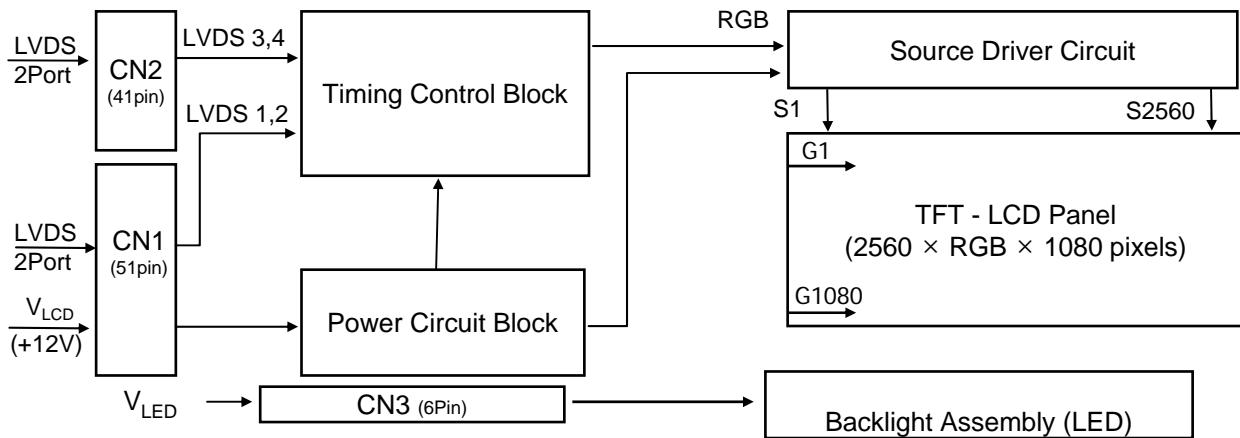

General Features

Active Screen Size	29 inches (73.025cm) diagonal (Aspect ratio 21:9)
Outline Dimension	693.6(H) x 308.9(V) x 17(D, Top : 11.1) mm (Typ.)
Pixel Pitch	0.0876(H) mm x RGB x 0.2628(V) mm
Pixel Format	2560 horizontal x 1080 vertical Pixels, RGB stripe arrangement
Color Depth	8-bit, 16,777,216 colors
Luminance, White	300 cd/m ² (Center, 1 point)
Viewing Angle (CR>10)	View Angle Free (R/L 178(Typ.), U/D 178(Typ.))
3D Viewing Angle(3DCT<10)	U+D 12° (Typ.)
3D C/T (within viewing cone min.)	≤ 1.3% (Typ.)
3D Brightness (Glass trans. 00%)	≥ 95nit (Typ.)
Power Consumption	Total 31.7W (Typ.) (6.0 W @ VLCD, 25.7 W @ 300 cd/m ²)
Weight	3,450 g (Typ.)
Display Operating Mode	Transmissive mode, Normally Black
Surface Treatment	Low Haze & CLR treatment of the front polarizer

Product Specification

2. Absolute Maximum Ratings

The following are maximum values which, if exceeded, may cause faulty operation or damage to the unit.

Table 1. Absolute maximum ratings

Parameter	Symbol	Values		Units	Notes
		Min	Max		
Power Supply Input Voltage	V_{LCD}	-0.3	+13.0	Vdc	At 25°C
Operating Temperature	T_{OP}	0	50	°C	1,2,3
Storage Temperature	T_{ST}	-20	60	°C	
Operating Ambient Humidity	H_{OP}	10	90	%RH	
Storage Humidity	H_{ST}	10	90	%RH	
LCM Surface Temperature (Operation)	$T_{surface}$	0	65	°C	1, 4

- Note : 1. Temperature and relative humidity range are shown in the figure below.
 Wet bulb temperature should be 39 °C Max, and no condensation of water.
 2. Maximum Storage Humidity is up to 40 °C, 70% RH only for 4 corner light leakage Mura.
 3. Storage condition is guaranteed under packing condition.
 4. LCM Surface Temperature should be Min. 0 °C and Max. 65 °C under the VLCD=12.0V, fV=60Hz, 25 °C ambient Temp. no humidity control and LED string current is typical value.

FIG. 2 Temperature and relative humidity

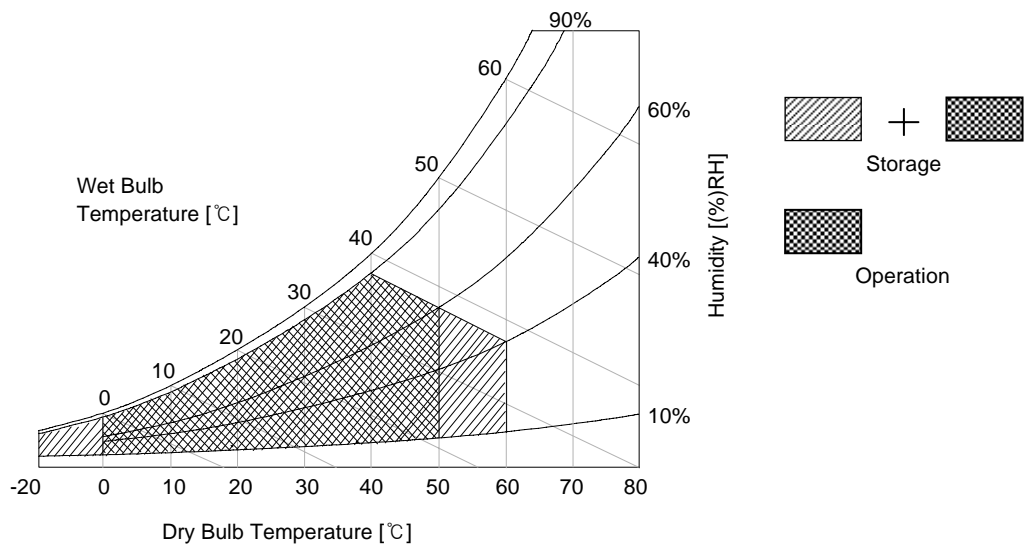

Product Specification
3. Electrical Specifications
3-1. Electrical Characteristics

It requires two power inputs. One is employed to power the LCD electronics and to drive the TFT array and liquid crystal. The other input power for the LED/Backlight is typically generated by a LED Driver. The LED Driver. is an external unit to the LCDs.

Table 2. Electrical Characteristics (Module)

Parameter	Symbol	Values			Unit	Notes
		Min	Typ	Max		
MODULE :						
Power Supply Input Voltage	V _{LCD}	11.4	12	12.6	Vdc	
Permissive Power Input Ripple	V _{LCD}	-	-	0.3	V	1
Power Supply Input Current	I _{LCD}	375	500	625	mA	2
		-	640	800	mA	3
Power Consumption	P _{LCD}	-	6.0	7.5	Watt	2
Inrush current	I _{RUSH}	-	-	2.5	A	4

Note :

1. Permissive power ripple should be measured under $V_{LCD}=12.0V$, $25^{\circ}C$, $fV(\text{frame frequency})=\text{MAX}$ condition and At that time, we recommend the bandwidth configuration of oscilloscope is to be under 20MHz. See the next page.
2. The specified current and power consumption are under the $V_{LCD}=12.0V$, $25 \pm 2^{\circ}C$, $fV=60Hz$ condition whereas Typical Power Pattern [Mosaic] shown in the [Figure 3] is displayed.
3. The current is specified at the maximum current pattern of [Figure 3].
4. Maximum Condition of Inrush current :
The duration of rush current is about 5ms and rising time of power Input is $500\mu s \pm 20\%(\text{min.})$.

Product Specification

- Permissive Power input ripple ($V_{LCD} = 12.0V$, $25^{\circ}C$, f_V (frame frequency)=MAX condition)

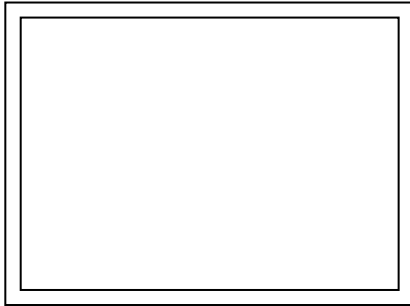

White pattern

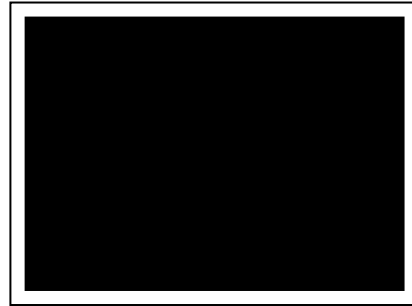

Black pattern

- Power consumption ($V_{LCD} = 12V$, $25^{\circ}C$, f_V (frame frequency)=60Hz condition)

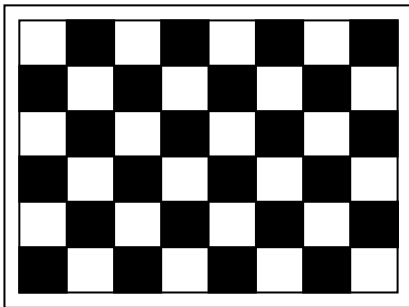

Typical power Pattern

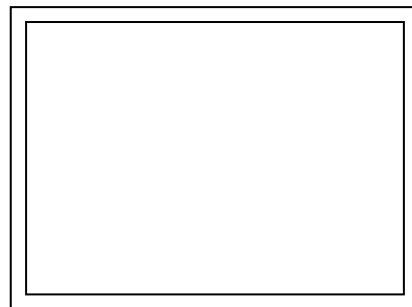

Maximum power Pattern

FIG.3 Mosaic pattern & White Pattern for power consumption measurement

Product Specification
Table 3. Electrical Characteristics (Backlight System)

Parameter	Symbol	Values			Unit	Notes
		Min.	Typ.	Max.		
LED String Current	Is	-	120	125	mA	1, 2, 5
LED String Voltage	Vs	50.2	53.6	57.0	V	1, 5
Power Consumption	P _{Bar}	-	25.7	27.3	Watt	1, 2, 4
LED Life Time	LED_LT	30,000	-	-	Hrs	3

Notes) The LED Bar consists of 68 LED packages, 4 strings (parallel) x 17 packages (serial)

LED driver design guide

- 1) The design of the LED driver must have specifications for the LED in LCD Assembly.

The performance of the LED in LCM, for example life time or brightness, is extremely influenced by the characteristics of the LED driver.

So all the parameters of an LED driver should be carefully designed and output current should be Constant current control.

Please control feedback current of each string individually to compensate the current variation among the strings of LEDs.

When you design or order the LED driver, please make sure unwanted lighting caused by the mismatch of the LED and the LED driver (no lighting, flicker, etc) never occurs.

When you confirm it, the LCD module should be operated in the same condition as installed in your instrument.

- 2) LGD strongly recommend Analog Dimming method for Backlight Brightness control for Wavy Noise Free. Otherwise, recommend that Dimming Control Signal (PWM Signal) should be synchronized with Frame Frequency.

- The specified values are for a single LED bar.
- The specified current is defined as the input current for a single LED string with 100% duty cycle.
- The LED life time is defined as the time when brightness of LED packages become 50% or less than the initial value under the conditions at $T_a = 25 \pm 2^\circ\text{C}$ and LED string current is typical value.
- The power consumption shown above does not include loss of external driver.
The typical power consumption is calculated as $P_{\text{Bar}} = V_s(\text{Typ.}) \times I_s(\text{Typ.}) \times \text{No. of strings}$.
The maximum power consumption is calculated as $P_{\text{Bar}} = V_s(\text{Max.}) \times I_s(\text{Typ.}) \times \text{No. of strings}$.
- LED operating conditions are must not exceed Max. ratings.

Product Specification
3-2. Interface Connections

This LCD module employs two kinds of interface connection, 51 pin connector and 41 pin connector are used for the module electronics.

3-2-1. LCD Module
Table 4. Module Connector (CN1) Pin Configuration

- LCD Connector(CN1): GT05P-51S-H38-E1500 (manufactured by LSM) or equivalent
- Mating Connector : FI-RE51HL(JAE) or equivalent

No	Symbol	Description	No	Symbol	Description
1	GND	Ground	27	Reserved	No connection or GND
2	NC	No Connection	28	R2AN	2nd LVDS Channel Signal (A-)
3	NC	No Connection	29	R2AP	2nd LVDS Channel Signal (A+)
4	NC	LGD internal use for I2C	30	R2BN	2nd LVDS Channel Signal (B-)
5	NC	LGD internal use for I2C	31	R2BP	2nd LVDS Channel Signal (B+)
6	NC	No Connection	32	R2CN	2nd LVDS Channel Signal (C-)
7	PBP Select	'H'= PBP Concept , 'L'=normal	33	R2CP	2nd LVDS Channel Signal (C+)
8	NC	No Connection	34	GND	Ground
9	NC	No Connection	35	R2CLKN	2nd LVDS Channel Clock Signal(-)
10	PWM_OUT	Reference signal for LED dimming control	36	R2CLKP	2nd LVDS Channel Clock Signal(+)
11	GND	Ground	37	GND	Ground
12	R1AN	1st LVDS Channel Signal (A-)	38	R2DN	2nd LVDS Channel Signal (D-)
13	R1AP	1st LVDS Channel Signal (A+)	39	R2DP	2nd LVDS Channel Signal (D+)
14	R1BN	1st LVDS Channel Signal (B-)	40	NC	No Connection
15	R1BP	1st LVDS Channel Signal (B+)	41	NC	No Connection
16	R1CN	1st LVDS Channel Signal (C-)	42	Reserved	No connection or GND
17	R1CP	1st LVDS Channel Signal (C+)	43	GND	Ground
18	GND	Ground	44	GND	Ground (AGP)
19	R1CLKN	1st LVDS Channel Clock Signal(-)	45	GND	Ground
20	R1CLKP	1st LVDS Channel Clock Signal(+)	46	GND	Ground
21	GND	Ground	47	NC	No connection
22	R1DN	1st LVDS Channel Signal (D-)	48	VLCD	Power Supply +12.0V
23	R1DP	1st LVDS Channel Signal (D+)	49	VLCD	Power Supply +12.0V
24	NC	No Connection	50	VLCD	Power Supply +12.0V
25	NC	No Connection	51	VLCD	Power Supply +12.0V
26	Reserved	No connection or GND			

Note : PBP = Picture By Picture

Product Specification**Note :**

1. All GND (Ground) pins should be connected together to the LCD module's metal frame.
2. All V_{LCD} (power input) pins should be connected together.
3. All Input levels of LVDS signals are based on the EIA 664 Standard.
4. Always all LVDS signal and clock input should be 4 channels and synchronized.
5. PWM_OUT is a reference signal for LED PWM control.

This PWM signal is synchronized with vertical frequency.

Its frequency is 3 times of vertical frequency, and its duty ratio is 50%.

If the system don't use this pin, do not connect.

Product Specification

3-2-2. Backlight system

Table 6. BACKLIGHT CONNECTOR PIN CONFIGURATION

The LED interface connector is a model SM06B-SHJH(HF), wire-locking type manufactured by JST.
The mating connector is a SHJP-06V-S(HF) or Equivalent.
The pin configuration for the connector is shown in the table below.

Pin	Symbol	Description	Notes
1	FB1	Channel1 Current Feedback	
2	FB2	Channel2 Current Feedback	
3	VLED	LED Power Supply	
4	VLED	LED Power Supply	
5	FB3	Channel3 Current Feedback	
6	FB4	Channel4 Current Feedback	

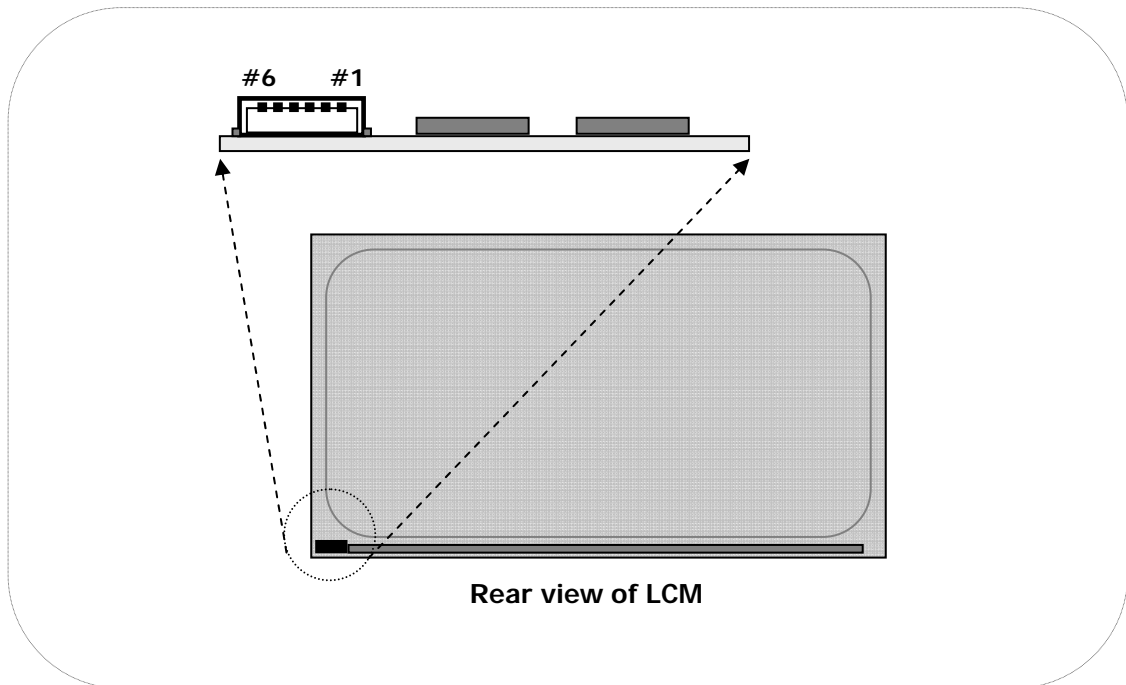

[Figure 5] Backlight connector view

Product Specification

3-3. LVDS characteristics

3-3-1. DC Specification

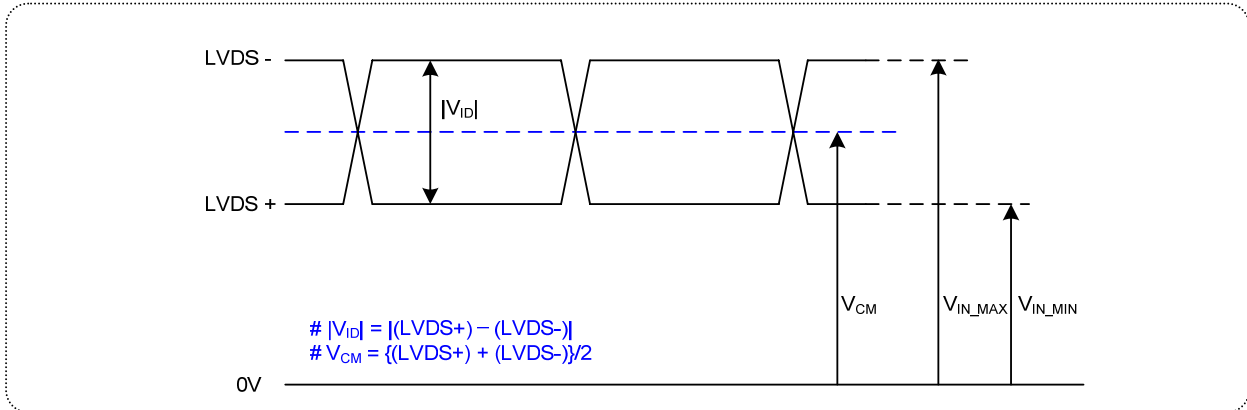

Description	Symbol	Min	Max	Unit	Notes
LVDS Differential Voltage	$ V_{ID} $	200	600	mV	-
LVDS Common mode Voltage	V_{CM}	1.0	1.5	V	-
LVDS Input Voltage Range	V_{IN}	0.7	1.8	V	-
Change in common mode Voltage	ΔV_{CM}	-	250	mV	-

3-3-2. AC Specification

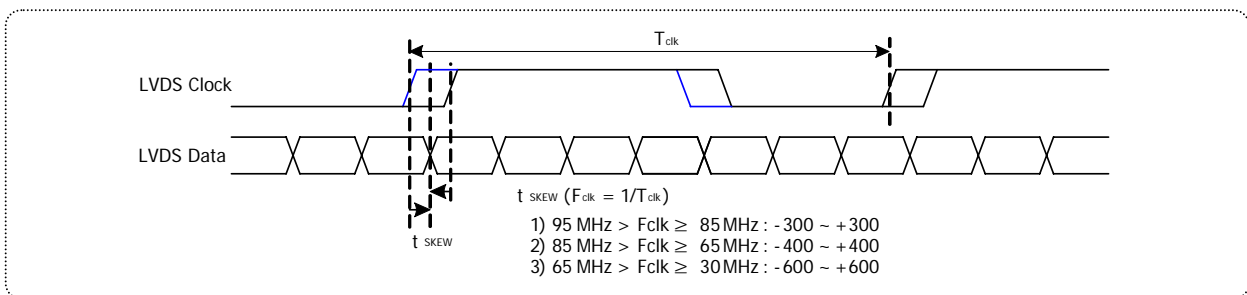

Description	Symbol	Min	Max	Unit	Notes
LVDS Clock to Data Skew Margin	t_{SKEW}	- 300	+ 300	ps	95MHz > Fclk ≥ 85MHz
	t_{SKEW}	- 400	+ 400	ps	85MHz > Fclk ≥ 65MHz
	t_{SKEW}	- 600	+ 600	ps	65MHz > Fclk ≥ 30MHz
LVDS Clock to Clock Skew Margin (Even to Odd)	t_{SKEW_EO}	- 1/7	+ 1/7	T_{clk}	-

Product Specification

3-3-3. LVDS data format (8bit, VESA)

3rd LVDS Channel

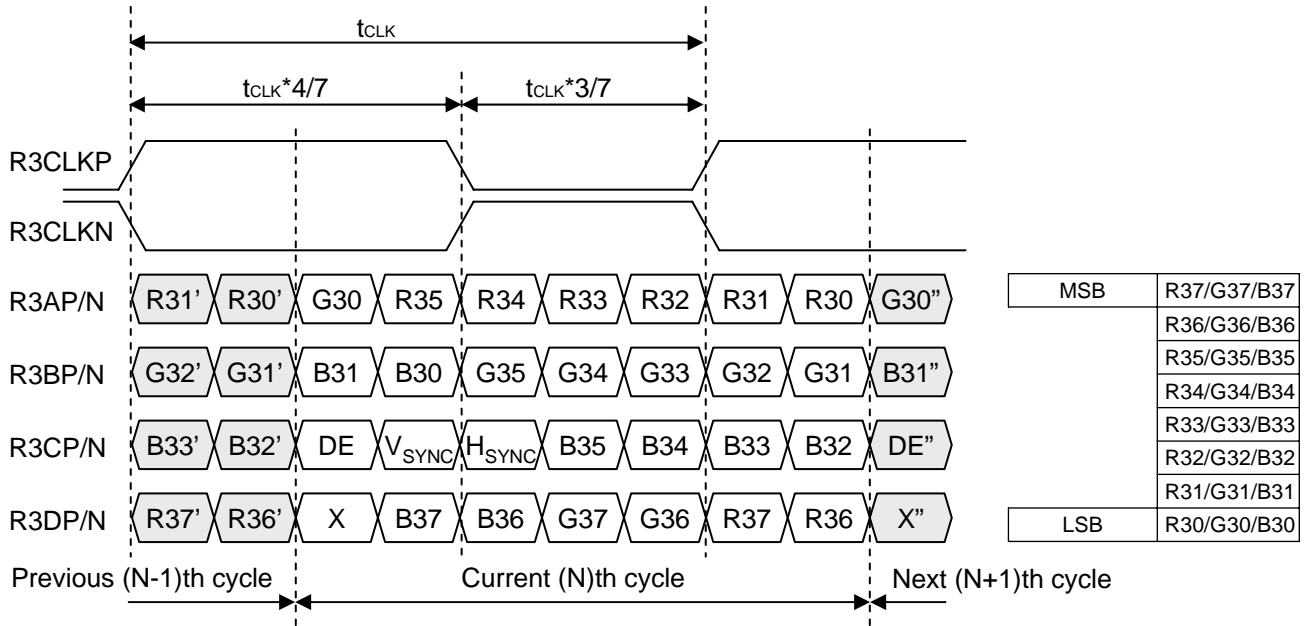

4th LVDS Channel

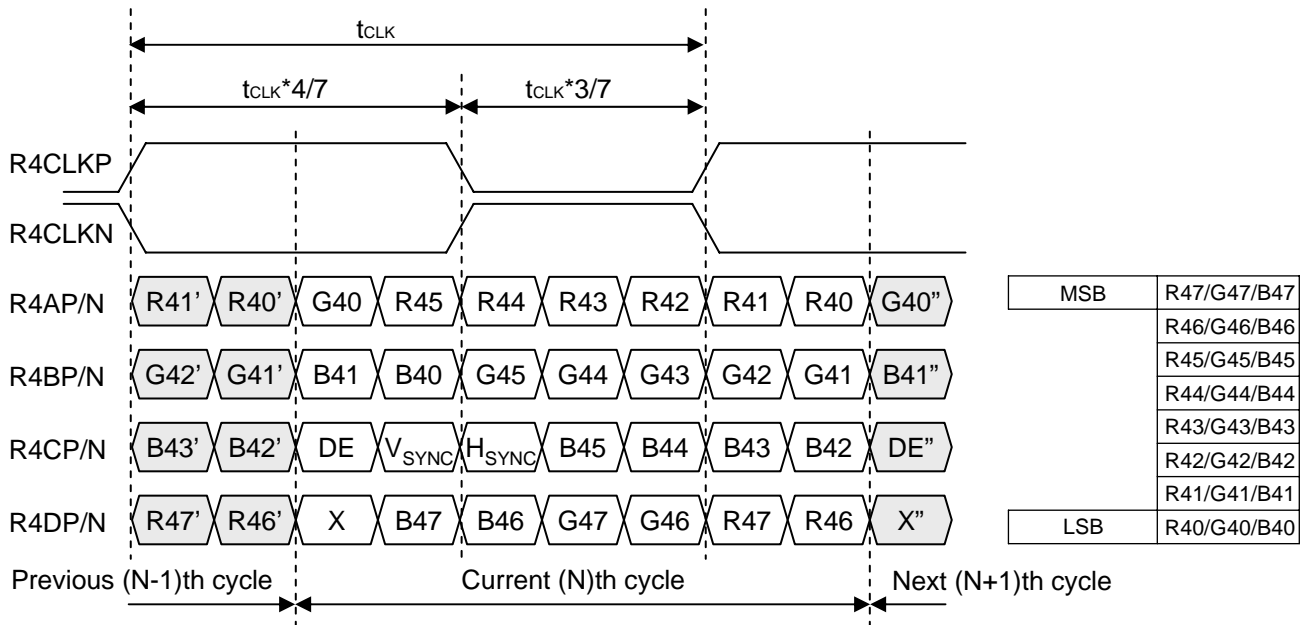

Product Specification
3-4. Signal Timing Specifications

This is signal timing required at the input of the Module connector. All of the interface signal timing should be satisfied with the following specifications for its proper operation.

Table 7 . Timing Table

Parameter		Symbol	Min.	Typ.	Max.	Unit	Notes
D_{CLK}	Period	t_{CLK}	17.2	21.6	25.9	ns	Pixel frequency : Typ. 185.58MHz
	Frequency	f_{CLK}	38.7	46.4	58.0	MHz	
Hsync	Horizontal Valid	t_{HV}	640	640	640	t_{CLK}	For D_{CLK}
	H Period Total	t_{HP}	680	696	712		
	Hsync Frequency	f_H	55.6	66.7	83.3		
Vsync	Vertical Valid	t_{VV}	1080	1080	1080	t_{HP}	
	V Period Total	t_{VP}	1093	1111	1330		
	Vsync Frequency	f_V	50	60	75		

Note : Hsync period and Hsync width-active should be even number times of t_{CLK} . If the value is odd number times of t_{CLK} , display control signal can be asynchronous. In order to operate this LCM a Hsync, Vsync, and DE(data enable) signals should be used.

1. The Input of Hsync & Vsync signal does not have an effect on normal operation (DE Only Mode).
If you use spread spectrum for EMI, add some additional clock to minimum value for clock margin.
2. The performance of the electro-optical characteristics may be influenced by variance of the vertical refresh rates.
3. Horizontal period should be even.
4. Vsync and Hsync should be keep the above specification.
5. Hsync Horizontal Valid and H Period Total should be any times of of character number(4).
6. The polarity of Hsync, Vsync is not restricted.
7. The Max frequency of 2560X1080 resolution is 58Mhz

Product Specification

3-5. Signal Timing Waveforms

1. DCLK, DE, DATA waveforms

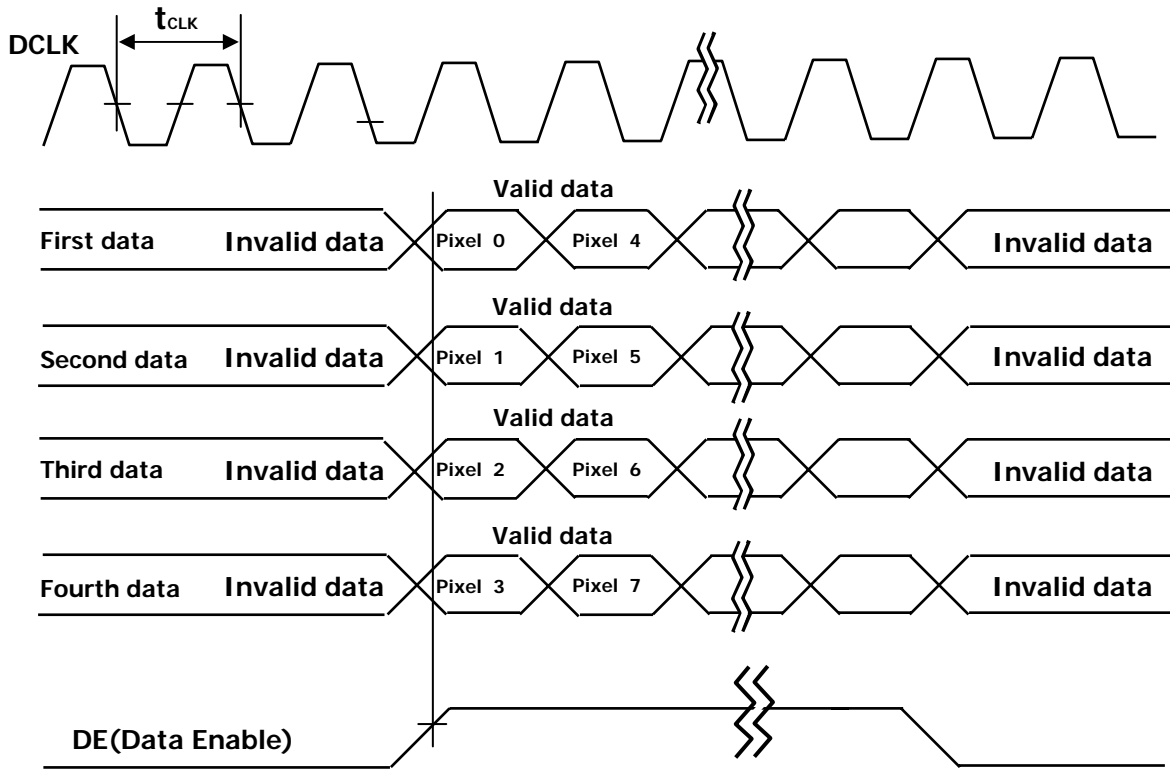

2. Horizontal waveform

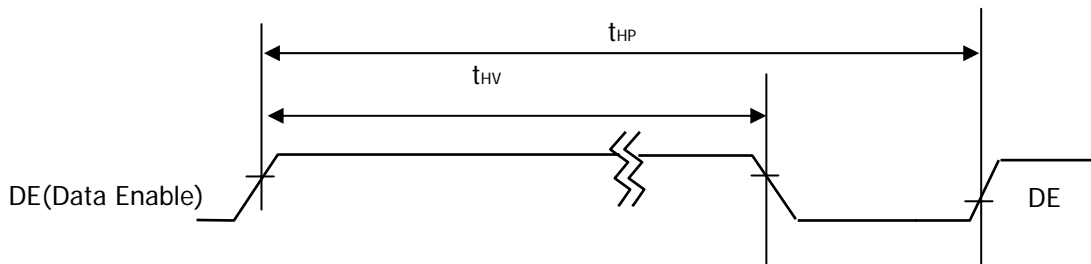

3. Vertical waveform

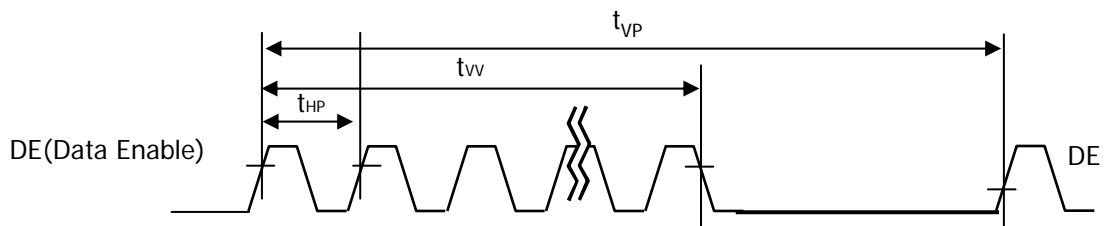

Product Specification

3-6. Color Data Reference

The Brightness of each primary color (Red, Green, Blue) is based on the 8-bit gray scale data input for the color; the higher the binary input, the brighter the color. The table below provides a reference for color versus data input.

Table 8. Color Data Reference

Color		Input Color Data																							
		Red								Green								Blue							
		MSB				LSB				MSB				LSB				MSB				LSB			
		R7	R6	R5	R4	R3	R2	R1	R0	G7	G6	G5	G4	G3	G2	G1	G0	B7	B6	B5	B4	B3	B2	B1	B0
Basic Color	Black	0	0	0	0	0	0	0	0	0	0	0	0	0	0	0	0	0	0	0	0	0	0	0	0
	Red (255)	1	1	1	1	1	1	1	1	0	0	0	0	0	0	0	0	0	0	0	0	0	0	0	0
	Green (255)	0	0	0	0	0	0	0	0	1	1	1	1	1	1	1	1	0	0	0	0	0	0	0	0
	Blue (255)	0	0	0	0	0	0	0	0	0	0	0	0	0	0	0	0	1	1	1	1	1	1	1	1
	Cyan	0	0	0	0	0	0	0	0	1	1	1	1	1	1	1	1	1	1	1	1	1	1	1	1
	Magenta	1	1	1	1	1	1	1	1	0	0	0	0	0	0	0	0	1	1	1	1	1	1	1	1
	Yellow	1	1	1	1	1	1	1	1	1	1	1	1	1	1	1	1	0	0	0	0	0	0	0	0
	White	1	1	1	1	1	1	1	1	1	1	1	1	1	1	1	1	1	1	1	1	1	1	1	1
Red	Red(000) Dark	0	0	0	0	0	0	0	0	0	0	0	0	0	0	0	0	0	0	0	0	0	0	0	0
	Red(001)	0	0	0	0	0	0	0	1	0	0	0	0	0	0	0	0	0	0	0	0	0	0	0	0
	Red(002)	0	0	0	0	0	0	1	0	0	0	0	0	0	0	0	0	0	0	0	0	0	0	0	0
	-----	-	-	-	-	-	-	-	-	-	-	-	-	-	-	-	-	-	-	-	-	-	-	-	-
	-----	-	-	-	-	-	-	-	-	-	-	-	-	-	-	-	-	-	-	-	-	-	-	-	-
	Red(253)	1	1	1	1	1	1	0	1	0	0	0	0	0	0	0	0	0	0	0	0	0	0	0	0
	Red(254)	1	1	1	1	1	1	1	0	0	0	0	0	0	0	0	0	0	0	0	0	0	0	0	0
	Red(255) Bright	1	1	1	1	1	1	1	1	0	0	0	0	0	0	0	0	0	0	0	0	0	0	0	0
Green	Green(000) Dark	0	0	0	0	0	0	0	0	0	0	0	0	0	0	0	0	0	0	0	0	0	0	0	0
	Green(001)	0	0	0	0	0	0	0	0	0	0	0	0	0	0	1	0	0	0	0	0	0	0	0	0
	Green(002)	0	0	0	0	0	0	0	0	0	0	0	0	0	1	0	0	0	0	0	0	0	0	0	0
	-----	-	-	-	-	-	-	-	-	-	-	-	-	-	-	-	-	-	-	-	-	-	-	-	-
	-----	-	-	-	-	-	-	-	-	-	-	-	-	-	-	-	-	-	-	-	-	-	-	-	-
	Green(253)	0	0	0	0	0	0	0	1	1	1	1	1	1	1	0	1	0	0	0	0	0	0	0	0
	Green(254)	0	0	0	0	0	0	0	1	1	1	1	1	1	1	1	0	0	0	0	0	0	0	0	0
	Green(255) Bright	0	0	0	0	0	0	0	1	1	1	1	1	1	1	1	1	0	0	0	0	0	0	0	0
Blue	Blue(000) Dark	0	0	0	0	0	0	0	0	0	0	0	0	0	0	0	0	0	0	0	0	0	0	0	0
	Blue(001)	0	0	0	0	0	0	0	0	0	0	0	0	0	0	0	0	0	0	0	0	0	0	0	1
	Blue(002)	0	0	0	0	0	0	0	0	0	0	0	0	0	0	0	0	0	0	0	0	0	0	1	0
	-----	-	-	-	-	-	-	-	-	-	-	-	-	-	-	-	-	-	-	-	-	-	-	-	-
	-----	-	-	-	-	-	-	-	-	-	-	-	-	-	-	-	-	-	-	-	-	-	-	-	-
	Blue(253)	0	0	0	0	0	0	0	0	0	0	0	0	0	0	0	1	1	1	1	1	1	1	0	1
	Blue(254)	0	0	0	0	0	0	0	0	0	0	0	0	0	0	0	1	1	1	1	1	1	1	1	0
	Blue(255) Bright	0	0	0	0	0	0	0	0	0	0	0	0	0	0	0	1	1	1	1	1	1	1	1	1

Product Specification

3-7. Power Sequence

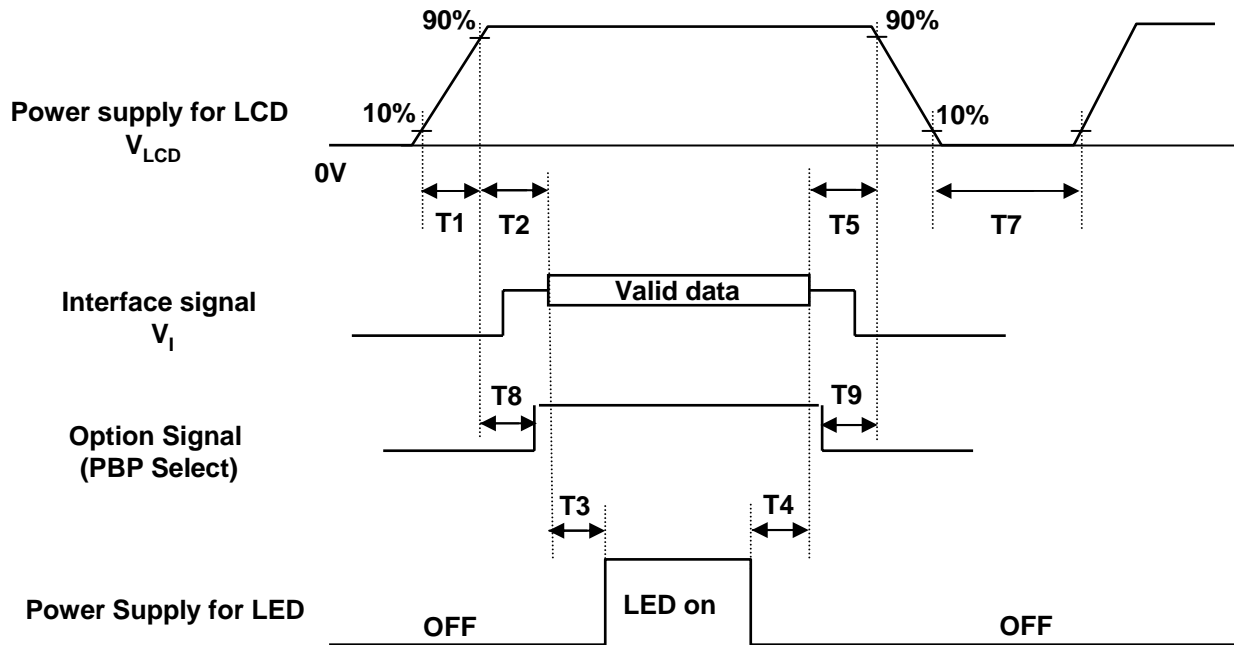

Table 9. Power Sequence

Parameter	Values			Units
	Min	Typ	Max	
T1	0.5	-	10	ms
T2	0.01	-	50	ms
T3	500	-	-	ms
T4	200	-	-	ms
T5	0.01	-	50	ms
T7	1000	-	-	ms
T8	0.5	-	T2	ms
T9	0	-	-	ms

Notes :

1. Please V_{LCD} power on only after connecting interface cable to LCD.
2. Please avoid floating state of interface signal at invalid period.
3. When the interface signal is invalid, be sure to pull down the power supply for LCD V_{LCD} to 0V.
4. LED power must be turn on after power supply for LCD an interface signal are valid.
5. It must be no valid signal at SCL & SDA line for 500ms, after VLCD input to LCD
6. If VLCD Power is Changed during on status, be sure to Pull down the LED Power on to 0V

Product Specification

4. Optical Specifications

Optical characteristics are determined after the unit has been 'ON' for approximately 30 minutes in a dark environment at 25±2°C. The values specified are at an approximate distance 50cm from the LCD surface at a viewing angle of Φ and θ equal to 0 ° and aperture 1 degree.

Figure. 6 presents additional information concerning the measurement equipment and method.

Figure 6. Optical Characteristic Measurement Equipment and Method

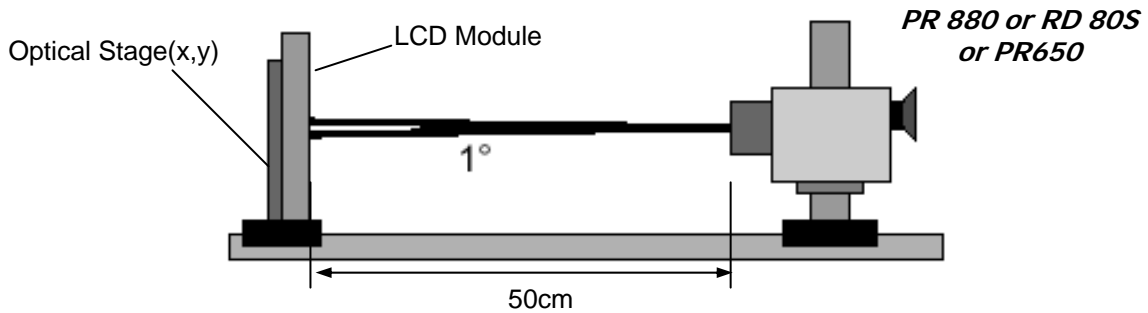

Table 10. Optical Characteristics (Ta=25 °C, V_{LCD}=12.0V, f_V=60Hz D_{CLK}=185.58MHz, Is=120mA)

Parameter	Symbol	Values			Units	Notes	
		Min	Typ	Max			
Contrast Ratio	CR	700	1000	-		1	
Surface Luminance, white	L _{WHITE}	250	300	-	cd/m ²	2	
Luminance Variation	δ _{WHITE}	75	-	-	%	3	
Response Time	GTG	T _{GTG_AVR}	14	28	ms	4	
Color Gamut		-	sRGB	-	%		
Color Coordinates [CIE1931] (By PR650)	RED	Rx	Typ -0.03	0.651	Typ +0.03		
		Ry		0.332			
	GREEN	Gx		0.307			
		Gy		0.631			
	BLUE	Bx		0.150			
		By		0.060			
	WHITE	Wx		0.313			
Wy		0.329					
Color Shift	Horizontal	θ _{CST_H}	-	178	-	Degree	5
	Vertical	θ _{CST_V}	-	178	-		
Viewing Angle (CR>10)							
General	Horizontal	θ _H	170	178	-	Degree	6
	Vertical	θ _V	170	178	-		
GSR @ 60dgree (Gamma shift rate)	Horizontal	δ _{Gamma_H}	-	-	20	%	7
	Vertical	δ _{Gamma_V}	-	-	20		
Gray Scale			-	2.2	-		8

Product Specification

Notes :

1. **Contrast ratio (CR)** is defined mathematically as :

It is measured at center point (1)

$$\text{Contrast ratio} = \frac{\text{Surface luminance with all white pixels}}{\text{Surface luminance with all black pixels}}$$

2. **Surface luminance** is the luminance value at center 1 point (1) across the LCD surface 50cm from the surface with all pixels displaying white.
For more information see Figure 7.

3. The **variation in surface luminance**, δ_{WHITE} is defined as :

$$\delta_{\text{WHITE}} = \frac{\text{Minimum (P1,P2, \dots, P9)}}{\text{Maximum (P1,P2, \dots, P9)}} \times 100 (\%)$$

For more information see Figure 7.

Figure 7. Luminance measuring point

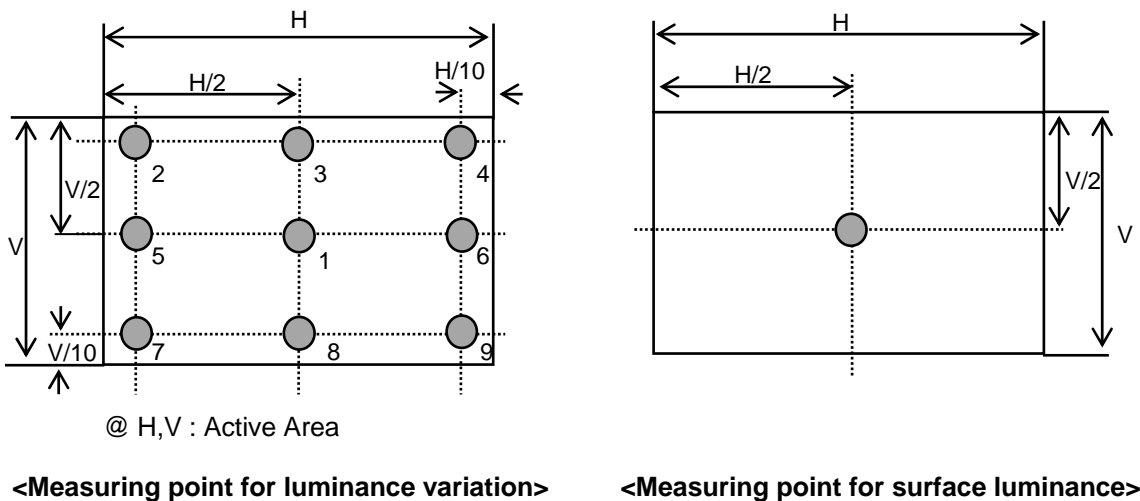

Product Specification

5. Color shift is the angle at which the average color difference for all Macbeth is lower than 0.02.

For more information see FIG.9 (**By EZ Contrast**)

- Color difference ($\Delta u'v'$)

$$u' = \frac{4x}{-2x+12y+3} \quad v' = \frac{9y}{-2x+12y+3} \quad \Delta u'v' = \sqrt{(u'_1 - u'_2)^2 + (v'_1 - v'_2)^2}$$

$$Avg(\Delta u'v') = \frac{\sum_{i=1}^{24} (\Delta u'v')_i}{24}$$

u'_1, v'_1 : $u'v'$ value at viewing angle direction
 u'_2, v'_2 : $u'v'$ value at front ($\theta=0$)

i : Macbeth chart number (Define 23 page)

- Pattern size : 25% Box size

- Viewing angle direction of color shift : Horizontal, Vertical

Color shift is defined as the following test pattern and color.

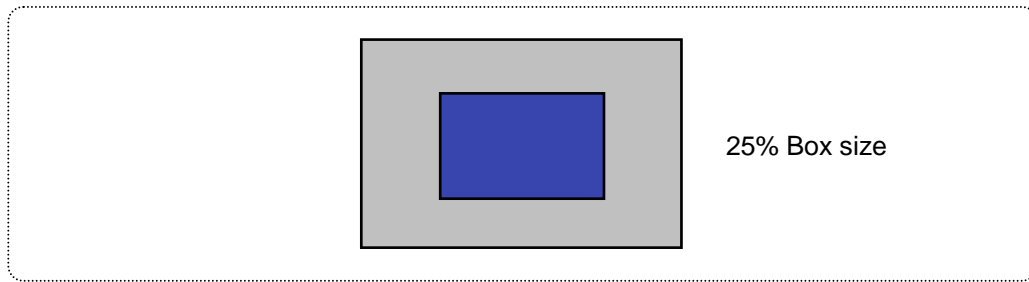

Figure 9. Color Shift Test Pattern

Average RGB values in Bruce RGB for Macbeth Chart

	Dark skin (i=1)	Light skin	Blue sky	Foliage	Blue flower	Bluish green
R	98	206	85	77	129	114
G	56	142	112	102	118	199
B	45	123	161	46	185	178
	Orange	Purplish blue	Moderate red	Purple	Yellow green	Orange yellow
R	219	56	211	76	160	230
G	104	69	67	39	193	162
B	24	174	87	86	58	29
	Blue	Green	Red	Yellow	Magenta	Cyan
R	26	72	197	241	207	35
G	32	148	27	212	62	126
B	145	65	37	36	151	172
	White	Neutral 8	Neutral 6.5	Neutral 5	Neutral 3.5	Black
R	240	206	155	110	63	22
G	240	206	155	110	63	22
B	240	206	155	110	63	22

Product Specification

6. **Viewing angle** is the angle at which the contrast ratio is greater than 10. The angles are determined for the horizontal or x axis and the vertical or y axis with respect to the z axis which is normal to the LCD surface. For more information see Figure 10 .

Figure 10. Viewing Angle

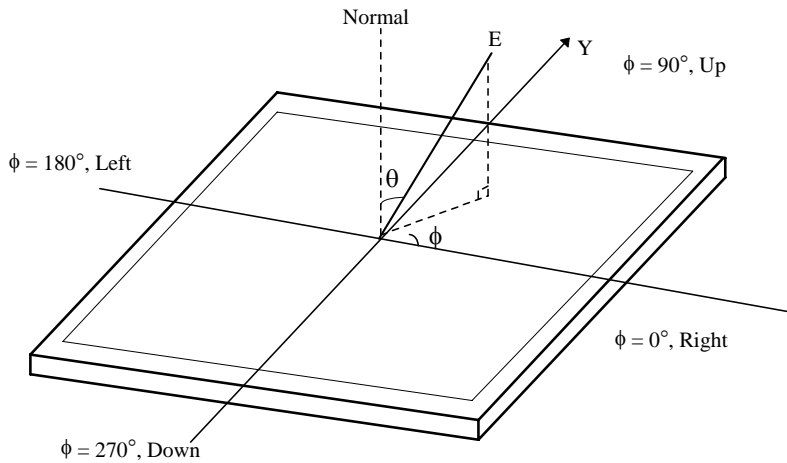

7. **GSR** is the rate of gamma shift at up, down, left and right 60 degree viewing angle compare with center gamma. For more information see FIG.10 and FIG.11 (**By EZ Contrast**)
- GSR (δ Gamma) is defined as :

$$GSR = \left(1 - \frac{\text{View angle Gamma Value (Up, Down, Reft, Light 60 Degree)}}{\text{Center Gamma Value (0 Degree)}} \right) \times 100$$

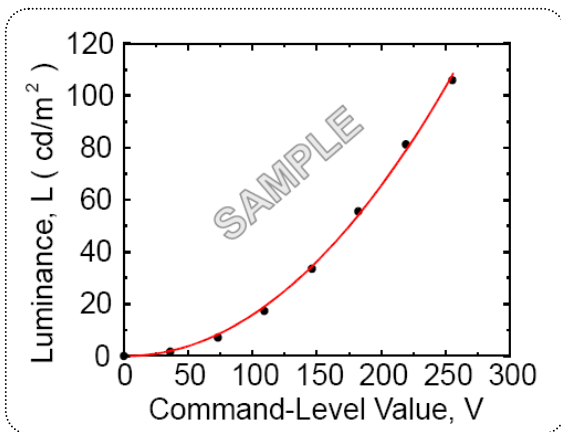

Figure11. Sample Luminance vs. gray scale (using a 256 bit gray scale)

$$L = aV^\gamma + L_b$$

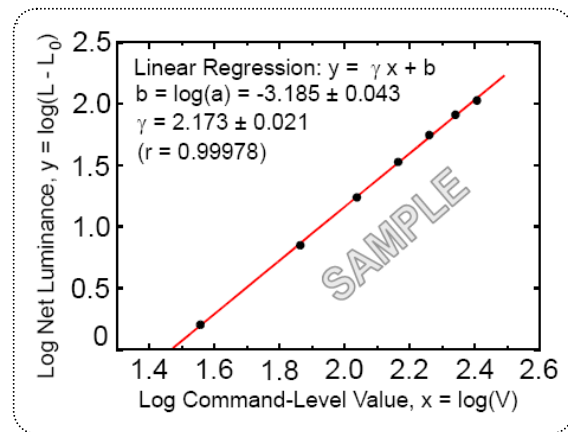

Figure 12. Sample Log-log plot of luminance vs. gray scale

$$\log(L - L_b) = r \log(V) + \log(a)$$

Here the Parameter α and γ relate the signal level V to the luminance L .
The GAMMA we calculate from the log-log representation (Figure 12.)

Product Specification

8. **Gray scale** specification
 Gamma Value is approximately 2.2.

Table 12. Gray Scale Specification

Gray Level	Relative Luminance [%] (Typ.)
0	0.10
15	0.35
31	0.80
47	1.80
63	3.80
79	6.30
95	10.0
111	15.0
127	20.5
143	27.3
159	34.6
175	42.5
191	51.3
207	61.2
223	72.3
239	85.3
255	100

Product Specification
4-2-1. 3D Optical Specification
Table 13. 3D Optical characteristics
 $T_a = 25^{\circ}\text{C}$, $V_{\text{LCD}} = 5.0\text{V}$, $f_v = 60\text{Hz}$, $f_{\text{CLK}} = 72.0\text{MHz}$, $I_s = 110\text{mA}$

Parameter	Symbol	Condition	Values			Units	Notes
			Min	Typ	Max		
3D Viewing Angle							
y axis, up ($\phi = 90^{\circ}$)	Φ_{yu+}	※ Cone angle (3D C/T $\leq 10\%$)	10	12	-	degree	5
y axis, down ($\phi = 270^{\circ}$)	Φ_{yd}						
3D Crosstalk (C/T)	-	Mid Axis (Center of Cone Angle)	-	1.3	3	%	4

4-2-2. 3D Optical Characteristic Reference
Table 14. 3D Optical Characteristic Ref.
 $T_a = 25^{\circ}\text{C}$, $V_{\text{LCD}} = 5.0\text{V}$, $f_v = 60\text{Hz}$, $f_{\text{CLK}} = 72.0\text{MHz}$, $I_s = 110\text{mA}$

Parameter	Symbol	Condition	Values			Units	Notes
			Min	Typ	Max		
3D Surface Luminance, white	L_{WH}	1Point (3D Glasses)	76	95	-	cd/m ²	3(Ref.)
3D Watching Distance		Mid Axis (Center of Cone Angle)	55	100		cm	6(Ref.)
3D Viewing Angle							
y axis, right ($\phi = 0^{\circ}$)	Φ_{yl}	(3D C/T $\leq 10\%$)	-	65	-	degree	5-1(Ref)
y axis, left ($\phi = 180^{\circ}$)	Φ_{yr}						

Notes :

In order to measure 3D viewing angle, it need to be prepared as below;

1. Measurement configuration

4-Test pattern images. Refer to FIG 13.

- . LW-RW : White for left and right eye
- . LW-RB : White for left eye and Black for right eye
- . LB-RW : Black for left eye and white for right eye
- . LB-RB : Black for left eye and right eye

Image files where black and white lines are displayed on even or odd lines.

Luminance measurement system (LMS) with narrow FOV (field of view) is used. Refer to FIG 6.

Product Specification

3. Measurement of 3D luminance (Reference)

- (i) Test image (LW-RW) is displayed.
- (ii) Left or right eyeglass are placed in front of LMS successively and luminance is measured at center 1 point where the notation for luminance measurement is “Lum(LE, LW-RW,1)” or “Lum(RE, LW-RW,1).

4. Measurement of 3D crosstalk

- (i) Test image (LB-RW, LW-RB and LB-RB) is displayed.
- (ii) Right or left eyeglass are placed in front of LMS successively and luminance is measured for position 1. with rotating LMS or sample vertically.

Average of

$$\text{and } \frac{\text{Lum(LE, LB-RW,1)} - \text{Lum(LE, LB-RB,1)}}{\text{Lum(LE, LW-RB,1)} - \text{Lum(LE, LB-RB,1)}} \\ \frac{\text{Lum(RE, LW-RB,1)} - \text{Lum(RE, LB-RB,1)}}{\text{Lum(RE, LB-RW,1)} - \text{Lum(RE, LB-RB,1)}}$$

- (iii) The 3D crosstalk (min.) is minimum 3D crosstalk within viewing angle.

5. Measurement of 3D Viewing Angle

3D viewing angle is the angle at which the 3D crosstalk is under 10%. The angles are determined for the vertical or y axis with respect to the z axis which is normal to the LCD module surface and measured for position 1. The typical center of U/D viewing angle is 0° (Φyu(up)) direction. For more information , see the Fig 15.

5-1. Measurement of 3D Viewing Angle (Left & Right) (Reference)

The angles are determined for the horizontal or x axis with respect to the z axis which is normal to the LCD module surface and measured for position 1.

Product Specification

Figure 16. Measurement of 3D Crosstalk and 3D viewing angle

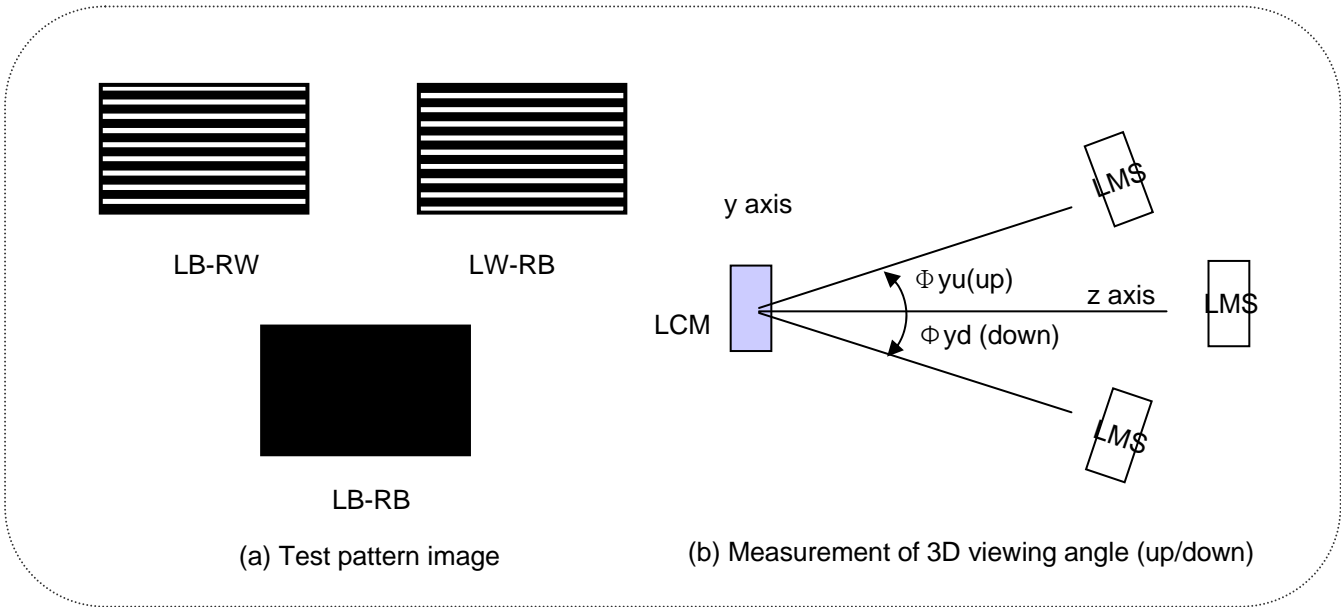

6. 3D Watching Distance (Reference)

FPR 3D Watching distance is 3D operating distance which has the range of under 10% Cross talk of front panel from center (Mid Axis).

Figure 17. 3D Watching Distance

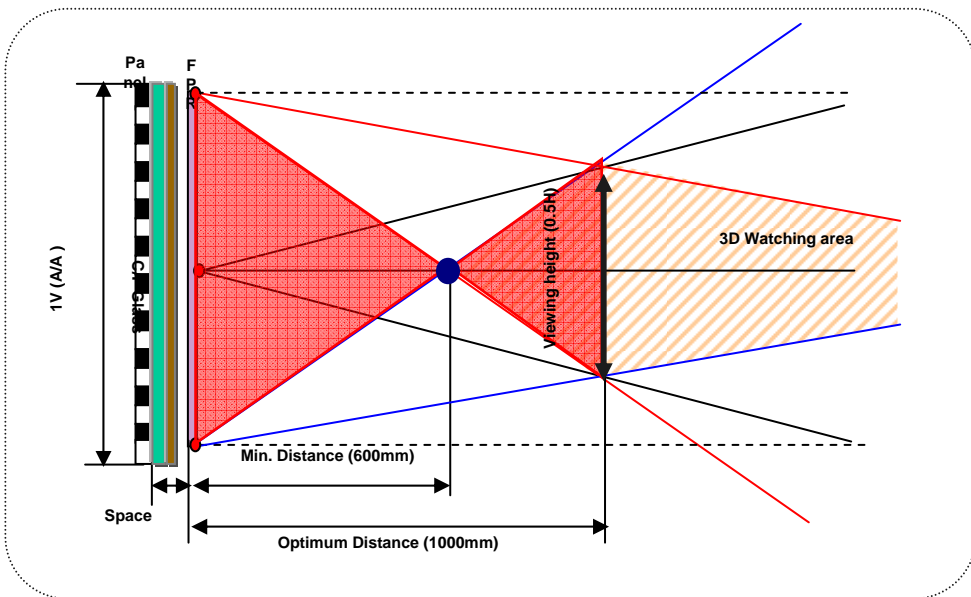

Product Specification
5. Mechanical Characteristics

The contents provide general mechanical characteristics. In addition the figures in the next page are detailed mechanical drawing of the LCD.

Table 15. Mechanical characteristics

Outline Dimension	Horizontal	693.6 mm
	Vertical	308.9 mm
	Depth	17.0 mm (Top : 11.1mm)
Bezel Area	Horizontal	-
	Vertical	-
Active Display Area	Horizontal	672.768 mm
	Vertical	283.824 mm
Weight	Typ. : 3,450 g , Max : 3,620 g	
Surface Treatment	Low Haze CLR treatment of the front polarizer	

Notes : Please refer to a mechanic drawing in terms of tolerance at the next page.

Product Specification

<REAR VIEW>

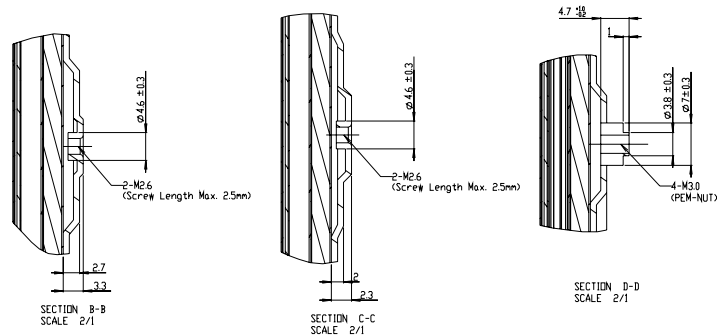
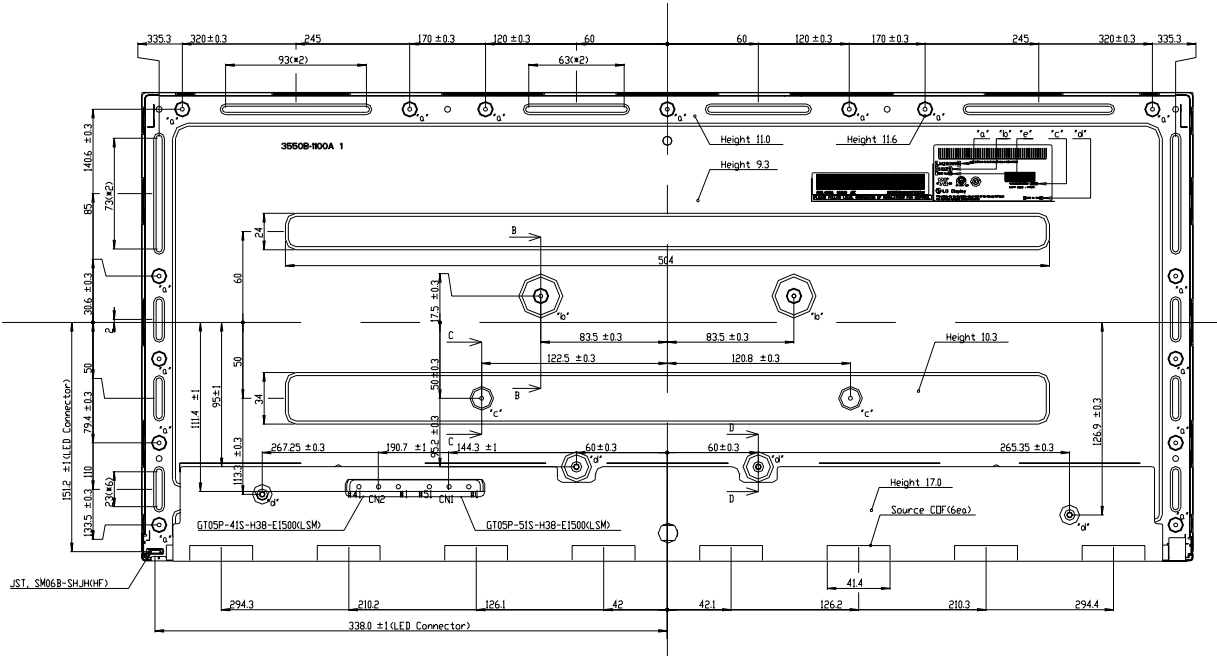

NOTES

1. I/F connector specification
(1) CNI : GT05P-51S-H38-E1500(LSM)
(2) CNI2 : GT05P-41S-H38-E1500(LSM)
2. LED connector specification : JST, SM06B-SHJ(KHF)
3. Torque of user hole: 3.0-4.0kgf-cm
4. Tilt and partial disposition tolerance of display area as following
(+): Panel is bigger than BL, (-): Panel is smaller than BL.
(1) X-direction : $-1.0 \leq A \leq +0.4$, $-1.0 \leq B \leq +0.4$
(2) Y-direction : $-1.0 \leq C \leq +0.4$, $-1.0 \leq D \leq +0.4$

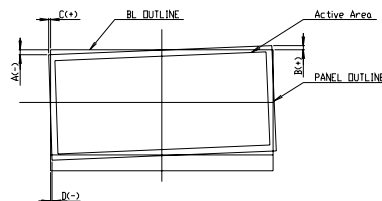

5. The LCM (#arp(#page)) is less than 12mm on the surface plate.
6. Unspecified tolerances to be ± 0.5
7. The CDF area is weak & sensitive, so please don't press the CDF area
8. Panel Assembly press spec : Max 5kgf/cm²
9. LCM Weight spec : Typ3450g, Max3620g

Product Specification
6. Reliability
Table 16. Environment test conditions

No	Test Item	Condition
1	High temperature storage test	Ta= 60°C 240h
2	Low temperature storage test	Ta= -20°C 240h
3	High temperature operation test	Ta= 50°C 50%RH 240h
4	Low temperature operation test	Ta= 0°C 240h
5	Humidity condition Operation	Ta= 40 °C ,90%RH
7	Altitude operating storage / shipment	0 - 16,400 feet(5,000m) 0 - 40,000 feet(12,192m)
8	Maximum Storage Humidity for 4 corner light leakage Mura.	Max 70%RH , Ta=40°C

[Result evaluation criteria]

There should be no change which might affect the practical display function when the display quality test is conducted under normal operating condition.

Product Specification**7. International Standards****7-1. Safety**

- a) UL 60950-1, Underwriters Laboratories Inc.
Information Technology Equipment - Safety - Part 1 : General Requirements.
- b) CAN/CSA C22.2 No.60950-1-07, Canadian Standards Association.
Information Technology Equipment - Safety - Part 1 : General Requirements.
- c) EN 60950-1, European Committee for Electrotechnical Standardization (CENELEC).
Information Technology Equipment - Safety - Part 1 : General Requirements.
- d) IEC 60950-1, The International Electrotechnical Commission (IEC).
Information Technology Equipment - Safety - Part 1 : General Requirements.
(Including report of IEC60825-1:2001 clause 8 and clause 9)

Notes

- 1. Laser (LED Backlight) Information

Class 1M LED Product IEC60825-1 : 2001 Embedded LED Power (Class1M)

- 2. Caution

: LED inside.
Class 1M laser (LEDs) radiation when open.
Do not open while operating.

7-2. EMC

- a) ANSI C63.4 "American National Standard for Methods of Measurement of Radio-Noise Emissions from Low-Voltage Electrical and Electronic Equipment in the Range of 9 kHz to 40 GHz." American National Standards Institute (ANSI), 2003.
- b) CISPR 22 "Information technology equipment – Radio disturbance characteristics – Limit and methods of measurement." International Special Committee on Radio Interference (CISPR), 2005.
- c) CISPR 13 "Sound and television broadcast receivers and associated equipment – Radio disturbance characteristics – Limits and method of measurement." International Special Committee on Radio Interference (CISPR), 2006.

7-3. Environment

- a) RoHS, Directive **2011/65/EU** of the European Parliament and of the council of **8 June 2011**

Product Specification

8. Packing

8-1. Designation of Lot Mark

a) Lot Mark

A	B	C	D	E	F	G	H	I	J	K	L	M
---	---	---	---	---	---	---	---	---	---	---	---	---

A,B,C : SIZE(INCH)
 E : MONTH

D : YEAR
 F ~ M : SERIAL NO.

Note

1. YEAR

Year	2011	2012	2013	2014	2015	2016	2017	2018	2019	2020
Mark	A	B	C	D	E	F	G	H	J	K

2. MONTH

Month	Jan	Feb	Mar	Apr	May	Jun	Jul	Aug	Sep	Oct	Nov	Dec
Mark	1	2	3	4	5	6	7	8	9	A	B	C

b) Location of Lot Mark

Serial No. is printed on the label. The label is attached to the backside of the LCD module.
 This is subject to change without prior notice.

8-2. Packing Form

a) Package quantity in one box : 9 pcs

b) Box Size : 840mm×365mm×420mm

Product Specification**9. PRECAUTIONS**

Please pay attention to the followings when you use this TFT LCD module.

9-1. MOUNTING PRECAUTIONS

- (1) You must mount a module using holes arranged in four corners or four sides.
- (2) You should consider the mounting structure so that uneven force (ex. Twisted stress) is not applied to the module. And the case on which a module is mounted should have sufficient strength so that external force is not transmitted directly to the module.
- (3) Please attach the surface transparent protective plate to the surface in order to protect the polarizer. Transparent protective plate should have sufficient strength in order to resist external force.
- (4) You should adopt radiation structure to satisfy the temperature specification.
- (5) Acetic acid type and chlorine type materials for the cover case are not desirable because the former generates corrosive gas of attacking the polarizer at high temperature and the latter causes circuit break by electro-chemical reaction.
- (6) Do not touch, push or rub the exposed polarizers with glass, tweezers or anything harder than HB pencil lead. And please do not rub with dust clothes with chemical treatment. Do not touch the surface of polarizer for bare hand or greasy cloth.(Some cosmetics are detrimental to the polarizer.)
- (7) When the surface becomes dusty, please wipe gently with absorbent cotton or other soft materials like chamois soaks with petroleum benzene. Normal-hexane is recommended for cleaning the adhesives used to attach front / rear polarizers. Do not use acetone, toluene and alcohol because they cause chemical damage to the polarizer.
- (8) Wipe off saliva or water drops as soon as possible. Their long time contact with polarizer causes deformations and color fading.
- (9) Do not open the case because inside circuits do not have sufficient strength.

9-2. OPERATING PRECAUTIONS

- (1) The spike noise causes the mis-operation of circuits. It should be lower than following voltage :
 $V = \pm 200\text{mV}$ (Over and under shoot voltage)
- (2) Response time depends on the temperature.(In lower temperature, it becomes longer.)
- (3) Brightness depends on the temperature. (In higher temperature, it becomes lower.)
And in lower temperature, response time(required time that brightness is stable after turned on) becomes longer.
- (4) Be careful for condensation at sudden temperature change. Condensation makes damage to polarizer or electrical contacted parts. And after fading condensation, smear or spot will occur.
- (5) When fixed patterns are displayed for a long time, remnant image is likely to occur.
- (6) Module has high frequency circuits. Sufficient suppression to the electromagnetic interference shall be done by system manufacturers. Grounding and shielding methods may be important to minimized the interference.
- (7) Please do not give any mechanical and/or acoustical impact to LCM. Otherwise, LCM can't be operated its full characteristics perfectly.
- (8) A screw which is fastened up the steels should be a machine screw.
(if not, it causes metallic foreign material and deal LCM a fatal blow)
- (9) Please do not set LCD on its edge.
- (10) When LCMs are used for public display defects such as Yogore, image sticking can not be guarantee.

Product Specification**9-3. ELECTROSTATIC DISCHARGE CONTROL**

Since a module is composed of electronic circuits, it is not strong to electrostatic discharge. Make certain that treatment persons are connected to ground through wrist band etc. And don't touch interface pin directly.

9-4. PRECAUTIONS FOR STRONG LIGHT EXPOSURE

Strong light exposure causes degradation of polarizer and color filter.

9-5. STORAGE

When storing modules as spares for a long time, the following precautions are necessary.

- (1) Store them in a dark place. Do not expose the module to sunlight or fluorescent light. Keep the temperature between 5°C and 35°C at normal humidity.
- (2) The polarizer surface should not come in contact with any other object.
It is recommended that they be stored in the container in which they were shipped.

9-6. HANDLING PRECAUTIONS FOR PROTECTION FILM

- (1) The protection film is attached to the bezel with a small masking tape.
When the protection film is peeled off, static electricity is generated between the film and polarizer.
This should be peeled off slowly and carefully by people who are electrically grounded and with well ion-blown equipment or in such a condition, etc.
- (2) When the module with protection film attached is stored for a long time, sometimes there remains a very small amount of glue still on the bezel after the protection film is peeled off.
- (3) You can remove the glue easily. When the glue remains on the bezel surface or its vestige is recognized, please wipe them off with absorbent cotton waste or other soft material like chamois soaked with normal-hexane.