

LM3123

LCD Module User Manual

Shenzhen TOPWAY Technology Co., Ltd.

Rev.	Descriptions	Release Date
0.1	Preliminary Release	2005-02-25
0.2	Typing Correction: 4.6 Display Command	2006-02-07
0.3	Typing Correction: 4.2 Resetting the LCD Module	2006-08-16

Table of Content

1. Basic Specifications	3
1.1 Display Specifications	3
1.2 Mechanical Specifications	3
1.3 Block Diagram	3
1.4 Terminal Functions	4
2. Absolute Maximum Ratings	5
3. Electrical Characteristics	5
3.1 DC Characteristics	5
3.2 AC Characteristics	5
4. Function Specifications	6
4.1 Basic Setting	6
4.2 Resetting the LCD Module	6
4.3 Adjusting the LCD Display Contrast	6
4.4 Display Data RAM Memory Map	7
4.5 Icons Memory Map	7
4.6 Display Command	8
5. Design and Handling Precaution	9

1. Basic Specifications

1.1 Display Specifications

- 1) LCD Display Mode : STN, Positive, Transflective
- 2) Display Color : Display Data = "1" : Deep Blue (*1)
: Display Data = "0" : Light Yellow Green(*2)
- 3) Viewing Angle : 6 H
- 4) Driving Method : 1/32 duty, 1/5bias
- 5) Backlight : Nil

Note:

*1. Color tone may slightly change by Temperature and Driving Condition.

*2. The Color is defined as the inactive / background color

1.2 Mechanical Specifications

- 1) Outline Dimension : 99.6 x 31.5 x 10.7MAX
(see attached Outline Drawing for details)

1.3 Block Diagram

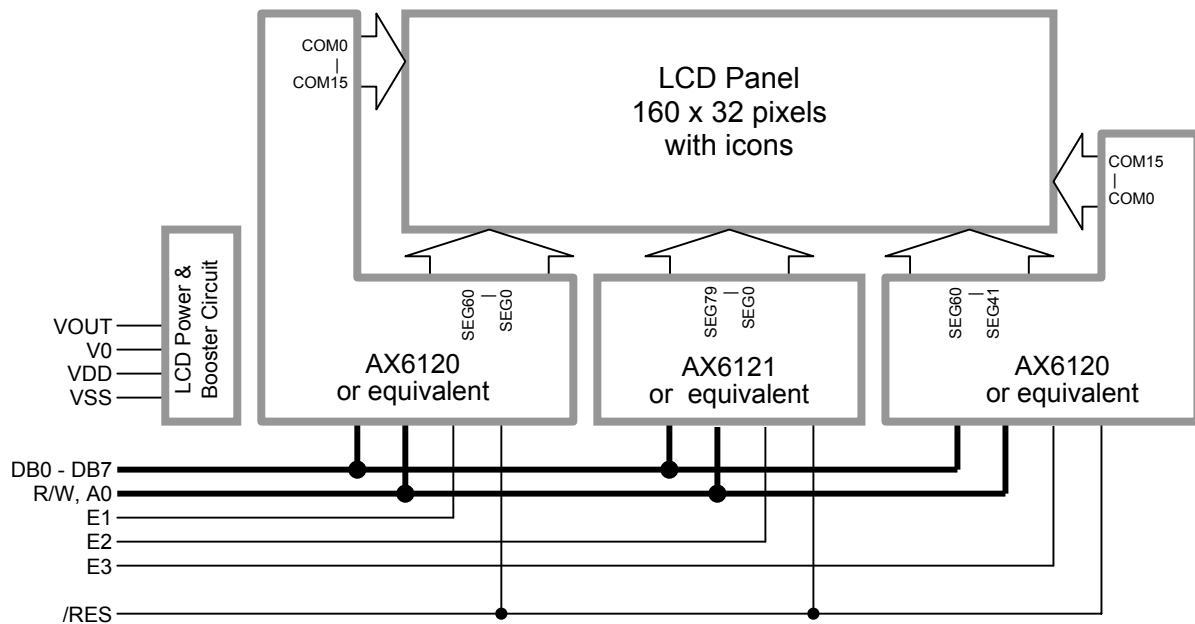

1.4 Terminal Functions

Pin No.	Pin Name	I/O	Descriptions
1	VSS	Power	Negative Power Supply, Ground (0V)
2	VDD	Power	Positive Power Supply
3	V0	Input	LCD Contrast Reference
4	VOUT	Power	LCD Booster Output for V0
5	/RES	Input	Reset Signal Resetting: rising edge and falling edge of /RES Normal Running: /RES=High
6	DB7	I/O	Bi-directional Data Bus for display data or instruction data
	:		
13	DB0		
14	R/W	Input	Read / Write Control Signal
15	A0	Input	A0 = H; DB0 – DB7 = Display Data A0 = L; DB0 – DB7 = Instruction Data
16	E1	Input	Enable Signal for left section of the LCD module
17	E2	Input	Enable Signal for middle section of the LCD module
18	E3	Input	Enable Signal for right section of the LCD module
19	NC	-	No Connection
20	NC	-	No Connection

Note:

- *1. Display or instruction data could write into the LCD module's driver/controllers individually or at the same time.
- *2. Only read display or instruction data form one of the driver/controller in the LCD module at a time, otherwise unexpected data collision will occur.

2. Absolute Maximum Ratings

Items	Symbol	Min.	Max.	Unit	Condition
Supply Voltage	V_{DD}	0	7.0	V	$V_{SS} = 0V$
Operating Temperature	T_{OP}	-0	50	°C	No Condensation
Storage Temperature	T_{ST}	-10	60	°C	No Condensation

Cautions:

Any Stresses exceeding the Absolute Maximum Ratings may cause substantial damage to the device. Functional operation of this device at other conditions beyond those listed in the specification is not implied and prolonged exposure to extreme conditions may affect device reliability.

3. Electrical Characteristics

3.1 DC Characteristics

$V_{SS}=0V, V_{DD} =5V, T_{OP} =25^{\circ}C$

Items	Symbol	MIN.	TYP.	MAX.	Unit	Applicable Pin
Operating Voltage	V_{DD}	4.8	5.0	5.2	V	VDD
Input High Voltage	V_{IH}	4.0	-	V_{DD}	V	A0, R/W, E1, E2, E3,
Input Low Voltage	V_{IL}	V_{SS}	-	0.6	V	DB0-DB7, /RES
Operating Current	I_{DD}	-	1.2	4.5	mA	VDD (*1)

Note:

*1. Normal text display

3.2 AC Characteristics

$V_{SS}=0V, V_{DD} =5V, T_{OP} =25^{\circ}C$

Item	Symbol	MIN.	TYP.	MAX.	Unit
System cycle time	t_{cyc6}	1250	-	-	ns
Address setup time	t_{aw6}	25	-	-	ns
Address hold time	t_{ah6}	13	-	-	ns
Data setup time	t_{ds6}	100	-	-	ns
Data hold time	t_{dh6}	13	-	-	ns
Output disable time	t_{oh6}	-	-	75	ns
Access time	t_{acc6}	-	-	115	ns
Enable pulse width (Read)	t_{ewhr}	125	-	-	ns
Enable pulse width (Write)	t_{ewhw}	100	-	-	ns
Rise time	t_r	-	-	12	ns
Fall time	t_f	-	-	12	ns

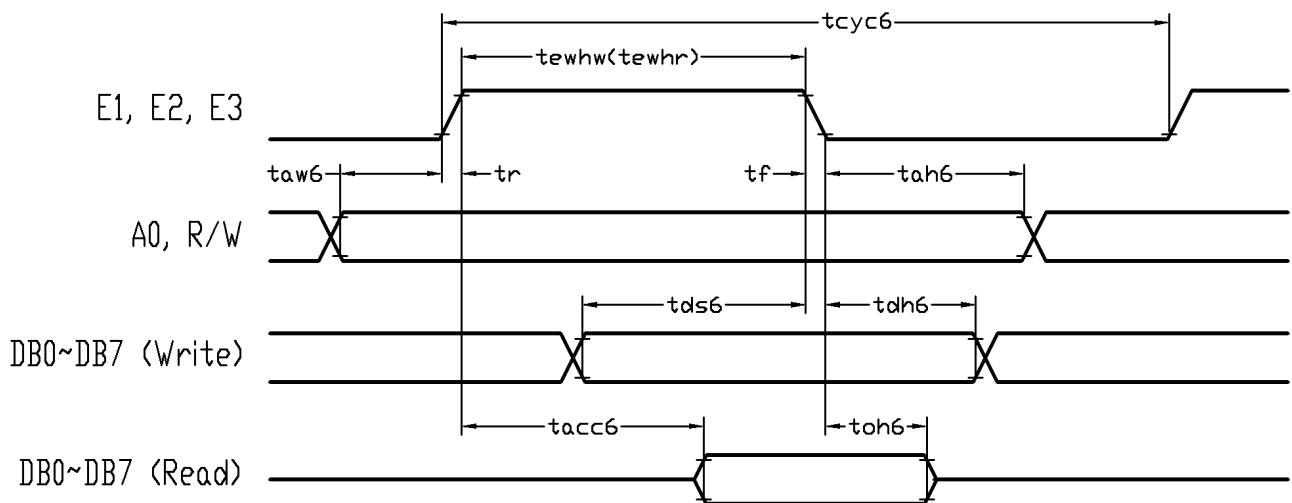

Host Read/Write Timing Diagram

4. Function Specifications

4.1 Basic Setting

To drive the LCD module correctly and provide normally display, please use the following setting

Select duty = 1/32
Static drive ON/OFF = OFF (Normal Driving)
ADC = 1
Display Start Line = 0
DISPLAY ON/OFF = ON
Read-Modify-Write = OFF

4.2 Resetting the LCD Module

The LCD module should be initialized by the hardware reset during power on sequence.

Keep /RES terminal at high level, during the power on.

After the power supply is stable, a hardware reset signal should apply to the /RES terminal.

The LCD module will be initialized at the rising and falling edge of the /RES signal.

For normal running, /RES signal must keep at high level.

After the Hardware Reset, the LCD module controllers' status will be:

(note: this is not the basic setting for normal display)

- Display ON/OFF = OFF
- Display start line register = 0
- Static drive ON/OFF = OFF (Normal Driving)
- Column address counter = 0
- Page address register = Page 3
- Select duty = 1/32
- ADC = 1
- Read-Modify-Write = OFF

4.3 Adjusting the LCD Display Contrast

A Variable-Resistor must be connected to the LCD module for providing a reference to V0. Adjusting the VR will result the change of LCD display contrast.

The recommended value of VR is 25k to 50k

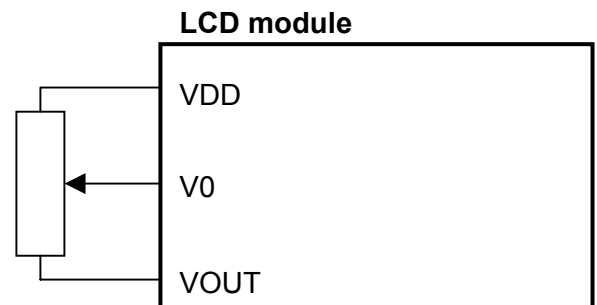





4.4 Display Data RAM Memory Map

Page Address	data	LCD Display (front view)		
0	D0 : D7	160x32 pixels		
1	D0 : D7			
2	D0 : D7			
3	D0 : D7			
Column Address		14h → 4Fh	00h → 4Fh	13h → 26h
Driver (accessed by)		E1	E2	E3

Note:

- *1. Display Start Line = 0
- *2. ADC = 1

4.5 Icons Memory Map

Icons	Driver (accessed by)	Page Address	Column Address	data
	E1	01h	13h	D7
				D6
				D5
				D4

4.6 Display Command

Instructions	Code										Function	Note	
	R/W	A0	DB7	DB6	DB5	DB4	DB3	DB2	DB1	DB0			
Display ON/OFF	0	0	1	0	1	0	1	1	1	0/1	0 = OFF 1 = ON (Display Data RAM is not affected)	*1	
Set Display Start Line	0	0	1	1	0	Display Start Line (0 ~31)					Specifies RAM line corresponding to the top line of display	*1	
Set Page Address	0	0	1	0	1	1	1	0	Page (0 ~ 3)		Set Page Address Register	*1	
Set Column Address	0	0	0	Column Address (0 ~ 79)								Set Column Address Counter	*1
Read Status	1	0	Busy	ADC	ON/OFF	Reset	0	0	0	0	Busy=1, Busy Busy=0, Ready ADC=1, CW output ADC=0, CCW output ON/OFF=1, Display off ON/OFF=0, Display on Reset=1, Being reset Reset=0, Normal	*3	
Write Display Data	0	1	Display Data								Write Display Data to display data RAM		*1
Read Display Data	1	1	Display Data								Read Display Data from display data RAM		*3
Select ADC	0	0	1	0	1	0	0	0	0	0/1	0 = CW output 1 = CCW output	*1	
Static Drive ON/OFF	0	0	1	0	1	0	0	1	0	0/1	0 = normal drive 1 = static drive	*1	
Select duty	0	0	1	0	1	0	1	0	0	0/1	0 = 1/16 duty 1 = 1/32 duty	*1	
Read-Modify-Write	0	0	1	1	1	0	0	0	0	0	Read-modify-write = ON	*1	
End	0	0	1	1	1	0	1	1	1	0	Read-modify-write = OFF	*1	
Reset	0	0	1	1	1	0	0	0	1	0	Software Reset	*1	

Note:

*1. For the details of the Display Command, please refer to AX6120 datasheet.

*2. Instruction could be write into both drivers at the same time.

*3. Only read display data or status form one of the driver/controller in the LCD module at a time, otherwise unexpected data collision will occur.

5. Design and Handling Precaution

1. The LCD panel is made by glass. Any mechanical shock (eg. dropping from high place) will damage the LCD module.
2. Do not add excessive force on the surface of the display, which may cause the Display color change abnormally.
3. The polarizer on the LCD is easily get scratched. If possible, do not remove the LCD protective film until the last step of installation.
4. Never attempt to disassemble or rework the LCD module.
5. Only Clean the LCD with Isopropyl Alcohol or Ethyl Alcohol. Other solvents (eg. water) may damage the LCD.
6. When mounting the LCD module, make sure that it is free from twisting, warping and distortion.
7. Ensure to provide enough space (with cushion) between case and LCD panel to prevent external force adding on it, or it may cause damage to the LCD or degrade the display result.
8. Only hold the LCD module by its side. Never hold LCD module by add force on the heat seal or TAB.
9. Never add force to component of the LCD module. It may cause invisible damage or degrade of the reliability.
10. LCD module could be easily damaged by static electricity. Be careful to maintain an optimum anti-static work environment to protect the LCD module.
11. When peeling off the protective film from LCD, static charge may cause abnormal display pattern. It is normal and will resume to normal in a short while.
12. Take care and prevent get hurt by the LCD panel sharp edge.
13. Never operate the LCD module exceed the absolute maximum ratings.
14. Keep the signal line as short as possible to prevent noisy signal applying to LCD module.
15. Never apply signal to the LCD module without power supply.
16. IC chip (eg. TAB or COG) is sensitive to the light. Strong lighting environment could possibly cause malfunction. Light sealing structure casing is recommend.
17. LCD module reliability may be reduced by temperature shock.
18. When storing the LCD module, avoid exposure to the direct sunlight, high humidity, high temperature or low temperature. They may damage or degrade the LCD module.