

TO : _____

规格书编号

File No.

PN-RD-0028A

作成日 Issue Date:

2012年(Y)09月(M)15日(D)

改订日 Revision Date:

《新规
New《变更》
Revision

产品规格书

Product Specification

产品名
Product TFT-LCD Module

机种名
Model LM315TU3A

【接收印栏】

--

※ 本基准书由封面、附件等全 21 页构成。

如果对该规格书有异议, 请在下订单前提出。

※ This Product Specification have 21 pages including the coversheet and Appendices. Please negotiate the objection point before purchase order.

中电熊猫集团
南京中电熊猫液晶显示科技有限公司
研发中心 设计整合部

CEC PANDA GROUP

NANJING CEC PANDA LCD TECHNOLOGY CO., LTD.

R&D CENTER, DESIGN INTEGRATION SECTION.

部长	科长	主管	担当
林 东 11/2/12	李 建 邦 2012.9.15		杨 东 2012.9.15

-CONTENTS -

REVISION HISTORY	3
1. GENERAL DESCRIPTION	4
1.1 OVERVIEW	4
1.2 CHARACTERISTICS	4
1.3 MECHANICAL SPECIFICATIONS	4
2. ABSOLUTE MAXIMUM RATINGS	4
2.1 ABSOLUTE RATINGS OF ENVIRONMENT	4
3. ELECTRICAL CHARACTERISTICS	5
3.1 ABSOLUTE MAXIMUM RATING	5
3.2 CONTROL CIRCUIT DRIVING	5
3.3 LED LIGHTBAR SPECIFICATION FOR BACKLIGHT	7
4. INTERFACE PIN CONNECTION	8
4.1 TFT LCD MODULE	8
4.2 BLOCK DIAGRAM (TFT LCD MODULE)	9
4.3 LVDS INTERFACE	10
4.4 COLOR DATA INPUT ASSIGNMENT	10
4.5 BACKLIGHT INTERFACE CONNECTION	12
4.6 BACKLIGHT UNIT	12
5. INTERFACE TIMING	13
5.1 INPUT SIGNAL TIMING SPECIFICATIONS	13
5.2 LVDS SIGNAL CHARACTERISTICS	13
6. OPTICAL CHARACTERISTICS	15
6.1 OPTICAL SPECIFICATION	15
7. DEFINITION OF LABELS	17
7.1 MODULE LABEL	17
7.2 PACKING LABEL	17
8. PACKING	17
8.1 PACKING SPECIFICATIONS	17
8.2 PACKING METHOD	18
9. CARTON STORAGE CONDITION	18
10. PRECAUTIONS	18
10.1 ASSEMBLY AND HANDLING PRECAUTIONS	18
10.2 SAFETY PRECAUTIONS	19
11. RELIABILITY	19
12. MECHANICAL DRAWING	19



REVISION HISTORY

MODEL NO: LM315TU3A

DATE	NO.	REVISED No.	PAGE	SUMMARY	NOTE
2012/09/15	PN-RD-0028A	T 1.0	21	1 st issue	Tentative

1. GENERAL DESCRIPTION

1.1 OVERVIEW

This module is color active matrix LCD module incorporating amorphous silicon TFT(Thin Film Transistor) LCD panel. It is composed of a color TFT-LCD panel, driver ICs, LED Backlight... etc. Graphics and texts can be displayed on a 1366×RGB×768 dots panel with about 16,777,216 colors(R/G/B 8bit in each color) by using LVDS(Low Voltage Differential Signaling) to interface, +12V of DC supply voltage.

In order to improve the response time of LCD, this module applies the Over Shoot driving (O/S driving) technology for the control circuit. In the O/S driving technology, signals are being applied to the Liquid Crystal according to a pre-fixed process as an image signal of the present frame when a difference is found between image signal of the previous frame and that of the current frame after comparing them.

By using the captioned process, the image signals of this LCD module are being set so that image response can be completed within one frame, as a result, image blur can be improved and clear image performance can be realized.

1.2 CHARACTERISTICS

CHARACTERISTICS ITEMS	SPECIFICATIONS
Screen Diagonal [in]	31.5"
Pixels [lines]	1366×768
Active Area [mm]	697.685 (H) x 392.256 (V)
Pixel Pitch [mm]	0.51075(H) x 0.51075 (V)
Pixel Arrangement	RGB vertical stripe
Display Colors	16.7M
Display Mode	Normally Black
Surface treatment (Without the protection film)	Anti-glare,2H

1.3 MECHANICAL SPECIFICATIONS

Item		Min.	Typ.	Max.	Unit	Remark
Module Size	Horizontal (H)	724.2	725.2	726.2	mm	[Note 1]
	Vertical (V)	420.9	421.9	422.9	mm	[Note 1]
	Depth (D)	17.3	18.3	19.3	mm	[Note 1]
Weight			5500	6000	g	

[Note 1] Please refer to the attached drawings for more information of front and back outline dimensions and the dimension of bosses are not included.

2. ABSOLUTE MAXIMUM RATINGS

2.1 ABSOLUTE RATINGS OF ENVIRONMENT

Item	Symbol	Value		Unit	Remark
		Min.	Max.		
Storage Temperature	T _{ST}	-20	+60	°C	[Note 1,3]
Operating Ambient Temperature	T _{OP}	0	50	°C	[Note 1,2,3]

Storage Condition: With shipping package.

Shelf life: one year

[Note 1] Temperature and relative humidity range is shown in the figure below.

- 80 %RH Max. (Ta ≤ 40 °C).
- Wet-bulb temperature should be 39 °C Max. (Ta > 40 °C).
- No condensation.

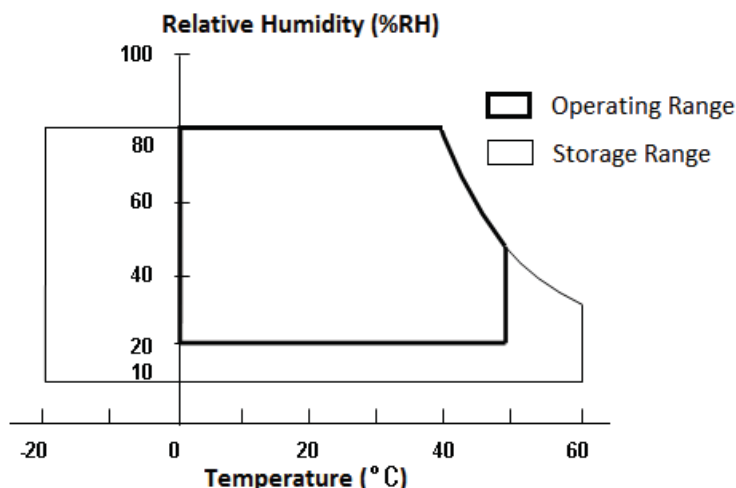

[Note 2] The maximum operating temperature is based on the test condition that the surface temperature of display area is less than or equal to 50 °C with LCD module alone in a temperature controlled chamber. Thermal management should be considered in your product design to prevent the surface temperature of display area from being over 60 °C. The range of operating temperature may degrade in case of improper thermal management in your product design.

[Note 3] The rating of environment is base on LCD module. Except LCD module, the customer has to consider the ability of other parts of LCD set and LCD set assembly process.

3. ELECTRICAL CHARACTERISTICS

3.1 ABSOLUTE MAXIMUM RATING

Parameter	Symbol	Condition	Ratings	Unit	Remark
+12V supply voltage	V _{CC}	T _a =25°C	0~+14	V	CN1 Pin1~4
Control voltage	V _{SELLVDS}	T _a =25°C	-0.3~3.6	V	CN1 Pin9
Storage temperature	T _{stg}	-	-20~+60	°C	
Operation temperature	T _{opa}	-	0~+50	°C	

3.2 CONTROL CIRCUIT DRIVING

Parameter		Symbol	Min.	Typ.	Max.	Unit	Remark
+12V supply voltage	Supply voltage	V _{CC}	+10.8	+12.0	+13.2	V	[Note 1]
	Current dissipation	I _{CC}	-	350	TBD	mA	[Note 2]
		I _{RUSH}	-	-	TBD	A	[Note 5]
Permissible input ripple voltage		V _{RP}	-	-	100	mV _{p-p}	V _{CC} =+12.0V
Differential input threshold voltage	High	V _{TH}	100	-	-	mV	[Note 4]
	Low	V _{TL}	-	-	-100	mV	
Input Low voltage		V _{IL}	0	-	0.7	V	[Note 3]
Input High voltage		V _{IH}	2.7	-	3.3	V	
Input leak current (Low)		I _{IL}	-	-	400	μA	V _I =0V [Note 3]
Input leak current (High)		I _{IH}	-	-	100	μA	V _I =3.3V [Note 3]
Terminal resistor		R _T	-	100	-	Ω	Differential input
Input Differential voltage		VID	200	400	600	mV	[Note 4]
Differential input common mode voltage		V _{CM}	VID /2	1.2	2.4- VID /2	V	[Note 4]

V_{CM}: Common mode voltage of LVDS driver.

[Note 1]

Input voltage sequences

$50\mu s \leq t1 \leq 20ms$

$20ms < t2-1$

$20ms < t2-2$

$0 < t3-1 \leq 1s$

$0 < t3-2 \leq 1s$

$1s \leq t4$

$500ms \leq t5-1$

$500ms \leq t5-2$

$0 < t6-1$

$0 < t6-2$

Dip conditions for supply voltage

a) $9.1V \leq V_{CC} < 10.8V$

$t_d \leq 10ms$

b) $V_{CC} < 9.1V$

Dip conditions for supply voltage is based on input voltage sequence.

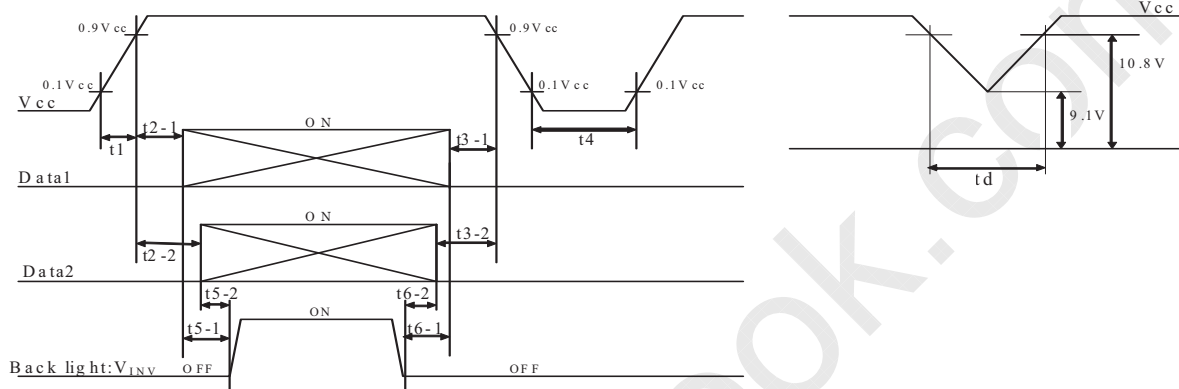

※ Data1: CLKIN±, RIN0±, RIN1±, RIN2±, RIN3±

※ Data2: SELVDS

※ About the relation between data input and back light lighting, please base on the above-mentioned input sequence.

※ When back light is switched on before panel operation or after a panel operation stop, it may not display normally. But this phenomenon is not based on change of an incoming signal, and does not give damage to a liquid crystal display.

[Note 2] Typical current situation: 256 gray-bar pattern (VCC = +12.0V).

The explanation of RGB gray scale is seen in section 8.

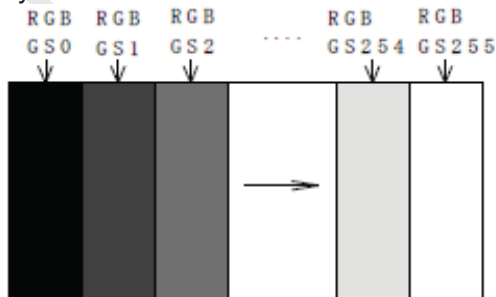

Typical current situation

[Note 3] SELVDS

[Note 4] CLKIN+/CLKIN-, RIN0+/RIN0-, RIN1+/RIN1-, RIN2+/RIN2-, RIN3+/RIN3-

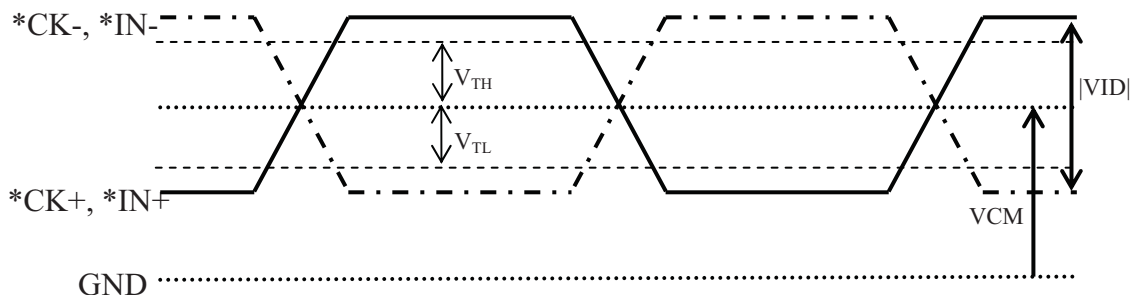

[Note 5] The Rush current corrugation at the time of power on.

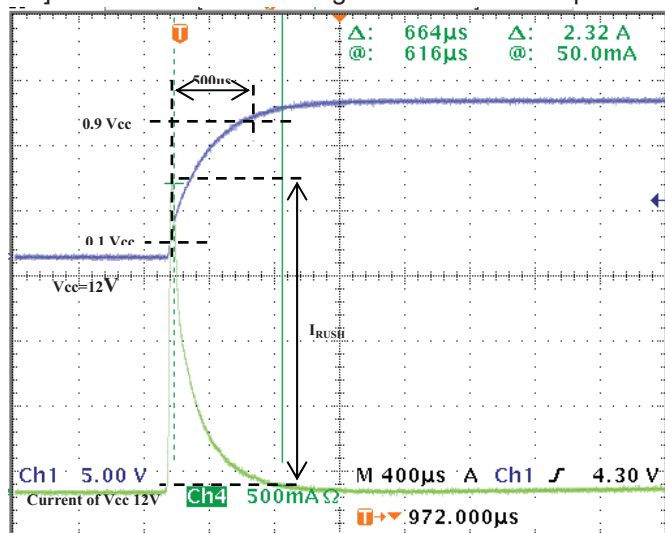

Ton: Vcc(+12V) Rising Time
From 10%Vcc to 90%Vcc
I: Current of Vcc(+12V)
I_{RUSH}: The max current
After Vcc rise.

[HOW TO]
Measure the Vcc(12V) when you turn
the power on. At the same time,
measure the current of Vcc(12V).
The single mode of the oscilloscope is
useful in this case.

3.3 LED LIGHTBAR SPECIFICATION FOR BACKLIGHT

Parameter	Symbol	Value			Unit	Note
		Min.	Typ.	Max.		
Input Voltage	V _{pin}	52.2	58.5	64.8	VDC	Duty 100% [Note 1]
Input Current Per input pin	I _{pin}	-	120	-	mADC	Duty 100% [Note 1]
LED Life Time	LT	30,000	-	-	Hrs	[Note 2]
Power Consumption	P _{BL}	25.1	28.1	31.1	W	Duty 100% [Note 3]
Dimming Duty Ratio	-	20	-	100	%	

[Note 1] Permanent damage to the device may occur if maximum values are exceeded. Function operation should be restricted to the conditions described under Normal Operating Conditions.

[Note 2] The life time of LED is defined as the time when it continues to operate under the condition at Ta = 25±2°C and I_{pin} = 120 mA (per string) until the brightness becomes ≅ 50% of its original value.

[Note 3] P_{BL} = V_{pin} × I_{pin} × (4) input pins.

4. INTERFACE PIN CONNECTION

4.1 TFT LCD MODULE

CN1 (Interface signals and +12V DC power supply) shown on the next table.

Using connector: 093G30-00001A-M4 (STARCONN) or equivalent device.

Matching connector: FI-X30C2L(Japan Aviation Electronics Ind., Ltd) or equivalent device.

Matching LVDS transmitter: THC63LVDM83R (THine) or equivalent device.

Pin No.	Symbol		Remark
1	VCC	+12V Power Supply	[Note 3]
2	VCC	+12V Power Supply	
3	VCC	+12V Power Supply	
4	VCC	+12V Power Supply	
5	GND	Ground	
6	GND	Ground	
7	GND	Ground	
8	WP	EEPROM Write Protection (for P-Vcom) (0V~0.7V_Disable,2.7V~3.3V/Open_Enable)	
9	SELLVDS	Select LVDS data format[Note 1]	Default: pull down (L:GND) [Note 2]
10	Reserved	Not Available	
11	GND	Ground	
12	RIN0-	Negative(-) LVDS differential data input	LVDS
13	RIN0+	Positive(+) LVDS differential data input	LVDS
14	GND	Ground	
15	RIN1-	Negative(-) LVDS differential data input	LVDS
16	RIN1+	Positive(+) LVDS differential data input	LVDS
17	GND	Ground	
18	RIN2-	Negative(-) LVDS differential data input	LVDS
19	RIN2+	Positive(+) LVDS differential data input	LVDS
20	GND	Ground	
21	CLKIN-	Clock Signal(-)	LVDS
22	CLKIN+	Clock Signal(+)	LVDS
23	GND	Ground	
24	RIN3-	Negative(-) LVDS differential data input	LVDS
25	RIN3+	Positive(+) LVDS differential data input	LVDS
26	GND	Ground	
27	Reserved	Not Available	
28	SCL	Serial clock input (for P-Vcom)	
29	SDA	Serial data input (for P-Vcom)	
30	GND	Ground	

[Note 1] SELLVDS

Transmitter		SELLVDS	
Pin No	Data	VESA	JEITA
		= L(GND) or Open	=H(3.3V)
51	TA0	R0(LSB)	R2
52	TA1	R1	R3
54	TA2	R2	R4
55	TA3	R3	R5
56	TA4	R4	R6
3	TA5	R5	R7(MSB)
4	TA6	G0(LSB)	G2
6	TB0	G1	G3
7	TB1	G2	G4
11	TB2	G3	G5
12	TB3	G4	G6
14	TB4	G5	G7(MSB)
15	TB5	B0(LSB)	B2

19	TB6	B1	B3
20	TC0	B2	B4
22	TC1	B3	B5
23	TC2	B4	B6
24	TC3	B5	B7(MSB)
27	TC4	NA	NA
28	TC5	NA	NA
30	TC6	DE(*)	DE(*)
50	TD0	R6	R0(LSB)
2	TD1	R7(MSB)	R1
8	TD2	G6	G0(LSB)
10	TD3	G7(MSB)	G1
16	TD4	B6	B0(LSB)
18	TD5	B7(MSB)	B1
25	TD6	NA	NA

NA: Not Available

(*)The display position is prescribed by the rise of DE (Display Enable) signal, please do not fix DE signal during operation at "High."

[Note 2] The equivalent circuit figure of the terminal

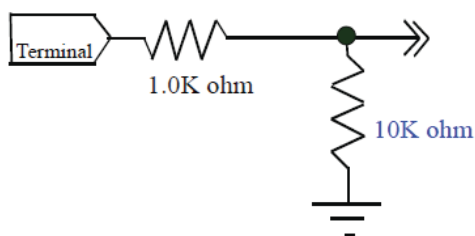

[Note 3] The location of Pin 1 is shown in Fig.12-2.

4.2 BLOCK DIAGRAM (TFT LCD MODULE)

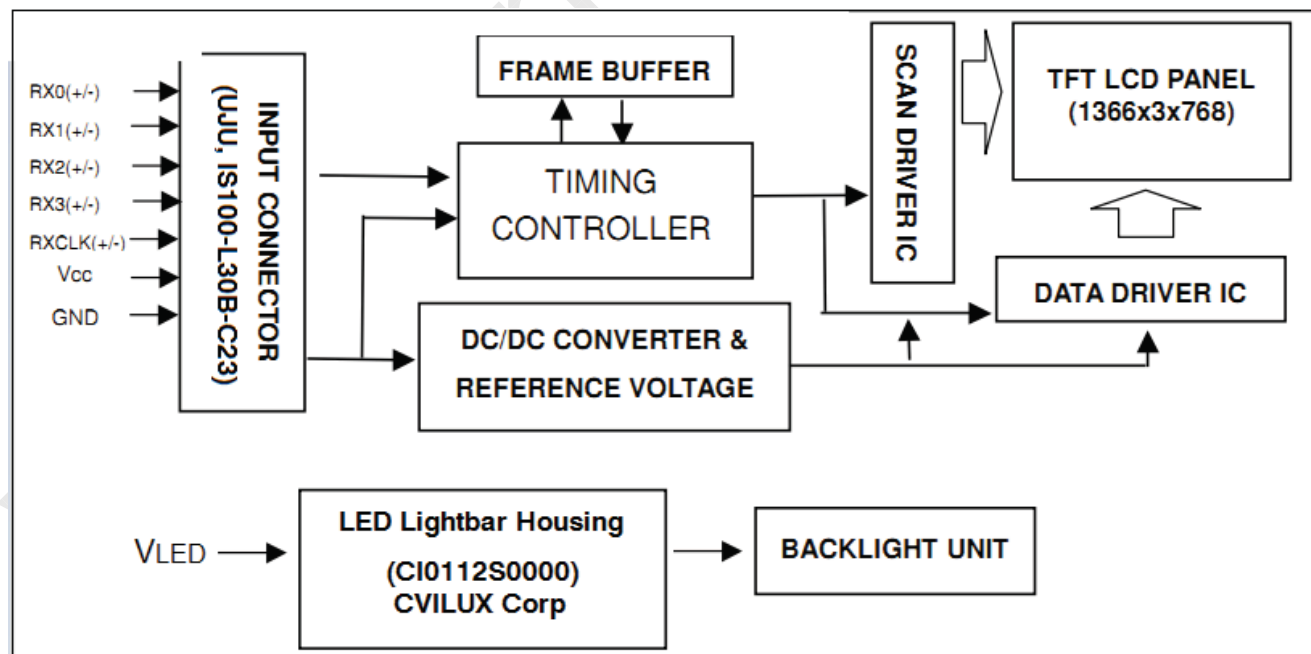

4.3 LVDS INTERFACE

VESA Format: SELLVDS = L(GND) or OPEN(FLOATING)

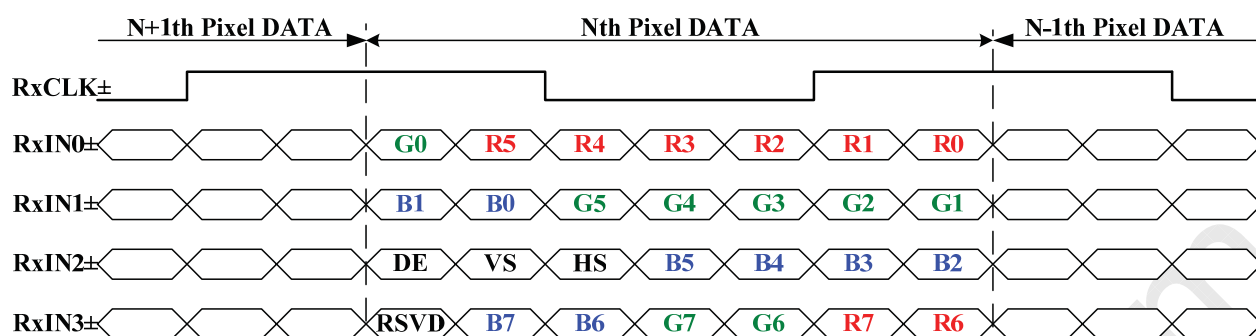

JEIDA Format: SELLVDS = HIGH(3.3V)

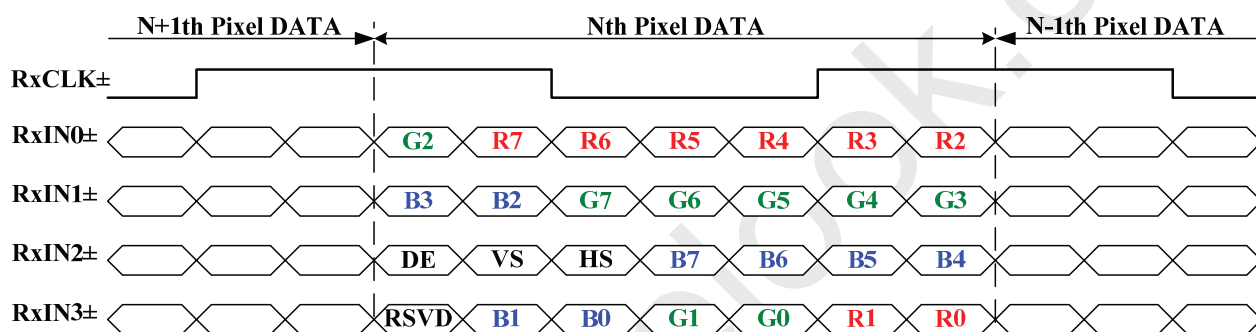

R0~R7: Pixel R DATA (R7:MSB, R0:LSB)
 G0~G7: Pixel G DATA (G7:MSB, G0:LSB)
 B0~B7: Pixel B DATA (B7:MSB, B0:LSB)
 DE: DATA enable Signal

4.4 COLOR DATA INPUT ASSIGNMENT

Colors & Gray scale	Data signal																								
	Gray Scale	R0	R1	R2	R3	R4	R5	R6	R7	G0	G1	G2	G3	G4	G5	G6	G7	B0	B1	B2	B3	B4	B5	B6	B7
Basic Color	Black	—	0	0	0	0	0	0	0	0	0	0	0	0	0	0	0	0	0	0	0	0	0	0	
	Blue	—	0	0	0	0	0	0	0	0	0	0	0	0	0	0	0	1	1	1	1	1	1	1	1
	Green	—	0	0	0	0	0	0	0	0	1	1	1	1	1	1	1	0	0	0	0	0	0	0	0
	Cyan	—	0	0	0	0	0	0	0	0	1	1	1	1	1	1	1	1	1	1	1	1	1	1	1
	Red	—	1	1	1	1	1	1	1	1	0	0	0	0	0	0	0	0	0	0	0	0	0	0	0
	Magenta	—	1	1	1	1	1	1	1	1	0	0	0	0	0	0	0	1	1	1	1	1	1	1	1
	Yellow	—	1	1	1	1	1	1	1	1	1	1	1	1	1	1	1	0	0	0	0	0	0	0	0
	White	—	1	1	1	1	1	1	1	1	1	1	1	1	1	1	1	1	1	1	1	1	1	1	1
Gray Scale of Red	Black	GS0	0	0	0	0	0	0	0	0	0	0	0	0	0	0	0	0	0	0	0	0	0	0	
	↑	GS1	1	0	0	0	0	0	0	0	0	0	0	0	0	0	0	0	0	0	0	0	0	0	
	Darker	GS2	0	1	0	0	0	0	0	0	0	0	0	0	0	0	0	0	0	0	0	0	0	0	
	↑	↓				↓						↓								↓					
	↓	↓				↓						↓								↓					
	Brighter	GS253	1	0	1	1	1	1	1	1	0	0	0	0	0	0	0	0	0	0	0	0	0	0	
	↓	GS254	0	1	1	1	1	1	1	1	0	0	0	0	0	0	0	0	0	0	0	0	0	0	
	Red	GS255	1	1	1	1	1	1	1	1	0	0	0	0	0	0	0	0	0	0	0	0	0	0	0
Gray Scale of Green	Black	GS0	0	0	0	0	0	0	0	0	0	0	0	0	0	0	0	0	0	0	0	0	0	0	
	↑	GS1	0	0	0	0	0	0	0	1	0	0	0	0	0	0	0	0	0	0	0	0	0	0	
	Darker	GS2	0	0	0	0	0	0	0	0	1	0	0	0	0	0	0	0	0	0	0	0	0	0	
	↑	↓				↓						↓								↓					
	↓	↓				↓						↓								↓					
	Brighter	GS253	0	0	0	0	0	0	0	0	1	0	1	1	1	1	1	0	0	0	0	0	0	0	
	↓	GS254	0	0	0	0	0	0	0	0	0	1	1	1	1	1	1	0	0	0	0	0	0	0	
	Green	GS255	0	0	0	0	0	0	0	0	1	1	1	1	1	1	1	0	0	0	0	0	0	0	0
Gray Scale of Blue	Black	GS0	0	0	0	0	0	0	0	0	0	0	0	0	0	0	0	0	0	0	0	0	0	0	
	↑	GS1	0	0	0	0	0	0	0	0	0	0	0	0	0	0	1	0	0	0	0	0	0	0	
	Darker	GS2	0	0	0	0	0	0	0	0	0	0	0	0	0	0	0	1	0	0	0	0	0	0	
	↑	↓				↓						↓								↓					
	↓	↓				↓						↓								↓					
	Brighter	GS253	0	0	0	0	0	0	0	0	0	0	0	0	0	0	1	0	1	1	1	1	1	1	
	↓	GS254	0	0	0	0	0	0	0	0	0	0	0	0	0	0	0	1	1	1	1	1	1	1	
	Blue	GS255	0	0	0	0	0	0	0	0	0	0	0	0	0	0	1	1	1	1	1	1	1	1	1

0: Low level voltage,

1: High level voltage.

Each basic color can be displayed in 256 gray scales from 8 bit data signals. According to the combination of total 24 bit data signals, the 16,7M colors display can be achieved on the screen.

4.5 BACKLIGHT INTERFACE CONNECTION

LED lightbar housing type : C10112S0000, manufactured by CVILUX Corp or equivalent. The mating connector is PH-12A, PH-12AW or equivalent.

Pin No.	Symbol	Description
1	LED+	Positive of LED String
2	NC	No connection
3	LED-	Negative of LED String
4	NC	No connection
5	LED-	Negative of LED String
6	NC	No connection
7	NC	No connection
8	LED-	Negative of LED String
9	NC	No connection
10	LED-	Negative of LED String
11	NC	No connection
12	LED+	Positive of LED String

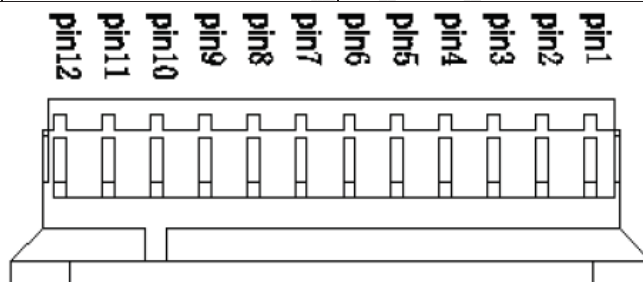

4.6 BACKLIGHT UNIT

The backlight unit contains one lightbar.

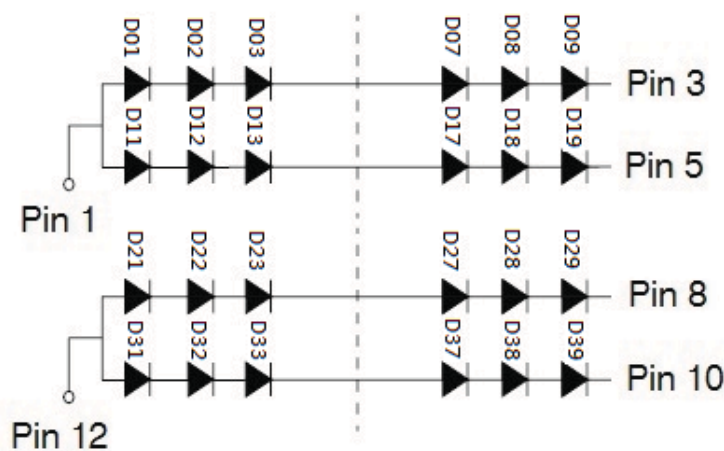

LED: $9 \times 4 = 36$ (pcs)

Electrical Circuit

5. INTERFACE TIMING

5.1 INPUT SIGNAL TIMING SPECIFICATIONS

The input signal timing specifications are shown as the following table and timing diagram.

Parameter		Symbol	Min	Typ.		Max.	Unit
				NTSC	PAL		
Clock	Frequency	Fclk=1/Tc	72	82	82	85	MHz
	Spread Spectrum Modulation range	Fclk_mod	Fclk-3%	-	-	Fclk+3%	MHz
	Spread Spectrum Modulation frequency	FSSM	30	-	-	100	KHz
Data enable signal	Horizontal period	TH	1540	1696	1696	1940	clock
			17.15	20.68	20.68	21.42	μs
	Horizontal period (High)	THd	1366	1366	1366	1366	clock
	Horizontal Blanking period	TH-THd	174	330	330	574	clock
	Vertical period	TV	778	806	967	972	line
			47.7	60	50	62.35	Hz
	Vertical period (High)	TVd	768	768	768	768	line
Vertical Blanking period	TV-TVd	10	38	199	204	line	

*Timing diagrams of input signal are shown in Fig. 7-1.

* SSCG (Spread spectrum clock generator) is defined as Fig. 7-2.

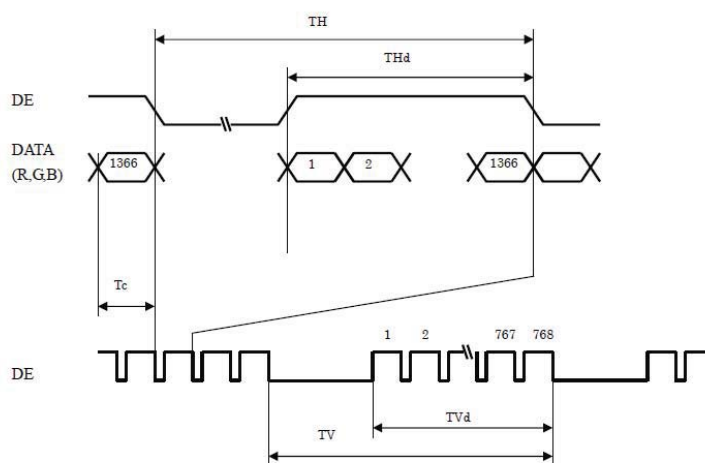

Fig.7-1 Timing characteristics of input signals

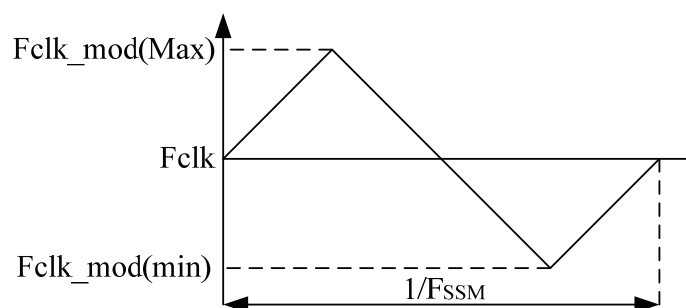
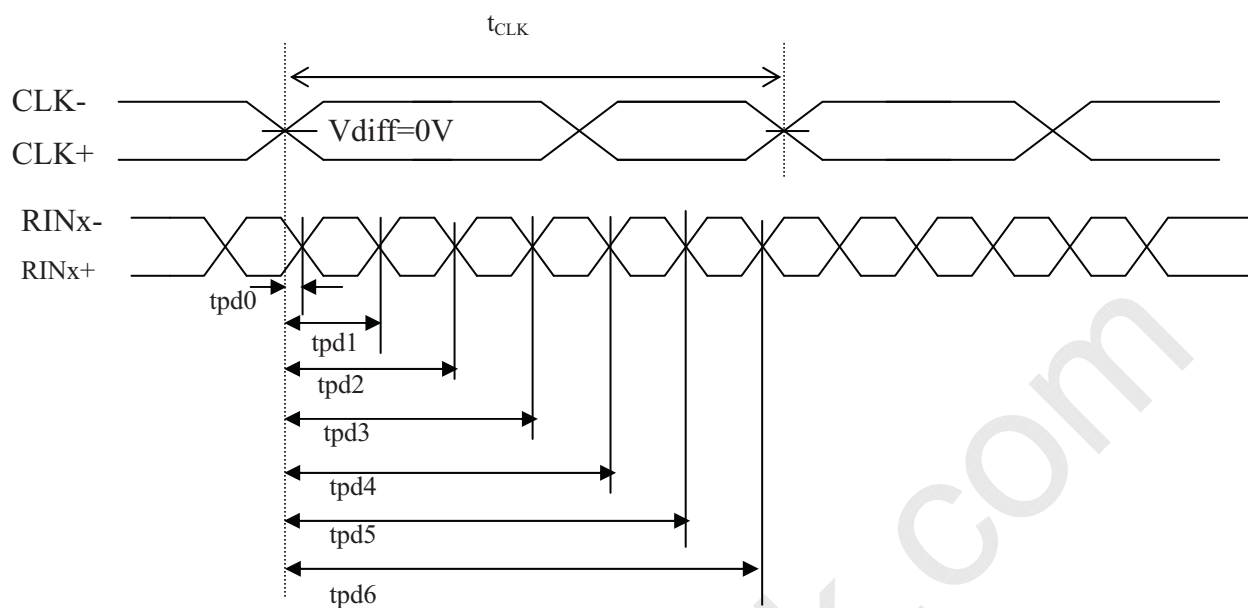

Fig.7-2 Spread spectrum clock generator

5.2 LVDS SIGNAL CHARACTERISTICS



LVDS signal characteristics

The item		Symbol	min.	typ.	Max.	unit
Data position	Delay time, CLK rising edge to serial bit position 0	tpd0	-0.40	0	0.40	ns
	Delay time, CLK rising edge to serial bit position 1	tpd1	typ-0.40	$1 * t_{CLK} / 7$	typ+0.40	
	Delay time, CLK rising edge to serial bit position 2	tpd2	typ-0.40	$2 * t_{CLK} / 7$	typ+0.40	
	Delay time, CLK rising edge to serial bit position 3	tpd3	typ-0.40	$3 * t_{CLK} / 7$	typ+0.40	
	Delay time, CLK rising edge to serial bit position 4	tpd4	typ-0.40	$4 * t_{CLK} / 7$	typ+0.40	
	Delay time, CLK rising edge to serial bit position 5	tpd5	typ-0.40	$5 * t_{CLK} / 7$	typ+0.40	
	Delay time, CLK rising edge to serial bit position 6	tpd6	typ-0.40	$6 * t_{CLK} / 7$	typ+0.40	

6. OPTICAL CHARACTERISTICS

6.1 OPTICAL SPECIFICATION

								Ta=25°C
Parameter		Symbol	Condition	Min.	Typ.	Max.	Unit	Remark
Luminance	Central Luminance	Lwc	$\theta = 0$ deg.	-	350	-	cd/m ²	[Note 1,4]
	Uniformity	ΔLw	$\theta = 0$ deg.	75	-	-	%	[Note 1,5]
Viewing angle range	Horizontal	$\theta 21$ $\theta 22$	CR \geq 10	-	88	-	Deg.	[Note 1,4]
	Vertical	$\theta 11$ $\theta 12$		-	88	-	Deg.	
Contrast ratio		CR	$\theta = 0$ deg.	-	5000	-	-	[Note 2,4]
Response time		τ_{DRV}		-	7	-	ms	[Note 3,4]
Chromaticity of white		x		Typ-0.03	0.280	Typ+0.03	-	[Note 4]
		y			0.290		-	
Chromaticity of red		x		TBD	-			
		y		TBD	-			
Chromaticity of green		x		TBD	-			
		y		TBD	-			
Chromaticity of blue		x		TBD	-			
		y		TBD	-			
Color Gamut		C.G.	-	TBD	-	%		

*The measurement shall be executed 30 minutes after lighting at rating.

*The optical characteristics are measured using the following equipment.

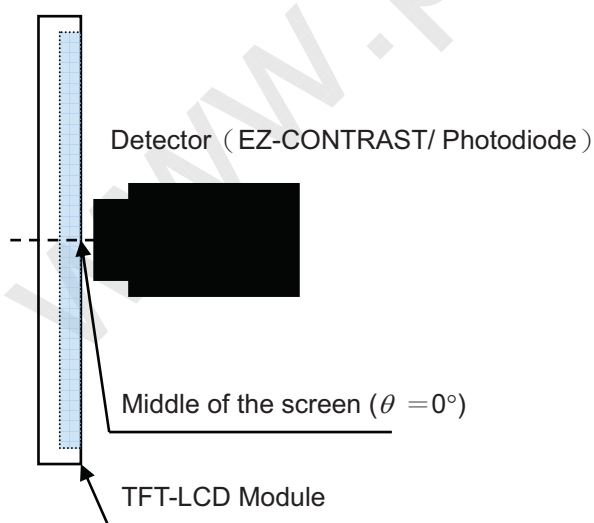

Measurement of viewing angle range, Response time.

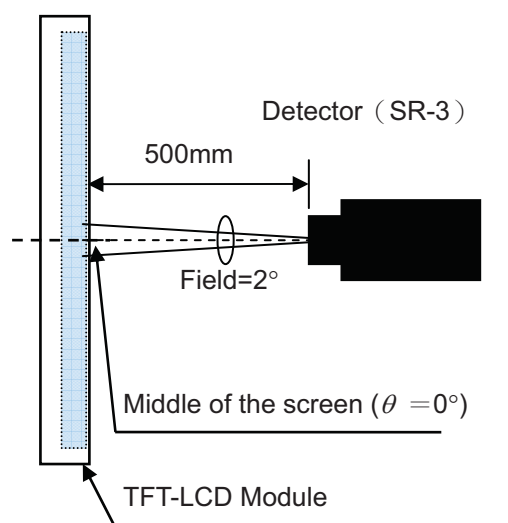

Measurement of Contrast, Luminance, Chromaticity.

[Note 1] Definitions of viewing angle range:

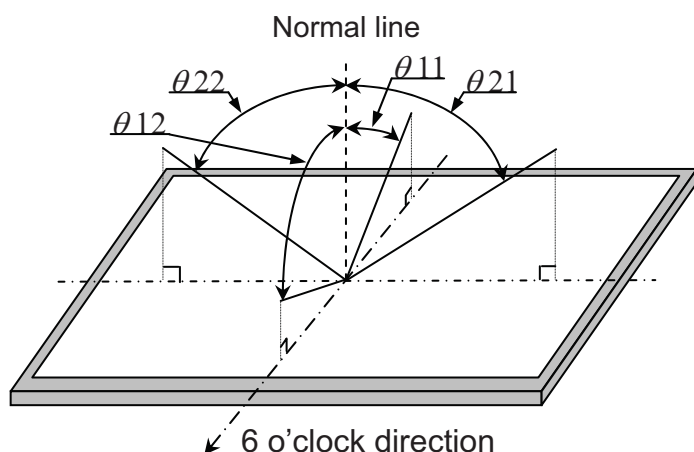

[Note 2] Definition of contrast ratio:

The contrast ratio is defined as the following.

$$\text{Contrast Ratio} = \frac{\text{Luminance (Brightness) with white screen}}{\text{Luminance (Brightness) with black screen}}$$

[Note 3] Definition of response time

The response time (τ_{DRV}) is defined as the following figure and shall be measured by switching the input signal for “any level of gray (0%, 25%, 50%, 75% and 100%) and “any level of gray (0%, 25%, 50%, 75% and 100%).

	0%	25%	50%	75%	100%
0%		$\tau_r:0\%-25\%$	$\tau_r:0\%-50\%$	$\tau_r:0\%-75\%$	$\tau_r:0\%-100\%$
25%	$\tau_d:25\%-0\%$		$\tau_r:25\%-50\%$	$\tau_r:25\%-75\%$	$\tau_r:25\%-100\%$
50%	$\tau_d:50\%-0\%$	$\tau_d:50\%-25\%$		$\tau_r:50\%-75\%$	$\tau_r:50\%-100\%$
75%	$\tau_d:75\%-0\%$	$\tau_d:75\%-25\%$	$\tau_d:75\%-50\%$		$\tau_r:75\%-100\%$
100%	$\tau_d:100\%-0\%$	$\tau_d:100\%-25\%$	$\tau_d:100\%-50\%$	$\tau_d:100\%-75\%$	

$\tau^*:x-y...$ response time from level of gray(x) to level of gray(y)

$$\tau_{DRV} = \Sigma (\tau^*:x-y)/20$$

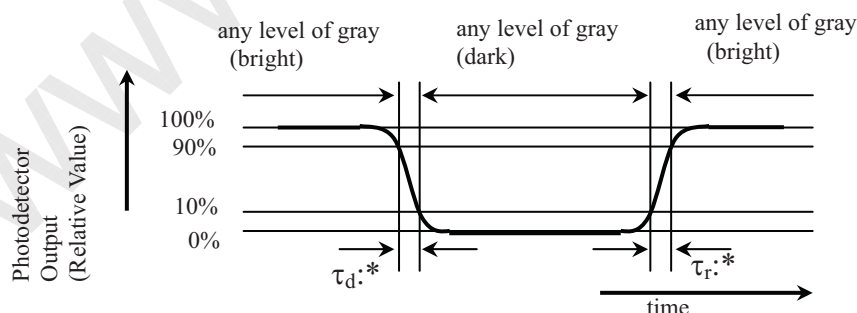

[Note 4] This shall be measured at center of the screen.

[Note 5] Definition of Luminance and Luminance uniformity:

Luminance: To measure at the center position “5” on the screen (NO.5).

Luminance uniformity: Lw (MAX) and Lw(MIN) are the maximum and minimum luminance value measure at the position “1~5” on the screen (NO.1~5) and the equation:

$$\Delta Lw = Lw(MIN) / Lw(MAX) \times 100\%$$

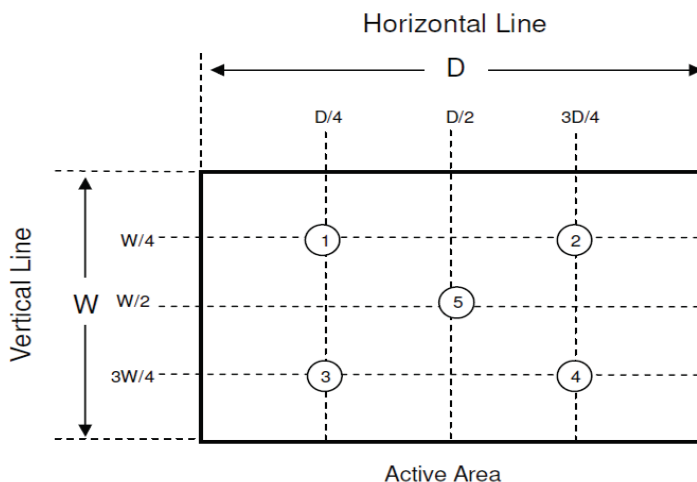

7. DEFINITION OF LABELS

7.1 MODULE LABEL

The label of displays, product model (LM315TU3A), and product label is stuck on the back side of the Module.

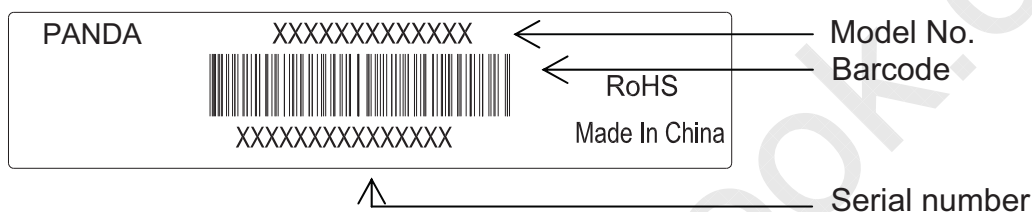

7.2 PACKING LABEL

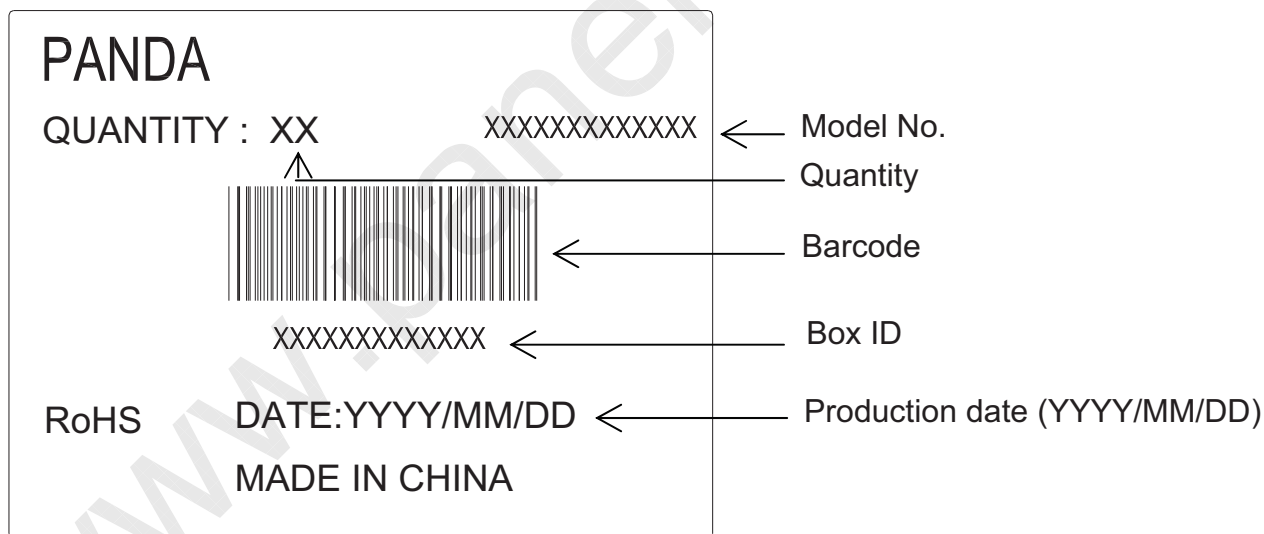

8. PACKING

8.1 PACKING SPECIFICATIONS

- a) Piling number of cartons : 6 Cartons / Pallet
- b) Packing quantity in one Carton : 12 pcs
- c) Packing size : 1558mm(W) × 900mm(D) × 1737mm(H)
- d) Total mass of one Pallet filled with full LCM : (TBD)

8.2 PACKING METHOD

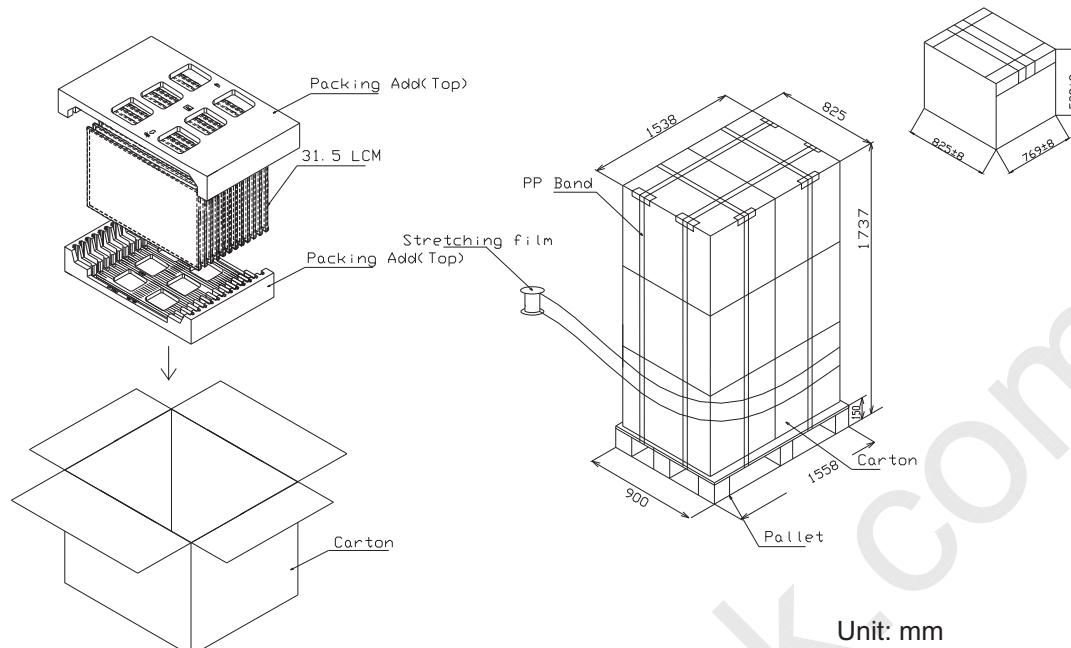

9. CARTON STORAGE CONDITION

Temperature: 0°C to 40°C

Humidity: 80%RH or less

Reference condition: 20°C to 35°C, 80%RH or less (summer)

5°C to 15°C, 80%RH or less (winter)

The total storage time (40°C, 80%RH): 240h or less

Sunlight Be sure to shelter a product from the direct sunlight.

Atmosphere Harmful gas, such as acid and alkali which bites electronic components and/or wires must not be detected.

Be sure to put cartons on pallet or base, don't put it on floor, and store them with removing from wall. Please take care of ventilation in storehouse and around cartons, and control changing temperature is within limits of natural environment.

10. PRECAUTIONS

10.1 ASSEMBLY AND HANDLING PRECAUTIONS

- Do not apply rough force such as bending or twisting to the module during assembly.
- It is recommended to assemble or to install a module into the user's system in clean working areas. The dust and oil may cause electrical short or worsen the polarizer.
- Since the LCM consists of TFT and electronic circuits with CMOS-ICs, which are very weak to electrostatic discharge, person who is handling an LCM should be grounded though adequate methods such as an anti-static wrist band. Connector pins should not be touched directly with bare hands.

Reference: Process control standard is shown as follow,

item	Management standard value and performance standard
1 Anti-static mat(shelf)	1to50 [Mega ohm]
2 Anti-static mat(floor, desk)	1to100 [Mega ohm]
3 Ionizer	Attenuate from $\pm 1000V$ to $\pm 100V$ within two seconds.
4 Anti-static wrist band	0.8 to 10 [Mega ohm]
5 Anti-static wrist band entry and ground resistance	Below 1000 [ohm]
6 Temperature	22 to 26 [°C]
7 Humidity	60 to 70 [%]

- Do not apply pressure or impulse to the module to prevent the damage of LCD panel and backlight.
- Always follow the correct power-on sequence when the LCD module is turned on. This can prevent the damage and latch-up of the CMOS LSI chips.
- Be sure to turn off the power supply when inserting or disconnecting the cable.

- (g) Do not disassemble the module.
- (h) Front polarizer can easily be damaged, so please pay attention on it.
- (i) Using a absorbent cotton or other soft cloth without chemicals for cleaning, because the surface of polarizer is very soft and easily scratched.
- (j) Since long contact with drops of water may cause discoloration or spots, please wipe off them as soon as possible.
- (k) The Panel will be broken or chipped when it is dropped or bumped against a hard substance.
- (l) Applying too much force and stress to PWBs and drivers may cause a malfunction electrically and mechanically.
- (m) Please be careful since image retention may occur when a fixed pattern is displayed for a long time.
- (n) Moisture can easily penetrate into LCD module and may cause the damage during operation.
- (o) High temperature or humidity may deteriorate the performance of LCD module. Please store LCD modules in the specified storage conditions.
- (p) This LCM is corresponded to ROHS.
- (q) When any question or issue occurs, it shall be solved by mutual discussion.

10.2 SAFETY PRECAUTIONS

- (a) If the liquid crystal material leaks from the panel, it should be kept away from the eyes or mouth. In case of contact with hands, skin or clothes, it has to be washed away thoroughly with soap.
- (b) After the module's end of life, it is not harmful in case of normal operation and storage.

11. RELIABILITY

- (a) Environment test condition

Test item	Condition
High temperature storage test	Ta= 60°C, 240h
Low temperature storage test	Ta= -20°C, 240h
High temperature and high humidity storage test	Ta= 50°C, 80%RH, 240h (No condensation)
High temperature operation test	Ta= 50°C, 240h
Low temperature operation test	Ta= 0°C,240h

- (b) Shock & Vibration

Test item	Condition
Shock (Non-Operation)	Shock level: 50 Grms Waveform: half sine wave, 11ms Direction: ±X,±Y,±Z One time each direction
Vibration (Non-Operation)	Wave form: Random Vibration level: 1.0 Grms Bandwidth: 10-200 Hz Duration: X,Y,Z, 30 min Each direction per 10 min

[Result evaluation criteria]

Under the display quality test condition with normal operation state, there shall be no change, which may affect practical display function.

12. MECHANICAL DRAWING

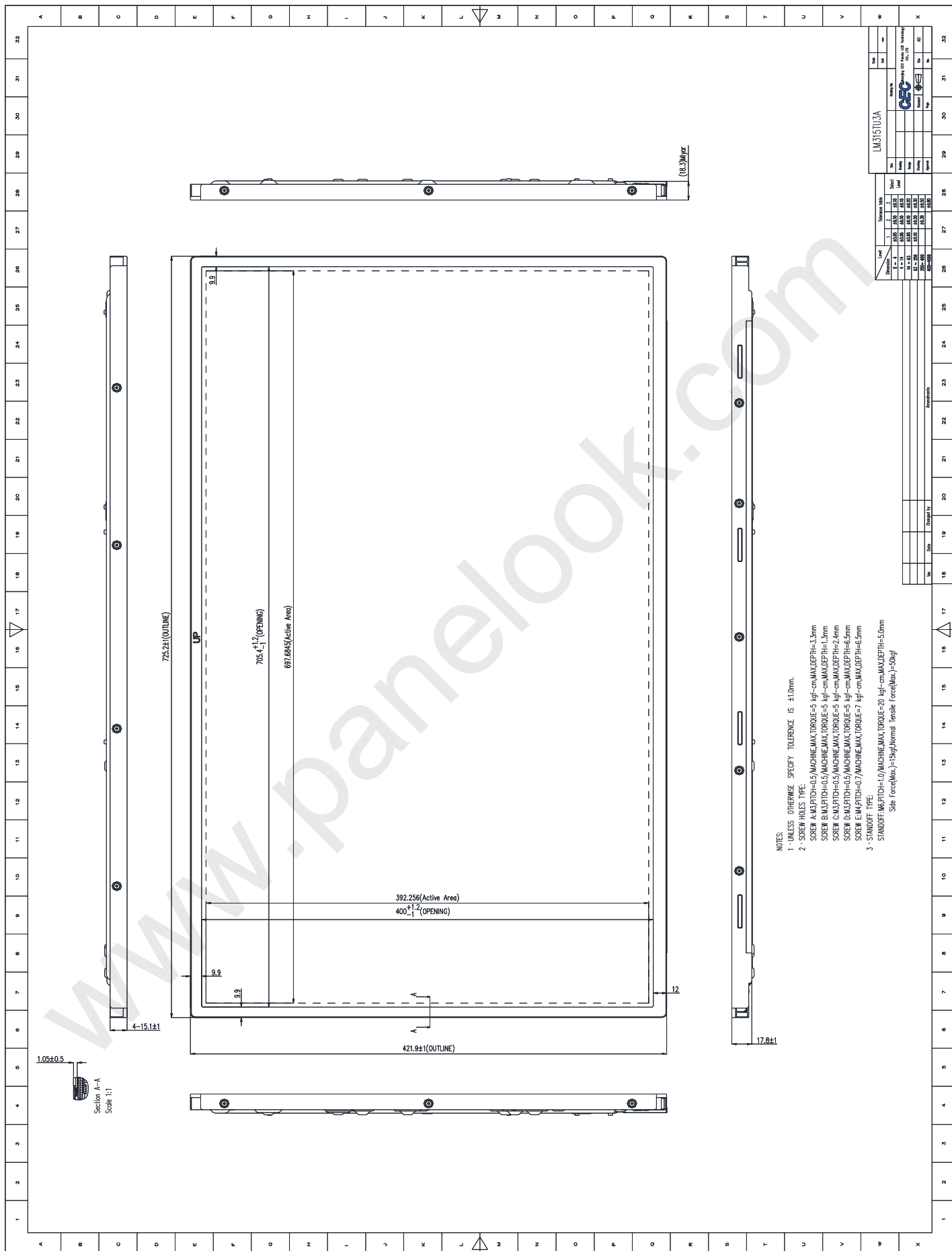
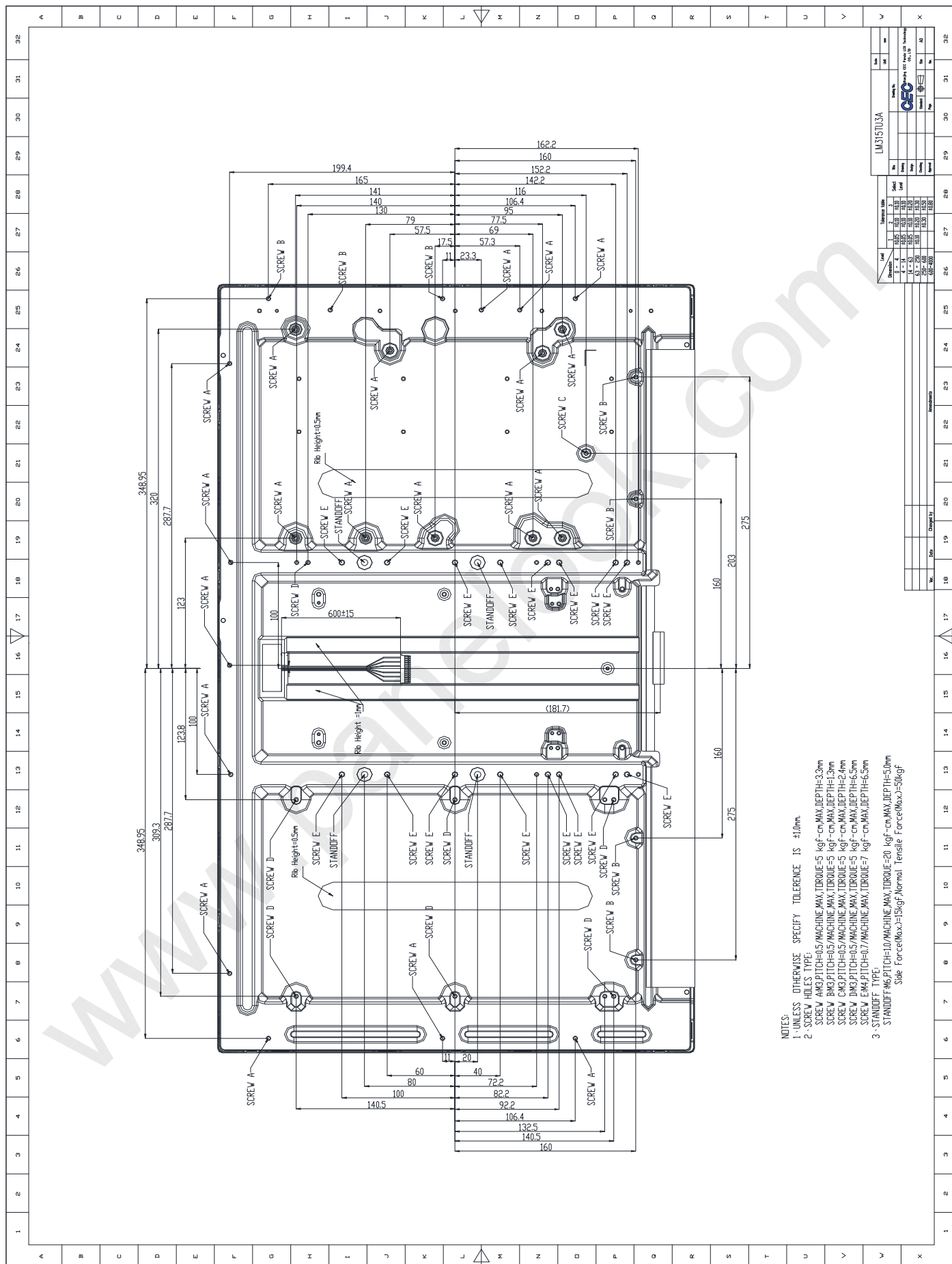

Fig.12-1. Front outline drawing



NOTES:
 1- UNLESS OTHERWISE SPECIFY TOLERANCE IS ±0.0mm.
 2- SCREW HOLES TYPE:
 SCREW A M3.0 PITCH=0.5/MACHINE MAX. TORQUE=5 kgf-cm MAX. DEPTH=3.0mm
 SCREW B M3.0 PITCH=0.5/MACHINE MAX. TORQUE=5 kgf-cm MAX. DEPTH=1.3mm
 SCREW C M3.0 PITCH=0.5/MACHINE MAX. TORQUE=5 kgf-cm MAX. DEPTH=2.4mm
 SCREW D M3.0 PITCH=0.5/MACHINE MAX. TORQUE=5 kgf-cm MAX. DEPTH=6.5mm
 SCREW E M3.0 PITCH=0.7/MACHINE MAX. TORQUE=7 kgf-cm MAX. DEPTH=6.5mm
 3- STANDOFF TYPE:
 STANDOFF M6.0 PITCH=1.0/MACHINE MAX. TORQUE=20 kgf-cm MAX. DEPTH=5.0mm
 Side Force(Max.)=50kgf/Normal Tensile Force(Max.)=50kgf

Fig.12-2. Rear outline drawing