

SPECIFICATION FOR APPROVAL

- (●) Preliminary Specification
- () Final Specification

Title	31.5" UHD TFT LCD
-------	-------------------

BUYER	
MODEL	

SUPPLIER	LG Display Co., Ltd.
*MODEL	LM315WR1
SUFFIX	SSA1

*When you obtain standard approval,
please use the above model name without suffix

SIGNATURE	DATE
/	_____
/	_____
/	_____

Please return 1 copy for your confirmation
With your signature and comments.

APPROVED BY	DATE
K.W. Kweon / G.Manager	_____
REVIEWED BY	
G.J. Han / Manager [C]	_____
Y.S. Jeong / Manager [M]	_____
T.H. Shin / Manager [P]	_____
PREPARED BY	
S.H. Lee / Engineer	_____

Product Engineering Dept.
LG Display Co., Ltd

Product Specification
Contents

No	ITEM	Page
	COVER	1
	CONTENTS	2
	RECORD OF REVISIONS	3
1	GENERAL DESCRIPTION	4
2	ABSOLUTE MAXIMUM RATINGS	5
3	ELECTRICAL SPECIFICATIONS	6
3-1	ELECTRICAL CHARACTREISTICS	6
3-2	INTERFACE CONNECTIONS	9
3-3	eDP SIGNAL SPECIFICATIONS	11
3-4	SIGNAL TIMING SPECIFICATIONS	15
3-5	SIGNAL TIMING WAVEFORMS	16
3-6	COLOR INPUT DATA REFERENCE	17
3-7	POWER SEQUENCE & DIP CONDITION FOR LCD MODULE	18
4	OPTICAL SPECIFICATIONS	20
5	MECHANICAL CHARACTERISTICS	26
6	RELIABILITY	29
7	INTERNATIONAL STANDARDS	30
7-1	SAFETY	30
7-2	EMC	30
7-3	ENVIRONMENT	30
8	PACKING	31
8-1	DESIGNATION OF LOT MARK	31
8-2	PACKING FORM	31
9	PRECAUTIONS	32

Product Specification

RECORD OF REVISIONS

Revision No	Revision Date	Page	Description
0.0	Dec. 07. 2015	-	First Draft, Preliminary Specifications

Ultratronik 04.08.2016

Product Specification
1. General Description

LM315WR1 is a Color Active Matrix Liquid Crystal Display with a Light Emitting Diode (WLED) backlight system without LED driver. The matrix employs a-Si Thin Film Transistor as the active element. It is a transmissive type display operating in the normally black mode. It has a 27 inch diagonally measured active display area with UHD resolution (3840 horizontal by 2160 vertical pixel array) Each pixel is divided into Red, Green and Blue sub-pixels or dots which are arranged in vertical stripes. Gray scale or the brightness of the sub-pixel color is determined with a 10-bit gray scale signal for each dot, thus, presenting a palette of more than 1.07Billion colors with A-FRC (Advanced Frame Rate Control).

It has been designed to apply eDP(HBR2, 5.4Gbps) interface.

It is intended to support displays where high brightness, super wide viewing angle, high color saturation, and high color are important.

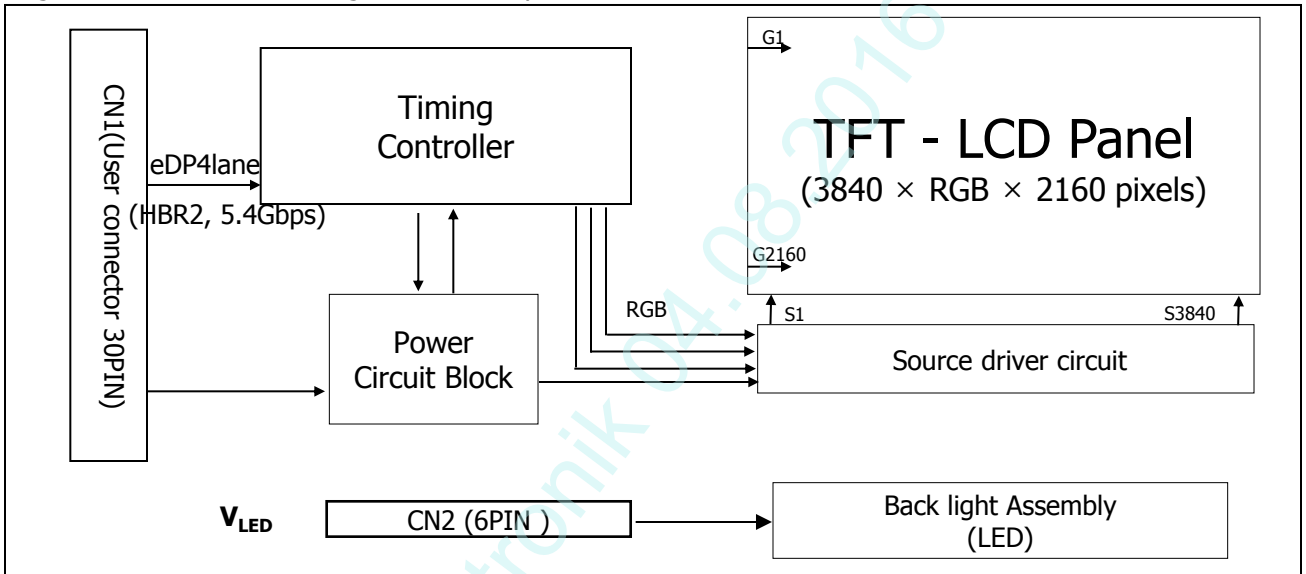

[FIG.1] Block diagram

General Features

Active Screen Size	31.5 inches(80.0051cm) (Aspect ratio 16:9)
Outline Dimension	309.2(H) x 405.1(V) x 13.6(D) mm (Typ.)
Pixel Pitch	0.06053(H) x 0.18159(V) mm
Pixel Format	3840(H) x 2160(V) Pixels. Pixels RGB stripes arrangement
Color Depth	1.07 Billion colors, 10 Bit (8Bit + A-FRC)
Luminance, White	350 cd/m ² (Center 1 Point, Typ.)
Viewing Angle(CR>10)	View Angle Free (R/L 178(Typ.), U/D 178(Typ.))
Power Consumption	Total 32.4W(Typ.) (10.0W @ V _{LCD} 22.4W @ Is=100mA)
Weight	Typ : TBD
Display Operating Mode	Transmissive mode, normally black
Panel type	Reverse type
Surface Treatment	Anti-glare treatment of the front polarizer (Haze 25%, 3H)

Product Specification

2. Absolute Maximum Ratings

The following are maximum values which, if exceeded, may cause faulty operation or damage to the unit.

Table 1. ABSOLUTE MAXIMUM RATINGS

Parameter	Symbol	Values		Units	Notes
		Min	Max		
Power Input Voltage	V _{LCD}	-0.3	12	Vdc	at 25 ± 2°C
Operating Temperature	T _{OP}	0	50	°C	

Ultratronik 04.08.2016

Product Specification

3. Electrical Specifications

3-1. Electrical Characteristics

It requires two power inputs. One is employed to power the LCD electronics and to drive the TFT array and liquid crystal. The second input power for the LED/Backlight, is typically generated by a LED Driver. The LED Driver is an external unit to the LCDs.

Table 2-1. ELECTRICAL CHARACTERISTICS

Parameter	Symbol	Values			Unit	Notes
		Min	Typ	Max		
MODULE :						
Power Supply Input Voltage	V _{LCD}	9.5	10.0	10.5	Vdc	5
Permissive Power Input Ripple	V _{dRF}			400	mV _{p-p}	1
Power Supply Input Current	I _{LCD}	-	(1000)	(1250)	mA	2
		-	(1350)	(1680)	mA	3
Power Consumption	P _c TYP	-	(10)	(12.5)	Watt	2
	P _c MAX	-	(13.5)	(16.8)	Watt	3
Rush current	I _{RUSH}	-		3	A	4

Note :

1. Permissive power ripple should be measured under V_{LCD}=10.0V, 25 ± 2°C, f_V=60Hz condition and at that time, we recommend the bandwidth configuration of oscilloscope is to be under 20Mhz.
2. The specified current and power consumption are under the V_{LCD}=10.0V, 25 ± 2°C, f_V=60Hz condition whereas mosaic pattern(8 × 6) is displayed and f_V is the frame frequency.
3. The current is specified at the maximum current pattern.
4. The duration of rush current is about 2ms and rising time of power Input is 1ms(min.).
5. V_{LCD} level must be measured at two points on LCM PCB - between V_{LCD}(test point) and LCM Ground. The measured results need to meet the Power supply input voltage spec.
(Test condition : maximum power pattern , 25± 2°C, f_V=60Hz)

Product Specification

- **Permissive Power input ripple** ($V_{LCD} = 10.0V$, $25^{\circ}C$, f_v (frame frequency)=Max. condition)

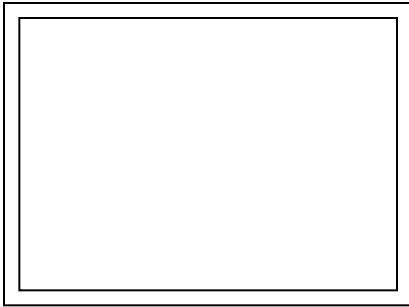

White pattern



Black pattern

- **Power consumption** ($V_{LCD} = 10V$, $25^{\circ}C$, f_v (frame frequency)=60Hz condition)

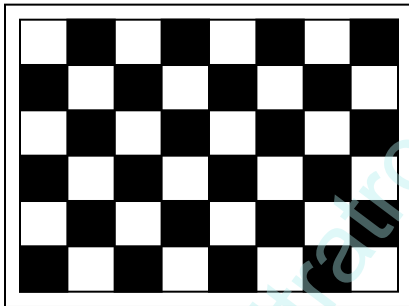

Typical power Pattern

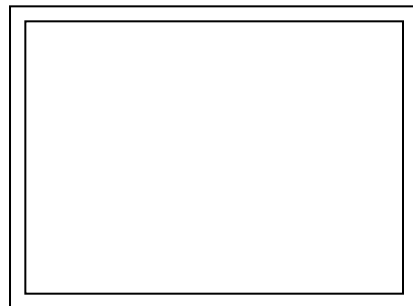

Maximum power Pattern

FIG.3 Mosaic pattern & White Pattern for power consumption measurement

Product Specification
Table 2-2. LED Bar ELECTRICAL CHARACTERISTICS

Parameter	Symbol	Values			Unit	Notes
		Min.	Typ.	Max.		
LED String Current	Is	-	(100)	(105)	mA	1, 2, 5
LED String Voltage	Vs	TBD	(56.1)	TBD	V	1, 5
Power Consumption	PBar	-	(22.4)	TBD	Watt	2, 4
LED Life Time	LED_LT	30,000	-	-	Hrs	3

Notes) The LED Bar consists of 68ea LED packages, 4 strings (parallel) x 17 packages (serial)

LED driver design guide

- 1) The design of the LED driver must have specifications for the LED in LCD Assembly.
 The performance of the LED in LCM, for example life time or brightness, is extremely influenced by the characteristics of the LED driver.
 So all the parameters of an LED driver should be carefully designed and output current should be Constant current control.
 Please control feedback current of each string individually to compensate the current variation among the strings of LEDs.
 When you design or order the LED driver, please make sure unwanted lighting caused by the mismatch of the LED and the LED driver (no lighting, flicker, etc) never occurs.
 When you confirm it, the LCD module should be operated in the same condition as installed in your instrument.
- 2) LGD strongly recommend Analog Dimming method for Backlight Brightness control for Wavy Noise Free. Otherwise, recommend that Dimming Control Signal (PWM Signal) should be synchronized with Frame Frequency.

1. The specified values are for a single LED bar .
2. The specified current is defined as the input current for a single LED string with 100% duty cycle.
3. The LED life time is defined as the time when brightness of LED packages become 50% or less than the initial value under the conditions at $T_a = 25 \pm 2^\circ\text{C}$ and LED string current is typical value.
4. The power consumption shown above does not include loss of external driver.
 The typical power consumption is calculated as $P_{\text{Bar}} = V_s(\text{Typ.}) \times I_s(\text{Typ.}) \times \text{No. of strings}$.
 The maximum power consumption is calculated as $P_{\text{Bar}} = V_s(\text{Max.}) \times I_s(\text{Typ.}) \times \text{No. of strings}$.
5. LED operating conditions are must not exceed Max. ratings.

Product Specification

3-2. Interface Connections

3-2-1. LCD Module

- LCD Connector(CN1) : GT05Q-30S-H10-MN (LSMtron), HD2S030HA1 (JAE), KN38B-30S-0.5H(HIROSE) or Equivalent

Table 3. MODULE CONNECTOR(CN1) PIN CONFIGURATION

No	Symbol	Description	No	Symbol	Description
1	VLCD	Power Supply +10.0V	16	Lane0P	True Signal for Main Link 0
2	VLCD	Power Supply +10.0V	17	Lane0N	Component Signal for Main Link 0
3	VLCD	Power Supply +10.0V	18	GND	Ground
4	VLCD	Power Supply +10.0V	19	Lane1P	True Signal for Main Link 1
5	VLCD	Power Supply +10.0V	20	Lane1N	Component Signal for Main Link 1
6	NC	No connection	21	GND	Ground
7	GND	Ground	22	Lane2P	True Signal for Main Link 2
8	NC	No Connection	23	Lane2N	Component Signal for Main Link 2
9	NC	No Connection	24	GND	Ground
10	GND	Ground	25	Lane3P	True Signal for Main Link 3
11	HPD	Hot Plug Detect Signal	26	Lane3N	Component Signal for Main Link 3
12	GND	Ground	27	GND	Ground
13	AUX_CHN	Component Signal for Auxiliary Channel	28	NC	No Connection
14	AUX_CHP	True Signal for Auxiliary Channel	29	NC	No Connection
15	GND	Ground	30	NC	No Connection

- Note:
1. All GND(ground) pins should be connected together and to Vss which should also be connected to the LCD's metal frame.
 2. All VLCD (power input) pins should be connected together.

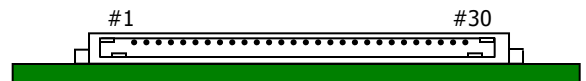
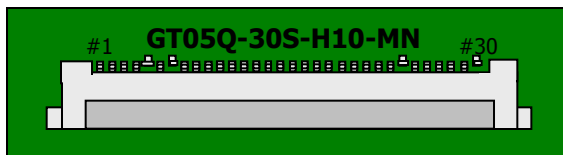

Rear view of LCM

FIG.4 Connector diagram

Product Specification

3-2-2. BACKLIGHT CONNECTOR PIN CONFIGURATION(CN2)

The LED interface connector is a model SM06B-SHJH(HF)_Manufactured by JST or equivalent.
The mating connector is a SHJP-06V-S(HF), SHJP-06V-A-K(HF) or equivalent.
The pin configuration for the connector is shown in the table below.

Table 3-1. LED CONNECTOR PIN CONFIGURATION

Pin	Symbol	Description	Remark	Pin	Symbol	Description	Remark
1	FB2	Channel2 Current Feedback	Left bar	1	FB2	Channel2 Current Feedback	Right bar
2	NC	NC		2	NC	NC	
3	VLED	LED Power Supply		3	VLED	LED Power Supply	
4	VLED	LED Power Supply		4	VLED	LED Power Supply	
5	NC	NC		5	NC	NC	
6	FB1	Channel1 Current Feedback		6	FB1	Channel1 Current Feedback	

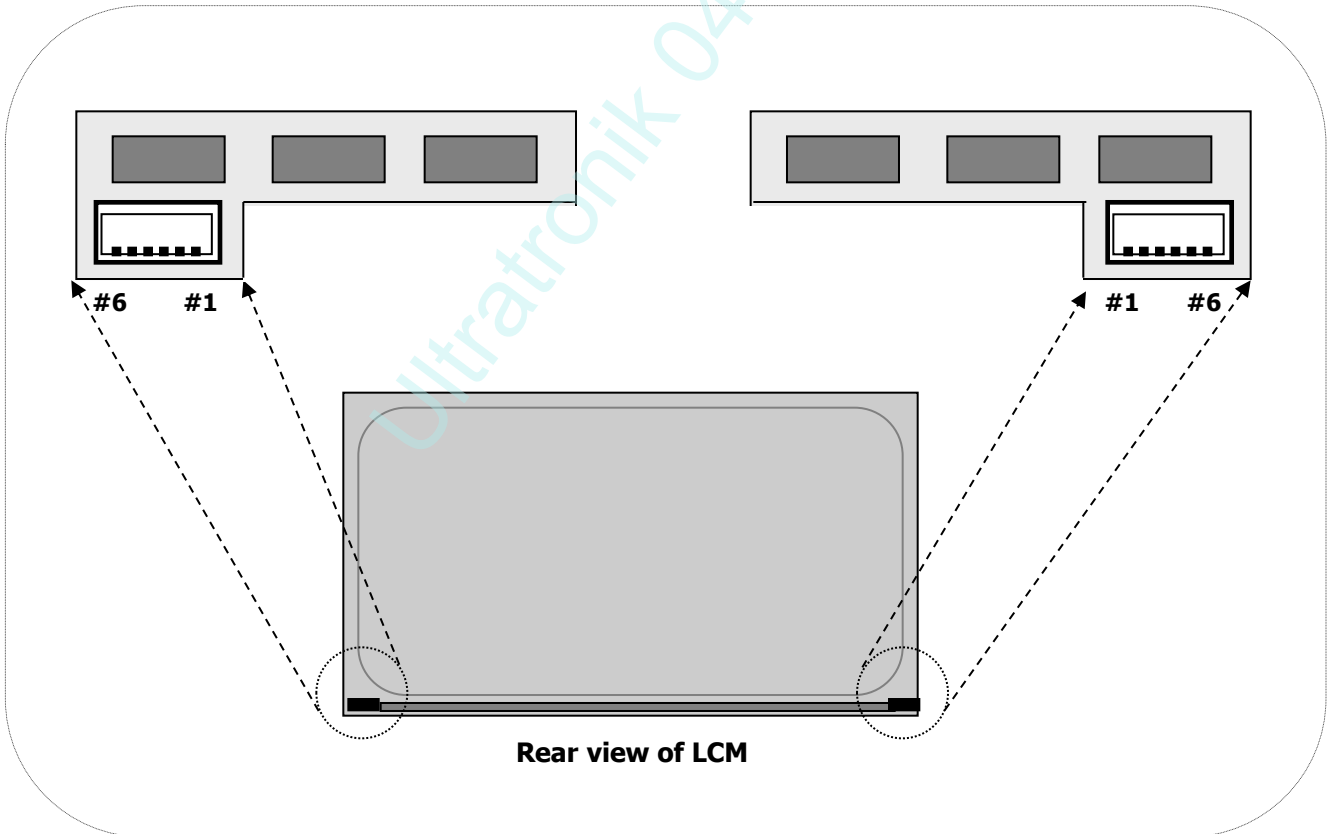

[FIG. 5] Backlight connector view

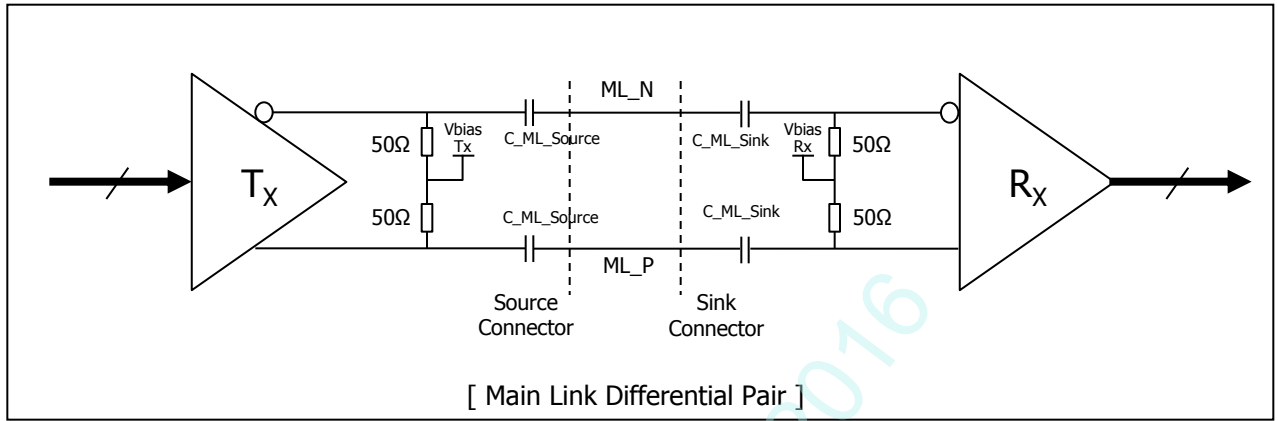
Product Specification
3-3. eDP Signal Specifications
3-3-1. eDP Main Link Signal

Parameter	Symbol	Min	Typ	Max	Unit	Notes
Unit Interval for high bit rate (5.4Gbps / lane)	UI_HBR2	-	185	-	ps	
Link Clock Down Spreading	Amplitude	0	-	0.5	%	
	Frequency	30		33	kHz	
Differential peak-to-peak voltage at Sink side connector	$V_{RX-DIFFP-P}$	-	-	1.38	V	Note 6,7)
EYE width at Sink side connector	$T_{RX-EYE-CONN}$	0.38	-	-	UI	Note 6,7)
Lane-to-Lane skew	$L_{RX-SKEW-INTER_PAIR}$	-	-	4UI+ 500ps		
Lane intra-pair skew	$L_{RX-SKEW-INTRA_PAIR}$	-	-	50	ps	
AC Coupling Capacitor	$C_{SOURCE-ML}$	75		200	nF	Source side

Note)

1. Termination resistor is typically integrated into the transmitter and receiver implementations.
2. In cabled embedded system, it is recommended the system designer ensure that EYE width and voltage are met at the sink side connector pins.
3. Mismatched common mode voltage will occur abnormal display.
4. All eDP electrical spec is measured at sink connector side.
5. eDP cable Impedance should be 100ohm \pm 5%.

Product Specification

Note6) Definition of Differential Voltage

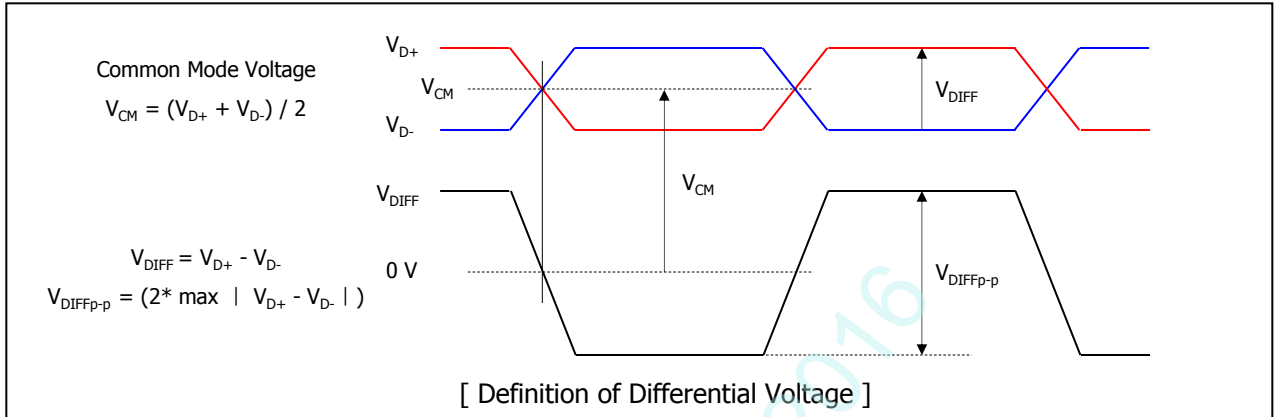

Note7) Main Link EYE Diagram

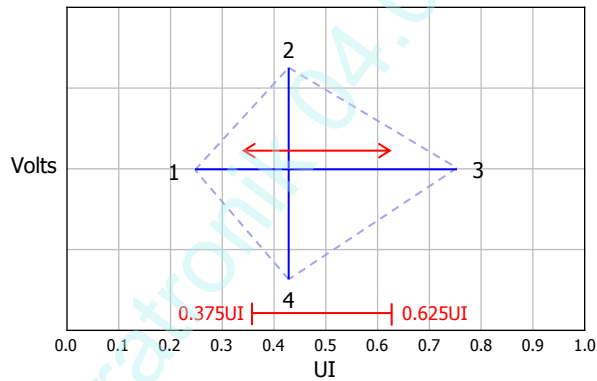

Point	High Bit Rate 2 @ TP3 EQ	
	Time(UI)	Voltage(V)
1	Any UI location (x) where the eye width is open from x to x+0.38UI	0.000
2	Any passing UI location between 0.375UI-0.625UI	0.045
3	Point 1 + 0.38UI	0.000
4	Same as Point 2	-0.045

[EYE Mask Vertices at embedded DP Sink Connector Pins]

Product Specification

3-3-2. eDP AUX Channel Signal

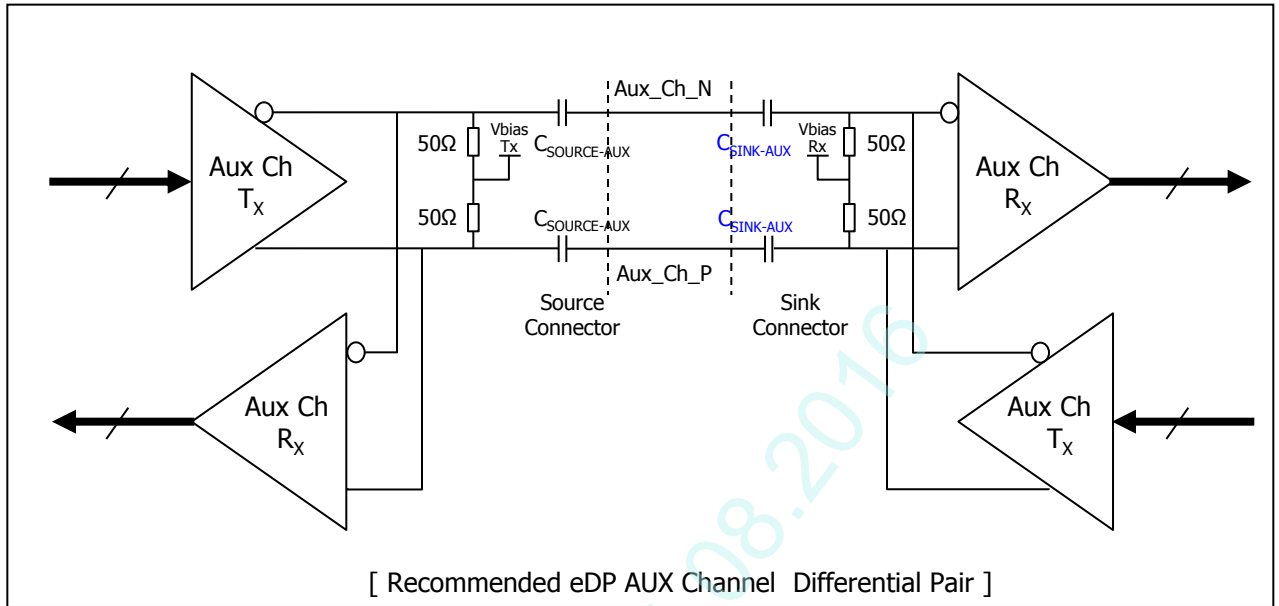

Parameter	Symbol	Min	Typ	Max	Unit	Notes
AUX Unit Interval	UI	0.4	-	0.6	us	
AUX Jitter at Tx IC Package Pins	T_{jitter}	-	-	0.04	UI	Equal to 24ns
AUX Jitter at Rx IC Package Pins		-	-	0.05	UI	Equal to 30ns
AUX Peak-to-peak voltage at Connector Pins of Receiving	$V_{AUX-DIFFp-p}$	0.32	-	1.36	V	
AUX Peak-to-peak voltage at Connector Pins of Transmitting		0.39	-	1.38	V	
AUX EYE width at Connector Pins of Tx and Rx		0.98	-	-	UI	
AUX DC common mode voltage	V_{AUX-CM_Rx}	-	0	2.0	V	
	V_{AUX-CM_Tx}	-	0.15	2.0	V	
AUX AC Coupling Capacitor	$C_{SOURCE-AUX}$	75		200	nF	Source side

Note)

1. Termination resistor is typically integrated into the transmitter and receiver implementations.
2. $V_{AUX-DIFFp-p} = 2 * |V_{AUXP} - V_{AUXN}|$
3. Termination resistor should be $\pm 50\Omega$ at source side to AUX level.
4. At sink side AUX cap. are for protection ESD/EOS damage.
5. Mismatched common mode voltage will occur abnormal display.

Product Specification

3-3-3. eDP HPD Signal

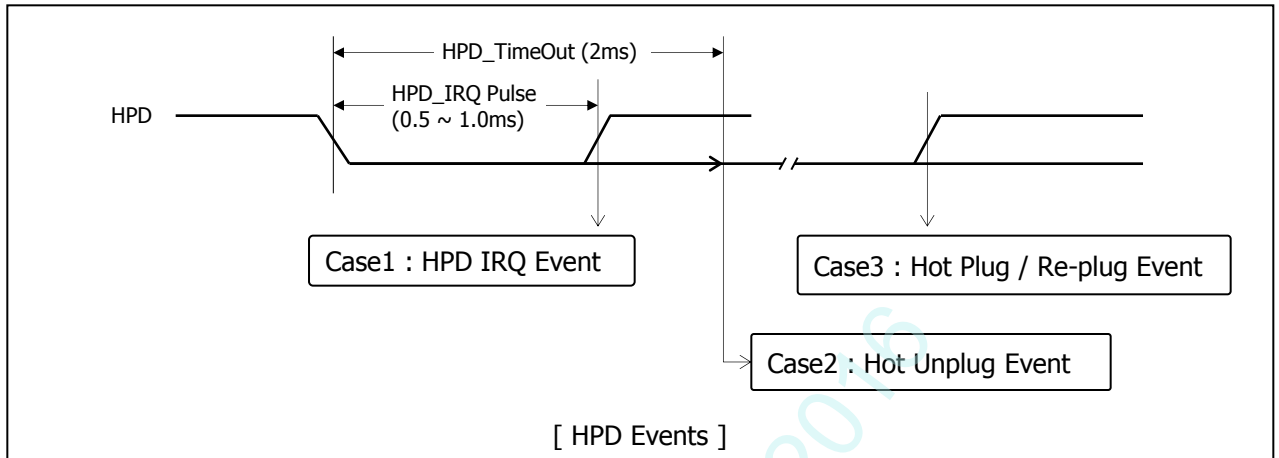

Parameter	Symbol	Min	Typ	Max	Unit	Notes
HPD Voltage	HPD	2.25	-	3.6	V	Sink side Driving
Hot Plug Detection Threshold		2.0	-	-	V	Source side Detecting
Hot Unplug Detection Threshold		-	-	0.8	V	
HPD_IRQ Pulse Width	HPD_IRQ	0.5	-	1.0	ms	
HPD_TimeOut		2.0	-	-	ms	HPD Unplug Event

Note)

1. HPD IRQ : Sink device wants to notify the Source device that Sink's status has changed so it toggles HPD line, forcing the Source device to read its Link / Sink Receiver DPCD field via the AUX-CH
2. HPD Unplug : The Sink device is no longer attached to the Source device and the Source device may then disable its Main Link as a power saving mode
3. Plug / Re-plug : The Sink device is now attached to the Source device, forcing the Source device to read its Receiver capabilities and Link / Sink status Receiver DPCD fields via the AUX-CH

Product Specification
3-4. Signal Timing Specifications

This is signal timing required at the input of the TMDS transmitter. All of the interface signal timing should be satisfied with the following specifications for its proper operation.

Table 4. TIMING TABLE

ITEM		SYMBOL	Min	Typ	Max	Unit	Note
DCLK	Period	tCLK		1.9		ns	
	Frequency	fCLK		533.25		MHz	-
Hsync	Period	tHP		4000		tCLK	
	Width-Active	tWH		32			
Vsync	Period	tVP		2222		tHP	
	Frequency	fV		59.997		Hz	
	Width-Active	tWV		5		tHP	
Data Enable	Horizontal Valid	tHV		3840		tCLK	
	Horizontal Back Porch	tHBP		80			
	Horizontal Front Porch	tHFP		48			
	Horizontal Blank	-		160			tWH+ tHBP+ tHFP
	Vertical Valid	tVV		2160		tHP	
	Vertical Back Porch	tVBP		54			
	Vertical Front Porch	tVFP		3			
Vertical Blank	-		62				tWV+ tVBP+ tVFP

Note:

1. DE Only mode operation. The input of Hsync & Vsync signal does not have an effect on LCD normal operation.
2. The performance of the electro-optical characteristics may be influenced by variance of the vertical refresh rates.
3. Horizontal period should be even.

Product Specification

3-5. Signal Timing Waveforms

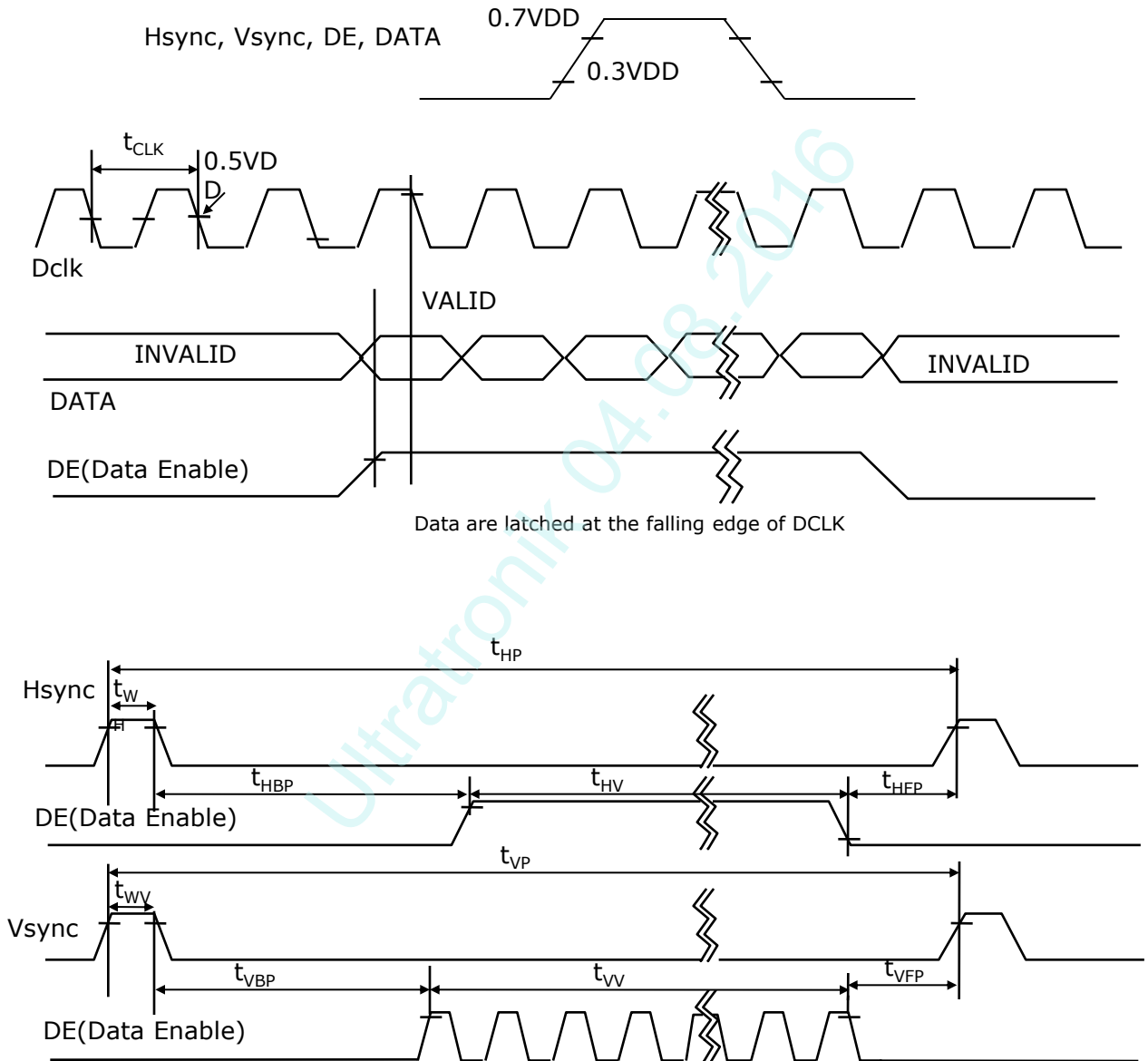

Product Specification
3-6. Color Input Data Reference

The Brightness of each primary color(red,green,blue) is based on the 10-bit gray scale data input for the color; the higher the binary input, the brighter the color. The table below provides a reference for color versus data input.

Table 5. COLOR DATA REFERENCE

Color		Input Color Data																													
		RED										GREEN										BLUE									
		MSB					LSB					MSB					LSB					MSB				LSB					
		R9	R8	R7	R6	R5	R4	R3	R2	R1	R0	G9	G8	G7	G6	G5	G4	G3	G2	G1	G0	B9	B8	B7	B6	B5	B4	B3	B2	B1	B0
Basic Color	Black	0	0	0	0	0	0	0	0	0	0	0	0	0	0	0	0	0	0	0	0	0	0	0	0	0	0	0	0	0	0
	Red (1023)	1	1	1	1	1	1	1	1	1	1	0	0	0	0	0	0	0	0	0	0	0	0	0	0	0	0	0	0	0	0
	Green (1023)	0	0	0	0	0	0	0	0	0	0	1	1	1	1	1	1	1	1	1	1	0	0	0	0	0	0	0	0	0	0
	Blue (1023)	0	0	0	0	0	0	0	0	0	0	0	0	0	0	0	0	0	0	0	0	1	1	1	1	1	1	1	1	1	1
	Cyan	0	0	0	0	0	0	0	0	0	0	1	1	1	1	1	1	1	1	1	1	1	1	1	1	1	1	1	1	1	1
	Magenta	1	1	1	1	1	1	1	1	1	1	0	0	0	0	0	0	0	0	0	0	1	1	1	1	1	1	1	1	1	1
	Yellow	1	1	1	1	1	1	1	1	1	1	1	1	1	1	1	1	1	1	1	1	0	0	0	0	0	0	0	0	0	0
	White	1	1	1	1	1	1	1	1	1	1	1	1	1	1	1	1	1	1	1	1	1	1	1	1	1	1	1	1	1	1
RED	RED (000)	0	0	0	0	0	0	0	0	0	0	0	0	0	0	0	0	0	0	0	0	0	0	0	0	0	0	0	0	0	
	RED (001)	0	0	0	0	0	0	0	0	0	0	0	0	0	0	0	0	0	0	0	0	0	0	0	0	0	0	0	0	0	
		
	RED (1022)	1	1	1	1	1	1	1	1	1	0	0	0	0	0	0	0	0	0	0	0	0	0	0	0	0	0	0	0	0	
	RED (1023)	1	1	1	1	1	1	1	1	1	0	0	0	0	0	0	0	0	0	0	0	0	0	0	0	0	0	0	0	0	
GREEN	GREEN (000)	0	0	0	0	0	0	0	0	0	0	0	0	0	0	0	0	0	0	0	0	0	0	0	0	0	0	0	0	0	
	GREEN (001)	0	0	0	0	0	0	0	0	0	0	0	0	0	0	0	0	0	0	0	0	0	0	0	0	0	0	0	0	0	
			
	GREEN (1022)	0	0	0	0	0	0	0	0	0	1	1	1	1	1	1	1	1	1	1	0	0	0	0	0	0	0	0	0	0	
	GREEN (1023)	0	0	0	0	0	0	0	0	0	1	1	1	1	1	1	1	1	1	1	0	0	0	0	0	0	0	0	0	0	
BLUE	BLUE (000)	0	0	0	0	0	0	0	0	0	0	0	0	0	0	0	0	0	0	0	0	0	0	0	0	0	0	0	0	0	
	BLUE (001)	0	0	0	0	0	0	0	0	0	0	0	0	0	0	0	0	0	0	0	0	0	0	0	0	0	0	0	0	1	
			
	BLUE (1022)	0	0	0	0	0	0	0	0	0	0	0	0	0	0	0	0	0	0	0	1	1	1	1	1	1	1	1	1	0	
	BLUE (1023)	0	0	0	0	0	0	0	0	0	0	0	0	0	0	0	0	0	0	0	1	1	1	1	1	1	1	1	1	1	

Product Specification

3-7. Power Sequence

3-7-1. Power Sequence

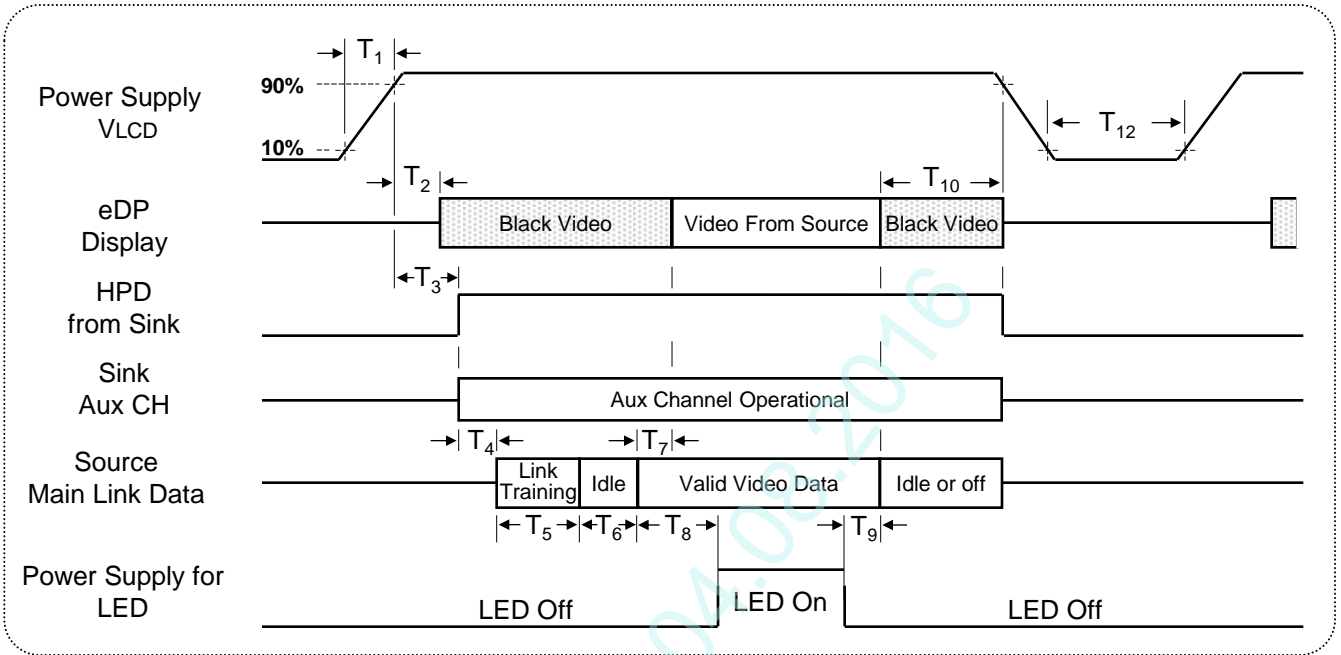

Table 6. POWER SEQUENCE TABLE

Timing	Required By	Limits		Units	Notes
		Min	Max		
T ₁	Source	0.5	10	ms	-
T ₂	Sink	10	200	ms	-
T ₃	Sink	15	200	ms	-
T ₄	Source	-	-	ms	6
T ₅	Source	-	-	ms	6
T ₆	Source	-	100	ms	-
T ₇	Sink	0	50	ms	-
T ₈	Source	200	-	ms	
T ₉	Source	200	-	ms	-

Timing	Required By	Limits		Units	Notes
		Min	Max		
T ₁₀	Source	0	500	ms	-
T ₁₂	Source	1000	-	ms	

- Note)
1. Do not insert the mating cable when system turn on.
 2. Valid Data have to meet "3-3. Signal Timing Specifications"
 3. When the Video signal is invalid, be sure to pull down the power supply for LCD VLCD to 0V.
 4. The above power sequence should be satisfied the basic power on/off and resolution, timing transition.
 5. LED power must be turn on after power supply for LCD and valid status of Video Signal.
 6. Link training duration is dependent on the customer's system.

3-7-2. VLCD Power Dip Condition

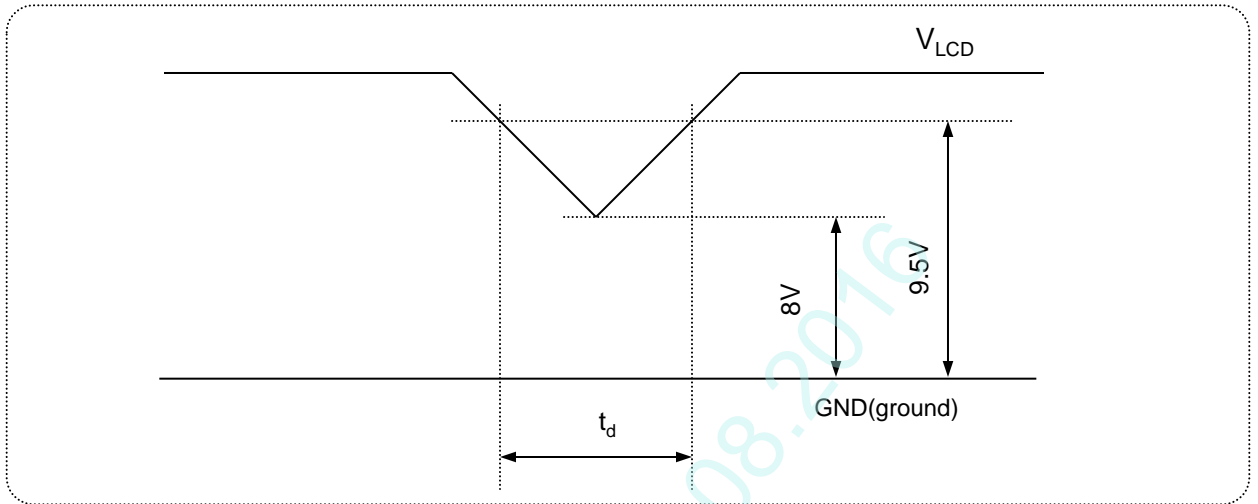

FIG.6 Power dip condition

1) Dip condition

$$8V \leq V_{LCD} < 9.5V, t_d \leq 20ms$$

2) $V_{LCD} < 8V$

V_{LCD} -dip conditions should also follow the Power On/Off conditions for supply voltage.

Product Specification

4. Optical Specifications

Optical characteristics are determined after the unit has been 'ON' for approximately 30 minutes in a dark environment at $25 \pm 2^\circ\text{C}$. The values specified are at an approximate distance 50cm from the LCD surface at a viewing angle of Φ and θ equal to 0° and aperture 1 degree.

FIG. 1 presents additional information concerning the measurement equipment and method.

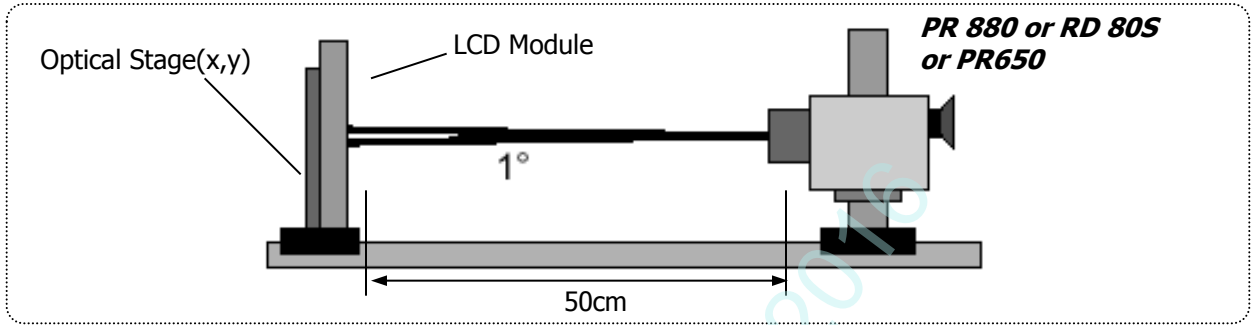

FIG.7 Optical Characteristic Measurement Equipment and Method

Table 9. OPTICAL CHARACTERISTICS

($T_a=25^\circ\text{C}$, $V_{LCD}=5\text{V}$, $f_v=60\text{Hz}$ Dclk=144MHz, $I_s=75\text{mA}$)

Parameter	Symbol	Values			Units	Notes	
		Min	Typ	Max			
Contrast Ratio	CR	-	1300	-		1	
Surface Luminance, white	L_{WH}	-	350	-	cd/m ²	2	
Luminance Variation	δ_{WHITE}	75	-	-	%	3	
Response Time	Gray To Gray	T_{GTG_AVR}	-	14	25	ms	4
Color Coordinates [CIE1931] (By PR650)	RED	Rx	Typ -0.03	0.652	Typ +0.03		
		Ry		0.338			
	GREEN	Gx		0.320			
		Gy		0.610			
	BLUE	Bx		0.150			
		By		0.063			
	WHITE	Wx		0.313			
	Wy	0.329					
Color Shift (Avg. $\Delta u'v' < 0.02$)	Horizontal	θ_{CST_H}	-	140	-	Degree	5
	Vertical	θ_{CST_V}	-	100	-		
Viewing Angle (CR>10)							
General	Horizontal	θ_H	170	178	-	Degree	6
	Vertical	θ_V	170	178	-		
GSR @ 60dgree (Gamma shift rate)	Horizontal	δ_{Gamma_H}	-	-	20	%	7
	Vertical	δ_{Gamma_V}	-	-	20		
WPT (White Point Tracking)	-	-	-300	G255 CCT	+700	K	8
Gray Scale	-	-	-	2.2	-		9

Product Specification

Notes 1. Contrast Ratio(CR) is defined mathematically as : **(By PR880)**

$$\text{Contrast Ratio} = \frac{\text{Surface Luminance with all white pixels}}{\text{Surface Luminance with all black pixels}}$$

It is measured at center point(Location P1)

2. Surface luminance(L_{WH})is luminance value at Center 1 point(P1) across the LCD surface 50cm from the surface with all pixels displaying white. For more information see FIG.8 (By PR880)

3. The variation in surface luminance , δ WHITE is defined as : **(By PR880)**

$$\delta_{\text{WHITE}} = \frac{\text{Minimum}(L_{P1}, L_{P2}, \dots, L_{P9})}{\text{Maximum}(L_{P1}, L_{P2}, \dots, L_{P9})} \times 100$$

Where L1 to L9 are the luminance with all pixels displaying white at 9 locations.
 For more information see FIG.8

4. Gray to gray response time is the time required for the display to transition from gray to gray.
 For additional information see Table 10. **(By RD80S)**

5. Color shift is the angle at which the average color difference for all Macbeth is lower than 0.02.
 For more information see FIG.9 **(By EZ Contrast)**
 - Color difference (Δu'v')

$$u' = \frac{4x}{-2x + 12y + 3} \quad v' = \frac{9y}{-2x + 12y + 3} \quad \Delta u'v' = \sqrt{(u'_1 - u'_2)^2 + (v'_1 - v'_2)^2}$$

$$\text{Avg}(\Delta u'v') = \frac{\sum_{i=1}^{24} (\Delta u'v')_i}{24}$$

u'1, v'1 : u'v' value at viewing angle direction
 u'2, v'2 : u'v' value at front (θ=0)
 i : Macbeth chart number (Define 23 page)

- Pattern size : 25% Box size
- Viewing angle direction of color shift : Horizontal, Vertical

6. Viewing angle is the angle at which the contrast ratio is greater than 10. The angles are determined for the horizontal or x axis and the vertical or y axis with respect to the z axis which is normal to the LCD surface. For more information see FIG.10 **(By PR880)**

7. GSR is the rate of gamma shift at up, down, left and right 60 degree viewing angle compare with center gamma. For more information see FIG.11 and FIG.12 **(By EZ Contrast)**
 - GSR (δ_{Gamma}) is defined as :

$$\text{GSR} = \left(1 - \frac{\text{View angle Gamma Value (Up, Down, Left, Right 60 Degree)}}{\text{Center Gamma Value (0 Degree)}} \right) \times 100$$

8. WPT (White Point Tracking) is the variation of color temperature between G255 and G63.
(By PR650)

Product Specification

Notes 9. Gamma Value is approximately 2.2. For more information see Table 11.

Measuring point for surface luminance & measuring point for luminance variation.

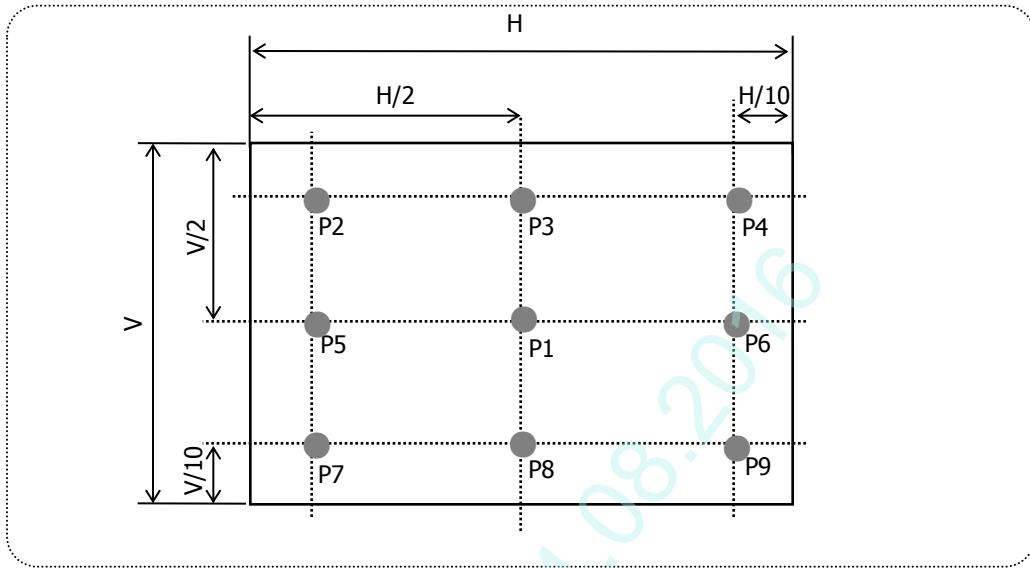

FIG.8 Measure Point for Luminance

The Gray to Gray response time is defined as the following figure and shall be measured by switching the input signal for "Gray To Gray".

- Gray step : 5 Step
- TGTG_AVR is the total average time at rising time and falling time for "Gray To Gray".
- if system use ODC (Over Driving Circuit) function, Gray to Gary response time may be 5ms~8ms GtG
- * it depends on Overshoot rate.

Table. 10 GTG Gray Table

Gray to Gray		Rising Time				
		G255	G191	G127	G63	G0
Falling Time	G255					
	G191					
	G127					
	G63					
	G0					

Product Specification

G to G(BW) Response time is defined as the following figure and shall be measured by switching the input signal for "Gray(N)" and "Black or White".

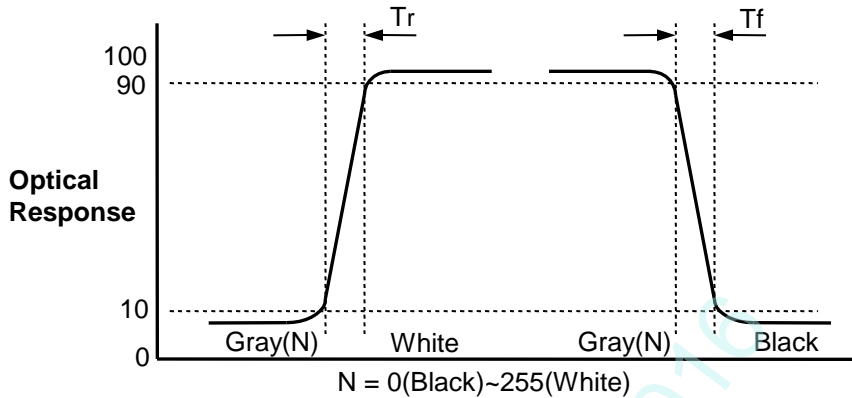

Color shift is defined as the following test pattern and color.

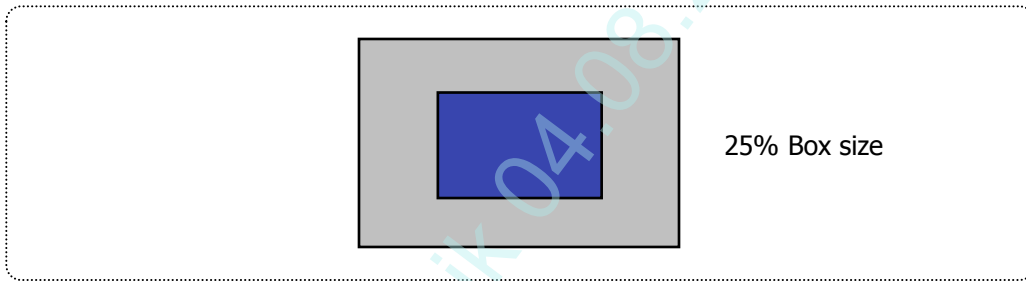

FIG.9 Color Shift Test Pattern

Average RGB values in Bruce RGB for Macbeth Chart

	Dark skin (i=1)	Light skin	Blue sky	Foliage	Blue flower	Bluish green
R	98	206	85	77	129	114
G	56	142	112	102	118	199
B	45	123	161	46	185	178
	Orange	Purplish blue	Moderate red	Purple	Yellow green	Orange yellow
R	219	56	211	76	160	230
G	104	69	67	39	193	162
B	24	174	87	86	58	29
	Blue	Green	Red	Yellow	Magenta	Cyan
R	26	72	197	241	207	35
G	32	148	27	212	62	126
B	145	65	37	36	151	172
	White	Neutral 8	Neutral 6.5	Neutral 5	Neutral 3.5	Black
R	240	206	155	110	63	22
G	240	206	155	110	63	22
B	240	206	155	110	63	22

Product Specification

Dimension of viewing angle range.

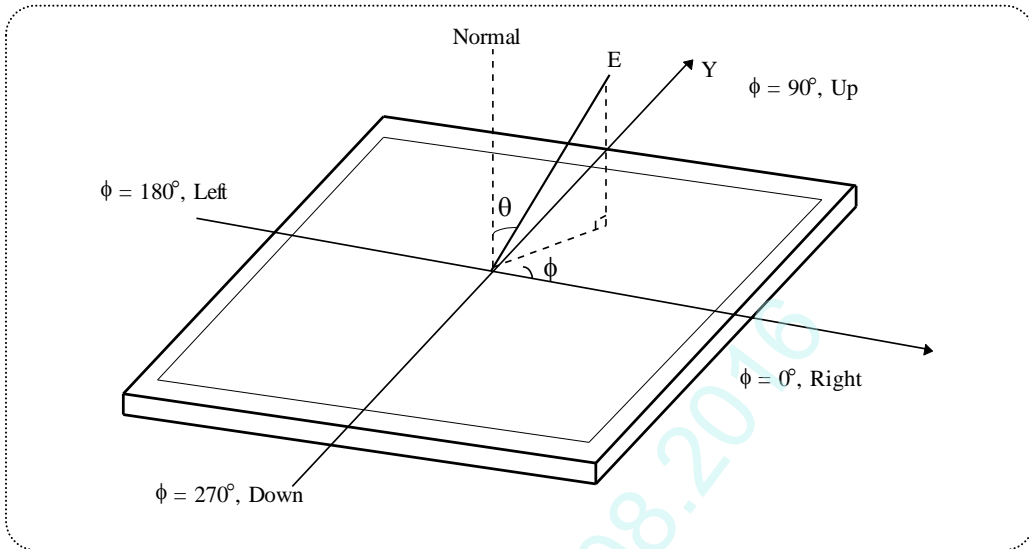

FIG.10 Viewing angle

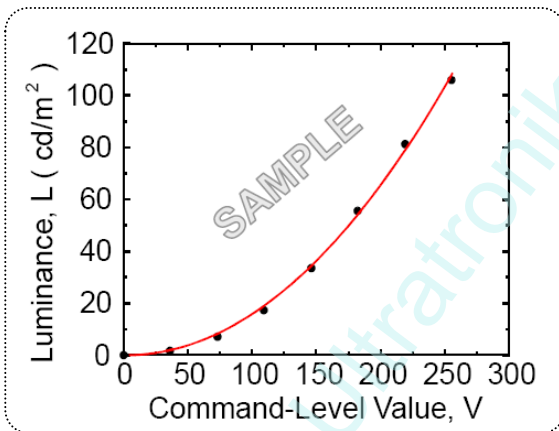

FIG.11 Sample Luminance vs. gray scale (using a 256 bit gray scale)

$$L = aV^r + L_b$$

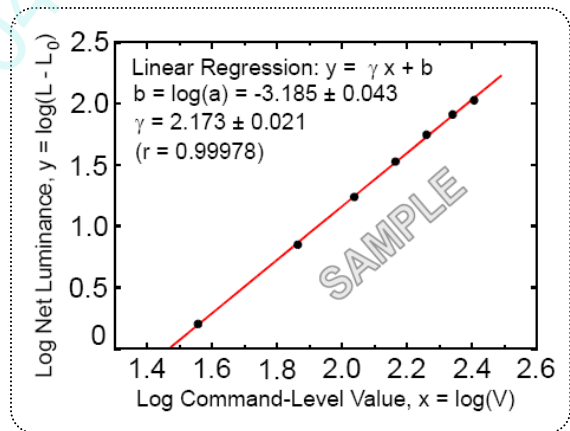

FIG.12 Sample Log-log plot of luminance vs. gray scale

$$\log(L - L_b) = r \log(V) + \log(a)$$

Here the Parameter a and γ relate the signal level V to the luminance L .
The GAMMA we calculate from the log-log representation (FIG.11)

Product Specification

Table 11. Gray Scale Specification

Gray Level	Relative Luminance [%] (Typ.)
0	0.11
31	1.08
63	4.72
95	11.49
127	21.66
159	35.45
191	53.00
223	74.48
255	100

Ultratronik 04.08.2016

Product Specification
5. Mechanical Characteristics

The contents provide general mechanical characteristics. In addition the figures in the next page are detailed mechanical drawing of the LCD.

Outline Dimension	Horizontal	709.2mm
	Vertical	405.1mm
	Depth	13.6 mm
Bezel Area	Horizontal	-
	Vertical	-
Active Display Area	Horizontal	697.31mm
	Vertical	392.23mm
Weight	Typ : TBD , Max : TBD	
Surface Treatment	Hard coating(3H) Anti-glare treatment of the front polarizer	

Notes : Please refer to a mechanic drawing in terms of tolerance at the next page.

Product Specification

<FRONT VIEW>

Preliminary

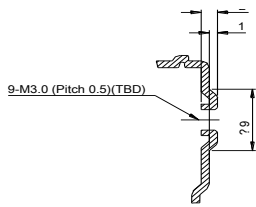
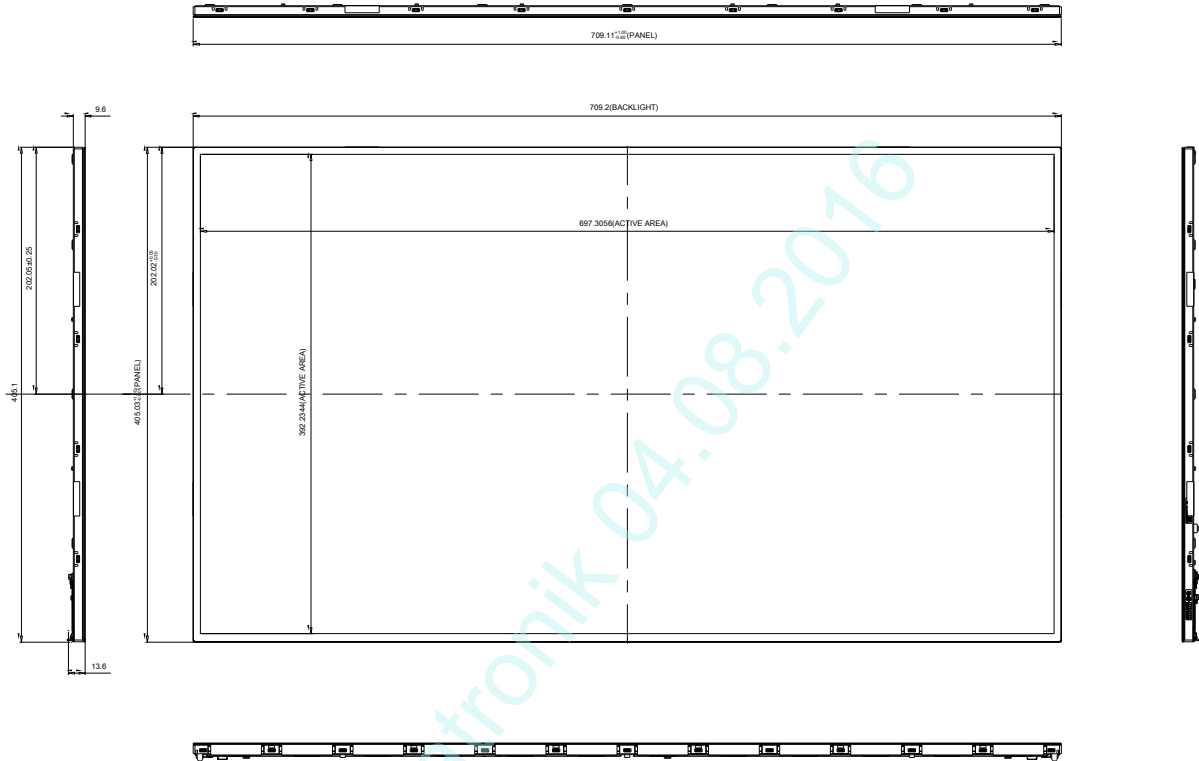

SECTION A-A
SCALE 2/1

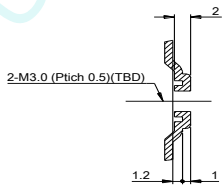

SECTION B-B
SCALE 2/1

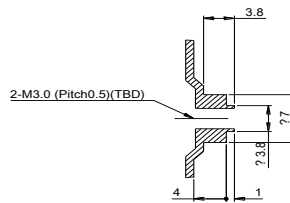

SECTION C-C
SCALE 2/1

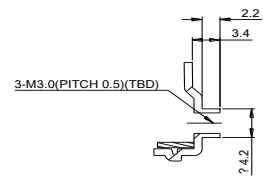

SECTION D-D
SCALE 2/1

Product Specification

<REAR VIEW>

Preliminary

* Reverse Panel

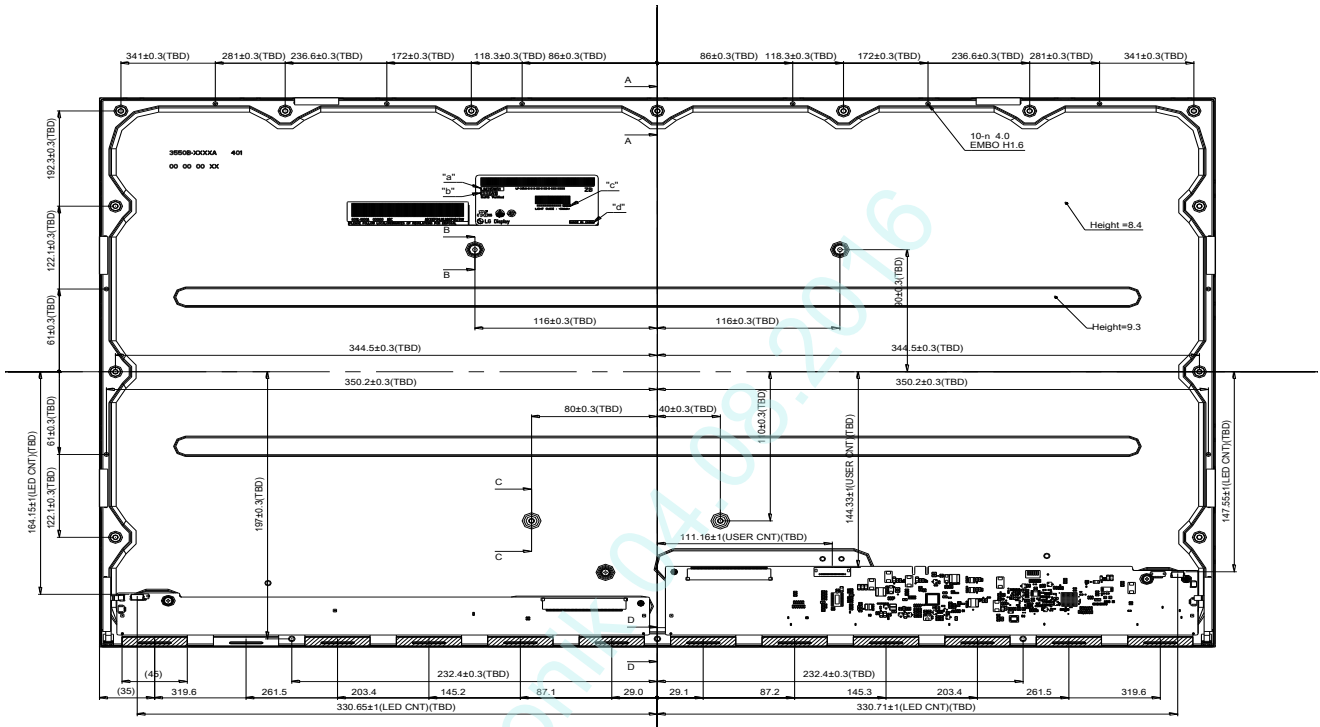

- Notes
1. I/F connector specification : LSMtron, GT050-30S-H10-MN or Equivalent.
 2. LED connector specification : SMO5B-SHJH (HF) (Manufactured by JST) or Equivalent
 3. Torque of user hole: 3.0~4.0kgf·cm
 4. Tilt and partial disposition tolerance of display area as following
 - (1) Y-direction
 - a. Upper side : -0.45C0.45, -0.45C0.45
 - b. Lower side : -0.45C0.6, -0.45C0.6
 - (2) X-direction : -0.45C0.45, -0.45C0.45

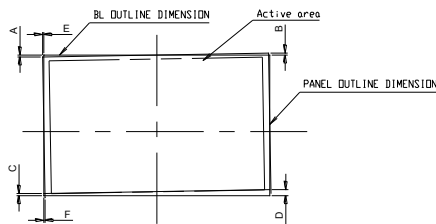

5. Unspecified tolerances to be ± 0.5
6. The LCM warp(warpage) is less than 1.0 on the surface plate
7. The CDF area is weak & sensitive, so please don't press the CDF area

LGD Highly recommendation :

As The IPS panel is sensitive & slim, please recommend the metal frame of the system supports the panel by the double side-mount.

Product Specification
6. Reliability

Environment test condition

No	Test Item	Condition
1	High temperature storage test	Ta= 60°C 240h
2	Low temperature storage test	Ta= -20°C 240h
3	High temperature operation test	Ta= 50°C 50%RH 240h
4	Low temperature operation test	Ta= 0°C 240h
5	Altitude operating storage / shipment	0 - 16,400 feet(5,000m) 0 - 40,000 feet(12,192m)

Note 1. Result Evaluation Criteria:

TFT-LCD panels test should take place after cooling enough at room temperature.

In the standard condition, there should be no particular problems that may affect the display function.

 ※. T_a= Ambient Temperature

7. International Standards

7-1. Safety

- a) UL 60950-1, Underwriters Laboratories Inc.
Information Technology Equipment - Safety - Part 1 : General Requirements.
- b) CAN/CSA-C22.2 No. 60950-1-07, Canadian Standards Association.
Information Technology Equipment - Safety - Part 1 : General Requirements.
- c) EN 60950-1, European Committee for Electrotechnical Standardization (CENELEC).
Information Technology Equipment - Safety - Part 1 : General Requirements.
- d) IEC 60950-1, The International Electrotechnical Commission (IEC).
Information Technology Equipment - Safety - Part 1 : General Requirements

7-2. EMC

- a) ANSI C63.4 "American National Standard for Methods of Measurement of Radio-Noise Emissions from Low-Voltage Electrical and Electronic Equipment in the Range of 9 kHz to 40 GHz." American National Standards Institute (ANSI), 2003.
- b) CISPR 22 "Information technology equipment – Radio disturbance characteristics – Limit and methods of measurement." International Special Committee on Radio Interference (CISPR), 2005.
- c) CISPR 13 "Sound and television broadcast receivers and associated equipment – Radio disturbance characteristics – Limits and method of measurement." International Special Committee on Radio Interference (CISPR), 2006.

7-3. Environment

- a) RoHS, Directive 2011/65/EU of the European Parliament and of the council of 8 June 2011

Product Specification

8. Packing

8-1. Designation of Lot Mark

a) Lot Mark

A	B	C	D	E	F	G	H	I	J	K	L	M
---	---	---	---	---	---	---	---	---	---	---	---	---

A,B,C : SIZE(INCH)

E : MONTH

D : YEAR

F ~ M : SERIAL NO.

Note

1. YEAR

Year	2011	2012	2013	2014	2015	2016	2017	2018	2019	2020
Mark	A	B	C	D	E	F	G	H	J	K

2. MONTH

Month	Jan	Feb	Mar	Apr	May	Jun	Jul	Aug	Sep	Oct	Nov	Dec
Mark	1	2	3	4	5	6	7	8	9	A	B	C

b) Location of Lot Mark

Serial No. is printed on the label. The label is attached to the backside of the LCD module.
This is subject to change without prior notice.

8-2. Packing Form

- a) Package quantity in one box : 12 pcs (1 Module is packed in 1 Al Bag)
- b) Box quantity in one pallet : 12 boxes
- c) Box Size : 635 X 370 X 400

Product Specification

9. PRECAUTIONS

Please pay attention to the followings when you use this TFT LCD module.

9-1. MOUNTING PRECAUTIONS

- (1) You must mount a module using holes arranged in four corners or four sides.
- (2) You should consider the mounting structure so that uneven force (ex. Twisted stress) is not applied to the module. And the case on which a module is mounted should have sufficient strength so that external force is not transmitted directly to the module.
- (3) Please attach the surface transparent protective plate to the surface in order to protect the polarizer. Transparent protective plate should have sufficient strength in order to resist external force.
- (4) You should adopt radiation structure to satisfy the temperature specification.
- (5) Acetic acid type and chlorine type materials for the cover case are not desirable because the former generates corrosive gas of attacking the polarizer at high temperature and the latter causes circuit break by electro-chemical reaction.
- (6) Do not touch, push or rub the exposed polarizers with glass, tweezers or anything harder than HB pencil lead. And please do not rub with dust clothes with chemical treatment. Do not touch the surface of polarizer for bare hand or greasy cloth. (Some cosmetics are detrimental to the polarizer.)
- (7) When the surface becomes dusty, please wipe gently with absorbent cotton or other soft materials like chamois soaks with petroleum benzene. Normal-hexane is recommended for cleaning the adhesives used to attach front / rear polarizers. Do not use acetone, toluene and alcohol because they cause chemical damage to the polarizer.
- (8) Wipe off saliva or water drops as soon as possible. Their long time contact with polarizer causes deformations and color fading.
- (9) Do not open the case because inside circuits do not have sufficient strength.
- (10) As The IPS panel is sensitive & slim, please recommend the metal frame of the system supports the panel by the double side-mount.

9-2. OPERATING PRECAUTIONS

- (1) The spike noise causes the mis-operation of circuits. It should be lower than following voltage :
 $V = \pm 200\text{mV}$ (Over and under shoot voltage)
- (2) Response time depends on the temperature. (In lower temperature, it becomes longer.)
- (3) Brightness depends on the temperature. (In Higher temperature, it becomes lower.)
 And in lower temperature, response time (required time that brightness is stable after turned on) becomes longer.
- (4) Be careful for condensation at sudden temperature change. Condensation makes damage to polarizer or electrical contacted parts. And after fading condensation, smear or spot will occur.
- (5) When fixed patterns are displayed for a long time, remnant image is likely to occur.
- (6) Module has high frequency circuits. Sufficient suppression to the electromagnetic interference shall be done by system manufacturers. Grounding and shielding methods may be important to minimized the interference.
- (7) Please do not give any mechanical and/or acoustical impact to LCM. Otherwise, LCM can't be operated its full characteristics perfectly.
- (8) A screw which is fastened up the steels should be a machine screw.
 (if not, it causes metallic foreign material and deal LCM a fatal blow)
- (9) Please do not set LCD on its edge.
- (10) When LCMs are used for public display defects such as Yogore, image sticking can not be guaranteed.
- (11) LCMs cannot support "Interlaced Scan Method"
- (12) When this reverse model is used as a forward-type model (PCB on top side), LGD can not guarantee any defects of LCM.
- (13) Please conduct image sticking test after 2-hour aging with Rolling Pattern and normal temperature. (25~40°C)

Product Specification

9-3. ELECTROSTATIC DISCHARGE CONTROL

Since a module is composed of electronic circuits, it is not strong to electrostatic discharge. Make certain that treatment persons are connected to ground through wrist band etc. And don't touch interface pin directly.

9-4. PRECAUTIONS FOR STRONG LIGHT EXPOSURE

Strong light exposure causes degradation of polarizer and color filter.

9-5. STORAGE

When storing modules as spares for a long time, the following precautions are necessary.

- (1) Store them in a dark place. Do not expose the module to sunlight or fluorescent light. Keep the temperature between 5°C and 35°C at normal humidity.
- (2) The polarizer surface should not come in contact with any other object.
It is recommended that they be stored in the container in which they were shipped.

9-6. HANDLING PRECAUTIONS FOR PROTECTION FILM

- (1) The protection film is attached to the bezel with a small masking tape.
When the protection film is peeled off, static electricity is generated between the film and polarizer.
This should be peeled off slowly and carefully by people who are electrically grounded and with well ion-blown equipment or in such a condition, etc.
- (2) When the module with protection film attached is stored for a long time, sometimes there remains a very small amount of glue still on the bezel after the protection film is peeled off.
- (3) You can remove the glue easily. When the glue remains on the bezel surface or its vestige is recognized, please wipe them off with absorbent cotton waste or other soft material like chamois soaked with normal-hexane.