

LM317M, LM317MA

Three-Terminal Adjustable Output Positive Voltage Regulator

The LM317M is an adjustable three-terminal positive voltage regulator capable of supplying in excess of 500 mA over an output voltage range of 1.2 V to 37 V. This voltage regulator is exceptionally easy to use and requires only two external resistors to set the output voltage. Further, it employs internal current limiting, thermal shutdown and safe area compensation, making it essentially blow-out proof.

The LM317M serves a wide variety of applications including local, on-card regulation. This device also makes an especially simple adjustable switching regulator, a programmable output regulator, or by connecting a fixed resistor between the adjustment and output, the LM317M can be used as a precision current regulator.

- Output Current in Excess of 500 mA
- Output Adjustable between 1.2 V and 37 V
- Internal Thermal Overload Protection
- Internal Short Circuit Current Limiting
- Output Transistor Safe-Area Compensation
- Floating Operation for High Voltage Applications
- Eliminates Stocking Many Fixed Voltages

Simplified Application

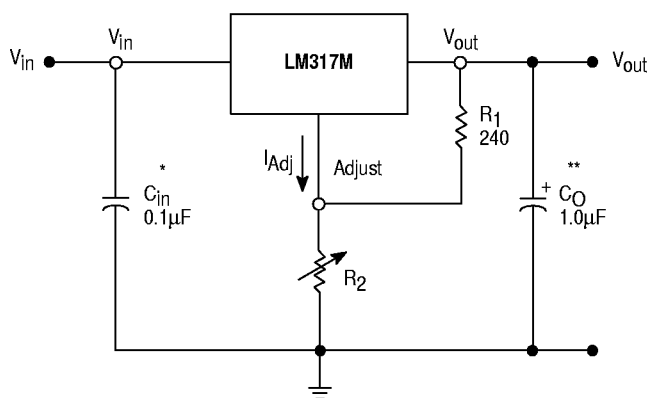

* = C_{in} is required if regulator is located an appreciable distance from power supply filter.
 ** = C_O is not needed for stability, however, it does improve transient response.

$$V_{out} = 1.25 V \left(1 + \frac{R_2}{R_1} \right) + I_{Adj} R_2$$

Since I_{Adj} is controlled to less than 100 μA , the error associated with this term is negligible in most applications.

MEDIUM CURRENT THREE-TERMINAL ADJUSTABLE POSITIVE VOLTAGE REGULATOR SEMICONDUCTOR TECHNICAL DATA

T SUFFIX
PLASTIC PACKAGE
CASE 221A

Heatsink surface
connected to Pin 2

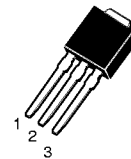
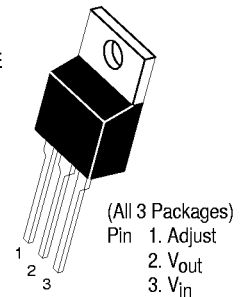

DT-1 SUFFIX
PLASTIC PACKAGE
CASE 369
(DPAK)

DT SUFFIX
PLASTIC PACKAGE
CASE 369A
(DPAK)

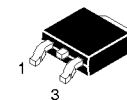

Heatsink Surface (shown as terminal 4 in case outline drawing) is connected to Pin 2.

ORDERING INFORMATION

Device	Operating Temperature Range	Package
LM317MT LM317MAT	$T_J = 0^\circ \text{ to } +125^\circ \text{C}$	Plastic Power
LM317MBT# LM317MABT#	$T_J = -40^\circ \text{ to } +125^\circ \text{C}$	Plastic Power
LM317MDT LM317MADT LM317MDT-1 LM317MADT-1	$T_J = 0^\circ \text{ to } 125^\circ \text{C}$	DPAK
LM317MBDT LM317MABDT LM317MBDT-1 LM317MABDT-1	$T_J = -40^\circ \text{ to } 125^\circ \text{C}$	DPAK

Automotive temperature range selections are available with special test conditions and additional tests. Contact your local Motorola sales office for information.

LM317M, LM317MA

MAXIMUM RATINGS ($T_A = 25^\circ\text{C}$, unless otherwise noted.)

Rating	Symbol	Value	Unit
Input–Output Voltage Differential	$V_I - V_O$	40	Vdc
Power Dissipation (Package Limitation) (Note 1) Plastic Package, T Suffix $T_A = 25^\circ\text{C}$ Thermal Resistance, Junction–to–Air Thermal Resistance, Junction–to–Case	P_D θ_{JA} θ_{JC}	Internally Limited 70 5.0	$^\circ\text{C/W}$ $^\circ\text{C/W}$
Plastic Package, DT Suffix $T_A = 25^\circ\text{C}$ Thermal Resistance, Junction–to–Air Thermal Resistance, Junction–to–Case	P_D θ_{JA} θ_{JC}	Internally Limited 92 5.0	$^\circ\text{C/W}$ $^\circ\text{C/W}$
Operating Junction Temperature Range	T_J	–40 to +125	$^\circ\text{C}$
Storage Temperature Range	T_{stg}	–65 to +150	$^\circ\text{C}$

NOTE: 1. Figure 23 provides thermal resistance versus pc board pad size.

ELECTRICAL CHARACTERISTICS ($V_I - V_O = 5.0\text{ V}$; $I_O = 0.1\text{ A}$, $T_J = T_{low}$ to T_{high} [Note 1], unless otherwise noted.)

Characteristics	Figure	Symbol	Min	Typ	Max	Unit
Line Regulation (Note 2) $T_A = 25^\circ\text{C}$, $3.0\text{ V} \leq V_I - V_O \leq 40\text{ V}$	1	Reg _{line}	–	0.01	0.04	%/V
Load Regulation (Note 2) $T_A = 25^\circ\text{C}$, $10\text{ mA} \leq I_O \leq 0.5\text{ A}$ $V_O \leq 5.0\text{ V}$ $V_O \geq 5.0\text{ V}$	2	Reg _{load}	– –	5.0 0.1	25 0.5	mV % V_O
Adjustment Pin Current	3	I_{Adj}	–	50	100	μA
Adjustment Pin Current Change $2.5\text{ V} \leq V_I - V_O \leq 40\text{ V}$, $10\text{ mA} \leq I_L \leq 0.5\text{ A}$, $P_D \leq P_{max}$	1,2	ΔI_{Adj}	–	0.2	5.0	μA
Reference Voltage $3.0\text{ V} \leq V_I - V_O \leq 40\text{ V}$, $10\text{ mA} \leq I_O \leq 0.5\text{ A}$, $P_D \leq P_{max}$	LM317M: LM317MA: 3	V_{ref}	1.200 1.225	1.250 1.250	1.300 1.275	V
Line Regulation (Note 2) $3.0\text{ V} \leq V_I - V_O \leq 40\text{ V}$	1	Reg _{line}	–	0.02	0.07	%/V
Load Regulation (Note 2) $10\text{ mA} \leq I_O \leq 0.5\text{ A}$ $V_O \leq 5.0\text{ V}$ $V_O \geq 5.0\text{ V}$	2	Reg _{load}	– –	20 0.3	70 1.5	mV % V_O
Temperature Stability ($T_{low} \leq T_J \leq T_{high}$)	3	T_S	–	0.7	–	% V_O
Minimum Load Current to Maintain Regulation ($V_I - V_O = 40\text{ V}$)	3	I_{Lmin}	–	3.5	10	mA
Maximum Output Current $V_I - V_O \leq 15\text{ V}$, $P_D \leq P_{max}$ $V_I - V_O = 40\text{ V}$, $P_D \leq P_{max}$, $T_A = 25^\circ\text{C}$	3	I_{max}	0.5 0.15	0.9 0.25	– –	A
RMS Noise, % of V_O $T_A = 25^\circ\text{C}$, $10\text{ Hz} \leq f \leq 10\text{ kHz}$	–	N	–	0.003	–	% V_O
Ripple Rejection, $V_O = 10\text{ V}$, $f = 120\text{ Hz}$ (Note 3) Without C_{Adj} $C_{Adj} = 10\text{ }\mu\text{F}$	4	RR	– 66	65 80	– –	dB
Long–Term Stability, $T_J = T_{high}$ (Note 4) $T_A = 25^\circ\text{C}$ for Endpoint Measurements	3	S	–	0.3	1.0	%/1.0 k Hrs.

- NOTES:** 1. T_{low} to $T_{high} = 0^\circ$ to $+125^\circ\text{C}$ for LM317M T_{low} to $T_{high} = -40^\circ$ to $+125^\circ\text{C}$ for LM317MB
2. Load and line regulation are specified at constant junction temperature. Changes in V_O due to heating effects must be taken into account separately. Pulse testing with low duty cycle is used.
3. C_{Adj} , when used, is connected between the adjustment pin and ground.
4. Since Long–Term Stability cannot be measured on each device before shipment, this specification is an engineering estimate of average stability from lot to lot.

LM317M, LM317MA

Representative Schematic Diagram

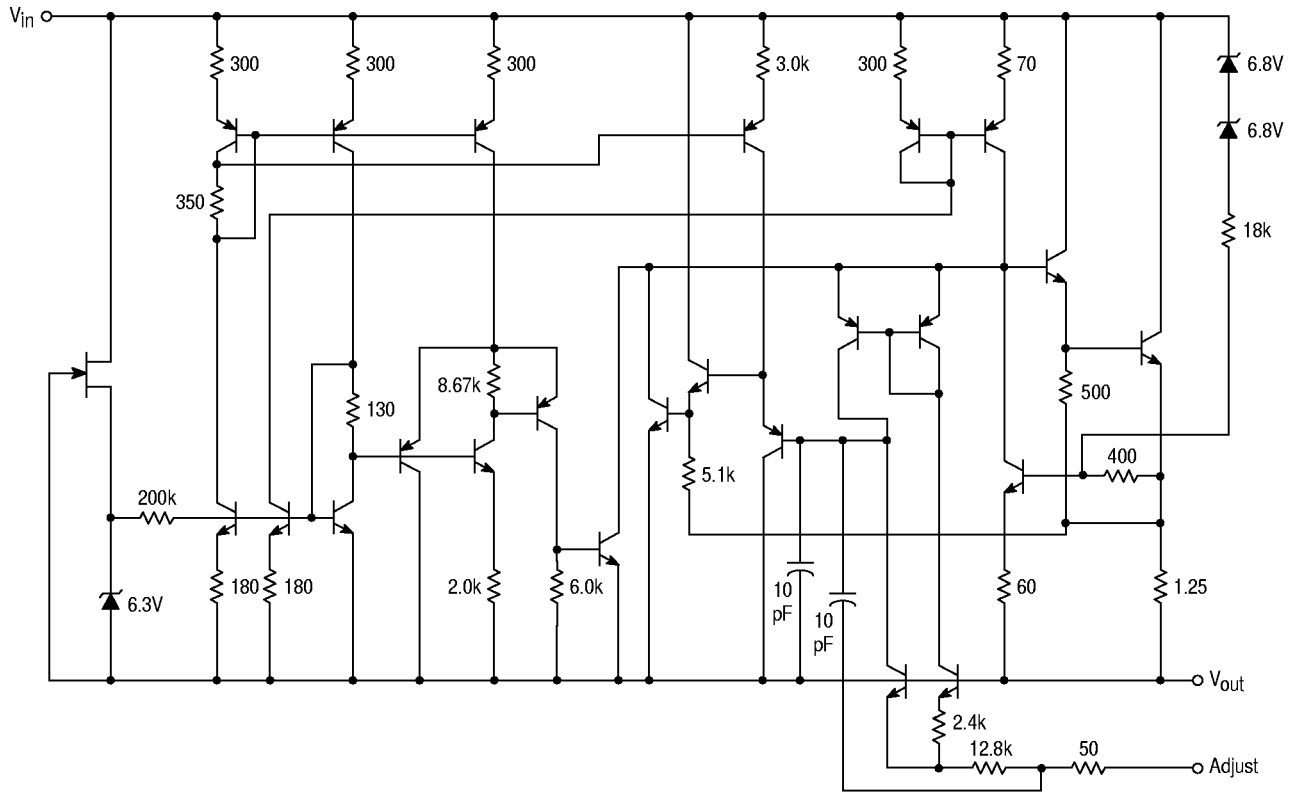
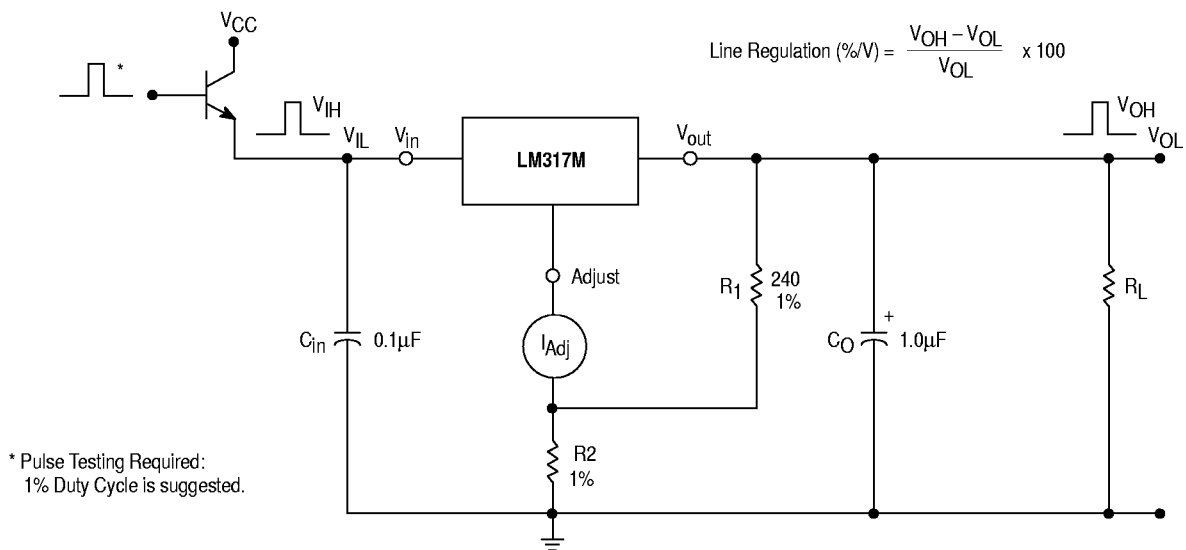

Figure 1. Line Regulation and ΔI_{Adj} /Line Test Circuit



LM317M, LM317MA

Figure 2. Load Regulation and ΔI_{Adj} /Load Test Circuit

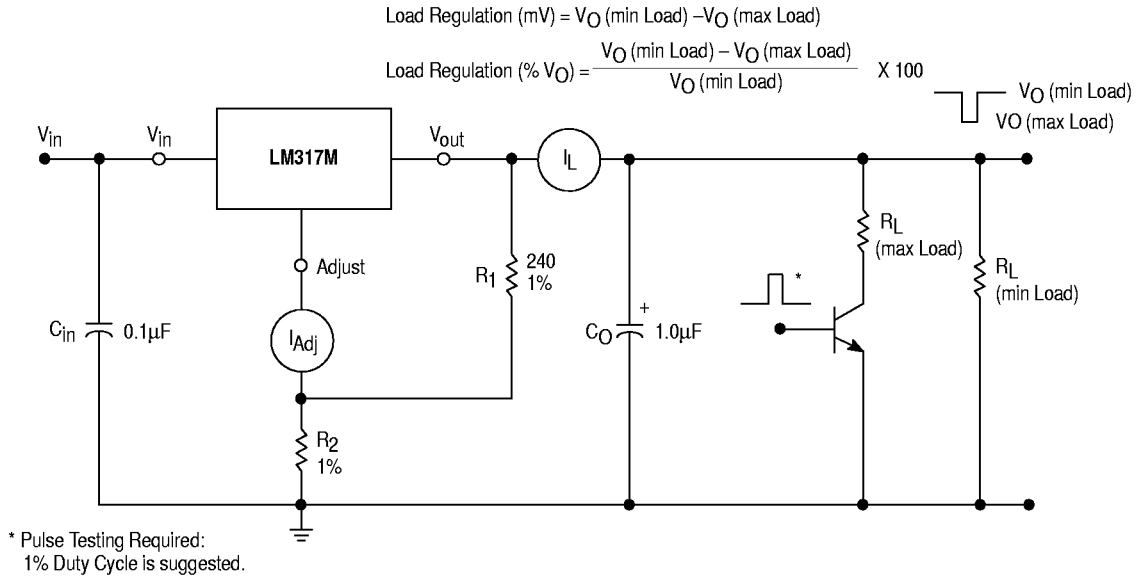

Figure 3. Standard Test Circuit

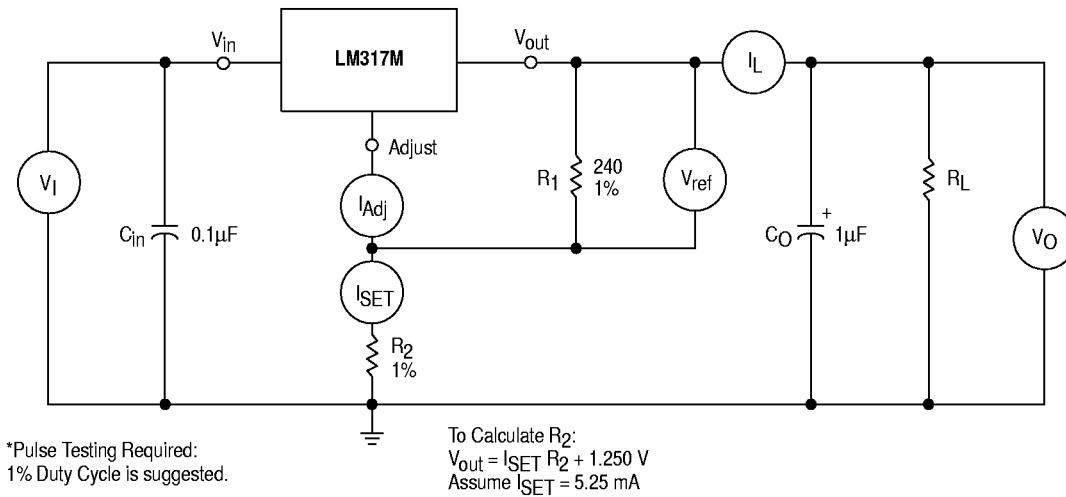
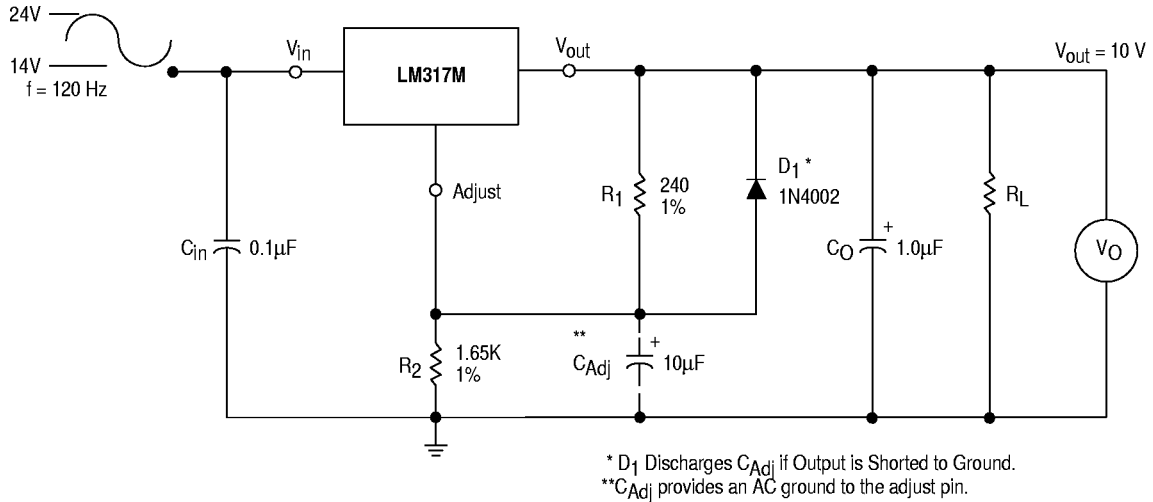

Figure 4. Ripple Rejection Test Circuit



LM317M, LM317MA

Figure 5. Load Regulation

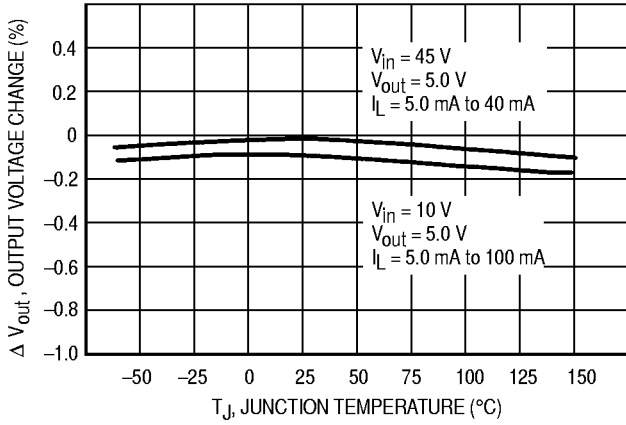

Figure 6. Ripple Rejection

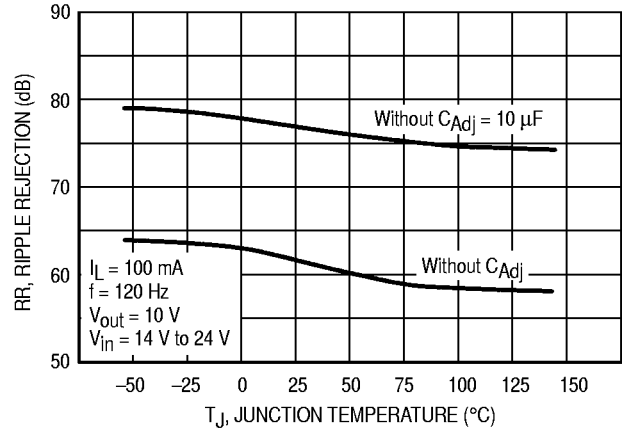

Figure 7. Current Limit

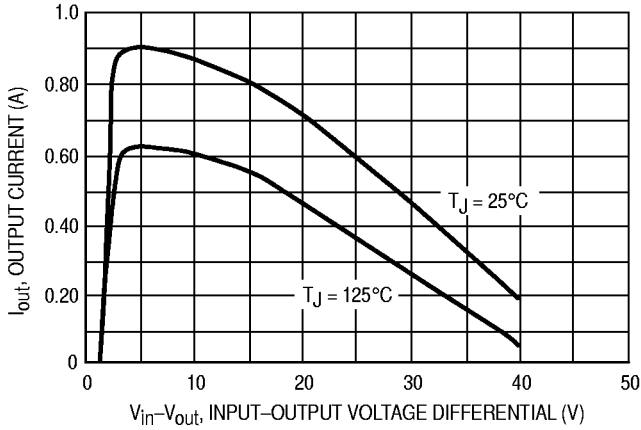

Figure 8. Dropout Voltage

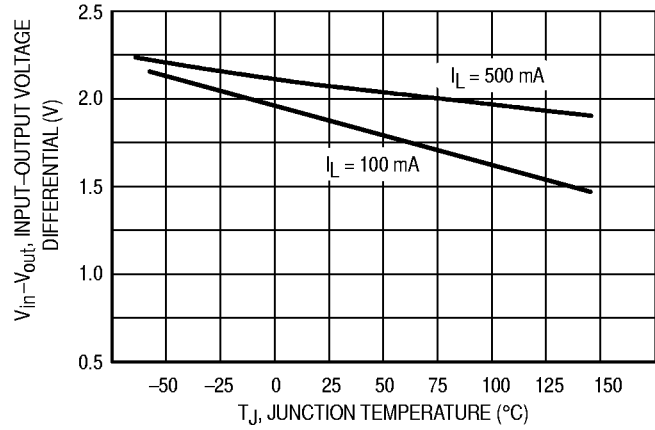

Figure 9. Minimum Operating Current

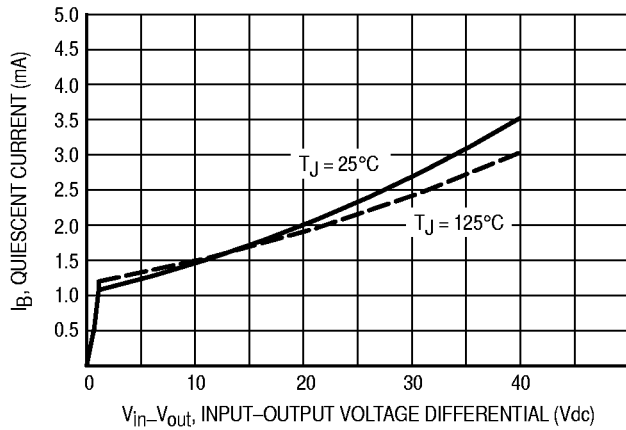
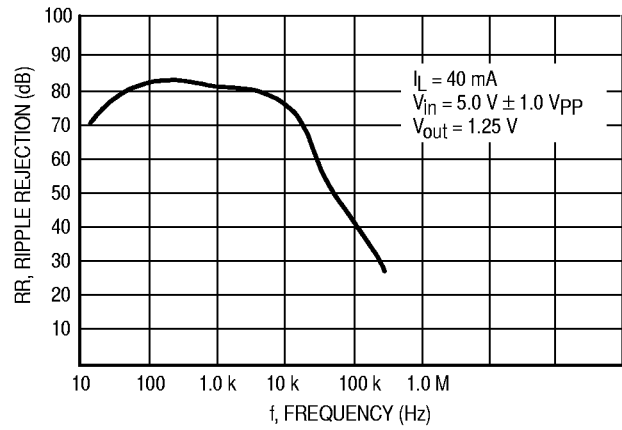

Figure 10. Ripple Rejection versus Frequency



LM317M, LM317MA

Figure 11. Temperature Stability

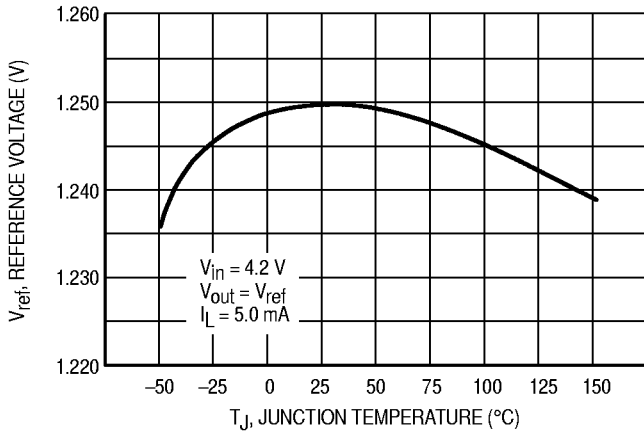

Figure 12. Adjustment Pin Current

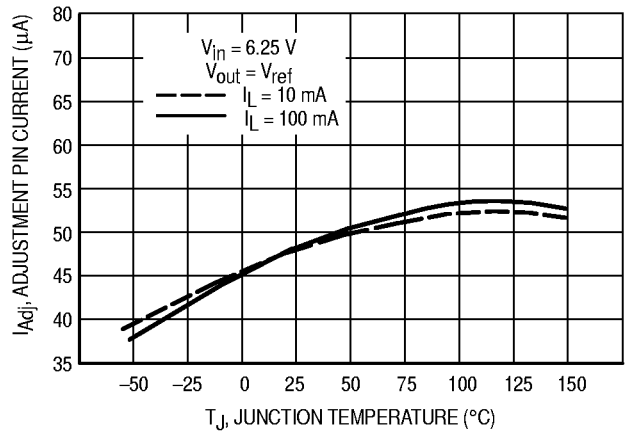

Figure 13. Line Regulation

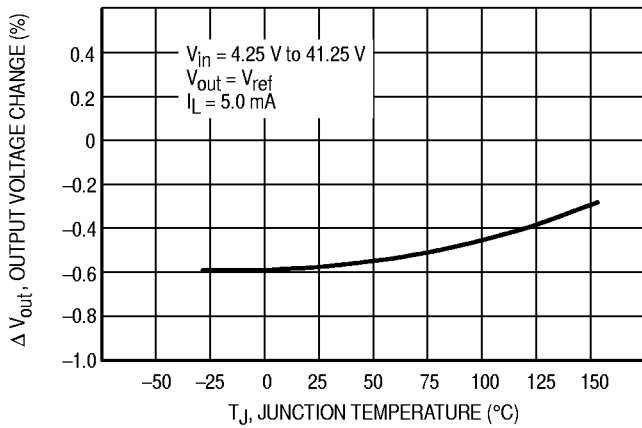

Figure 14. Output Noise

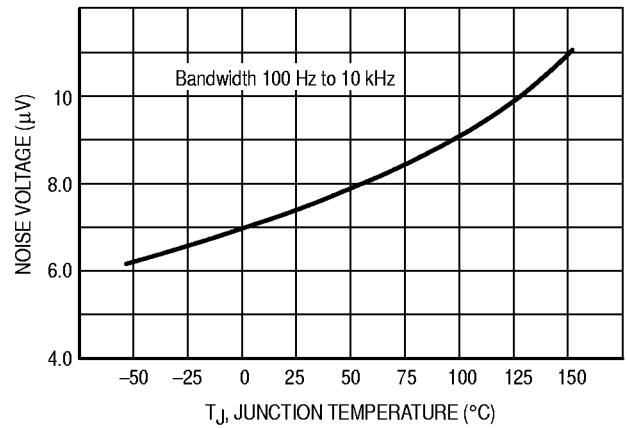

Figure 15. Line Transient Response

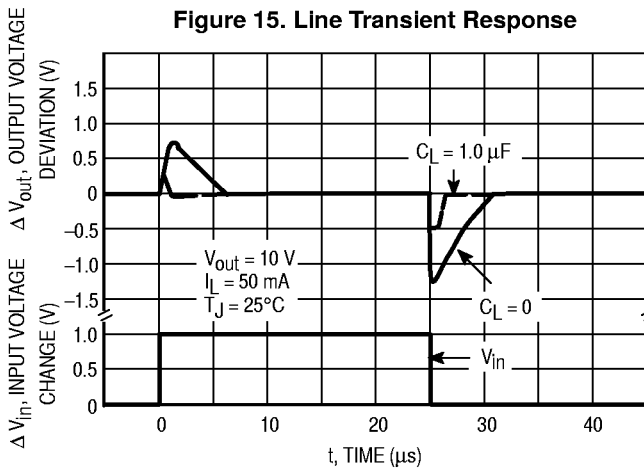
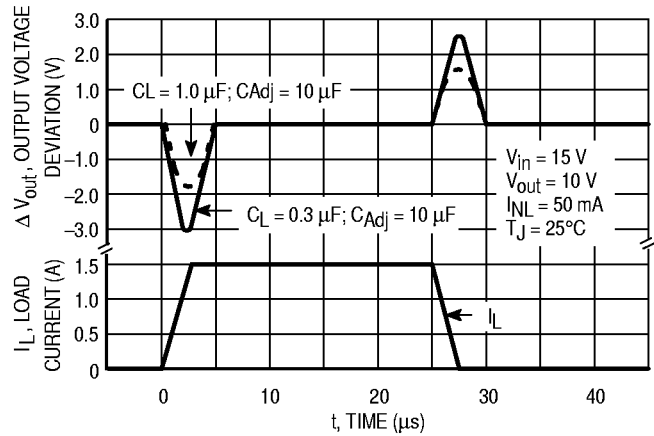

Figure 16. Load Transient Response



LM317M, LM317MA

APPLICATIONS INFORMATION

Basic Circuit Operation

The LM317M is a three-terminal floating regulator. In operation, the LM317M develops and maintains a nominal 1.25 V reference (V_{ref}) between its output and adjustment terminals. This reference voltage is converted to a programming current (I_{PROG}) by R_1 (see Figure 17), and this constant current flows through R_2 to ground. The regulated output voltage is given by:

$$V_{out} = V_{ref} \left(1 + \frac{R_2}{R_1} \right) + I_{Adj} R_2$$

Since the current from the terminal (I_{Adj}) represents an error term in the equation, the LM317M was designed to control I_{Adj} to less than 100 μA and keep it constant. To do this, all quiescent operating current is returned to the output terminal. This imposes the requirement for a minimum load current. If the load current is less than this minimum, the output voltage will rise.

Since the LM317M is a floating regulator, it is only the voltage differential across the circuit which is important to performance, and operation at high voltages with respect to ground is possible.

Figure 17. Basic Circuit Configuration

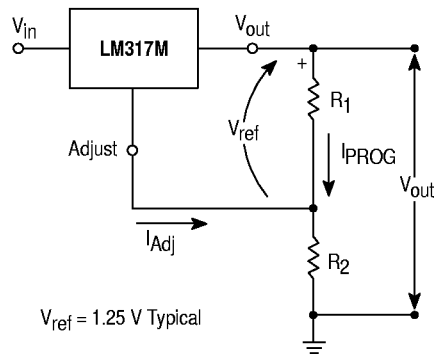

Load Regulation

The LM317M is capable of providing extremely good load regulation, but a few precautions are needed to obtain maximum performance. For best performance, the programming resistor (R_1) should be connected as close to the regulator as possible to minimize line drops which effectively appear in series with the reference, thereby degrading regulation. The ground end of R_2 can be returned near the load ground to provide remote ground sensing and improve load regulation.

External Capacitors

A 0.1 μF disc or 1.0 μF tantalum input bypass capacitor (C_{in}) is recommended to reduce the sensitivity to input line impedance.

The adjustment terminal may be bypassed to ground to improve ripple rejection. This capacitor (C_{Adj}) prevents ripple from being amplified as the output voltage is increased. A 10 μF capacitor should improve ripple rejection about 15 dB at 120 Hz in a 10 V application.

Although the LM317M is stable with no output capacitance, like any feedback circuit, certain values of external capacitance can cause excessive ringing. An output capacitance (C_O) in the form of a 1.0 μF tantalum or 25 μF aluminum electrolytic capacitor on the output swamps this effect and insures stability.

Protection Diodes

When external capacitors are used with any IC regulator it is sometimes necessary to add protection diodes to prevent the capacitors from discharging through low current points into the regulator.

Figure 18 shows the LM317M with the recommended protection diodes for output voltages in excess of 25 V or high capacitance values ($C_O > 25 \mu F$, $C_{Adj} > 5.0 \mu F$). Diode D_1 prevents C_O from discharging thru the IC during an input short circuit. Diode D_2 protects against capacitor C_{Adj} discharging through the IC during an output short circuit. The combination of diodes D_1 and D_2 prevents C_{Adj} from discharging through the IC during an input short circuit.

Figure 18. Voltage Regulator with Protection Diodes

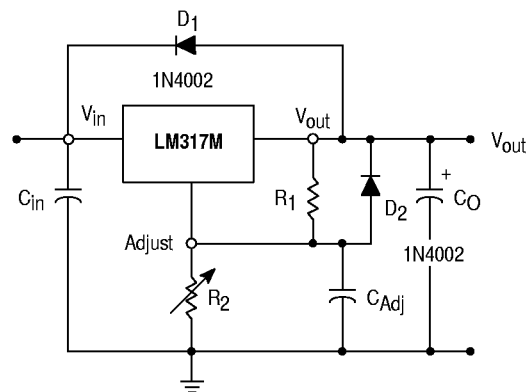

LM317M, LM317MA

Figure 19. Adjustable Current Limiter

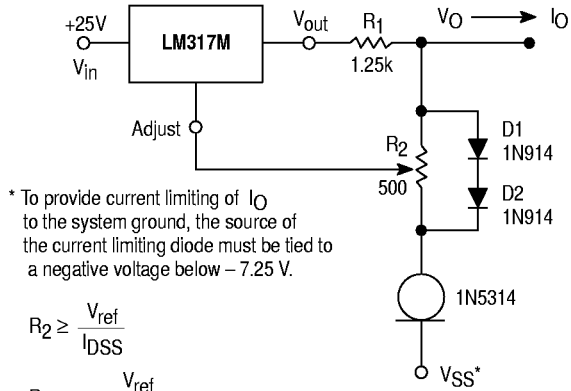

* To provide current limiting of I_O to the system ground, the source of the current limiting diode must be tied to a negative voltage below -7.25 V.

$$R_2 \geq \frac{V_{ref}}{I_{DSS}}$$

$$R_1 = \frac{V_{ref}}{I_{Omax} + I_{DSS}}$$

$V_O < P_{OV} + 1.25$ V + V_{SS}
 $I_{Lmin} - I_P < I_O < 500$ mA - I_P
 As shown $0 < I_O < 495$ mA

Figure 20. 5 V Electronic Shutdown Regulator

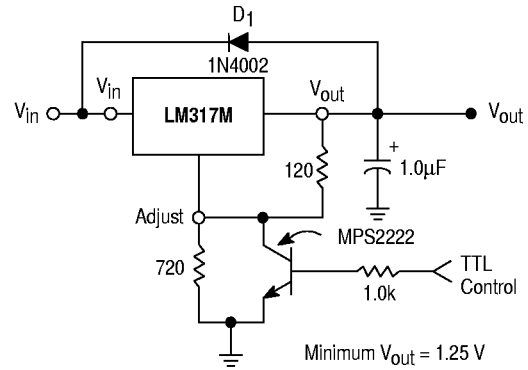

D1 protects the device during an input short circuit.

Figure 21. Slow Turn-On Regulator

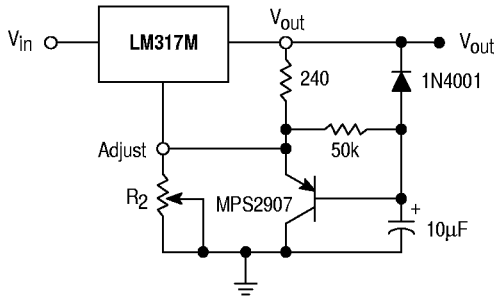
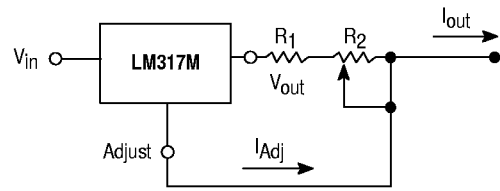

Figure 22. Current Regulator



$$I_{outmax} = \left(\frac{V_{ref}}{R_1 + R_2} \right) + I_{Adj} \approx \frac{1.25}{R_1 + R_2}$$

5.0 mA < I_{out} < 100 mA

Figure 23. DPAK Thermal Resistance and Maximum Power Dissipation versus P.C.B. Copper Length

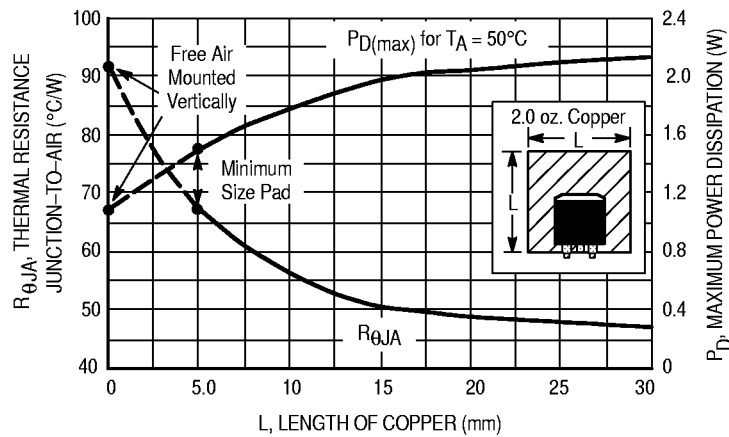

LM317M, LM317MA

OUTLINE DIMENSIONS

T SUFFIX PLASTIC PACKAGE CASE 221A-06 ISSUE Y

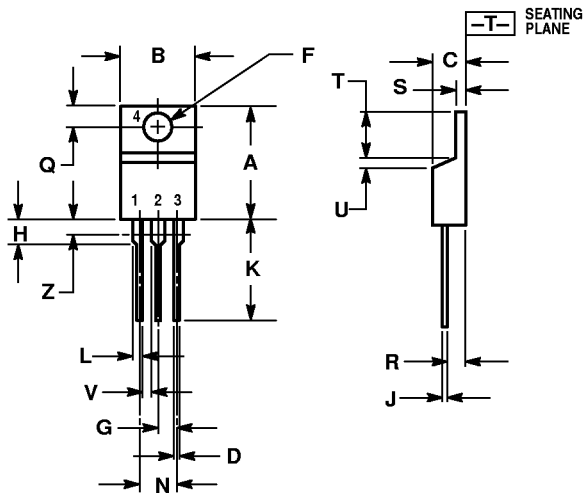

- NOTES:
1. DIMENSIONING AND TOLERANCING PER ANSI Y14.5M, 1982.
 2. CONTROLLING DIMENSION: INCH.
 3. DIMENSION Z DEFINES A ZONE WHERE ALL BODY AND LEAD IRREGULARITIES ARE ALLOWED.

DIM	INCHES		MILLIMETERS	
	MIN	MAX	MIN	MAX
A	0.570	0.620	14.48	15.75
B	0.380	0.405	9.66	10.28
C	0.160	0.190	4.07	4.82
D	0.025	0.035	0.64	0.88
F	0.142	0.147	3.61	3.73
G	0.095	0.105	2.42	2.66
H	0.110	0.155	2.80	3.93
J	0.018	0.025	0.46	0.64
K	0.500	0.562	12.70	14.27
L	0.045	0.060	1.15	1.52
N	0.190	0.210	4.83	5.33
Q	0.100	0.120	2.54	3.04
R	0.080	0.110	2.04	2.79
S	0.045	0.055	1.15	1.39
T	0.235	0.255	5.97	6.47
U	0.000	0.050	0.00	1.27
V	0.045	—	1.15	—
Z	—	0.080	—	2.04

DT-1 SUFFIX PLASTIC PACKAGE CASE 369-07 (DPAK) ISSUE K

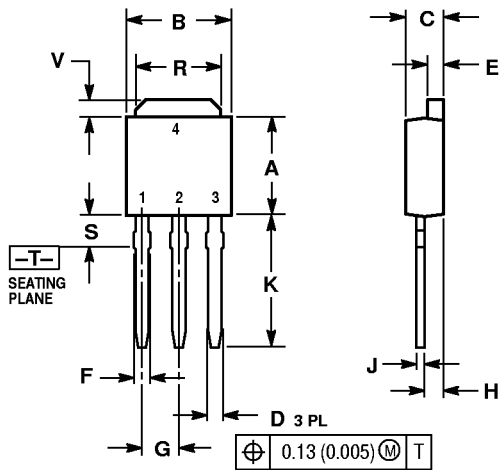

- NOTES:
1. DIMENSIONING AND TOLERANCING PER ANSI Y14.5M, 1982.
 2. CONTROLLING DIMENSION: INCH.

DIM	INCHES		MILLIMETERS	
	MIN	MAX	MIN	MAX
A	0.235	0.250	5.97	6.35
B	0.250	0.265	6.35	6.73
C	0.086	0.094	2.19	2.38
D	0.027	0.035	0.69	0.88
E	0.033	0.040	0.84	1.01
F	0.037	0.047	0.94	1.19
G	0.090	BSC	2.29	BSC
H	0.034	0.040	0.87	1.01
J	0.018	0.023	0.46	0.58
K	0.350	0.380	8.89	9.65
R	0.175	0.215	4.45	5.46
S	0.050	0.090	1.27	2.28
V	0.030	0.050	0.77	1.27

LM317M, LM317MA

OUTLINE DIMENSIONS

DT SUFFIX
PLASTIC PACKAGE
CASE 369A-13
(DPAK)
ISSUE Y

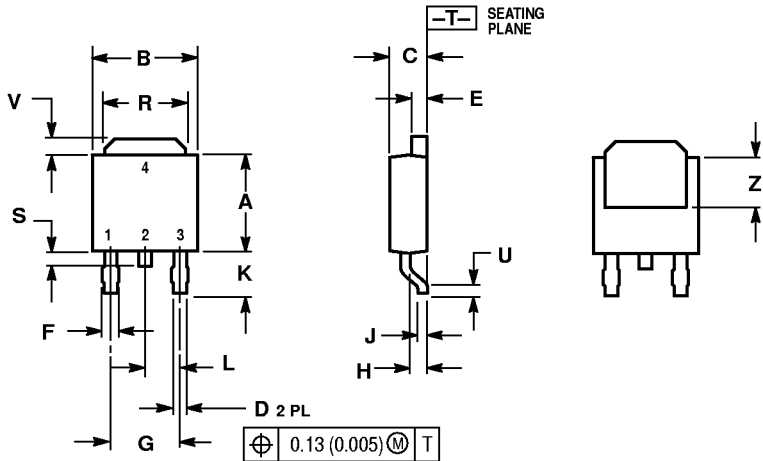

NOTES:

1. DIMENSIONING AND TOLERANCING PER ANSI Y14.5M, 1982.
2. CONTROLLING DIMENSION: INCH.

DIM	INCHES		MILLIMETERS	
	MIN	MAX	MIN	MAX
A	0.235	0.250	5.97	6.35
B	0.250	0.265	6.35	6.73
C	0.086	0.094	2.19	2.38
D	0.027	0.035	0.69	0.88
E	0.033	0.040	0.84	1.01
F	0.037	0.047	0.94	1.19
G	0.180 BSC		4.58 BSC	
H	0.034	0.040	0.87	1.01
J	0.018	0.023	0.46	0.58
K	0.102	0.114	2.60	2.89
L	0.090 BSC		2.29 BSC	
R	0.175	0.215	4.45	5.46
S	0.020	0.050	0.51	1.27
U	0.020	—	0.51	—
V	0.030	0.050	0.77	1.27
Z	0.138	—	3.51	—

Motorola reserves the right to make changes without further notice to any products herein. Motorola makes no warranty, representation or guarantee regarding the suitability of its products for any particular purpose, nor does Motorola assume any liability arising out of the application or use of any product or circuit, and specifically disclaims any and all liability, including without limitation consequential or incidental damages. "Typical" parameters which may be provided in Motorola data sheets and/or specifications can and do vary in different applications and actual performance may vary over time. All operating parameters, including "Typicals" must be validated for each customer application by customer's technical experts. Motorola does not convey any license under its patent rights nor the rights of others. Motorola products are not designed, intended, or authorized for use as components in systems intended for surgical implant into the body, or other applications intended to support or sustain life, or for any other application in which the failure of the Motorola product could create a situation where personal injury or death may occur. Should Buyer purchase or use Motorola products for any such unintended or unauthorized application, Buyer shall indemnify and hold Motorola and its officers, employees, subsidiaries, affiliates, and distributors harmless against all claims, costs, damages, and expenses, and reasonable attorney fees arising out of, directly or indirectly, any claim of personal injury or death associated with such unintended or unauthorized use, even if such claim alleges that Motorola was negligent regarding the design or manufacture of the part. Motorola and $\text{\textcircled{M}}$ are registered trademarks of Motorola, Inc. Motorola, Inc. is an Equal Opportunity/Affirmative Action Employer.

Mfax is a trademark of Motorola, Inc.

How to reach us:

USA/EUROPE/Locations Not Listed: Motorola Literature Distribution;
P.O. Box 5405, Denver, Colorado 80217. 1-303-675-2140 or 1-800-441-2447

JAPAN: Nippon Motorola Ltd.: SPD, Strategic Planning Office, 141,
4-32-1 Nishi-Gotanda, Shagawa-ku, Tokyo, Japan. 03-5487-8488

Customer Focus Center: 1-800-521-6274

Mfax™: RMFAX0@email.sps.mot.com – TOUCHTONE 1-602-244-6609
Motorola Fax Back System – US & Canada ONLY 1-800-774-1848

ASIA/PACIFIC: Motorola Semiconductors H.K. Ltd.; 8B Tai Ping Industrial Park,
51 Ting Kok Road, Tai Po, N.T., Hong Kong. 852-26629298

HOME PAGE: <http://motorola.com/sps/>

