

---

---

# 液晶显示模组规格书

## SPECIFICATION FOR LCM MODULE

客户名称(Customer Name)：	
客户料号(Customer P/N.)：	
模组型号(MDA P/N.)：	LM32019P2
物料编号(MDA C/N.)：	10101183
文件号(Version No.)：	A1
日期(Date)：	2014-02-18

公司签核 (Signature)	管理者 (Manager)	市场 (Sales)	工程 (Engineering)	品保 (QA)

客户确认 (Customer approval)	
-----------------------------	--

- ※ 本公司承诺所销售产品的品质与所送样品一致  
We promise that our products conform to the sample furnished in quality.
- ※ 若对试样产品的品质有特殊要求，请与本公司销售工程师联系。  
In case of any special requirement on the quality, please feel free to contact our sales engineers.
- ※ 感谢您给予本公司送样承认的机会，烦请将此表签回本公司便于归档。  
Thanks for awarding this opportunity of sample approval, please return this form to us for filing after authentication.

## 目 录 Contents

1 · 模组规格	Functions & Features·····	2
2 · 机械尺寸	Mechanical specifications·····	2
3 · 原理框图	Block diagram·····	2
4 · 模组外形图	Dimensional Outline·····	3
5 · 接口定义	Pin description·····	3
6 · 极限参数	Absolute Maximum limit·····	4
7 · 电性参数	Electrical characteristics·····	4
8 · 光电特性	Electrol-Optical characteristics·····	5
9 · 时序特性	Timing Characteristics·····	6~9
10 · 品质保证	Quality Assurance·····	10~15
11 · 注意事项	Precaution for using LCD/LCM·····	16~17

## 版本记录 Revision History

版本 Revision#	日期 Date	描述 Description	编制 Organizer
A0	2010-11-26	初始 Original	keguodong
A1	2014-02-15	Updates	keguodong

### 1、模组规格 Functions & Features

视角 Viewing direction	6:00		
LCD 模式 LCD mode	FSTN, Negative, Black , Transmissive		
驱动方式 Driving scheme	占空比(Duty) : 1/240 偏压比(Bias) : 1/16		
背光颜色 Backlight color	CCFL,White		
驱动电压(VDD)	5.0V	LCD 电压(VLCD)	21.0V(Ref.)
工作温度 Operation temp	-20~70°C	储存温度 Storage temp	-30~80°C

### 2、机械尺寸 Mechanical specifications

项目 Item	尺寸 Dimension	单位 Unit
显示容量 Number of Characters	320x240	Dots
模组尺寸 Module size	167(L)* 109 (W)*7.5 (H)max	mm
可视区域 Viewing area	122(L)*92(W)	mm
点间距 Dot pitch	0.36(L)*0.36(W)	mm
点大小 Dot size	0.33(L)*0.33(W)	mm

### 3、原理框图 Block diagram

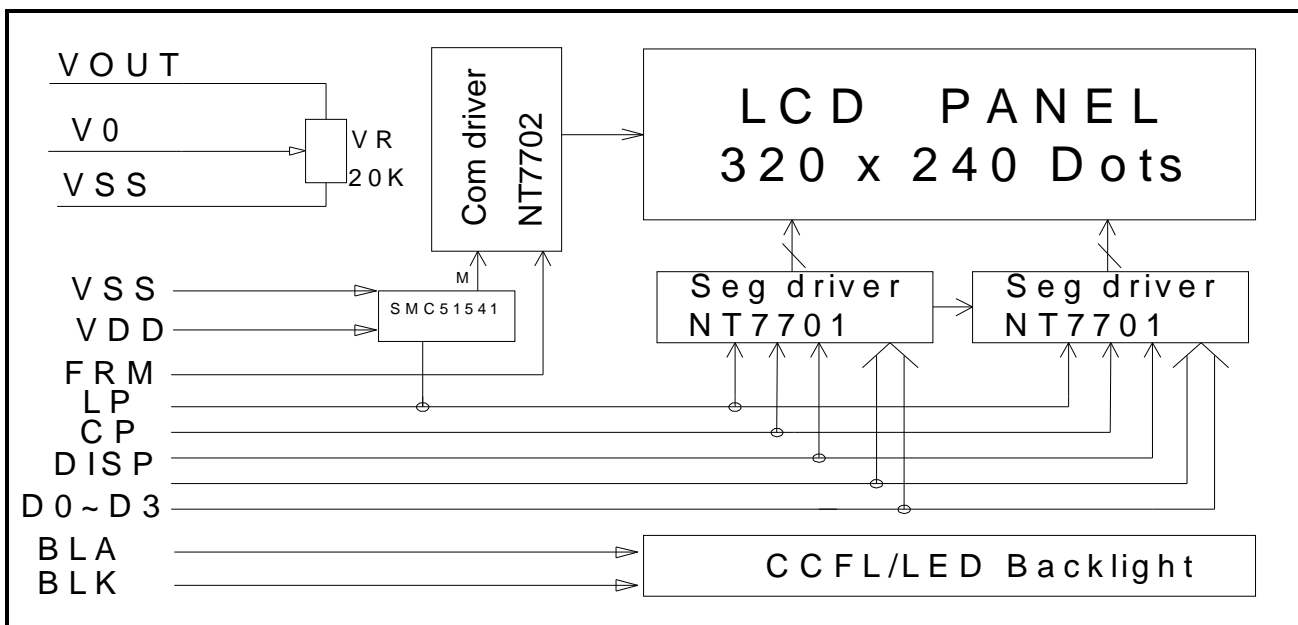

## 4、模组外形图 Dimensional outline

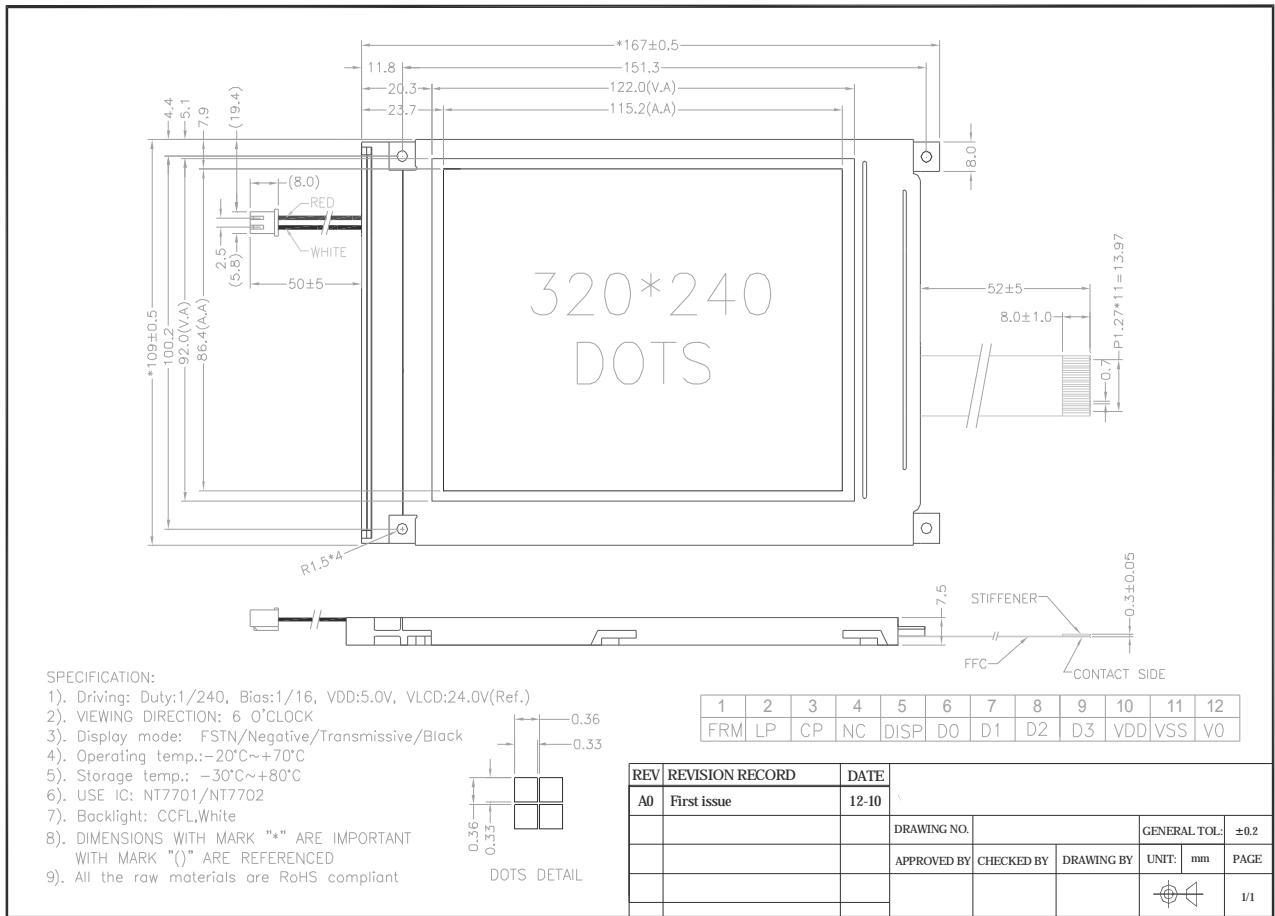

## 5、接口定义 Pin description

项目 Item	标号 Symbol	描述 Function
1	FRM	Frame signal(每一帧的开始)
2	LP	Data Latch Pulse(数据锁存信号)
3	CP	Data shift Pulse(数据移位信号)
4	NC	No connection(空脚)
5	DISP	Display ON/OFF (显示开关)
6~9	D0~D3	Data bus lines(数据线)
10	VDD	Power supply for Logic 电源正(+5V)
11	VSS	Power Ground 电源地(0V)
12	V0	Power supply for the LCD drive 对比度调节端

## 6、极限参数 Absolute Maximum limit

项目 Item	符号 Symbol	最小值 MIN	最大值 MAX	单位 Unit
驱动电压 Supply Voltage for Logic	VDD	0	5.5	V
LCD 电压 Supply Voltage for LCD	VLCD	0	28	V
输入电压 Input Voltage	Vin	0	VDD	V
工作温度 Operating Temperature	Top	-20	70	°C
储存温度 Storage Temperature	Tstr	-30	80	°C

## 7、电性参数 Electrical characteristics

项目 Item	符号 Symbol	条件 Condition	最小值 MIN	典型值 Typ	最大值 MAX	单位 Unit
逻辑电压 Supply Voltage for Logic	VDD-VSS	Ta = 25°C	4.75	5.0	5.25	V
输入高电压 Input High Voltage	VIH	Ta = 25°C	0.8VDD	---	VDD	V
输入低电压 Input Low Voltage	VIL	Ta = 25°C	0	---	0.2VDD	V
输出高电压 Output High Voltage	VOH	Ta = 25°C	VDD-0.4	---	VDD	V
输出低电压 Output Low Voltage	VOL	Ta = 25°C	0	---	0.4	V
Lamp Voltage 背光电压	VL	Ta = 25°C		250		V
背光电流 Lamp Current	IL	Ta = 25°C	4.0	5.0	6.0	mA
背光驱动频率 Lamp Frequency	fBL	Ta = 25°C	30	75	85	kHz
模块电流 Supply Current	IDD	Ta = 25°C	---	5.0	---	mA

Note: Starting discharge voltage is increased when LCM is operating at lower temperature. Please check the characteristics of inverter before applying

## 8、光电特性 Electro-Optical characteristics

项目 Item	标号 Symbol	条件 Condition	最小 MIN	典型 Typ	最大 MAX	单位 Unit
工作电压 Operating Voltage	Vop	Ta = -20°C	---	---	---	V
		Ta = +25°C	20.7	21.0	21.3	
		Ta = +70°C	---	---	---	
响应时间 Response time	Tr	Ta = 25°C	---	185	---	ms
	Tf		---	200	---	ms
对比度 Contrast Ratio	Cr	Ta = 25°C	---	4	---	---
视角范围 Viewing angle range	$\theta$	$Cr \geq 2$	-30	---	+40	deg
	$\Phi$		-30	---	+30	deg

### Definition of Operation Voltage (Vop)

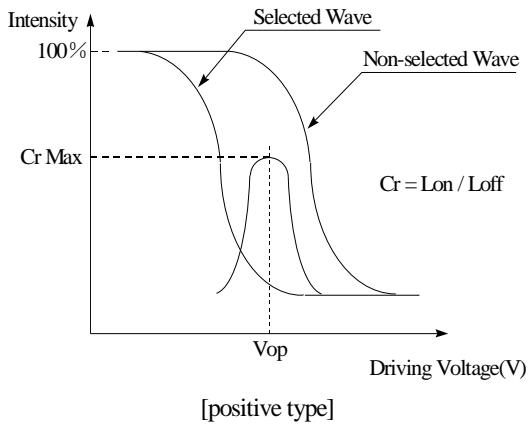

### Definition of Response Time (Tr, Tf)

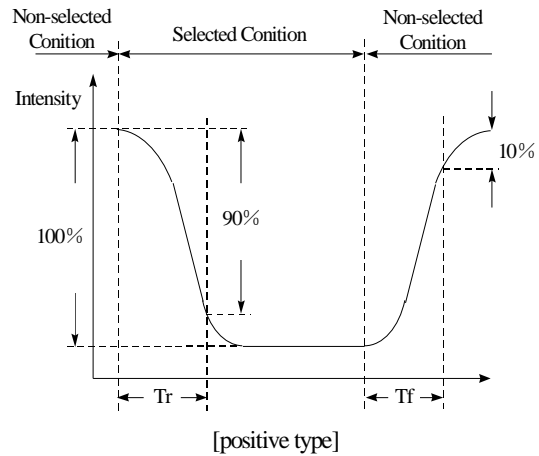

Conditions :

Operating Voltage : Vop  
Frame Frequency : 64 HZ

Viewing Angle( $\theta$  ,  $\varphi$ ) : 0° , 0°  
Driving Waveform : 1/N duty , 1/a bias

### Definition of viewing angle( $CR \geq 2$ )

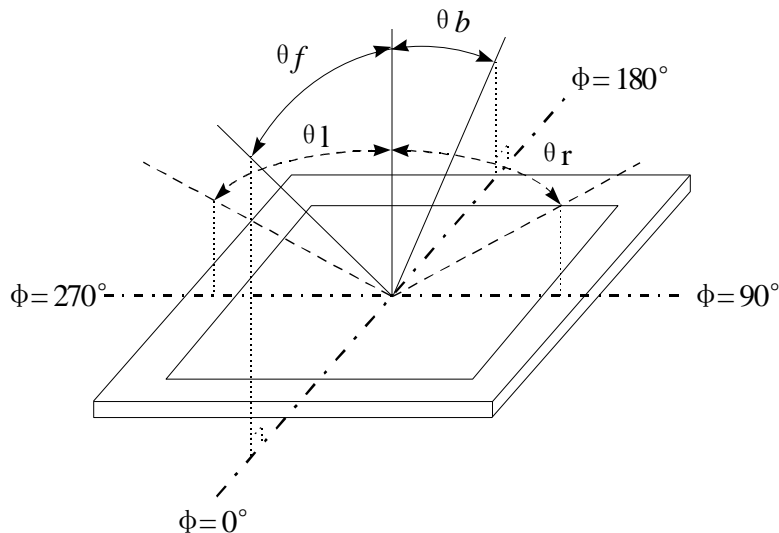

## 9、时序特性 Timing characteristics

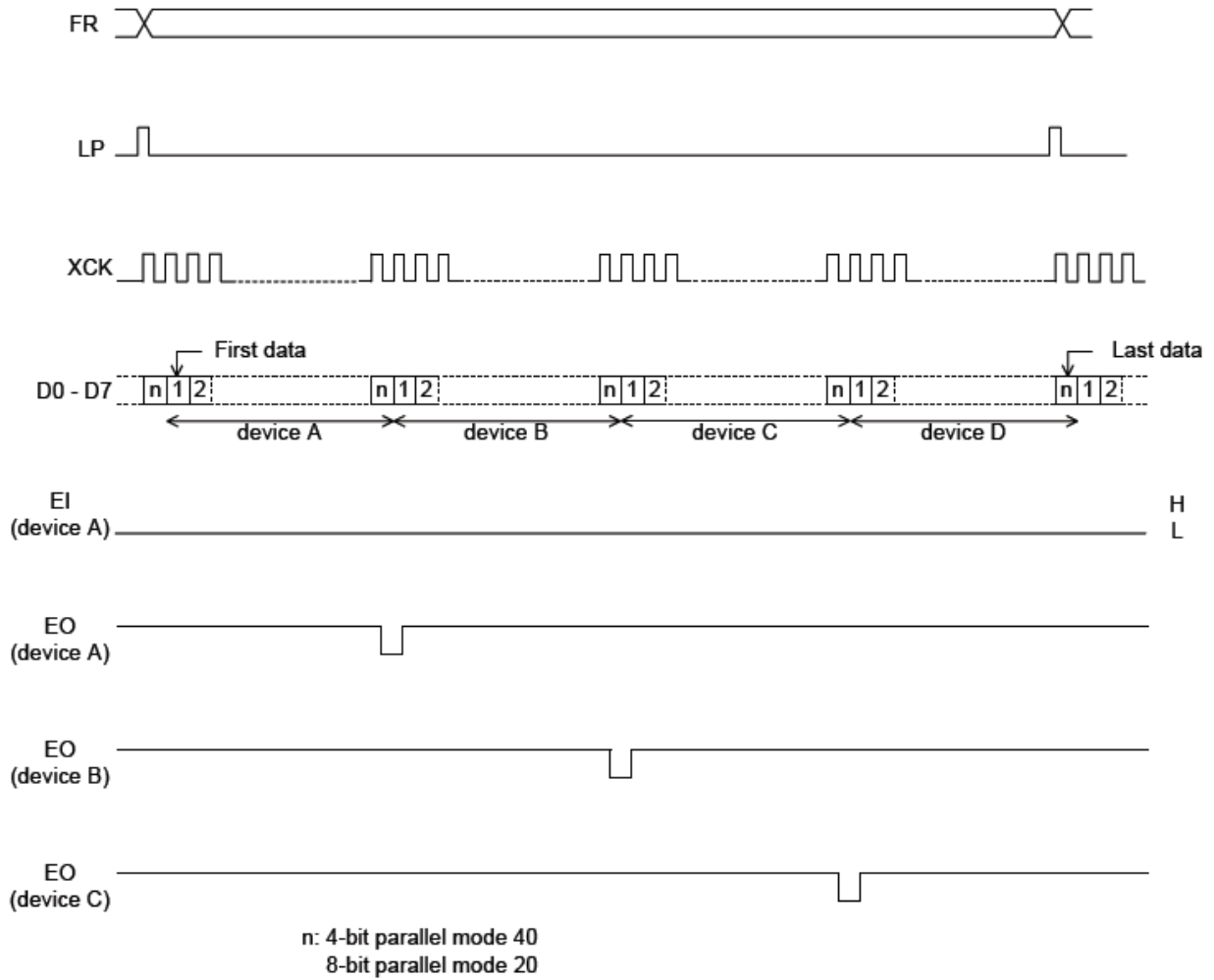

SPECIFICATION FOR LCM MODULE

Timing waveform of the Segment Mode

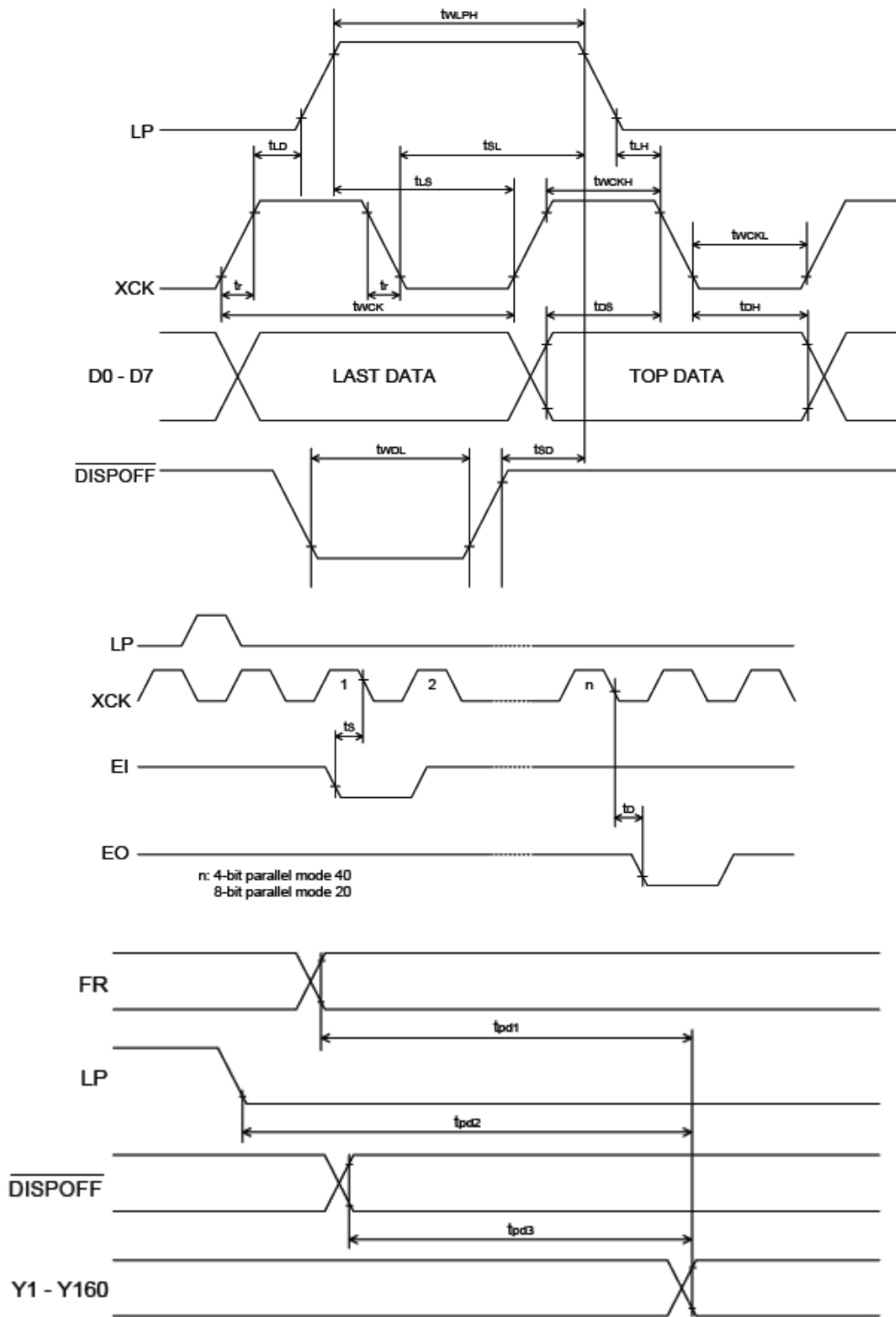



**SPECIFICATION FOR LCM MODULE**

Segment Mode 2 ( $V_{SS} = V_5 = 0V$ ,  $V_{DD} = 2.5 - 4.5V$ ,  $V_0 = 15$  to  $30$ , and  $T_A = -30$  to  $+85^\circ C$ , unless otherwise noted)

Parameter	Symbol	Min.	Typ.	Max.	Unit	Condition
Shift clock period	twck	125	-		ns	$t_r, t_f \leq 11ns$ , Note 1
Shift clock "H" pulse width	twckH	51	-		ns	
Shift clock "L" pulse width	twckL	51	-		ns	
Data setup time	tds	30	-		ns	
Data hole time	tdh	40	-		ns	
Latch pulse "H" pulse width	twLPH	51	-		ns	
Shift clock rise to Latch pulse rise time	tLD	0	-		ns	
Shift clock fall to Latch pulse fall time	tsL	51	-		ns	
Latch pulse rise to Shift clock rise time	tLS	51	-		ns	
Latch pulse fall to Shift clock fall time	tLH	51	-		ns	
Input signal rise time	$t_r$		-	50	ns	Note 2
Input signal fall time	$t_f$		-	50	ns	Note 2
Enable setup time	ts	36	-		ns	
$\overline{DISPOFF}$ Removal time	tsD	100	-		ns	
$\overline{DISPOFF}$ enable pulse width	twDL	1.2	-		$\mu s$	
Output delay time (1)	td		-	78	ns	$C_L = 15pF$
Output delay time (2)	$t_{pd1}, t_{pd2}$		-	1.2	$\mu s$	$C_L = 15pF$
Output delay time (3)	$t_{pd3}$		-	1.2	$\mu s$	$C_L = 15pF$

Note

1. Take the cascade connection into consideration.
2.  $(t_{ck} - tw_{ckH} - tw_{ckL})/2$  is the maximum in the case of high speed operation.

Common Mode ( $V_{SS} = V_5 = 0V$ ,  $V_{DD} = 2.5 - 5.5V$ ,  $V_0 = 15$  to  $30V$  and  $T_A = -30$  to  $+85^\circ C$ , unless otherwise noted)

Parameter	Symbol	Min.	Typ.	Max.	Unit	Condition
Shift clock period	twLP	250	-	-	ns	$t_r, t_f \leq 20ns$
Shift clock "H" pulse width	twLPH	15	-	-	ns	$V_{DD} = +5.0V \pm 10\%$
		30	-	-	ns	$V_{DD} = +2.5 - +4.5V$
Data setup time	tsu	30	-	-	ns	
Data hole time	th	50	-	-	ns	
Input signal rise time	$t_r$		-	50	ns	
Input signal fall time	$t_f$		-	50	ns	
$\overline{DISPOFF}$ Removal time	tsD	100	-	-	ns	
$\overline{DISPOFF}$ enable pulse width	twDL	1.2	-	-	$\mu s$	
Output delay time (1)	tdL	-	-	200	ns	$C_L = 15pF$
Output delay time (2)	$t_{pd1}, t_{pd2}$	-	-	1.2	$\mu s$	$C_L = 15pF$
Output delay time (3)	$t_{pd3}$	-	-	1.2	$\mu s$	$C_L = 15pF$

**Timing Characteristics of Common Mode**

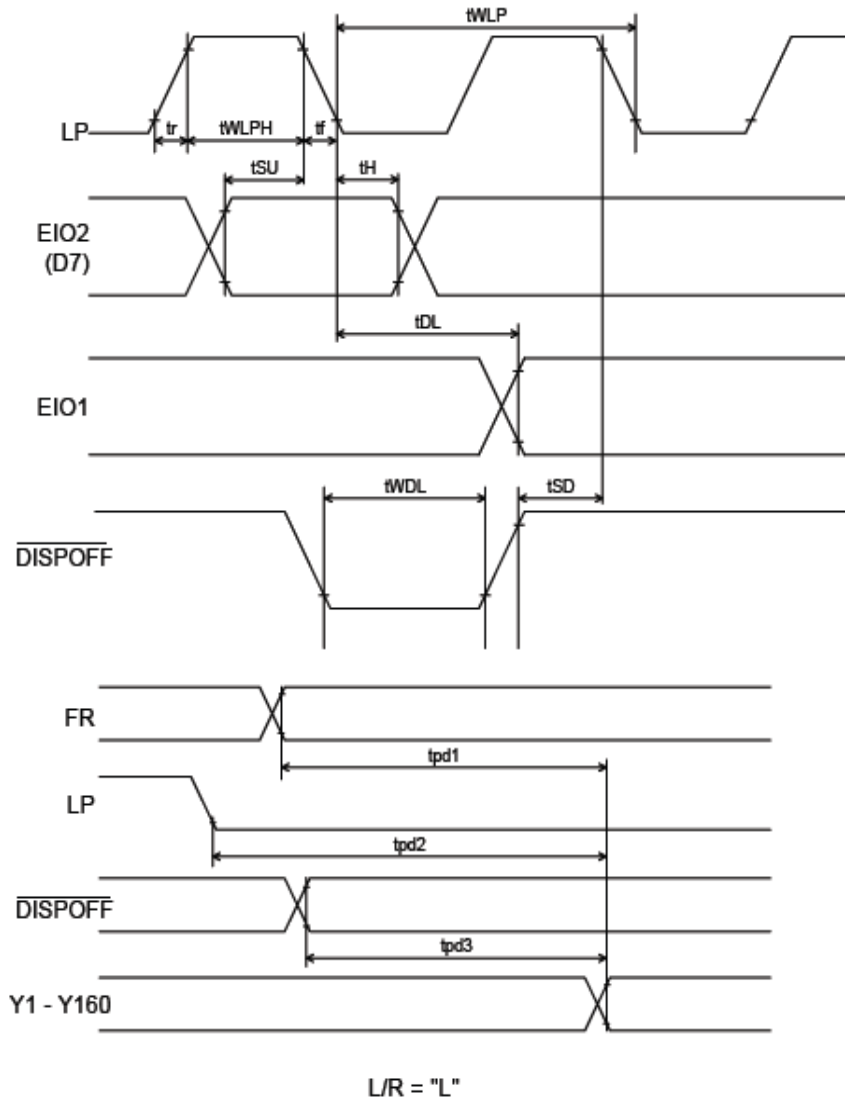

## 10. 品质保证 Quality Assurance

• Our company is qualified through ISO9001:2008 ( Certificate NO.: 04910Q10923R0S ). Our production plant has stringent quality control to guarantee absolute product quality. release and acceptance of finished LCM products in order to guarantee the quality required by the customer.

### 1 • Scope

The criteria are applicable to all the LCM products manufactured by MDA, either supplied alone or embedded in or integrated with other components.

### 2 • Inspection Apparatuses

Function testers, vernier calipers, microscopes, magnifiers, ESD wrist straps, finger cots, labels, ovens for high-low temperature tests, refrigerators, constant voltage power supply ( DC ) , desk lamps, etc.

### 3 • Reference Standards

3.1.1 GB/T 1619.96 Test Methods for TN LCD.

3.1.2 GB/T 12848.91 General Specifications for STN LCD.

3.1.3 GB2421-89 Basic Environmental Test Procedures for Electrical and Electronic Products

3.1.4 IPC-A-610C Acceptance Condition for Electrical Assemblies.

3.1.5 IEC-61000-4-2 Electrostatic Discharge immunity Tests

3.1.6 CISPR 22 Class B Conductive & Radiation limits

### 4 • Inspection Conditions and Inspection Reference

4.1 Cosmetic inspection: shall be done normally at  $25\pm 5^{\circ}\text{C}$  of the ambient temperature and  $45\pm 20\%\text{RH}$  of relative humidity, under the ambient luminance greater than  $300\text{cd}/\text{cm}^2$  and at the distance of 30cm apart between the inspector' s eyes and the LCD panel and normally in reflected light. For back-lit LCMs, cosmetic inspection shall be done under the ambient luminance less than  $100\text{cd}/\text{cm}^2$  with the backlight on.

4.2 The LCM shall be tested at the angle of  $45^{\circ}$ , left and right, and  $0-45^{\circ}$ , top and bottom (for STN LCM, at  $20-55^{\circ}$ ) .

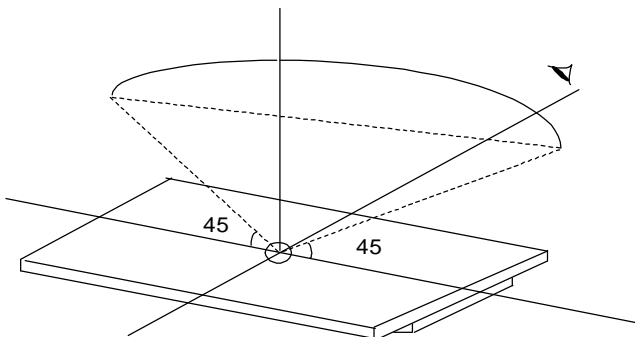

4.3 Definition of VA

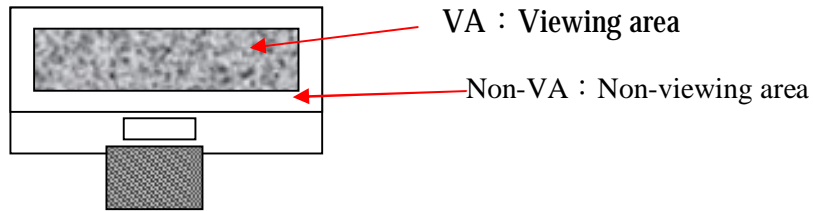

4.4 Inspection with naked eyes ( exclusive of the inspection of the physical dimensions of defects carried out with magnifiers ) .

4.5 Electrical properties

Inspection with the test jigs against the product specifications or drawings; display contents and parameters shall conform to those of the product specifications and the display effect to the sample.

4.5.1 Test voltage ( V ) :

4.5.1.1 (Determined) according to the operating instruction of test jigs assuming the external circuit can be adjusted unless the customer otherwise specifies driving voltage(s). (Display) effects are controlled within the specified range of voltage variation (If no specific requirements, display effects are controlled at  $V_{op} = 9V$  or  $V_{op} \pm 0.3V$  when  $V_{op}$  is below 9V; if  $V_{op}$  is above 9V, display effects are controlled at  $V_{op} \pm 0.3\%$  at least). For display products with the customer-specified fixed  $V_{op}$ , display effects are controlled by adjusting the internal circuit; if necessary, acceptable limit samples shall be built.

4.5.2 Current Consumption ( I ) : refer to approved product specifications or drawings.



5 · Defects and Acceptance Standards

5.1 Dimensions : the outline dimensions and the dimensions that could influence the assembly at the customer' s side shall conform to those on the approved drawings.

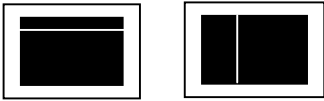
5.2 Main Defects - Functionality Tests:

No.	Item	Description	MAJ	MIN	Acceptance Criteria
5.2.1	Missing Segments	Missing segments or dots caused by broken contact(s), loose connection or an internal open circuit. 	√		Rejected
5.2.3	No display /Inaction	No segments, icons or graphics are displayed when the LCM is connected correctly.	√		Rejected
5.2.4	Mis-Display	Display pattern is deformed or jumbled-up	√		Rejected

SPECIFICATION FOR LCM MODULE

		under the normal scanning procedure.			
5.2.5	Wrong viewing angle	When powered up, the viewing angle at which the display is at its clearest is different from the required viewing angle or that of the approved samples. )	√		Rejected
5.2.6	Dim or Dark Display	Overall contrast is either too dark or too dim under normal operation.	√		If out of the voltage tolerance, Rejected
5.2.7	Slow response	Local response time varies when LCM is turned on or off.	√		Rejected
5.2.8	Extra segments, rows, or columns	Icons, traces, rows or columns that should not appear on the LCD screen and caused by LCD panel misalignment or insufficient corrosion.		√	Refer to dot/line standard
5.2.9	Dim segment	Under the normal voltage, the contrast of vertical and horizontal segments is uneven.		√	Reject or refer to samples
5.2.10	PI black/white spots	Partial black and white spots visible when changing display contents due to defective PI layer.		√	refer to the spot/line criteria for the visible spots when display image remains still; others OK.
5.2.11	pinhole/white spots	Deformed patterns appearing when LCD is turned on caused by missing ITO.  $d = (X+Y)/2$		√	refer to spot/line standard
5.2.12	Pattern distortion	Segment is either wider , narrower or deformed than the specified, caused by panel misalignment, resulting in unwanted heave(s) or missing: $ Ia-Ib  \leq 1/4W$ (W is the normal width) 		√	Acceptable $ Ia-Ib  > 1/4W$ , rejected
5.2.13	High current	LCM current is larger than the designed value.		√	Rejected

5.3 LCD Visual Defects

5.3.1 Spot defect (defined within VA, spots out of VA do not count.)

Defect	Average diameter ( d )	Acceptable quantity	MAJ	MIN
Spot defect ( black spot, foreign matter, nick, scratches, including LC mis-orientation. )	$d \leq 0.2$	3		√
	$0.2 < d \leq 0.25$	2		
	$0.25 < d \leq 0.30$	1		

5.3.2 Line defects (defined within VA; those out of VA do not count.)

Defect	Length(L)	Width(W)	Acceptable quantity	MAJ	MIN
line defects (scratches, linear foreign matter) 	$\leq 5.0$	$\leq 0.02$	3		√
	$\leq 3.0$	$\leq 0.03$	3		
	$\leq 3.0$	$\leq 0.05$	1		

note : 1.If the width is bigger than 0.1mm, it shall be treated as spot defect.

5.3.3 Polarizer air bubble (defined within VA; those out of VA do not count.)

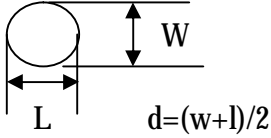
Defect	Average diameter ( d )	Acceptable quantity	MAJ	MIN
Polarizer air bubble, Concave-Convex dot. 	$d \leq 0.3$	3		√
	$0.3 < d \leq 0.5$	2		
	$0.5 < d \leq 0.8$	1		

5.4 Backlight

No.	Item	Description	MAJ	MIN	Accept standard
5.4.1	Backlight not working, wrong color	/	√		Rejected
5.4.2	Color deviation	When powered on, the LCD color differs from that of the sample and is found after testing not conforming to the drawing.		√	Refer to sample and drawing
5.4.3	Brightness deviation	When powered on, the LCD brightness differs from that of the sample and is found after testing not conforming to the drawing; or if conforming to the drawing but over $\pm 30\%$ .		√	Refer to sample and drawing

SPECIFICATION FOR LCM MODULE

5.4.4	Uneven brightness	When powered on, the LCD brightness is uneven on the same LCD and out of the specification of the drawing.		√	Refer to sample and drawing
5.4.5	Spot/line scratch	Appearance of spot or line scratches on the LCD when turned on.		√	Refer to 6.3.1/6.3.2

5.5 Metal frame (Metal Bezel)

No.	Item	Description	MAJ	MIN	Accept standard
5.5.1	Material/surface treatment	Metal frame/surface treatment do not conform to the specifications.	√		Rejected
5.5.2	Tab twist inconformity/ Tab not twisted	Wrong twist method or direction and twist tabs are not twisted as required.	√		Rejected
5.5.3	Oxidization, chapped paint, discoloration, dents, and scratches	Oxidation on the surface of the metal bezel ; the quantity of spot defect (chapped front surface paint and substrate-exposing scratches) $\leq 0.8\text{mm}$ exceeds 3; the quantity of linear defects with the length $\leq 5.0\text{mm}$ and width $\leq 0.05\text{mm}$ exceeds 2; the quantity of spot defect (front dent, bubble, side surface chapped paint and substrate-exposing scratches) $\leq 1.0\text{mm}$ exceeds 3; the quantity of linear defects with the width $\leq 0.05\text{mm}$ exceeds 3.		√	Rejected
5.5.4	Burr	Burr(s) on metal bezel is so long as to get into viewing area.		√	Rejected

5.6 SMT (Refer to IPC-A-610C if not specified)

No.	Item	Description	MAJ	MIN	Accept standard
5.6.1	Soldering solder defects	Cold, false and missing soldering, solder crack and insufficient solder dissolution.		√	Rejected
5.6.2	Solder ball/splash	Solder ball/tin dross causing short at the solder point.		√	Rejected
5.6.3	DIP parts	Floated or tilted DIP parts , keypad , connectors.		√	Rejected
5.6.4	Solder shape	The welded spot should be concave and excessive or insufficient solder or solder burr on the welded spot must be rejected.		√	Rejected

**SPECIFICATION FOR LCM MODULE**

5.6.5	Component pin exposure	For the DIP type components, 0.5~2mm component pin must be remained after cutting the soldered pin, and the solder surface should not be damaged nor should the component pin is fully covered with solder; otherwise rejected.		√	Reject
5.6.6	Poor Appearance	Caused by yellow-brown or black solder flux or resin or the white mist at the solder point caused by PCB cleaning.		√	reject

**6 · Reliability test**

Notes : ①Reliability tests shall be done as required by the customer if they inform MDA of their special requirements when starting a project.

Test item	Condition	Time(hrs)	Acceptance standard
High Storage Temp.	80°C	120	Functions and appearance are qualified before and after test
High Operating Temp.	70°C	120	
Low Storage Temp.	-20°C	120	
Low Operating Temp.	-30°C	120	
Temp& Humidity Test	40°C/ 90%RH	120	
Thermal Shock	-20°C ← 25°C →+70°C (30 min ← 5 min → 30min)	10 cycles	

②Storage test at high-low temperature and functionality test shall be done with reference to the specified temperature range.

③Test conditions shall be controlled at the permissible tolerance of ±5°C.

**7 · Packing**

Guarantee to offer ESD shield bag to protect the product from electrostatic or magnetic interference during delivery

**8 · Others**

8.1 Items not specified in this document or released on compromise should be inspected with reference to the mutual agreement and limit samples.



## 11. 注意事项 Precaution for using LCD/LCM

After reliability test, recovery time should be 24 hours minimum. Moreover, functions, performance and appearance shall be free from remarkable deterioration within 50,000 hours ( average ) under ordinary operating and storage conditions room temperature (20±8°C), normal humidity (below 65% RH), and in the area not exposed to direct sun light. Using LCM beyond these conditions will shorten the life time.

### Precaution for using LCD/LCM

MDA LCD/LCM is assembled and adjusted with a high degree of precision. Do not attempt to make any alteration or modification. The followings should be noted.

#### General Precautions:

1. LCD panel is made of glass. Avoid excessive mechanical shock or applying strong pressure onto the surface of display area.
2. The polarizer used on the display surface is easily scratched and damaged. Extreme care should be taken when handling. To clean dust or dirt off the display surface, wipe gently with cotton, or other soft material soaked with isopropyl alcohol, ethyl alcohol or trichlorotrifluoroethane, do not use water, ketone or aromatics and never scrub hard.
3. Do not tamper in any way with the tabs on the metal frame.
4. Do not make any modification on the PCB without consulting MDA.
5. When mounting a LCM, make sure that the PCB is not under any stress such as bending or twisting. Elastomer contacts are very delicate and missing pixels could result from slight dislocation of any of the elements.
6. Avoid pressing on the metal bezel, otherwise the elastomer connector could be deformed and lose contact, resulting in missing pixels and also cause rainbow on the display.
7. Be careful not to touch or swallow liquid crystal that might leak from a damaged cell. Any liquid crystal adheres to skin or clothes, wash it off immediately with soap and water.

#### Static Electricity Precautions:

1. CMOS-LSI is used for the module circuit; therefore operators should be grounded whenever he/she comes into contact with the module.
2. Do not touch any of the conductive parts such as the LSI pads; the copper leads on the PCB and the interface terminals with any parts of the human body.
3. Do not touch the connection terminals of the display with bare hand; it will cause disconnection or defective insulation of terminals.
4. The modules should be kept in anti-static bags or other containers resistant to static for storage.

5. Only properly grounded soldering irons should be used.
6. If an electric screwdriver is used, it should be grounded and shielded to prevent sparks.
7. The normal static prevention measures should be observed for work clothes and working benches.
8. Since dry air is inductive to static, a relative humidity of 50-60% is recommended.

**Soldering Precautions:**

1. Soldering should be performed only on the I/O terminals.
2. Use soldering irons with proper grounding and no leakage.
3. Soldering temperature:  $350^{\circ}\text{C} \pm 10^{\circ}\text{C}$
4. Soldering time: 3 to 4 second.
5. Use eutectic solder with resin flux filling.
6. If flux is used, the LCD surface should be protected to avoid spattering flux.
7. Flux residue should be removed.

**Operation Precautions:**

1. The viewing angle can be adjusted by varying the LCD driving voltage  $V_o$ .
2. Since applied DC voltage causes electro-chemical reactions, which deteriorate the display, the applied pulse waveform should be a symmetric waveform such that no DC component remains. Be sure to use the specified operating voltage.
3. Driving voltage should be kept within specified range; excess voltage will shorten display life.
4. Response time increases with decrease in temperature.
5. Display color may be affected at temperatures above its operational range.
6. Keep the temperature within the specified range usage and storage. Excessive temperature and humidity could cause polarization degradation, polarizer peel-off or generate bubbles.
7. For long-term storage over  $40^{\circ}\text{C}$  is required, the relative humidity should be kept below 60%, and avoid direct sunlight.

**Limited Warranty**

MDA LCDs and modules are not consumer products, but may be incorporated by MDA's customers into consumer products or components thereof, MDA does not warrant that its LCDs and components are fit for any such particular purpose.

1. The liability of MDA is limited to repair or replacement on the terms set forth below. MDA will not be responsible for any subsequent or consequential events or injury or damage to any personnel or user including third party personnel and/or user. Unless otherwise agreed in writing between MDA and the customer, MDA will only replace or repair any of its LCD which is found defective electrically or visually when inspected in accordance with MDA general LCD inspection standard . (Copies available on request)
2. No warranty can be granted if any of the precautions state in handling liquid crystal display above has been disregarded. Broken glass, scratches on polarizer mechanical damages as well as defects that are caused accelerated environment tests are excluded from warranty.
3. In returning the LCD/LCM, they must be properly packaged; there should be detailed description of the failures or defect.