

LM32019P

Medium size B/W STN LCD Module

(Model Number: LM32019P)

Specifications

Spec No.: LC97306A

Dated: May 31. 2002

NOTICE

This publication is the proprietary of SHARP and is copyrighted, with all rights reserved. Under the copyright laws, no part of this publication may be reproduced or transmitted in any form or by any means, electronic or mechanical for any purpose, in whole or in part, without the express written permission of SHARP. Express written permission is also required before any use of this publication may be made by a third party.

The application circuit examples in this publication are provided to explain the representative applications of SHARP's devices and are not intended to guarantee any circuit design or permit any industrial property right or other rights to be executed. SHARP takes no responsibility for any problems related to any industrial property right or a third party resulting from the use of SHARP's devices, except for those resulting directly from device manufacturing processes.

In the absence of confirmation by device specification sheets, SHARP takes no responsibility for any defects that occur in equipment using any of SHARP's devices, shown in catalogs, data books, etc. Contact SHARP in order to obtain the latest device specification sheets before using any SHARP's device.

SHARP reserves the right to make changes in the specifications, characteristics, data, materials, structures and other contents described herein at any time without notice in order to improve design or reliability. Contact SHARP in order to obtain the latest specification sheets before using any SHARP's device. Manufacturing locations are also subject to change without notice.

Observe the following points when using any device in this publication. SHARP takes no responsibility for damage caused by improper use of the devices.

The devices in this publication are designed for use in general electronic equipment designs, such as:

- Automotive auxiliary information display
- Automotive audio visual equipment

The appropriate design measures should be taken to ensure reliability and safety when SHARP's devices are used for equipment such as:

- Transportation control and safety equipment(i.e., aircraft, trains, automobiles, etc.)
- Traffic signals • Gas leakage sensor breakers
- Alarm equipment • Various safety devices etc.

SHARP's devices shall not be used for equipment that requires extremely high level of reliability, such as:

- Military and space applications • Nuclear power control equipment
- Medical equipment for life support

Contact a SHARP representative, in advance, when intending to use SHARP's devices for any "specific" applications other than those recommended by SHARP.

Contact and consult with a SHARP representative if there are any questions about the contents of this publication.

PREPARED BY: DATE	SHARP LIQUID CRYSTAL DISPLAY GROUP SHARP CORPORATION SPECIFICATION	SPEC No. LC97306A
APPROVED BY: DATE		FILE No.
		ISSUED MAR. 12. 1997
		PAGE 19 Pages
		APPLICABLE DIVISION
		<input checked="" type="checkbox"/> DUTY PANEL DEVELOPMENT CENTER <input type="checkbox"/> TFT DEVELOPMENT CENTER <input type="checkbox"/> LCD PRODUCTS DEVELOPMENT CENTER <input type="checkbox"/> EL PRODUCTION DEPT.

SPECIFICATION FOR
 Passive Matrix LCD Module

Model No.
LM32019P

CUSTOMER'S APPROVAL

DATE _____

BY _____

PRESENTED BY 

Y. Inoue
 Department General Manager
 Engineering Department 2
 DUTY Panel Development Center
 NARA Liquid Crystal Display Group
 SHARP Corporation

○Precautions

- 1) Especially the power ON/OFF sequence shown on Page.12 shall be followed to avoid latch-up of drive LSIs and application of DC voltage to LCD panel.
- 2) Industrial (Mechanical) design of the product in which this LCD module will be incorporated must be made that the viewing angle characteristics of the LCD may be optimized. Please consider the optimum viewing conditions according to the purpose when installing the module. (For the optical characteristics refer to the table.)
- 3) This module is installed using mounting holes at the four corners of module. When installing the module, pay attention and handle carefully not to allow any undue stress such as twist or bend.
A transparent acrylic resin board or other type of protective panel should be attached to the front of the module to protect the polarizer, LCD cells, etc.
- 4) Since the front polarizer is easily damaged. Please pay attention not to scratch on its face.
- 5) If the surface of the LCD cells needs to be cleaned, wipe it swiftly with cotton or other soft cloth. If still not completely clear, blow on its and wipe.
- 6) Water droplets, etc., must be wiped off immediately since they may cause color changes, staining, etc., if remained for a long time.
- 7) Since LCD is made of glass plates, dropping the module or banging it against hard objects may cause cracking or fragmentation.
- 8) Since CMOS LSIs are equipped in this module, following countermeasures must be taken to avoid electrostatics charge.

1. Operator

Electrostatic shielding clothes shall be use for fear that the static electricity human body in case that operator have a insulating garment.

2. Equipment

There is a possibility that the static electricity is charged to equipment which have a function of peeling or mechanism of friction (EX:Conveyer, soldering iron, working table), so the countermeasure (electrostatic earth: $1 \times 10^8 \Omega$) should be made.

3. Humidity

Humidity of working room may lower electrostatics generating material's resistance and have something to prevent electrifying. So, humidity should be kept over 50 % because humidity less than 50 % may increase material's electrostatic earth resistance and it become easy to electrify.

4. Transportation/storage

The measure should be made for storage materials because there is a possibility that the static electricity, which electrify human body or storage materials like container by friction or peeling, cause the dielectric charge.

5. Other

The laminator is attached on the surface of LCD module to prevent from scratches, fouling and dust. It should be peeled off unhurriedly with using static eliminator.

9) Avoid to expose the module to the direct sun-light, strong ultraviolet light, etc. for a long time.

10) If stored at temperatures below specified storage temperature, the LC may freeze and be deteriorated. If storage temperatures exceed the specified rating, the molecular orientation of the LC may change to that of a liquid, and they may not revert to their original state.

11) Disassembling the LCD module can cause permanent damage and should be strictly avoided.

12) Don't use any materials that emit gas from epoxy resin (amines'herdener) and silicone adhesive agent (dealcohol or deoxym) to prevent change polarizer color owing to gas.

13) Since leakage current, which may be caused by routing of CCFT cables, etc., may affect the brightness of display, the inverter has to be designed taking the leakage current into consideration. Thorough evaluation of the LCD module/inverter built into its host equipment shall be conducted, therefore, to ensure the specified brightness.

14) This specification describes display quality in case of no gray scale. Since display quality can be affected by gray scale methods, display quality shall be carefully evaluated for the usability of LCD module in case gray scale is displayed on the LCD module.

○Contents

	Page
1. Application	4
2. Construction and Outline	4
3. Mechanical Specification	4
4. Absolute Maximum Ratings	
4-1. Electrical absolute maximum rating	5
4-2. Environment Conditions	5
5. Electrical Specification	
5-1. Interface signals	6
5-2. Electrical characteristics	7
5-3. Supply voltage sequence condition	12
6. Modules Driving Method	
6-1. Circuit configuration	13
6-2. Display face configuration	14
6-3. Input data and control signal	14
7. Optical Characteristics	15
8. Characteristics Backlight	17

1. Application

This data sheet is to introduce the specification of LM32019P, Passive Matrix type LCD module.

2. Construction and Outline

Construction: 320×240 dots display module consisting of a LCD panel, PWB (printed wiring board) with electric components mounted onto, TAB (tape automated bonding) to connect the LCD panel and PWB electrically, and plastic chassis with CCFT back light and bezels to fix them mechanically.

Outline : See Fig. 7

Connection : See Fig. 7 and Table 5

3. Mechanical Specifications

Table 1

Parameter	Specifications	Unit
Outline dimensions Note 1)	166.0 (W) × 109.0 (H) × 7.5 (D) MAX	mm
Viewing area	121.0 (W) × 91.6 (H)	mm
Active area	115.17 (W) × 86.37 (H)	mm
Display format	320 × 240 Dots	
Dot size	0.33 (W) × 0.33 (H)	mm
Dot spacing	0.03	mm
Base color Note 2)	Normally black Note 3)	-
Mass	160	g

Note 1) Excluded the mounting portions and connectors.

Note 2) Due to the characteristics of the LC material, the colors vary with environmental temperature.

Note 3) Negative-type display

Display data "H" : ON → transmission

Display data "L" : OFF → light isolation

4. Absolute Maximum Ratings

4-1 Electrical absolute maximum ratings

Table 2

Parameter	Symbol	MIN.	MAX.	Unit	Remark
Supply voltage (Logic)	VDD-VSS	0	7	V	Ta=25 °C
Supply voltage (LCD)	VDD-V0	0	32	V	Ta=25 °C
Input signal voltage	VIN-VSS	0	VDD	V	Ta=25 °C
Supply voltage (CCFT)	VL	0	1.500	V _{rms}	Ta=25 °C
Supply current (CCFT)	IL	0	6.5	mA _{rms}	Ta=25 °C

4-2 Environmental Conditions

Table 3

Item	Tstg.		Topr.		Remark
	MIN.	MAX.	MIN.	MAX.	
Ambient temperature	-25 °C	+60 °C	0 °C	+45 °C	Note 4)
Humidity	Note 1)		Note 1)		No condensation
Vibration	Note 2)		Note 2)		3 directions (X/Y/Z)
Shock	Note 3)		Note 3)		6 directions (±X±Y±Z)

Note 1) Ta ≤ 40 °C..... 95 % RH Max.

Ta > 40 °C..... Absolute humidity shall be less than

Ta=40 °C/95 % RH.

Note 2)

Table 4

Frequency	10 Hz~57 Hz	57 Hz~500 Hz
Vibration level	-	9.8 m/s ²
Vibration width	0.075 mm	-
Interval	10 Hz~500 Hz~10 Hz/11 min	

2 h for each direction of X/Y/Z (6 h as total)

Note 3) Acceleration : 490 m/s²

Pulse width : 11 ms

3 times for each direction of ±X/±Y/±Z

Note 4) Care should be taken so that the LCD module may not be subjected to the temperature out of this specification.

5. Electrical Specifications

5-1 Interface signals

Table 5-1 CN1(LCD)

Pin No	Symbol	Description	Level
1	S	Scan start-up signal	"H"
2	CP1	Input data latch signal	"H"→"L"
3	CP2	Data input clock signal	"H"→"L"
4	NC	-	-
5	DISP OFF	Display Control signal	"H" → Display ON
6	D0	Display data signal	"H" (ON), "L" (OFF)
7	D1		
8	D2		
9	D3		
10	VDD	Power supply for Logic	+5V
11	VSS	Ground potential	-
12	VEE	Power supply for LCD drive	(+16~27V)

Table 5-2 CN2(CCFT)

Pin No	Symbol	Description	Note
1	VFT1	Power supply for CCFT back light (HOT)	for Backlight
2	NC	-	
3	VFT2	Power supply for CCFT back light (GND)	

* Used Cable : AWG26 UL STILE 3579

Used connector CN1 : 12 pin , 1.25 mm pitch, FFC
 CN2 : BHR-03VS-1 (JST)

Mating connector CN1 : 5597-12APB, 5597-12CPB (MOLEX)
 CN2 : SM02 (8.0)-BHS-1-TB (JST)

5-2 Electrical characteristics of LCD panel

Table 6

Parameter	Symbol	Conditions	MIN.	TYP.	MAX.	Unit
Supply voltage (Logic)	VDD-VSS	Ta=0~45 °C	4.75	5	5.25	V
Supply voltage (LCD drive) Note 1)2)	VEE-VSS	Ta= 0 °C	19.1	21.3	23.5	V
		Ta= 25 °C	17.9	19.9	21.9	V
		Ta= 45 °C	17	18.9	20.8	V
Input signal voltage	VIN	"H" level	0.8VDD	-	VDD	V
		"L" level	0	-	0.2VDD	V
Input leakage current	IIL	"H" level	-	-	20	μA
		"L" level	-20	-	-	μA
Supply current (Logic)	IDD	Note 3)	-	1.2	1.8	mA
Supply current (LCD drive)	IEE		-	2	3	mA
Power consumption	Pd	Note 3)4)	-	46	70	mW

Note 1) The viewing angle θ at which the optimum contrast is obtained can be set by adjusting VEE-VSS. Refer to 7-Note 2 for the definition of θ .

Note 2) The voltage at which the optimum contrast is obtained (VEE-VSS) is different in individual modules. And it changes because of temperature. Therefore need adjust the voltage at which the optimum contrast is obtained (VEE-VSS) in individual modules.

Note 3) Under the following condition.:

VDD-VSS=5.0 V, VEE-VSS=Vmax (Refer to P.16 about Vmax)

Frame frequency=80 Hz, Ta=25 °C

Display pattern=1 bit checker

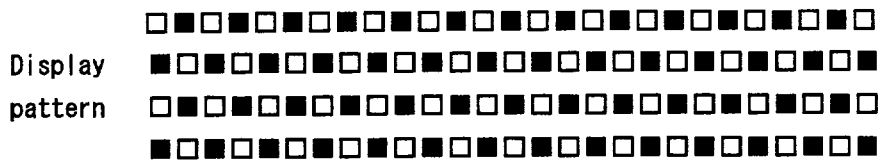

measuring circuit :

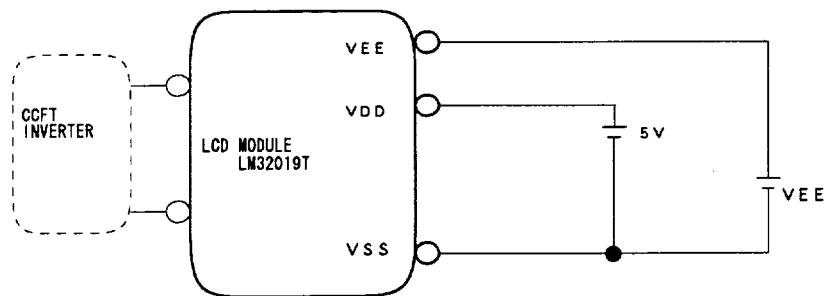

Note 4) Excluded The backlight power consumption.

Note 5) Refer to Page.14 for Characteristics of CCFT back light.

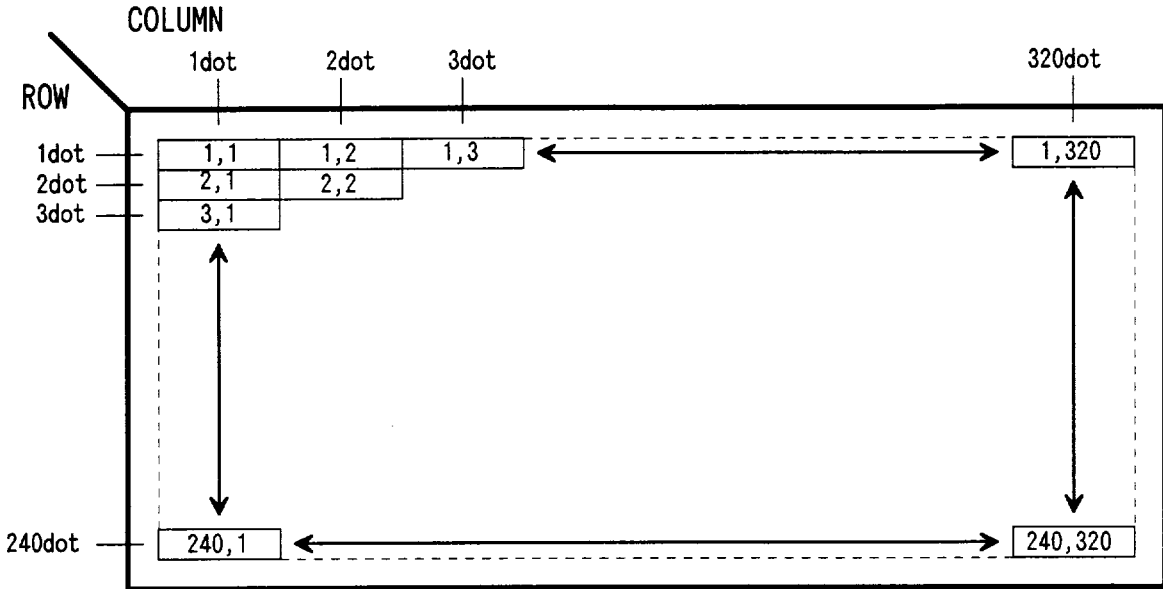

Note) 1,2 means 1st row 2nd column dot.

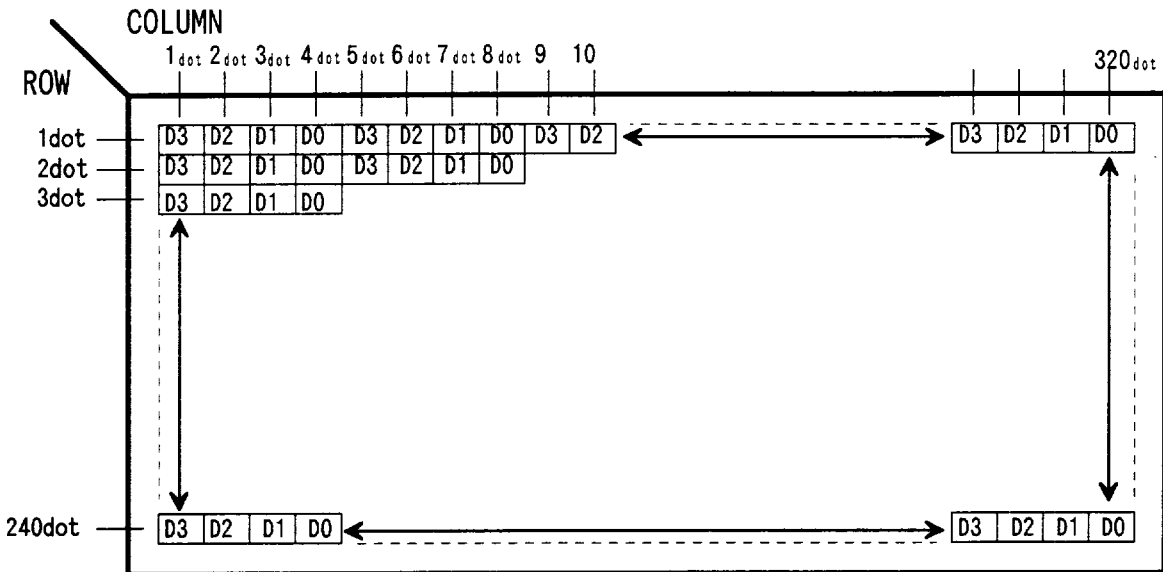

Fig.1 Dot chart of display area

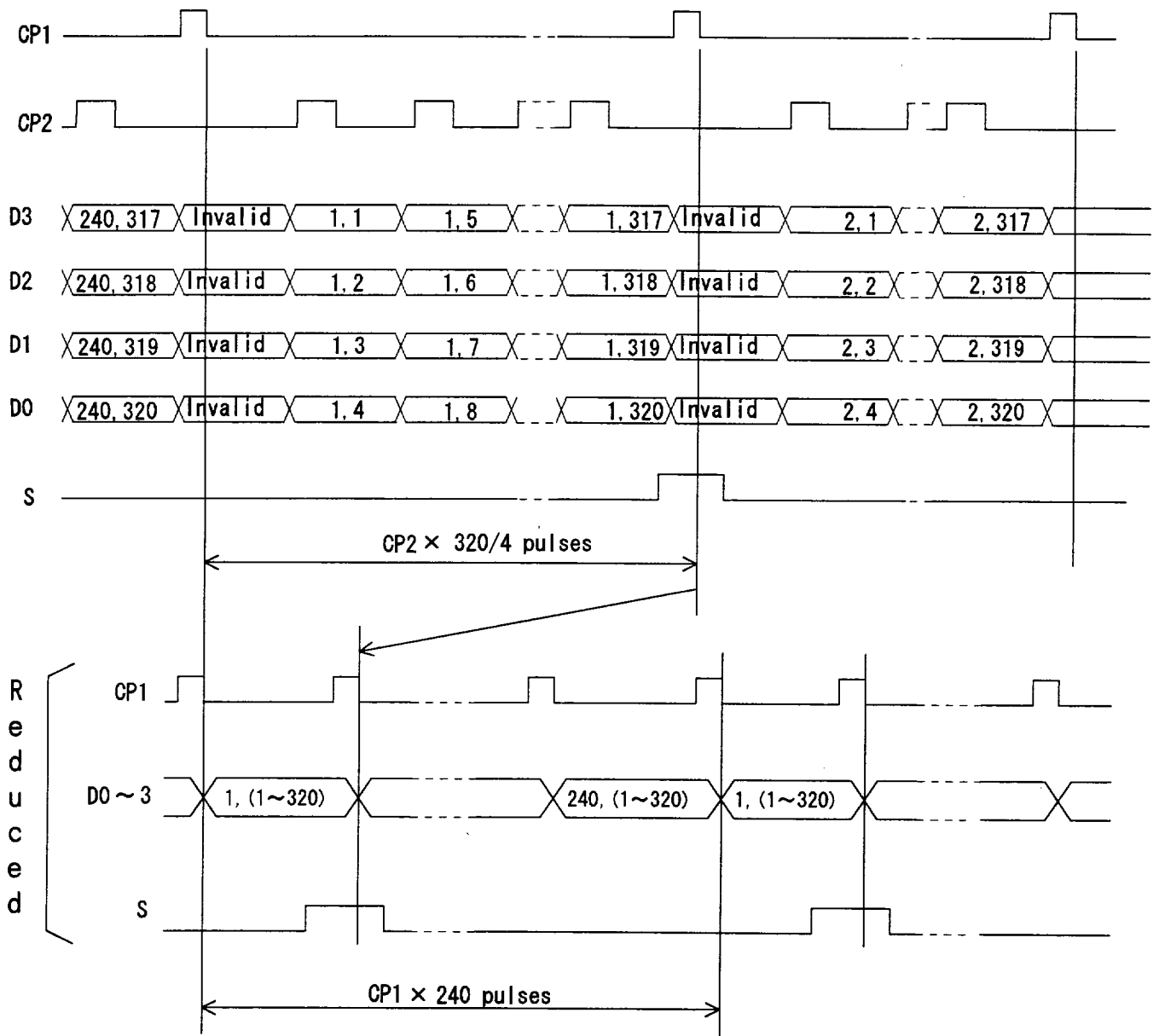
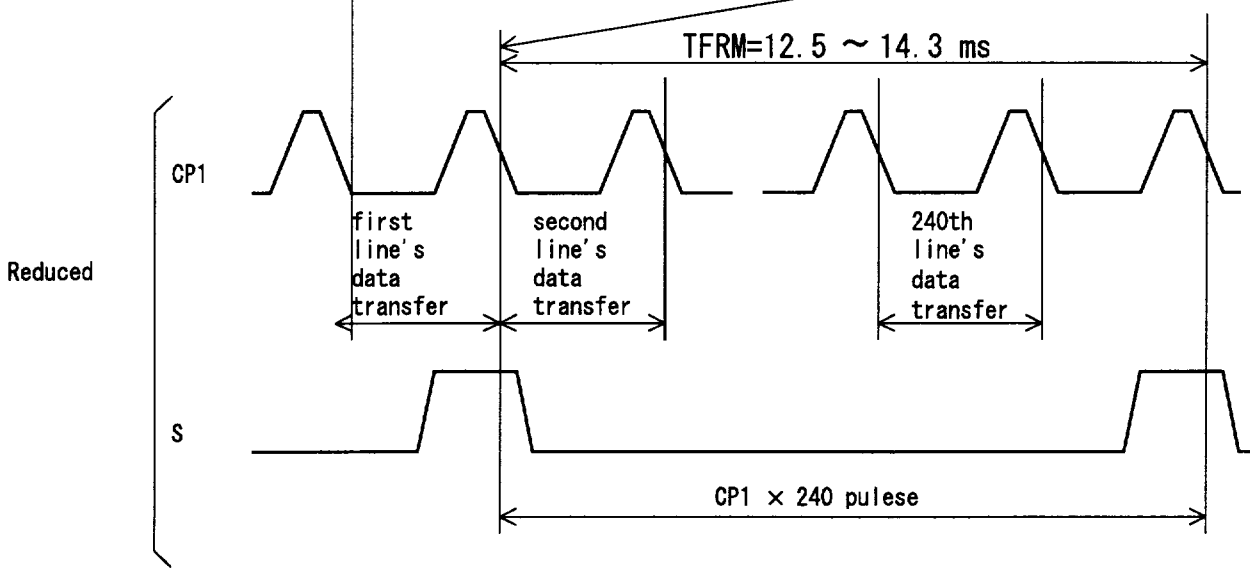
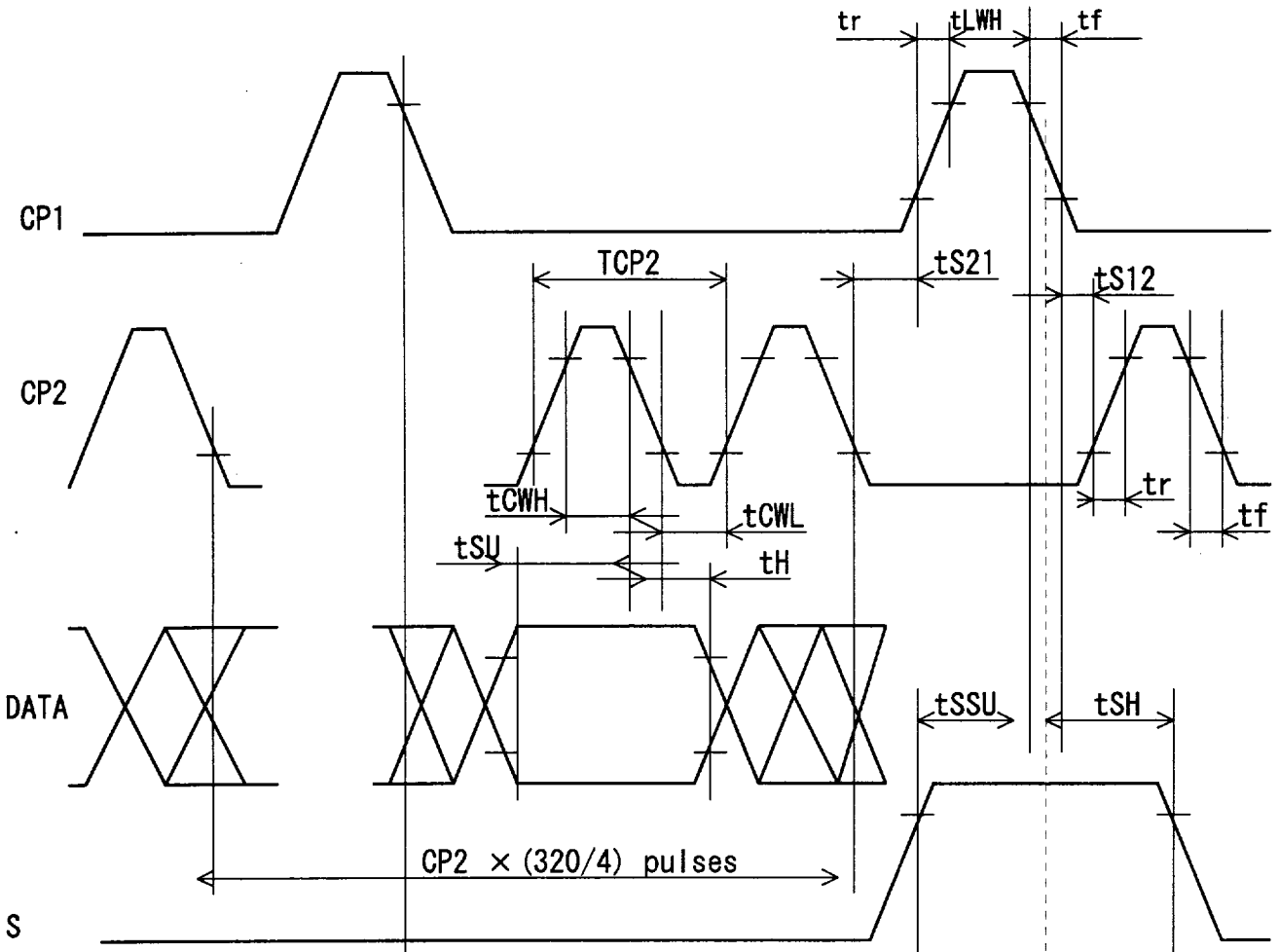

Fig. 2 Data input timing chart



$V_{IH} = 0.8V_{DD}$
 $V_{IL} = 0.2V_{DD}$

Fig. 3 Interface timing chart

Table 7 Interface timing ratings

Item	Symbol	Rating			Unit
		MIN.	TYP.	MAX.	
Frame cycle	TFRM	12.5	-	14.3	ms
CP2 clock cycle	TCP2	130	-	-	ns
"H" level clock width	tCWH	60	-	-	ns
"L" level clock width	tCWL	60	-	-	ns
"H" level latch clock width	tLWH	60	-	-	ns
Data set up time	tSU	50	-	-	ns
Data hold time	tSH	40	-	-	ns
CP2 ↑ clock allowance time from CP1 ↓	tS12	0	-	-	ns
CP1 ↑ clock allowance time from CP2 ↓	tS21	0	-	-	ns
Input signal rise/fall time (Note 1)	tr, tf	-	-	trf	ns
S Signal Data set up time	tSSU	40	-	-	ns
S Signal Data hold time	tSH	60	-	-	ns

Note 1) Owing to the characteristics of this LCD module, "shadowing" will become more eminent as frame frequency goes up. flicker will become more eminent as frame frequency goes down. So it is recommended that the module should be driven according to the specified limit.

Note 2)

$$trf=50 \text{ in case } tCT=(TCP2-tCWH-tCWL)/2 \geq 50$$

$$trf=tCT \text{ in case } tCT=(TCP2-tCWH-tCWL)/2 < 0$$

5-3 Supply voltage sequence condition

The power ON/OFF sequence shown on Fig.4 shall be followed to avoid latch-up of drive LSIs and application of DC voltage to LCD panel.

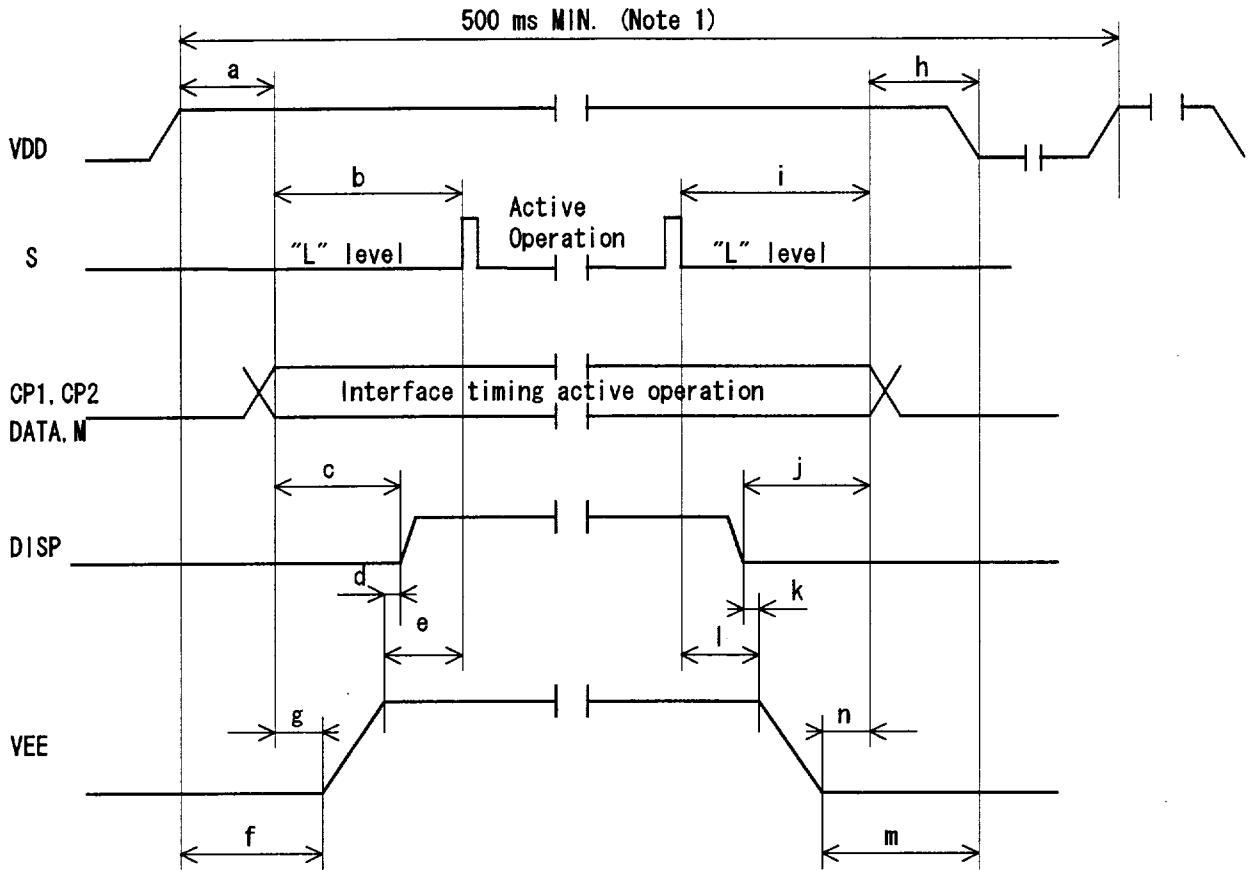

Fig. 4 Power ON/OFF sequence

Table 8 Sequence timing ratings

POWER ON		
SYMBOL	With DISP control	Without DISP control
a	0 ms MIN.	0 ms MIN. 20 ms MAX.
b	0 ms MIN.	20 ms MIN.
c	20 ms MIN.	-
d	0 ms MIN.	-
e	-	0 ms MIN.
f	0 ms MIN.	(Note 2)
g	-	20 ms MIN.

POWER OFF		
SYMBOL	With DISP control	without DISP control
h	0 ms MIN.	0 ms MIN. 20 ms MAX.
i	0 ms MIN.	20 ms MIN.
j	20 ms MIN.	-
k	0 ms MIN.	-
l	-	0 ms MIN.
m	0 ms MIN.	(Note 2)
n	-	0 ms MIN.

Note 1) Power ON/OFF cycle time. All signals and power line shall be in accordance with above sequence in case of power ON/OFF.

Note 2) VEE to be set at "VSS level"

6. Module driving method

6-1 Circuit configuration

Fig. 5 shows the block diagram of the module's circuitry.

Fig. 5 Circuit block diagram

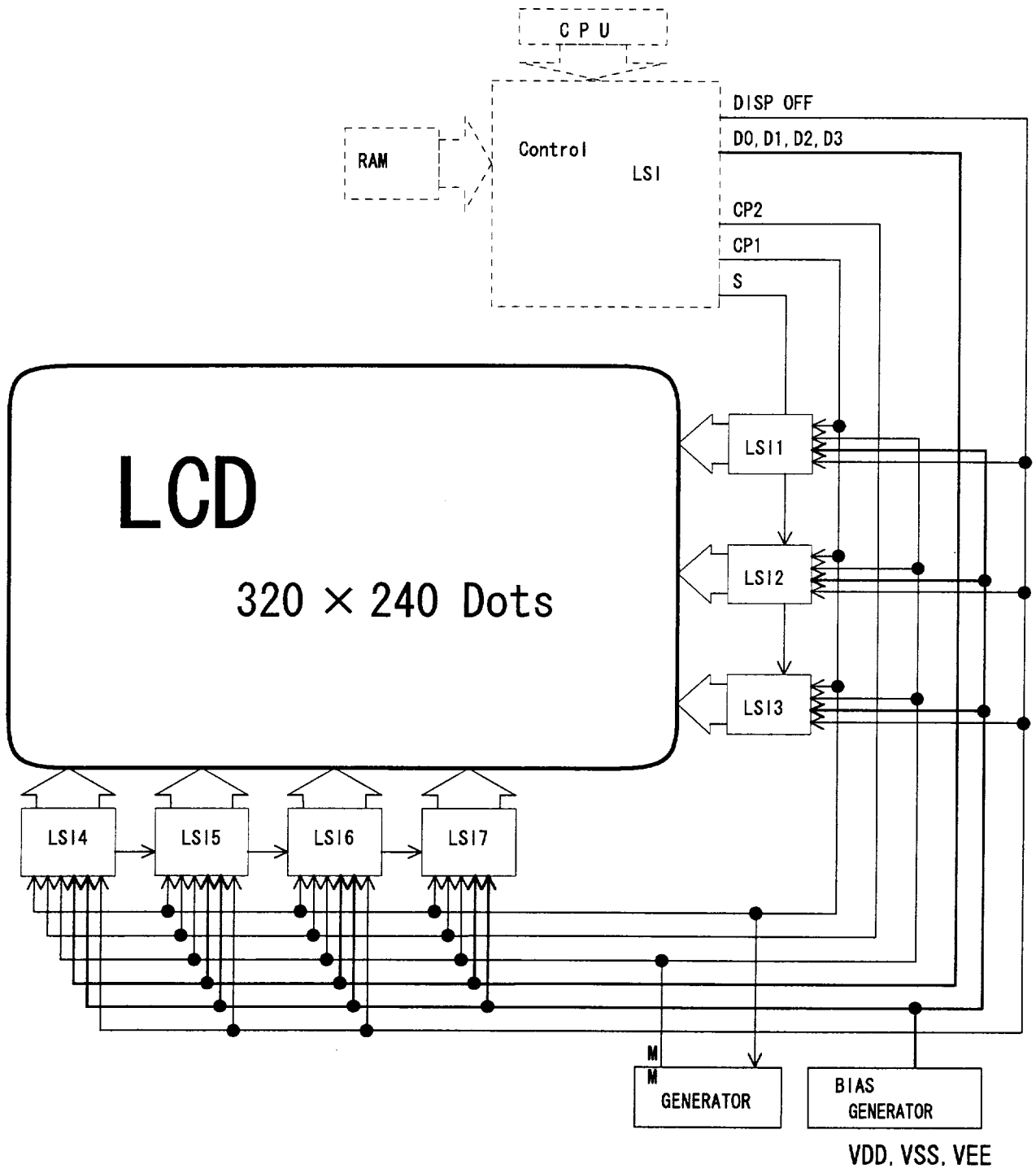

6-2 Display face configuration

The display consists of 320×240 dots as shown in Fig.1. The interface is to be driven at 1/240 duty ratio.

6-3 Input Data and Control Signal

The LCD driver is 80 bits LSI, consisting of shift registers, latch circuits and LCD driver circuits. Input data for each row (320 dot) will be sequentially transferred in the form of 4 bit parallel data through shift registers from top left of the display together with clock signal (CP2).

When input of one row (320 dots) is completed, the data will be latched in the form of parallel data corresponding to the signal electrodes by the falling edge of latch signal (CP1). Then, the corresponding drive signals will be transmitted to the 320 lines of column electrodes of the LCD panel by the LCD drive circuits.

At this time, scan start-up signal (S) has been transferred from the scan signal driver to the 1st row of scan electrodes, and the contents of the data signals are displayed on the 1st row of the display face according to the combinations of voltages applied to the scan and signal electrodes of the LCD. While the data of 1st row are being displayed, the data of 2nd row are entered. When data for 320 dots have been transferred, they will be latched by the falling edge of LP, switching the display to the 2nd row.

Such data input will be repeated up to the 240th row of each display segment, from upper row to lower rows, to complete one frame of display by time sharing method.

S generates scan signal to drive horizontal electrodes.

Since DC voltage, if applied to LCD panel, causes chemical reaction in LC materials, causing deterioration of the materials, drive wave-form shall be inverted at every display frame to prevent the generation of such DC voltage. Control Signal M plays such a role.

7. Optical characteristics

Table 9

Ta=25 °C, Frame frequency=80 Hz
1/240 DUTY, VDD=5 V, VEE-VSS=Vmax

Parameter	Symbol	Condition	MIN.	TYP.	MAX.	Unit	Remark	
Viewing angle range	θx	$Co \geq 4$ $\theta y = 0^\circ$	$\theta x \geq 0^\circ$	25	-	-	dgr.	Note 1 Note 2
			$\theta x < 0^\circ$	-	-	-25	dgr.	
	θy	$\theta x = 0^\circ$	$\theta y \geq 0^\circ$	15	-	-	dgr.	
			$\theta y < 0^\circ$	-	-	-30	dgr.	
Contrast ratio	Co	$\theta x = \theta y = 0^\circ$	8	10	-	-	Note 3	
Contrast variation	Cvar	$\theta x = \theta y = 0^\circ$	-	1.3	1.5	-	Note 1	
Response time	Rise	τr	-	350	530	ms	Note 4	
	Decay	τd	-	170	255	ms		

Note 1) Measurement method of
Contrast, Contrast variation, Viewing angle, Response time

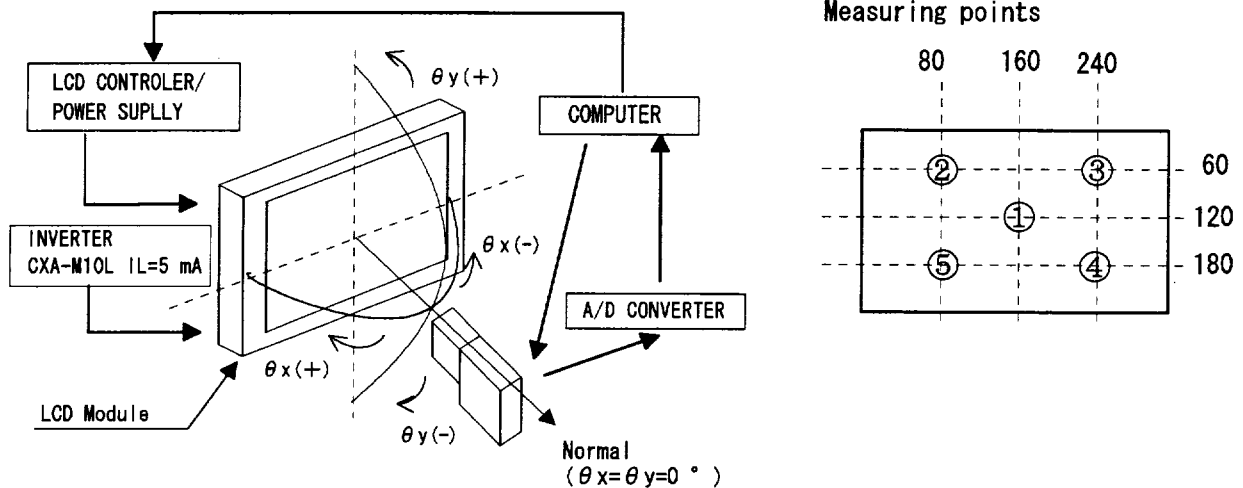

TOPCON BM-7 + quartz fiber
 Measuring spot size : $\phi 10$ mm
 Ta=25 °C
 In dark room
 Measurement shall be executed 30 min after turning on.

Note 2) The viewing angle range is defined as follows:

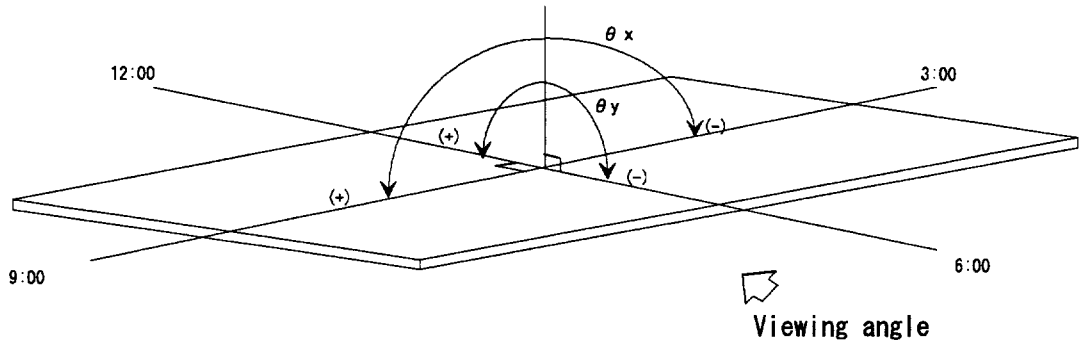

Note 3) Contrast ratio is defined as follows:

$$\text{Contrast} = \frac{\text{Luminance (brightness) all pixels "White" at } V_{\text{cmax}}}{\text{Luminance (brightness) all pixels "dark" at } V_{\text{cmax}}}$$

V_{cmax} is defined as follows:

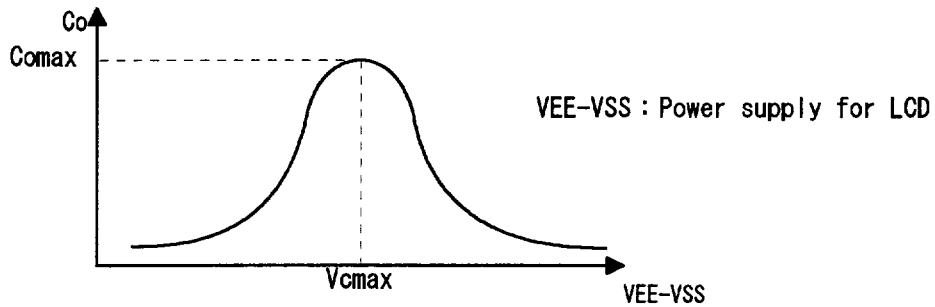

Note 4) Definition of response time

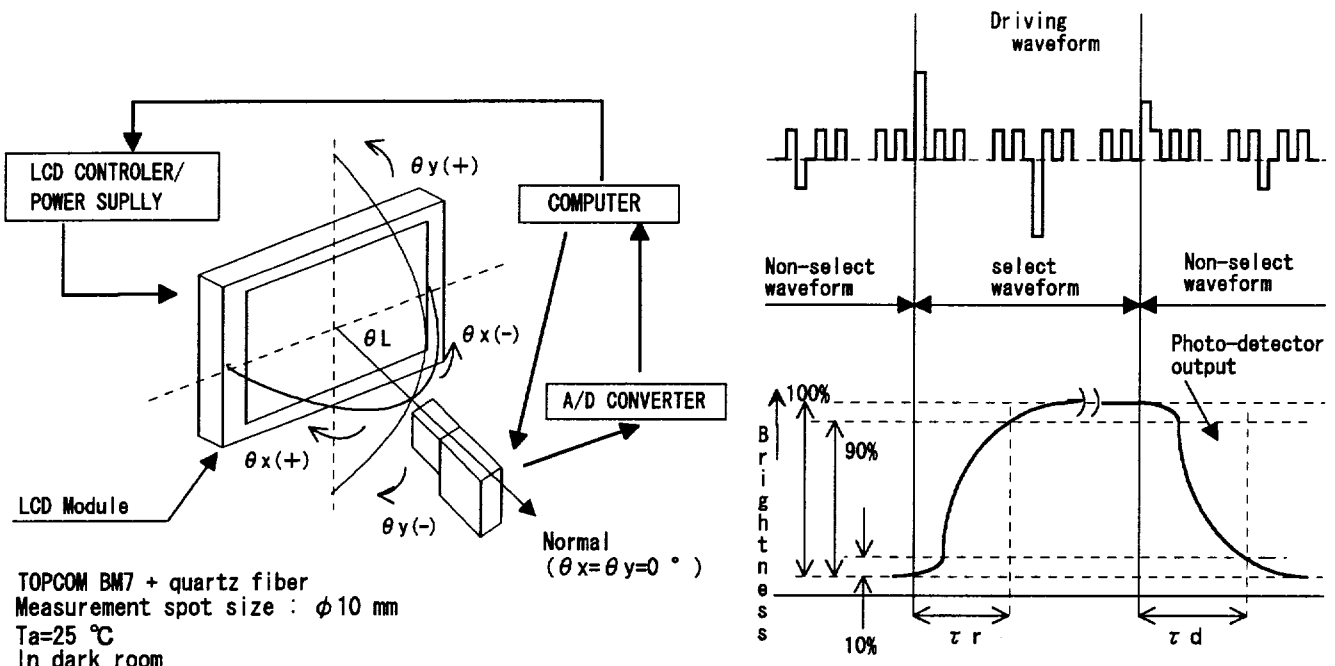

8. Characteristics of CCFT back light

The ratings are given on condition that the following conditions are satisfied.

8-1 Rating

Table 10

Parameter	Symbol	MIN.	TYP.	MAX.	Unit	Remark
Supply voltage for CCFT	VL	261	290	319	V _{rms}	
Supply current for CCFT	IL	4	5	6	mA _{rms}	
Brightness	B	50	70	-	cd/m ²	Note 1, 2
Brightness variation	B _{ver}	-	1.3	1.5		Note 1, 2
Lamp frequency	FL	20	-	60	kHz	
Start voltage	VS	-	-	900	V _{rms}	Note 2
Power consumption	WL	-	1.45	-	W	Note 2
Life time	LL	-	15,000	-	h	



Note 1) Rating are defined as the average brightness inside the viewing area specified in Fig. 6.

Note 2) Measurement conditions

CCFT inverter : CXA-M10L (TDK)

Measurement circuit current : 5 mA_{rms} fix

(circuit voltage : approximation DC 9 V)

LCD pattern : All digits WHITE, VDD=5 V, VEE-VSS=V_{max}

Ambient temperature : 25 °C

Measurement equipment: BM-7 (TOPCOM)

8-2 Operating life time

The operating life time is 15 000 hours more under the following conditions.

CCFT inverter : CXA-M10L

IFT=5 mA_{rms}

T_a=25±5°C

The operating life time is defined as having ended when any of the following conditions occur.

- When the illuminance or quantity of light has decreased to 50 % of the initial value.
- When the light of CCFT goes to flicker remarkable.

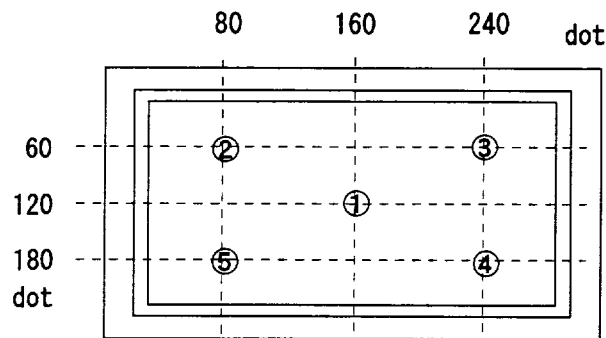

Fig. 6 Measuring point ①~⑤

9. Applicable inspection standard

The LCD module shall meet the following inspection standard

:S-U-012-01

出図	発行
ISSUE	発行
設計情報	連絡書
DRAWING INFO.	INFORMATION
No. ()	号による
新設・変更・書換	図面
NEW CHANGE REPLACE	FIGURE

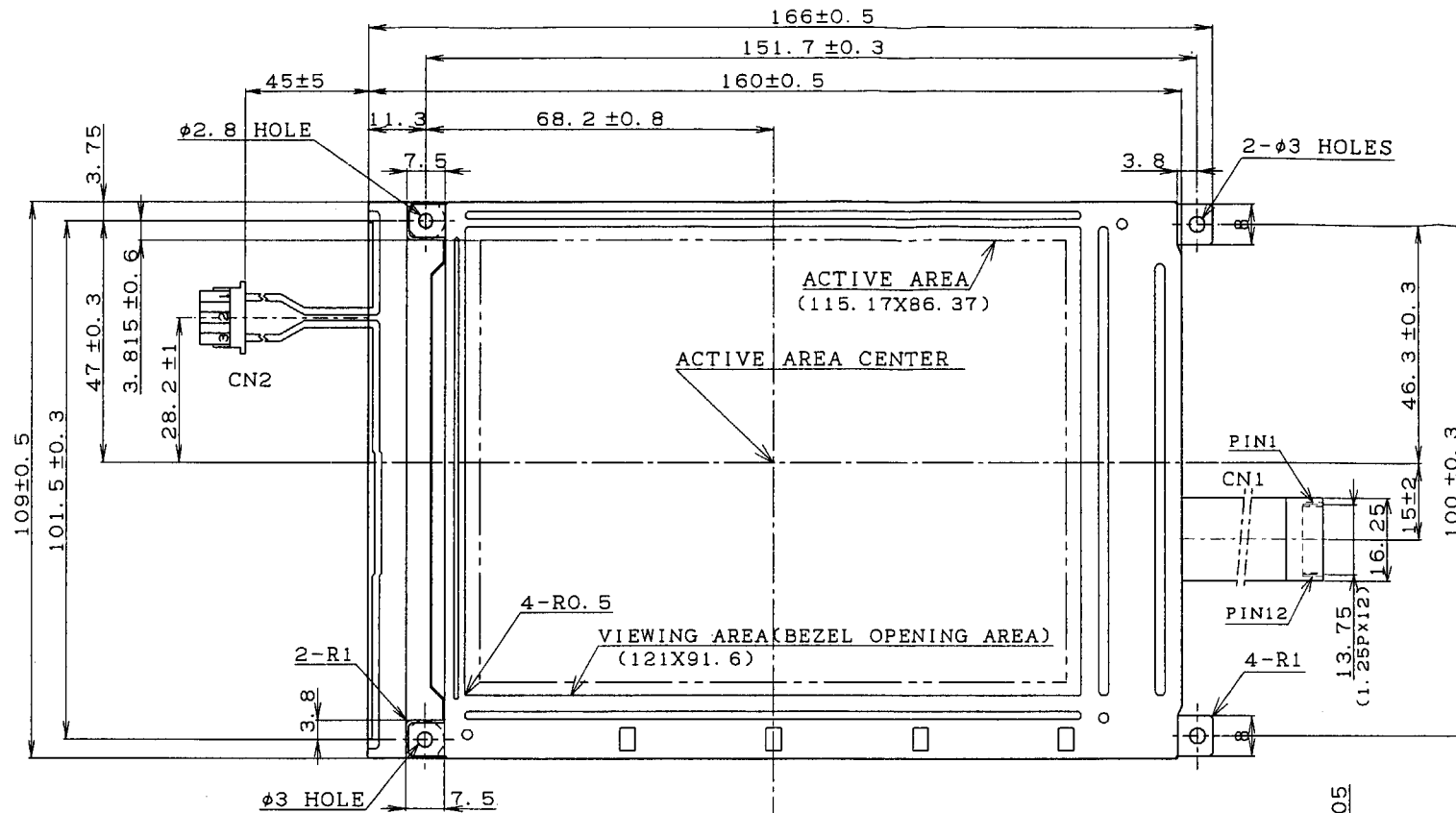

CN1 INTERFACE CABLE

Pin No	SIMBOL
1	S
2	CP1
3	CP2
4	NC
5	DISP OFF
6	DO
7	D1
8	D2
9	D3
10	VDD
11	VSS
12	VEE

CN2 CCFT CONNECTOR

Pin No	1	2	3
SIMBOL	HOT	NC	GND

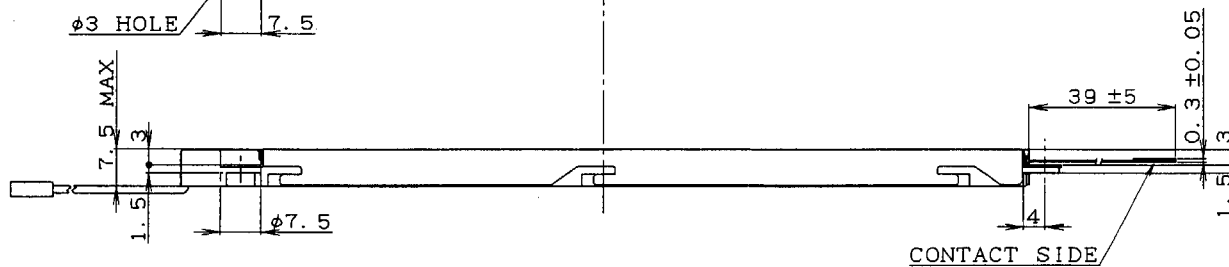
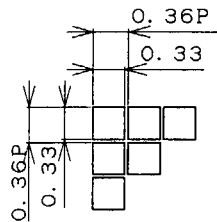

Fig. 7

- (FUJIKURA EQUIVALENT)
 5). FFC CABLE:UL2896. 1.25P
 4). CCFT CABLE:UL3579. AWG26
 3). CCFT CONNECTOR:BHR-03VS-1(JST)
 2). UNSPECIFIED TOL TO BE ±0.5
 NOTE1). UNIT IS mm.



DOTS SIZE

BEZEL/DISPLAY POSITION

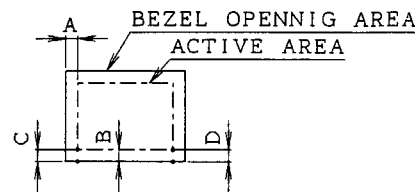

- 1) TOLERANCE X-DIRECTION A:2.9±0.8
- 2) TOLERANCE Y-DIRECTION B:2.6±0.8
- 3) OBLIQUITY OF DISPLAY AREA |C-D|<0.8

				LM32019P		名 称		LCD MODULE		
				LM32019P		NAME		OUTLINE DIMENSIONS		
DATE	訂正記事	図番No.	担当	適用機種						
MATERIAL	板厚	仕上	尺 寸	尺 寸						
				SCALE						
				1/1						
設計	専任	検回	検回	承認	アッセン		320X240 DOTS			
DESIGN	TRACE	CHECK	CHECK	APPROVE	ASSEMBLY					
				SHARP CORPORATION		部品コード				
				NARA LCD GROUP		PARTS CODE				
				発行部門		作成日付		1997. 3. 12		
				DRAWING No.		DATE				

SPECIFICATIONS ARE SUBJECT TO CHANGE WITHOUT NOTICE.

Suggested applications (if any) are for standard use; See Important Restrictions for limitations on special applications. See Limited Warranty for SHARP's product warranty. The Limited Warranty is in lieu, and exclusive of, all other warranties, express or implied. ALL EXPRESS AND IMPLIED WARRANTIES, INCLUDING THE WARRANTIES OF MERCHANTABILITY, FITNESS FOR USE AND FITNESS FOR A PARTICULAR PURPOSE, ARE SPECIFICALLY EXCLUDED. In no event will SHARP be liable, or in any way responsible, for any incidental or consequential economic or property damage.

SHARP®

NORTH AMERICA

SHARP Microelectronics of the Americas
5700 NW Pacific Rim Blvd.
Camas, WA 98607, U.S.A.
Phone: (1) 360-834-2500
Fax: (1) 360-834-8903
Fast Info: (1) 800-833-9437
www.sharpsma.com

EUROPE

SHARP Microelectronics Europe
Division of Sharp Electronics (Europe) GmbH
Sonninstrasse 3
20097 Hamburg, Germany
Phone: (49) 40-2376-2286
Fax: (49) 40-2376-2232
www.sharpsme.com

JAPAN

SHARP Corporation
Electronic Components & Devices
22-22 Nagaike-cho, Abeno-Ku
Osaka 545-8522, Japan
Phone: (81) 6-6621-1221
Fax: (81) 6117-725300/6117-725301
www.sharp-world.com

TAIWAN

SHARP Electronic Components
(Taiwan) Corporation
8F-A, No. 16, Sec. 4, Nanking E. Rd.
Taipei, Taiwan, Republic of China
Phone: (886) 2-2577-7341
Fax: (886) 2-2577-7326/2-2577-7328

SINGAPORE

SHARP Electronics (Singapore) PTE., Ltd.
438A, Alexandra Road, #05-01/02
Alexandra Technopark,
Singapore 119967
Phone: (65) 271-3566
Fax: (65) 271-3855

KOREA

SHARP Electronic Components
(Korea) Corporation
RM 501 Geosung B/D, 541
Dohwa-dong, Mapo-ku
Seoul 121-701, Korea
Phone: (82) 2-711-5813 ~ 8
Fax: (82) 2-711-5819

CHINA

SHARP Microelectronics of China
(Shanghai) Co., Ltd.
28 Xin Jin Qiao Road King Tower 16F
Pudong Shanghai, 201206 P.R. China
Phone: (86) 21-5854-7710/21-5834-6056
Fax: (86) 21-5854-4340/21-5834-6057

Head Office:

No. 360, Bashen Road,
Xin Development Bldg. 22
Waigaoqiao Free Trade Zone Shanghai
200131 P.R. China
Email: smc@china.global.sharp.co.jp

HONG KONG

SHARP-ROXY (Hong Kong) Ltd.
3rd Business Division,
17/F, Admiralty Centre, Tower 1
18 Harcourt Road, Hong Kong
Phone: (852) 28229311
Fax: (852) 28660779
www.sharp.com.hk

Shenzhen Representative Office:

Room 13B1, Tower C,
Electronics Science & Technology Building
Shen Nan Zhong Road
Shenzhen, P.R. China
Phone: (86) 755-3273731
Fax: (86) 755-3273735