



## LM165/LM365, LM166/LM366, LM167/LM367, LM168/LM368 MOS sense amplifiers (MOS to TTL converters)

### general description

This is a new series of hex sense amplifiers. The LM165/LM365 and LM166/LM366 have TRI-STATE outputs. The LM167/LM367 and LM168/LM368 have both TRI-STATE inputs and outputs. High impedance states are controlled by an enable input.

unconnected. It can be set from  $100\mu\text{A}$  to  $350\mu\text{A}$  by connecting a resistor from the pin to ground, and set above  $350\mu\text{A}$  by connecting a resistor from the pin to the positive supply.

The current threshold at which the outputs change state is determined by the current at the programming pin. The current threshold is  $100\mu\text{A}$  with the programming pin grounded and  $350\mu\text{A}$  with the pin

The outputs are high current drivers capable of sinking 50 mA in the low state and sourcing 5.0 mA in the high state. The circuits feature high speed direct MOS sense capability with high impedance states to allow use of a common bus line.

### connection diagram

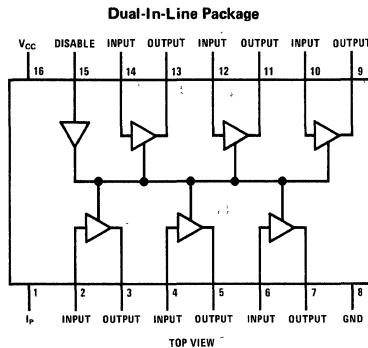

### truth tables

LM165/LM365		
$I_{IN}$	$D_{IS}$	OUT
X	H	Hi-z
$>I_t$	L	H
$<I_t$	L	L

LM166/LM366		
$I_{IN}$	$D_{IS}$	OUT
X	H	Hi-z
$>I_t$	L	L
$<I_t$	L	H

LM167/LM367		
$I_{IN}$	$D_{IS}$	OUT
X	H	Hi-z
$>I_t$	L	L
$<I_t$	L	H

LM168/LM368		
$I_{IN}$	$D_{IS}$	OUT
X	H	Hi-z
$>I_t$	L	H
$<I_t$	L	L

**absolute maximum ratings** (Note 1)

Supply Voltage	7.0V
Input Voltage	5.5V
Output Voltage	5.5V
Storage Temperature Range	-65°C to +150°C
Lead Temperature (Soldering, 10 seconds)	300°C

**operating conditions**

	MIN	MAX	UNITS
Supply Voltage (V <sub>CC</sub> )			
LM165, LM166, LM167, LM168	4.5	5.5	V
LM365, LM366, LM367, LM368	4.75	5.25	V
Temperature (T <sub>A</sub> )			
LM165, LM166, LM167, LM168	-55	+125	°C
LM365, LM366, LM367, LM368	0	+70	°C

**electrical characteristics** (Notes 2 and 3)

PARAMETER	CONDITIONS	MIN	TYP	MAX	UNITS
Logical "1" Input Voltage (V <sub>IH</sub> )	V <sub>CC</sub> = Min	2.0			V
Logical "1" Input Current Disable (I <sub>IH</sub> )	V <sub>CC</sub> = Max, V <sub>IN</sub> = 2.4V			40	μA
Input Threshold (I <sub>t</sub> )	I <sub>p</sub> = 0.0μA		400		μA
Logical "0" Input Voltage (V <sub>IL</sub> )	V <sub>CC</sub> = Min			0.8	V
Logical "0" Input Current (I <sub>IL</sub> )	V <sub>CC</sub> = Max, V <sub>IN</sub> = 0.4V			-1.6	mA
Input Clamp Voltage (V <sub>CO</sub> )	V <sub>CC</sub> = Min, I <sub>OUT</sub> = -12 mA		1.0		V
Logical "1" Output Voltage (V <sub>OH</sub> )	V <sub>CC</sub> = Min, I <sub>OUT</sub> = -5.0 mA	2.4			V
Output Short Circuit Current (I <sub>OS</sub> ) (Note 4)	V <sub>CC</sub> = Max, V <sub>OUT</sub> = 0.0V	-20		-100	mA
Logical "0" Output Voltage (V <sub>OL</sub> )	V <sub>CC</sub> = Min, I <sub>OUT</sub> = 50 mA		0.3		V
Supply Current (I <sub>CC</sub> )					
LM165/LM365, LM166/LM366	V <sub>CC</sub> = Max		70		mA
LM167/LM367, LM168/LM368	V <sub>CC</sub> = Max		80		mA
Input and Output Disable Current (I <sub>DIS</sub> )	V <sub>CC</sub> = Max, 0.4V ≤ V ≤ 2.4V		±5.0		μA

**switching characteristics** T<sub>A</sub> = 25°C

PARAMETER	CONDITIONS	MIN	TYP	MAX	UNITS
Propagation Delay Time, Low to High Level (t <sub>pdLH</sub> )	C <sub>L</sub> = 50 pF, R <sub>L</sub> = 80Ω				
LM165/LM365, LM168/LM368			12		ns
LM166/LM366, LM167/LM367			15		ns
Propagation Delay Time, High to Low Level (t <sub>pdHL</sub> )	C <sub>L</sub> = 50 pF, R <sub>L</sub> = 80Ω				
LM165/LM365			10		ns
LM166/LM366, LM167/LM367			15		ns
LM168/LM368			12		ns

**note 1:** "Absolute Maximum Ratings" are those values beyond which the safety of the device cannot be guaranteed. Except for "Operating Temperature Range" they are not meant to imply that the devices should be operated at these limits. The table of "Electrical Characteristics" provides conditions for actual device operation.

**note 2:** Unless otherwise specified min/max limits apply across the -55°C to +125°C temperature range for the LM165, LM166, LM167, LM168 and across the 0°C to +70°C range for the LM365, LM366, LM367, LM368. All typicals are given for V<sub>CC</sub> = 7.0V and T<sub>A</sub> = 25°C.

**note 3:** All currents into device pins shown as positive, out of device pins as negative. All voltages referenced to ground unless otherwise noted. All values shown as max or min on absolute value basis.

**note 4:** Only one output at a time should be shorted.