

## LM3820 AM Radio System

### General Description

The LM3820 is a 3-stage AM radio IC consisting of an RF amplifier, oscillator, mixer, IF amplifier, AGC detector, and zener regulator.

The device was originally designed for use in slug-tuned auto radio applications, but is also suitable for capacitor-tuned portable radios.

The LM3820 is an improved replacement for the LM1820.

### Features

- Input protection diodes
- Good control on sensitivity
- Improved S/N and tweet
- Versatile building-block approach
- Gain-controlled RF stage
- Cascode IF amplifier
- Regulated supply
- Pin compatible with LM1820

### Connection Diagram

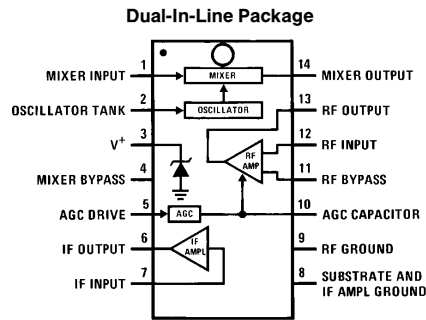

TL/H/7967-1

Order Number LM3820N  
See NS Package Number N14A

### Circuit Schematic

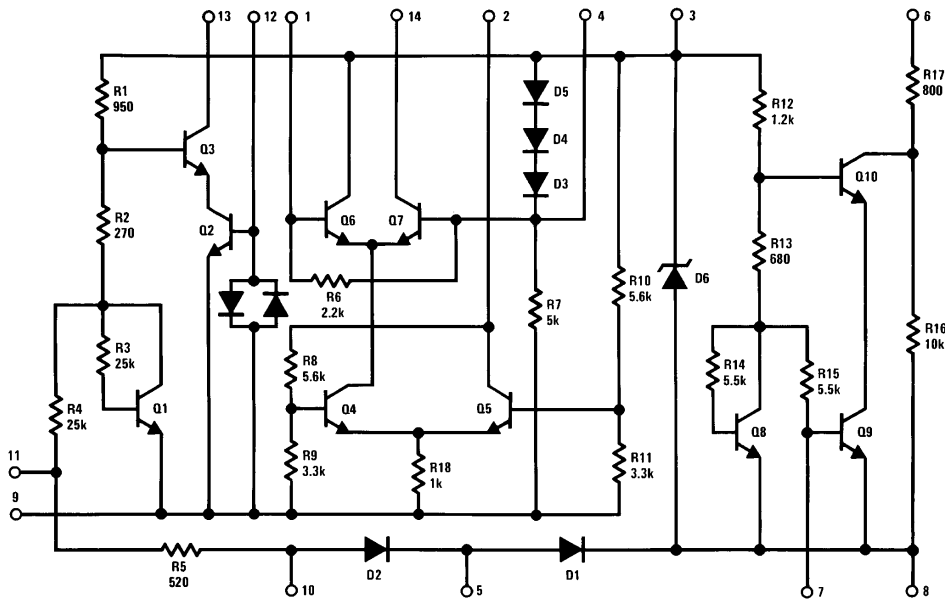

TL/H/7967-2

## Absolute Maximum Ratings

If Military/Aerospace specified devices are required, please contact the National Semiconductor Sales Office/Distributors for availability and specifications.

Power Dissipation (Note 1) 1200 mW  
Supply Voltage 16V

Current into Supply Terminal (Pin 3) 35 mA  
Operating Temperature Range -25°C to +85°C  
Storage Temperature Range -65°C to +150°C  
Lead Temperature (Soldering, 10 sec.) 260°C

## Electrical Characteristics (Figure 1, $T_A = 25^\circ\text{C}$ , $V_S = 6\text{V}$ unless noted)

Symbol	Parameter	Conditions	Min	Typ	Max	Units
$I_S$	Supply Current	No RF Input	12	18	24	mA
$V_Z$	Internal Zener Voltage		7.0	7.5	8.0	V
	Input Sensitivity	$f = 1\text{ MHz}$ , 30% Mod 400 Hz Measure RF Input Level for 10 mV Audio Output with Tuning Peaked	15	35	70	$\mu\text{V}$
	Signal to Noise Ratio	$f = 1\text{ MHz}$ , 30% Mod 1 kHz (S + N)/N at Audio Output with 100 $\mu\text{V}$ RF Input	22	28	—	dB
	Overload Distortion	$f = 1\text{ MHz}$ , 90% Mod 1 kHz THD at Audio Output with 30 mV RF Input	—	6	10	%

Note 1: Above  $T_A = 25^\circ\text{C}$ , derate based on  $T_{J(\text{Max})} = 150^\circ\text{C}$  and  $\theta_{JA} = 100^\circ\text{C/W}$ .

## Typical Applications

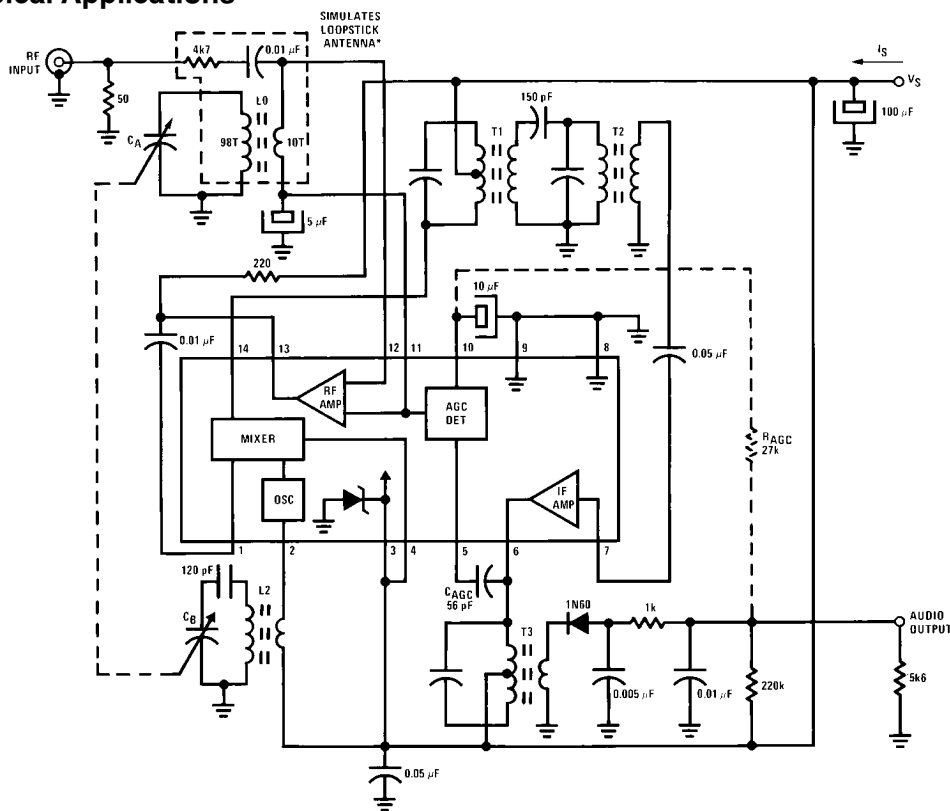

\*100  $\mu\text{V}$  RF INPUT is equivalent to approx. 1 mV/meter field strength. See Applications Information for coil specifications.

TL/H/7967-3

FIGURE 1. Capacitor-Tuned Test Fixture

## Applications Information

The circuit shown in *Figure 1* is recommended as a starting point for portable radio designs. Loopstick antenna L1 is used in place of L0, and the RF amplifier is used with a resistor load to drive the mixer. A double tuned circuit at the output of the mixer provides selectivity, while the remainder of the gain is provided by the IF section, which is matched to the diode through a unity turns ratio transformer.  $R_{AGC}$  may be used in place of  $C_{AGC}$  to bypass the internal AGC detector and provide more recovered audio.

An AM automobile radio design is shown in *Figure 2*. Tuning of both the input and the output of the RF amplifier and the mixer is accomplished with variable inductors. Better selectivity is obtained through the use of double tuned interstage transformers. Input circuits are inductively tuned to prevent microphonics and provide a linear tuning motion to facilitate push-button operation.

Coil specifications for *Figure 1* are as follows:

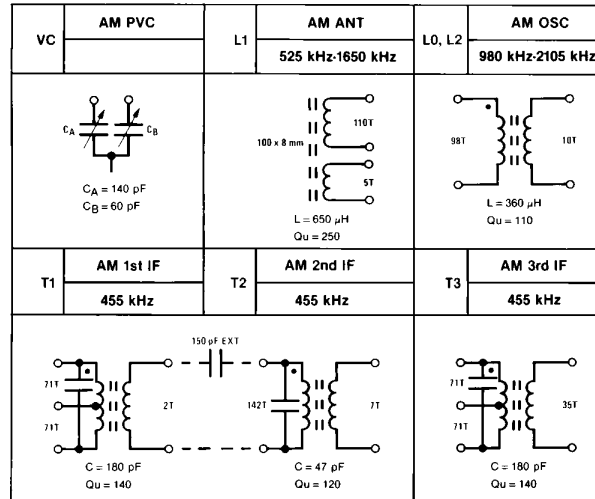

TL/H/7967-4

PCB Layout for *Figure 1* Circuit

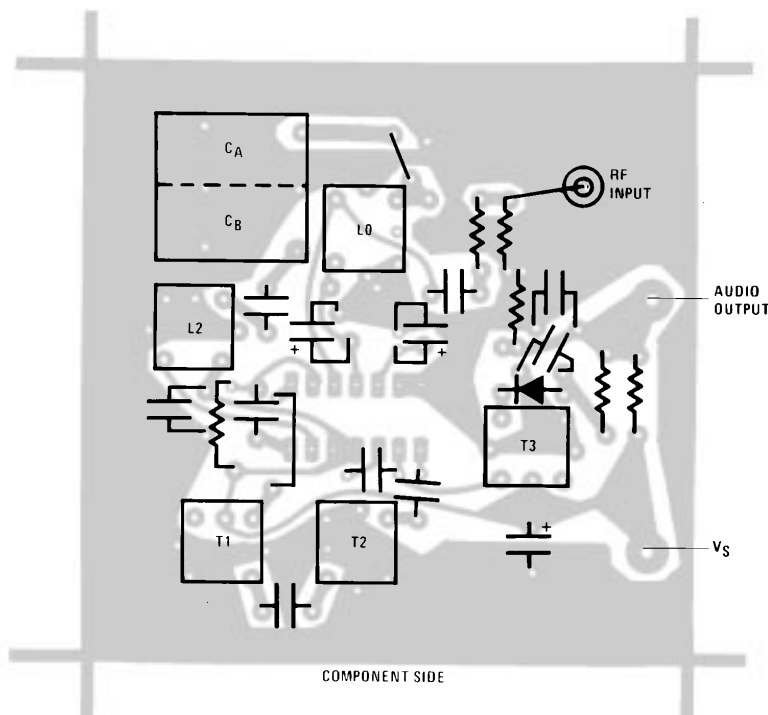

TL/H/7967-5

## Applications Information (Continued)

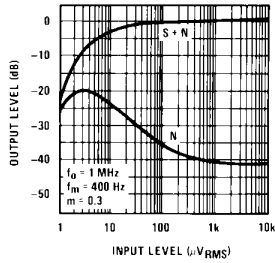
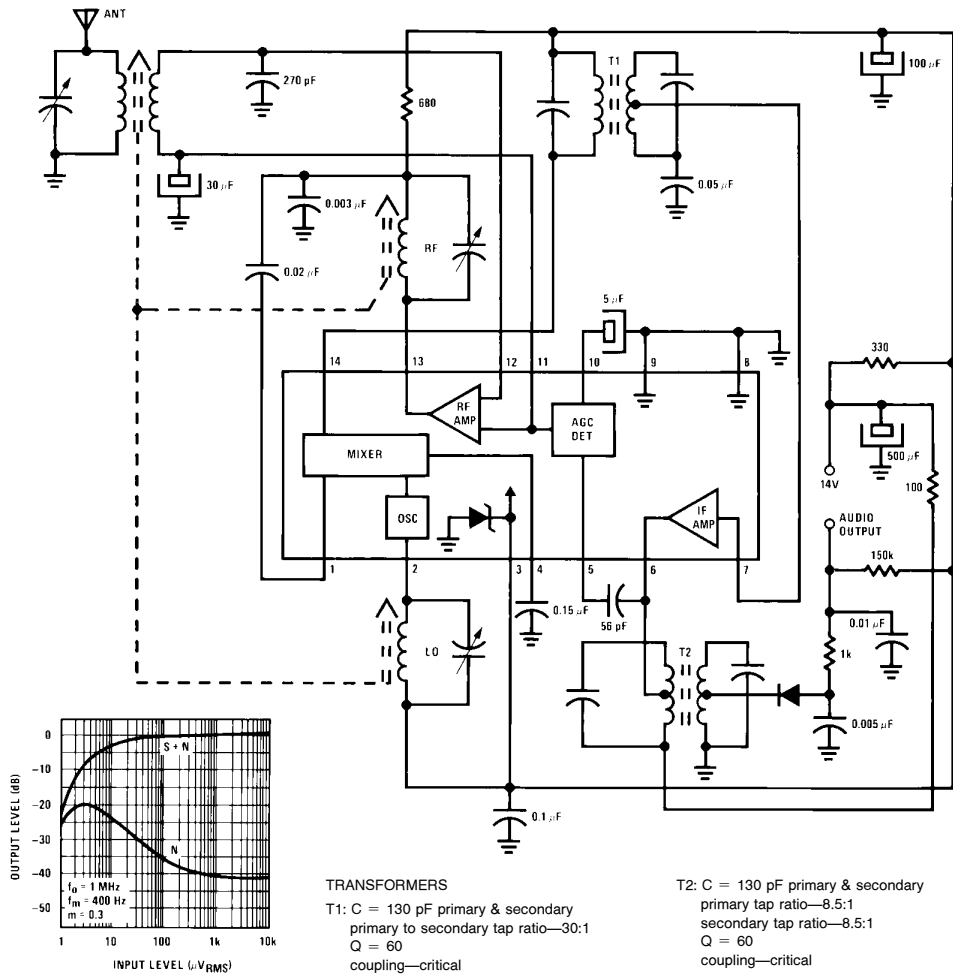

FIGURE 2. Slug-Tuned Auto Radio

TL/H/7967-6

Schematic Reference	Toko* Part Number
L0, L2	RWO-6A6255
T1	RRC-3A6426N
T2	RRC-3A6427A
T3	RZC-1A6425A

\*Toko America  
1250 Feehanville Drive  
Mount Prospect, IL 60056  
(312) 297-0070

FIGURE 3. Representative Part Numbers  
for the Coils of Figure 1



**Physical Dimensions** inches (millimeters)

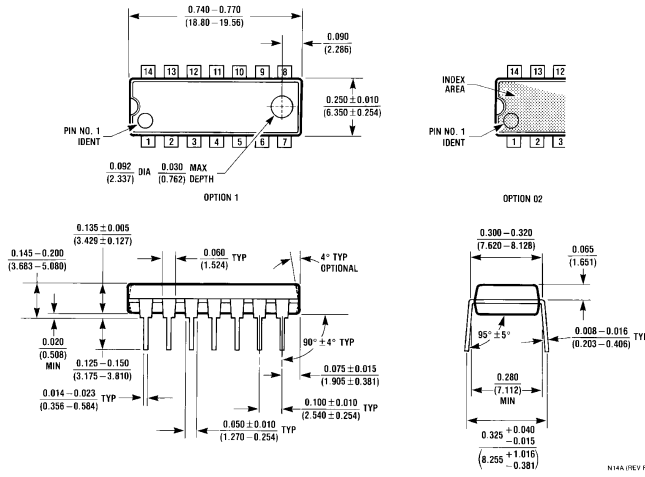

**Molded Dual-In-Line Package (N)**  
**Order Number LM3820N**  
**NS Package Number N14A**

**LIFE SUPPORT POLICY**

NATIONAL'S PRODUCTS ARE NOT AUTHORIZED FOR USE AS CRITICAL COMPONENTS IN LIFE SUPPORT DEVICES OR SYSTEMS WITHOUT THE EXPRESS WRITTEN APPROVAL OF THE PRESIDENT OF NATIONAL SEMICONDUCTOR CORPORATION. As used herein:

1. Life support devices or systems are devices or systems which, (a) are intended for surgical implant into the body, or (b) support or sustain life, and whose failure to perform, when properly used in accordance with instructions for use provided in the labeling, can be reasonably expected to result in a significant injury to the user.
2. A critical component is any component of a life support device or system whose failure to perform can be reasonably expected to cause the failure of the life support device or system, or to affect its safety or effectiveness.



**National Semiconductor Corporation**  
 1111 West Bardin Road  
 Arlington, TX 76017  
 Tel: 1(800) 272-9959  
 Fax: 1(800) 737-7018

**National Semiconductor Europe**  
 Fax: (+49) 0-180-530 85 86  
 Email: cnjwge@tevm2.nsc.com  
 Deutsch Tel: (+49) 0-180-530 85 85  
 English Tel: (+49) 0-180-532 78 32  
 Français Tel: (+49) 0-180-532 93 58  
 Italiano Tel: (+49) 0-180-534 16 80

**National Semiconductor Hong Kong Ltd.**  
 19th Floor, Straight Block,  
 Ocean Centre, 5 Canton Rd.  
 Tsimshatsui, Kowloon  
 Hong Kong  
 Tel: (852) 2737-1600  
 Fax: (852) 2736-9960

**National Semiconductor Japan Ltd.**  
 Tel: 81-043-299-2309  
 Fax: 81-043-299-2408

National does not assume any responsibility for use of any circuitry described, no circuit patent licenses are implied and National reserves the right at any time without notice to change said circuitry and specifications.