

Ordering number: EN3937



No. 3937

Monolithic Linear IC

LA3860

Japanese Television Sound Demodulator
with Built-in FM Stereo Decoder

OVERVIEW

The LA3860 is a mono, stereo and bilingual television sound demodulator IC with built-in FM stereo decoder for use in Japanese home-stereo tuners. The TV and FM MPXs share a single ceramic resonator to reduce the external component count.

The LA3860 has automatic stereo (982.5 Hz) and bilingual (922.5 Hz) TV Q-signal detectors, and stereo TV/FM and bilingual TV indicator LED drivers. It has controls for selecting TV, FM and VCO-STOP (AM) modes and output muting, and for main-channel, sub-channel or dual output in bilingual TV mode. In VCO-STOP mode, both the TV and FM PLLs are halted. In bilingual TV mode, output selection is active while the bilingual Q-signal is detected.

The LA3860 has adjustment-free digital (TV) and analog (FM) PLLs, internal 75 μs TV (or AM in VCO-STOP mode) and external 50 μs FM deemphasis, and separate TV and FM output amplifiers. It also has Q-signal and subchannel bandpass, and TV-FAX band-elimination filters. The subchannel demodulator functions by pulse-count detection.

The LA3860 operates from a 12 V supply and is available in 30-pin DIPs.

FEATURES

- TV/FM PLLs and digital circuits use a single ceramic resonator to reduce component count.
- Adjustment-free TV and FM PLLs
- Complete demodulator requires only three adjustments.
- Independent TV and FM channel separation adjustments
- High Q-signal detector FM crosstalk rejection
- TV/FM, main-channel and subchannel switching can be controlled by microprocessor.
- Japanese TV-FAX (4.5f_H) band-elimination filter
- Low switching noise when changing modes
- 12 V supply
- 30-pin DIP

PINOUT

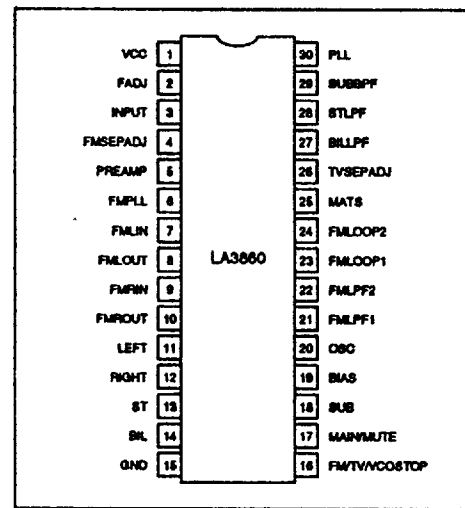

PACKAGE DIMENSIONS

Unit: mm

3061-DIP30SN

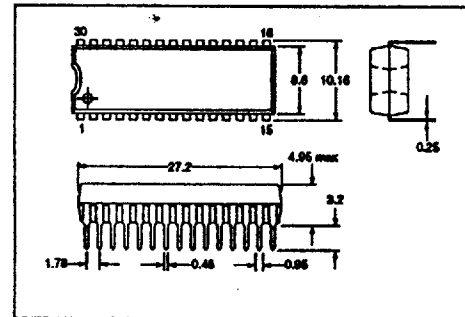

SANYO Electric Co., Ltd. Semiconductor Division
Natsume Bldg., 18-6, 2-chome, Yushima, Bunkyo-ku, Tokyo 113, Japan

LA3860

BLOCK DIAGRAM

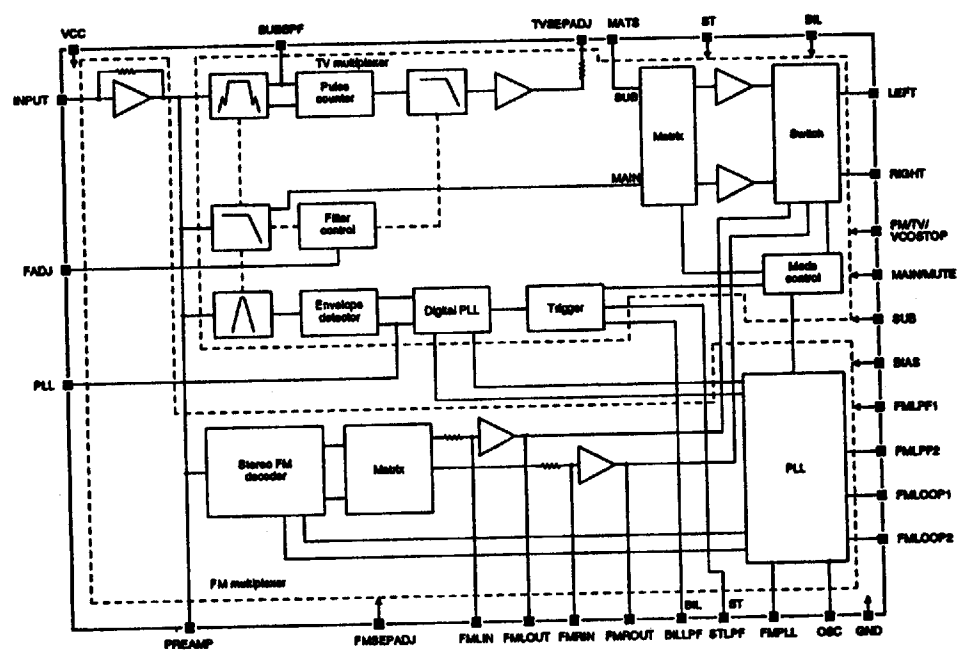

PIN DESCRIPTION

Number	Name	Description
1	VCC	12 V supply
2	FADJ	LPF and BPF bandwidth adjust. Nominal voltage is 1 V.
3	INPUT	FM, TV and AM signal preamplifier inverting input. Nominal voltage is 5.2 V.
4	FMSEPADJ	FM separation adjust. Nominal voltage is 5.2 V.
5	PREAMP	Preamplifier output. Nominal voltage is 4.5 V.
6	FMPLL	FM PLL input. Nominal voltage is 3 V.
7	FMLIN	FM left-channel output amplifier inverting input. Nominal voltage is 5.2 V.
8	FMLOUT	FM left-channel output amplifier output. Nominal voltage is 5.2 V.
9	FMRIN	FM right-channel output amplifier inverting input. Nominal voltage is 5.2 V.
10	FMROUT	FM right-channel output amplifier output. Nominal voltage is 5.2 V.
11	LEFT	Left-channel AF output. Nominal voltage is 5.2 V.
12	RIGHT	Right-channel AF output. Nominal voltage is 5.2 V.
13	ST	Active-LOW stereo TV and FM indicator output. Open-collector output
14	BL	Active-LOW bilingual indicator output. Open-collector output
15	GND	Ground
16	FM/TV/VCOSTOP	FM, TV and VCOSTOP (AM) mode control input

LA3860

Number	Name	Description
17	MAINMUTE	Active-LOW bilingual main-channel select and output mute input
18	SUB	Active-LOW bilingual subchannel select input
19	BIAS	TV main-channel deemphasis bias capacitor connection. Nominal voltage is 4.8 V.
20	OSC	456 kHz ceramic resonator (Murata CSE456F26) connection. Nominal voltage is 3.4 V.
21	FMLPF1	FM pilot synchronous detector LPF connections. Nominal voltages are 3 V.
22	FMLPF2	
23	FMLOOP1	FM pilot loop filter connections. Nominal voltages are 3 V.
24	FMLOOP2	
25	MATS	TV matrix subchannel input. Nominal voltage is 4.5 V.
26	TVSEPADJ	TV separation adjust. Nominal voltage is 4.2 V.
27	BLLPF	TV bilingual Q-signal (92.5 Hz) synchronous detector LPF capacitor connection. Nominal voltage is 3.9 V.
28	STLPF	TV stereo Q-signal (98.25 Hz) synchronous detector LPF capacitor connection. Nominal voltage is 3.9 V.
29	SUBBPF	TV subchannel BPF capacitor connection. Nominal voltage is 3.1 V.
30	PLL	TV digital PLL capacitor connection. Nominal voltage is 4 V.

SPECIFICATIONS

Absolute Maximum Ratings

Parameter	Symbol	Rating	Unit
Supply voltage	V _{CC}	14	V
ST and BL input voltage	V _{I1}	14	V
RMTWCOSTOP, MAINMUTE and SUB input voltage	V _{I2}	V _{CC}	V
ST and BL input current	I _I	30	mA
Power dissipation	P _D	1000	mW
Operating temperature range	T _{OP}	-20 to 70	°C
Storage temperature range	T _{STG}	-40 to 180	°C

Recommended Operating Conditions

T_a = 25 °C

Parameter	Symbol	Rating	Unit
Supply voltage	V _{CC}	12	V
Supply voltage range	V _{CC}	11 to 13	V
INPUT TV mono signal input voltage	V _{I TV}	80	mV
INPUT FM mono signal input voltage	V _{I FM}	240	mV

LA3860

Electrical Characteristics

The input conditions for each operating mode are as follows.

- TV mono—80 mV, 1 kHz signal with 100% modulation
- TV stereo—1 kHz, L + R composite signal with 100% modulation and 55.069 kHz Q-signal with 982.5 Hz, 60% modulation
- Bilingual—1 kHz, main-channel composite signal with 100% modulation and 55.069 kHz Q-signal with 922.5 Hz, 60% modulation
- FM mono—240 mV, 1 kHz signal with 100% modulation
- FM stereo—1 kHz, L + R composite signal with 90% modulation and 19 kHz pilot with 10% modulation

TV mode

$V_{CC} = 12\text{ V}$, $T_c = 25\text{ }^\circ\text{C}$, FM/TV/VCOSTOP is 5 V.

Parameter	Symbol	Condition	Rating			Unit
			min	typ	max	
Quiescent supply current	I_{CCQ}		35	60	70	mA
FM to TV mode switch voltage	V_{FT}		-	1.0	-	V
TV to VCOSTOP (AM) mode switch voltage	V_{VCO}		-	7.8	-	V
Bilingual main-channel switch OFF voltage	V_{MMR}		-	1.5	-	V
Bilingual sub-channel switch OFF voltage	V_{MUS}		-	1.5	-	V
Mute ON input voltage	V_{MUTE}		-	7.2	-	V
TV (AM) output voltage	V_{O-TV}	Mono TV or 80 mV AM input	600	708	1000	mV
LEFT and RIGHT output DC offset voltage	V_{VOC}	Mono, stereo or bilingual input	-190	0	190	mV
TV/FM DC offset voltage	V_{TVFM}	TV, FM or mute mode	-320	0	320	mV
Mono signal-to-noise ratio	S/N_{TVMO}	See note.	60	72	-	dB
Subchannel signal-to-noise ratio	S/N_{TVSUS}	See note.	60	66	-	dB
Mono total harmonic distortion	THD_{TVMO}	See note.	-	0.1	1.1	%
Subchannel total harmonic distortion	THD_{TVSUS}	See note.	-	1.6	3.6	%
Main-channel to subchannel separation	Sep	See note.	30	42	-	dB
Q-signal detection sensitivity	CS	Stereo or bilingual input	-	17	60	mV
Stereo Q-signal capture range	CR_{TVST}	$f_c = 982.5\text{ Hz}$, $f_b = 974.4\text{ Hz}$	-	-0.84	-	%
		$f_c = 982.5\text{ Hz}$, $f_b = 991.3\text{ Hz}$	-	0.90	-	
Bilingual Q-signal capture range	CR_{TVBL}	$f_c = 922.5\text{ Hz}$, $f_b = 912.0\text{ Hz}$	-	-1.2	-	%
		$f_c = 922.5\text{ Hz}$, $f_b = 942.2\text{ Hz}$	-	2.1	-	
Main-channel to subchannel crosstalk	C_{CS}	Bilingual input, 1 kHz BPF at input	60	67	-	dB
Channel balance	CB	TV or FM mode	-1.5	0	1.5	dB
Mute attenuation	$OM_{MUTE-TV}$		60	62	-	dB
7.5 kHz deemphasis attenuation	ODE	1 kHz reference	9.1	11.1	13.1	dB

LA3860

Parameter	Symbol	Condition	Rating			Unit
			min	typ	max	
Subchannel BPF attenuation	G _{sub}	f = 3f _H = 47.202 kHz, 100 mV input	3	-	-	dB
		f = 4.5f _H = 70.803 kHz, 100 mV input	11	-	-	
FADJ impedance range	R _{FA}		12	-	22	kΩ

Note

IHF/T200 (200 Hz to 15 kHz) input bandpass filter

FM mode

V_{CC} = 12 V, T_a = 25 °C, FM/TV/V_{COSTOP} is 0 V or open.

Parameter	Symbol	Condition	Rating			Unit
			min	typ	max	
FM output voltage	V _{OFM}	FM mono input	708	1000	1418	mV
FMLPF2 forced mono input voltage	V _F		-	4.0	5.5	V
Mono signal-to-noise ratio	SN _{FM}	FM mono input	75	86	-	dB
Mono total harmonic distortion	THD _{FM}	FM mono input	-	0.01	0.20	%
Dynamic range	D	480 mV mono input	-	0.04	0.30	%
Channel separation	Sep	Stereo input	40	57	-	dB
Pilot detection sensitivity	PS	Stereo input	30	73	120	mV
Pilot hysteresis	PH	Stereo input	-	2.5	6.0	dB
Pilot capture range	CR _{FM}	Stereo input, f ₀ = 19 kHz, 24 mV input	-	±1.3	-	%
Mute attenuation	G _{MUTE FM}		70	92	-	dB

Measurement Conditions

- The standard inputs are 80 mV, f = 1 kHz, 100% modulation signal for TV mono and 240 mV, f = 1 kHz, 100% modulation signal for FM mono.
- The TV-mode capture range is given by the following equations.

For stereo,

$$\left(\frac{f_{CR} - 982.5 \text{ Hz}}{982.5 \text{ Hz}} \right) \times 100\%$$

and for bilingual,

$$\left(\frac{f_{CR} - 922.5 \text{ Hz}}{922.5 \text{ Hz}} \right) \times 100\%$$

where f_{CR} is the upper and lower frequencies at which the stereo or bilingual LED turns ON. FM/TV/V_{COSTOP} is 5 V, and the input on PLL, 900 Hz to 1 kHz, 100 mV sine wave.

- The FM-mode capture range is given by the equation

$$\left(\frac{f_{CR} - 19 \text{ kHz}}{19 \text{ kHz}} \right) \times 100\%$$

where f_{CR} is the upper and lower frequencies at which the stereo LED turns ON. FM/TV/V_{COSTOP} is 0 V or open, and the input waveform, 24 mV at approximately 19 kHz.

- Crosstalk measurements are made with a 1 kHz input bandpass filter.
- The f = 3f_H and f = 4.5f_H subchannel bandpass filter attenuation is measured with respect to 47.202 kHz and 70.803 kHz, 100 mV input sine waves.
- The TV-mode DC offset voltage is given by the following equations.

$$V_{TVOF} = V_{ST} - V_{MONO}$$

$$V_{TVOF} = V_{MAIN} - V_{MONO}$$

$$V_{TVOF} = V_{SUB} - V_{MONO}$$

where V_{MONO}, V_{ST}, V_{MAIN} and V_{SUB} are the DC output voltages for mono, stereo and bilingual TV input signals (main-channel and subchannel), respectively. The TV/FM DC offset voltage is given by the following equations.

$$V_{TVFM} = V_{FM} - V_{TV}$$

$$V_{TVFM} = V_{MUTE} - V_{TV}$$

where V_{FM}, V_{TV} and V_{MUTE} are the DC output voltages for FM mono, TV mono and muted output signals, respectively.

- The 456 kHz ceramic resonator connected to OSC is a Murata CSB456F28.

LA3860

OPERATING MODE SELECTION

Mode		Control inputs			Output signals		LED display			
		FM/TV VCOSTOP	MAIN/MUTE	SUB	LEFT	RIGHT	ST	BIL		
FM (50 μ s deemphasis)	Mono	LOW	x	x	Mono		OFF			
	Stereo				Left	Right	ON	OFF		
TV (75 μ s deemphasis)	Mono	HIGH	x	x	Mono		OFF			
	Stereo				Left	Right	ON	OFF		
	Bilingual				LOW	LOW	Main	Sub	OFF	ON
					LOW	HIGH	Main			
	HIGH	LOW	Sub							
AM (75 μ s deemphasis)	AM	10 V	x	x	Mono		OFF			
	x	x	10 V	x	Mute		x			

Notes

1. LOW = 0 V or open, HIGH = 5 V, x = don't care
2. MAIN/MUTE and SUB should not both be HIGH simultaneously.

Adjustments

Filter adjustment

Input a stereo or bilingual TV signal and adjust the trimmer resistor connected to FADJ for maximum DC voltage on PLL.

TV channel separation adjustment

After filter adjustment, input a composite TV signal (equivalent to an 80 mV mono signal) on one channel (left or right) and adjust the trimmer resistor connected to TVSEPADJ for minimum level on the other channel output.

FM channel separation adjustment

Input a composite FM signal (equivalent to a 240 mV mono signal) on one channel (left or right) and adjust the trimmer resistor connected to FMSEPADJ for minimum level on the other channel output.

DESIGN INFORMATION

Input Signal Polarity

If the stereo left- and right-channel outputs are inverted or the bilingual main-channel and subchannel outputs

are reversed because of the sound IF amplifier signal polarity, invert the input signal using a transistor.

LA3860

TYPICAL APPLICATION

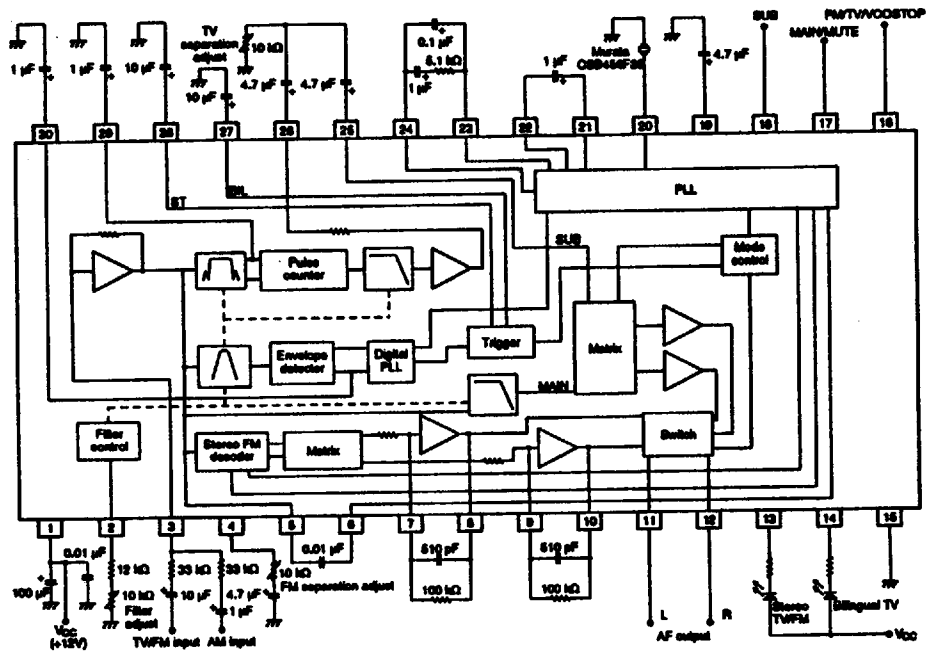

Information (including circuit diagrams and circuit parameters) herein is for example only; it is not guaranteed for volume production. SANYO believes information herein is accurate and reliable, but no guarantees are made or implied regarding its use or any infringements of intellectual property rights or other rights of third parties.