



LM39102

LINEAR INTEGRATED CIRCUIT

1A LOW-VOLTAGE LOW-DROPOUT REGULATOR

DESCRIPTION

The UTC **LM39102** is a low-dropout linear voltage regulator that provide low-voltage, high-current output.

The UTC **LM39102** can be used in a wide field because of Adjustable Output. UTC **LM39102** is fully protected with over current limiting, thermal shutdown, and reversed-battery protection.

FEATURES

- * Adjustable output voltages refer to 1.24V
- * Dropout Voltage 410mV at 1A output
Ideal for 3.0V~2.5V conversion
Ideal for 2.5V~1.8V or 1.5V conversion
- * ON/OFF control function
- * 1% initial accuracy
- * Built-in current limiting and thermal shutdown
- * Reversed-battery protection
- * Reversed-leakage protection
- * Fast transient response

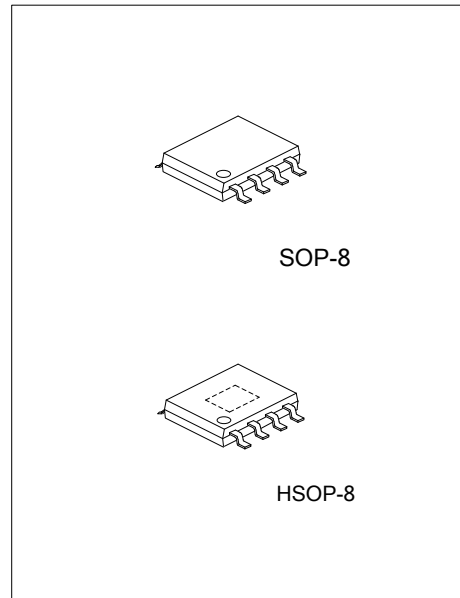

ORDERING INFORMATION

Ordering Number		Package	Packing
Lead Free	Halogen Free		
LM39102L-S08-R	LM39102G-S08-R	SOP-8	Tape Reel
LM39102L-SH2-R	LM39102G-SH2-R	HSOP-8	Tape Reel

<p>LM39102G-S08-R</p> <p>(1) Packing Type</p> <p>(2) Package Type</p> <p>(3) Green Package</p>	<p>(1) R: Tape Reel</p> <p>(2) S08: SOP-8, SH2: HSOP-8</p> <p>(3) G: Halogen Free and Lead Free, L: Lead Free</p>
--	---

MARKING

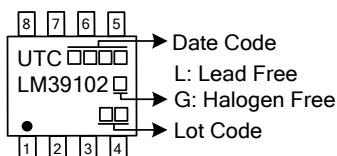

■ PIN CONFIGURATION

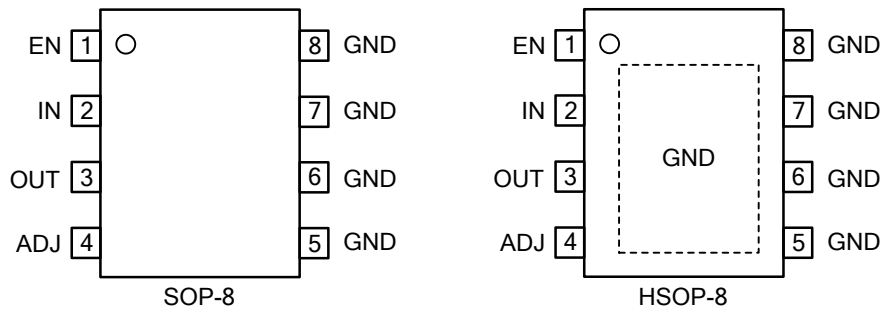

■ PIN DESCRIPTION

PIN NO.	PIN NAME	DESCRIPTION
1	EN	ON/OFF control terminal
2	IN	Power Supply
3	OUT	Regulator output
4	ADJ	Adjustment terminal: feedback input
5, 6, 7, 8	GND	Ground

■ BLOCK DIAGRAM

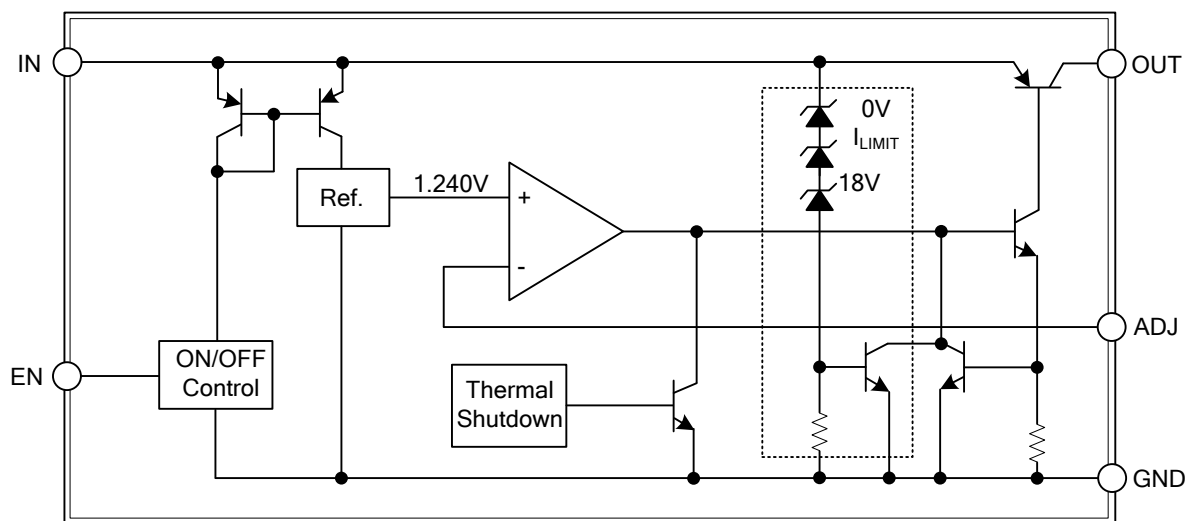

■ ABSOLUTE MAXIMUM RATING

PARAMETER	SYMBOL	RATINGS	UNIT
Supply Voltage	V_{IN}	18V	V
Enable Voltage	V_{EN}	+20	V
Junction Temperature	T_J	-40 ~ +125	°C
Storage Temperature	T_{STG}	-65 ~ +150	°C

Note: Absolute maximum ratings are those values beyond which the device could be permanently damaged.
 Absolute maximum ratings are stress ratings only and functional device operation is not implied.

■ OPERATING RATINGS (Note 1)

PARAMETER	SYMBOL	RATINGS	UNIT
Supply Voltage	V_{IN}	+2.25 ~ +16	V
Enable Voltage	V_{EN}	+16	V
Maximum Power Dissipation	P_D	Note 2	

Notes: 1. The device is not guaranteed to function outside its operating rating.
 2. $P_{D(max)} = (T_J(max) - T_A) / \theta_{JA}$, where θ_{JA} - junction-to-ambient thermal resistance.

■ THERMAL DATA

PARAMETER	SYMBOL	RATINGS	UNIT
Junction to Case	θ_{JC}	50	°C/W
		45	°C/W

■ ELECTRICAL CHARACTERISTICS

($V_{IN}=V_{OUT}+1V$, $V_{EN}=2.25V$, $T_J=25^{\circ}C$, bold values indicate $0^{\circ}C \leq T_J \leq +125^{\circ}C$, unless noted)

PARAMETER	SYMBOL	TEST CONDITIONS	MIN	TYP	MAX	UNIT
Output Voltage	V_{OUT}	10mA	-1		1	%
		$10mA \leq I_{OUT} \leq 1A$, $V_{OUT}+1V \leq V_{IN} \leq 8V$	-2		2	%
Line Regulation		$I_{OUT}=10mA$, $V_{OUT}+1V \leq V_{IN} \leq 16V$		0.06	0.5	%
Load Regulation		$V_{IN}=V_{OUT}+1V$, $10mA \leq I_{OUT} \leq 1A$		0.2	1	%
Output Voltage Temperature Coefficient (Note 1)	$\Delta V_{OUT}/\Delta T$			40	100	ppm/ $^{\circ}C$
Dropout Voltage (Note 2)	V_{DO}	$I_{OUT}=100mA$, $\Delta V_{OUT}=-1\%$		150	200	mV
					250	mV
		$I_{OUT}=500mA$, $\Delta V_{OUT}=-1\%$		275		mV
		$I_{OUT}=750mA$, $\Delta V_{OUT}=-1\%$		330	500	mV
Ground Current (Note 3)	I_{GND}	$I_{OUT}=100mA$, $V_{IN}=V_{OUT}+1V$		700		μA
		$I_{OUT}=500mA$, $V_{IN}=V_{OUT}+1V$		12		mA
		$I_{OUT}=750mA$, $V_{IN}=V_{OUT}+1V$		25		mA
Current Limit	$I_{OUT(lim)}$	$V_{OUT}=0V$, $V_{IN}=V_{OUT}+1V$		1.8	2.5	A
Enable Input						
Enable Input Voltage	V_{EN}	Logic Low (Off)			0.8	V
		Logic High (On)	2.25			V
Enable Input Current	I_{EN}	$V_{EN}=2.25V$	1	15	30	μA
					75	μA
		$V_{EN}=0.8V$			2	μA
Reference Voltage			1.228	1.240	1.252	V
			1.215		1.265	V
		Note 4	1.203		1.277	V
Adjust Pin Bias Current				40	80	nA
					120	nA
Reference Voltage Temperature Coefficient (Note 1)				20		ppm/ $^{\circ}C$
Adjust Pin Bias Current Temperature Coefficient				0.1	99.2	nA/ $^{\circ}C$

Notes: 1. Output voltage temperature coefficient is $\Delta V_{OUT(worst\ case)} + (T_{J(max)} - T_{J(min)})$ where $T_{J(max)}$ is $+125^{\circ}C$ and $T_{J(min)}$ is $0^{\circ}C$.

2. $V_{DO}=V_{IN}-V_{OUT}$ when V_{OUT} decreases to 99% of its nominal output voltage with $V_{IN}=V_{OUT}+1V$. For output voltages below 2.25V, dropout voltage is the input-to-output voltage differential with the minimum input voltage being 2.25V. Minimum input operating voltage is 2.25V.

3. I_{GND} is the quiescent current. $I_{IN}=I_{GND}+I_{OUT}$.

4. $V_{REF} \leq V_{OUT} \leq (V_{IN}-1V)$, $2.25V \leq V_{IN} \leq 16V$, $10mA \leq I_L \leq 1A$.

■ TYPICAL APPLICATION CIRCUIT

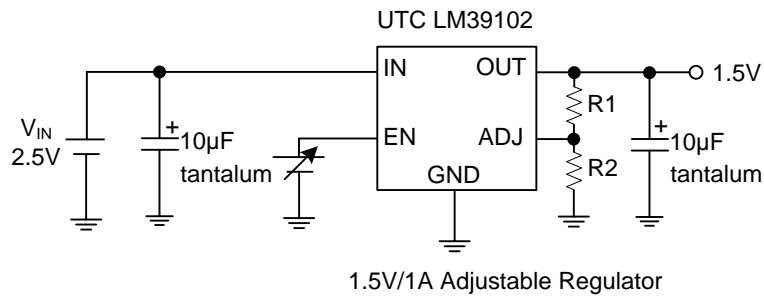

UTC assumes no responsibility for equipment failures that result from using products at values that exceed, even momentarily, rated values (such as maximum ratings, operating condition ranges, or other parameters) listed in products specifications of any and all UTC products described or contained herein. UTC products are not designed for use in life support appliances, devices or systems where malfunction of these products can be reasonably expected to result in personal injury. Reproduction in whole or in part is prohibited without the prior written consent of the copyright owner. UTC reserves the right to make changes to information published in this document, including without limitation specifications and product descriptions, at any time and without notice. This document supersedes and replaces all information supplied prior to the publication hereof.