

## Stereo 14W Audio Power Amplifier with Mute and Standby Modes

### General Description

The LM4730 is a stereo audio amplifier capable of delivering typically 14W per channel of continuous average output power into a 4Ω or 8Ω load with less than 10% THD+N from 20Hz - 20kHz.

Each amplifier has an independent smooth transition fade-in/out mute and a power conserving standby mode which can be controlled by external logic.

The LM4730 has short circuit protection and a thermal shut down feature that is activated when the die temperature exceeds 150°C. The LM4730 also has a under voltage lock out feature for click and pop free power off and on.

The LM4730 has a wide operating supply range from +/-10V - +/-25V allowing for lower cost unregulated power supplies to be used.

### Key Specifications

- Output power into 4Ω or 8Ω, 10% THD+N 14W (typ)
- THD+N at 1kHz with 2 X 1W into 8Ω 0.02% (typ)
- Mute Attenuation 85dB (typ)
- PSRR with  $f_{\text{RIPPLE}} = 120\text{Hz}$ ,  $V_{\text{RIPPLE}} = 1V_{\text{RMS}}$  50dB (typ)
- Slew Rate 18V/μs (typ)
- Standby Current (+/-17V) 3.5mA (typ)

### Features

- Minimal amount of external components necessary
- Quiet fade-in/out mute mode
- Low current Standby-mode

### Applications

- Audio amplifier for high-end stereo TVs
- Audio amplifier for component stereo
- Audio amplifier for compact stereo
- Audio amplifier for PC satellite speaker systems
- Audio amplifier for self powered speakers

### Connection Diagrams

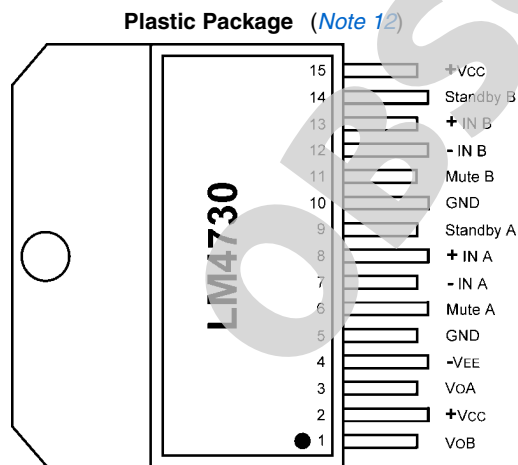

**Top View**  
Non-Isolated Package  
Order Number LM4730TA  
See NS Package Number TA15A

20059452

**TO-220 Top Marking (Note 12)**

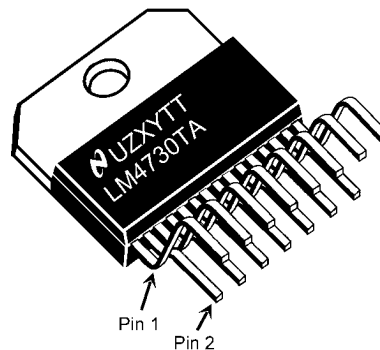

20059474

**Top View**  
U - Wafer Fab Code  
Z - Assembly Plant Code  
XY - Date Code  
TT - Die Traceability  
LM4730TA - LM4730TA

# Typical Application

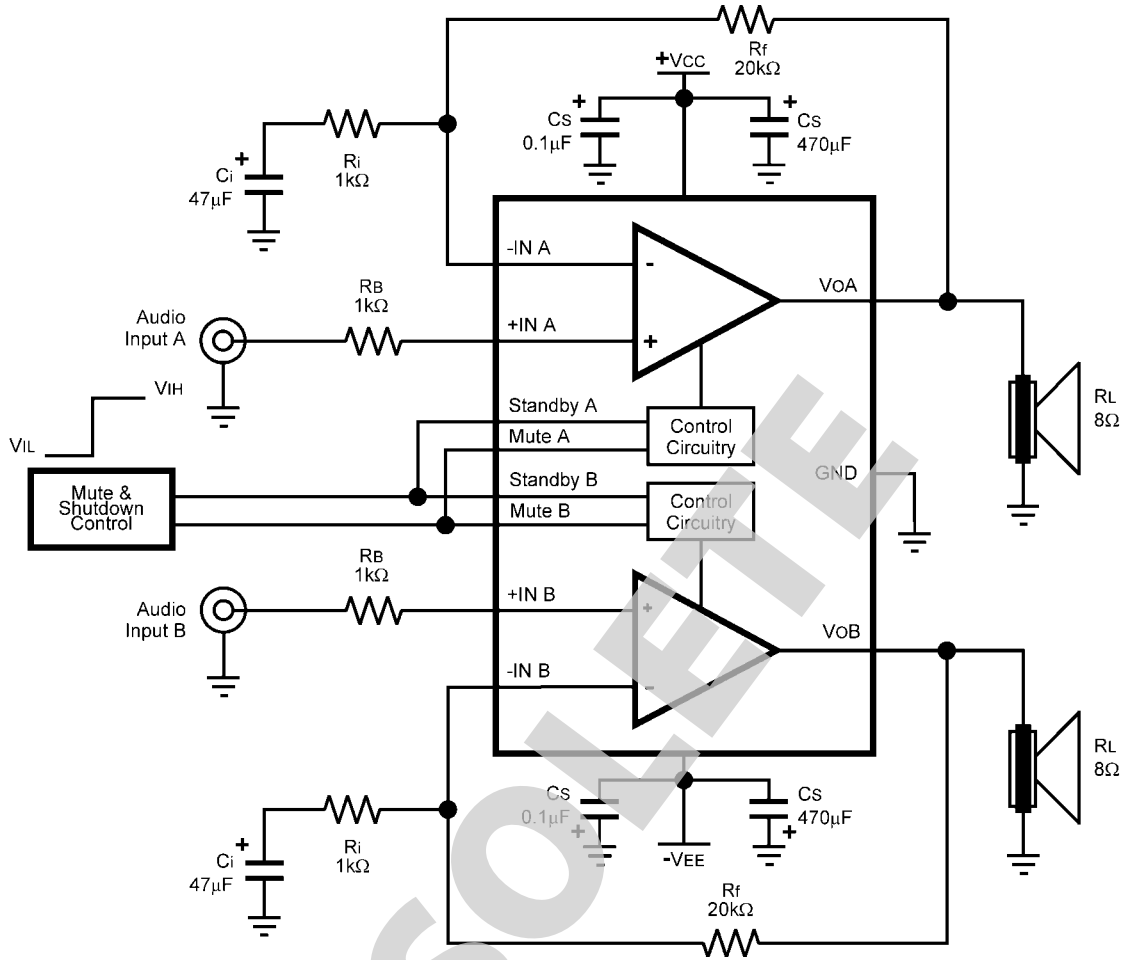

20059453

FIGURE 1. Typical Audio Amplifier Application Circuit

**Absolute Maximum Ratings** (Note 1, Note 2)

2)

If Military/Aerospace specified devices are required, please contact the National Semiconductor Sales Office/Distributors for availability and specifications.

Supply Voltage $V_{+I} + V_{-I}$	50V
Common Mode Input Voltage	$V_{+}$ or $V_{-}$
Differential Input Voltage	50V
Output Current	Internally Limited
Power Dissipation (Note 3)	40W
ESD Susceptibility (Note 4)	2.0kV
ESD Susceptibility (Note 5)	250V

Junction Temperature ( $T_{JMAX}$ ) (Note 9)	150°C
Soldering Information	
T Package (10 sec.)	260°C
Storage Temperature	-40°C to +150°C
Thermal Resistance	
$\theta_{JA}$ (TA)	43°C/W
$\theta_{JC}$ (TA)	1.5°C/W

**Operating Ratings** (Note 1, Note 2)

Temperature Range	
$T_{MIN} \leq T_A \leq T_{MAX}$	-20°C $\leq$ $T_A$ $\leq$ +85°C
Supply Voltage $V_{+I} + V_{-I}$	20V $\leq$ $V_{TOTAL} \leq$ 50V

**Electrical Characteristics** (Note 1, Note 2)

The following specifications apply for  $V_{+} = +17V$ ,  $V_{-} = -17V$  and  $R_L = 8\Omega$  unless otherwise specified. Limits apply for  $T_A = 25^\circ C$ .

Symbol	Parameter	Conditions	LM4730		Units (Limits)
			Typical (Note 6)	Limit (Note 7, Note 8)	
$V_{+I} + V_{-I}$	Power Supply Voltage (Note 10)	$GND - V_{-} \geq 9V$		20 50	V (min) V (max)
$A_M$	Mute Attenuation		85		dB
$P_O$	Output Power (RMS)	THD+N = 10% (max), f = 1kHz $V_{+I} = V_{-I} = 14V$ , $R_L = 4\Omega$ $V_{+I} = V_{-I} = 17V$ , $R_L = 8\Omega$	14 14	12 12	W (min) W (min)
		THD+N = 1% (max), f = 1kHz $V_{+I} = V_{-I} = 14V$ , $R_L = 4\Omega$ $V_{+I} = V_{-I} = 17V$ , $R_L = 8\Omega$	11 11	9 9	W (min) W (min)
THD+N	Total Harmonic Distortion + Noise	$P_O = 1W$ , f = 1kHz $A_V = 26dB$ $V_{+I} = V_{-I} = 14V$ , $R_L = 4\Omega$ $V_{+I} = V_{-I} = 17V$ , $R_L = 8\Omega$	0.03 0.02	0.5 0.3	% (max) % (max)
$X_{talk}$	Channel Separation	$P_O = 10W$ f = 1kHz	65		dB
		f = 10kHz	60		dB
SR	Slew Rate (Note 11)	$V_{IN} = 2.0V_{p-p}$ , $t_{rise} = 2ns$	18		V/ $\mu s$
$I_{DD}$	Total Quiescent Power Supply Current	$V_{CM} = 0V$ , $V_O = 0V$ , $I_O = 0A$ Standby off (Play Mode)	90	100	mA (max)
		Standby on (Standby Mode)	3.5	6	mA (max)
$V_{OS}$	Input Offset Voltage	$V_{CM} = 0V$ , $I_O = 0mA$	2.0	15	mV (max)
$I_B$	Input Bias Current	$V_{CM} = 0V$ , $I_O = 0mA$	0.2		$\mu A$
PSRR	Power Supply Rejection Ratio	$V_{RIPPLE} = 1V_{RMS}$ , $f_{RIPPLE} = 120Hz$ sine wave Inputs terminated to GND	50		dB
$A_{VOL}$	Open Loop Voltage Gain	$R_L = 2k\Omega$ , $\Delta V_O = 20V$	110		dB
$e_{IN}$	Input Noise	IHF — A-Weighting Filter $R_{IN} = 600\Omega$ (Input Referred)	2.0	8	$\mu V$ (max)
Standby	$V_{IL}$	Standby Low Input Voltage		0.8	V (max)
	$V_{IH}$	Standby High Input Voltage	2.0	2.5	V (min)

Symbol	Parameter	Conditions	LM4730		Units (Limits)
			Typical (Note 6)	Limit (Note 7, Note 8)	
Mute					
V <sub>IL</sub>	Mute Low Input Voltage	Not in Mute Mode (Play)		0.8	V (max)
V <sub>IH</sub>	Mute High Input Voltage	In Mute Mode	2.0	2.5	V (min)

**Note 1:** All voltages are measured with respect to the ground pin, unless otherwise specified.

**Note 2:** Absolute Maximum Ratings indicate limits beyond which damage to the device may occur. Operating Ratings indicate conditions for which the device is functional, but do not guarantee specific performance limits. Electrical Characteristics state DC and AC electrical specifications under particular test conditions which guarantee specific performance limits. This assumes that the device is within the Operating Ratings. Specifications are not guaranteed for parameters where no limit is given. However, the typical value is a good indication of a device's performance.

**Note 3:** The maximum power dissipation must be de-rated at elevated temperatures and is dictated by  $T_{JMAX}$ ,  $\theta_{JC}$ , and the ambient temperature  $T_A$ . The maximum allowable power dissipation is  $P_{DMAX} = (T_{JMAX} - T_A) / \theta_{JC}$  or the number given in the Absolute Maximum Ratings, whichever is lower. For the LM4730,  $T_{JMAX} = 150^\circ\text{C}$  and the typical  $\theta_{JC}$  is  $1.5^\circ\text{C/W}$  for the TA15A package. Refer to the Thermal Considerations section for more information.

**Note 4:** Human body model, 100 pF discharged through a 1.5 k $\Omega$  resistor.

**Note 5:** Machine Model: a 220pF - 240pF discharged through all pins.

**Note 6:** Typical specifications are specified at  $25^\circ\text{C}$  and represent the parametric norm.

**Note 7:** Tested limits are guaranteed to National's AOQL (Average Outgoing Quality Level).

**Note 8:** Datasheet min/max specification limits are guaranteed by design, test, or statistical analysis.

**Note 9:** The operating junction temperature maximum is  $150^\circ\text{C}$ . However, the instantaneous Safe Operating Area temperature is  $250^\circ\text{C}$ .

**Note 10:** V<sup>-</sup> must have at least -9V at its pin with reference to GND in order for the under-voltage protection circuitry to be disabled. In addition, the voltage differential between V<sup>+</sup> and V<sup>-</sup> must be greater than 14V.

**Note 11:** The feedback compensation network limits the bandwidth of the closed-loop response causing the skew rate to be reduced by the high frequency roll-off. Without feedback compensation the slew rate is typically larger.

**Note 12:** The LM4730TA package TA15A is a non-isolated package setting the tab of the device and the heat sink to V-potential when the LM4730TA is directly mounted to the heat sink using only thermal compound. If a mica washer is used in addition to thermal compound,  $\theta_{CS}$  (case to sink) is increased, but the heat sink will be electrically isolated from V<sup>-</sup>.

OBSOLETE

## Bridged Amplifier Application Circuit

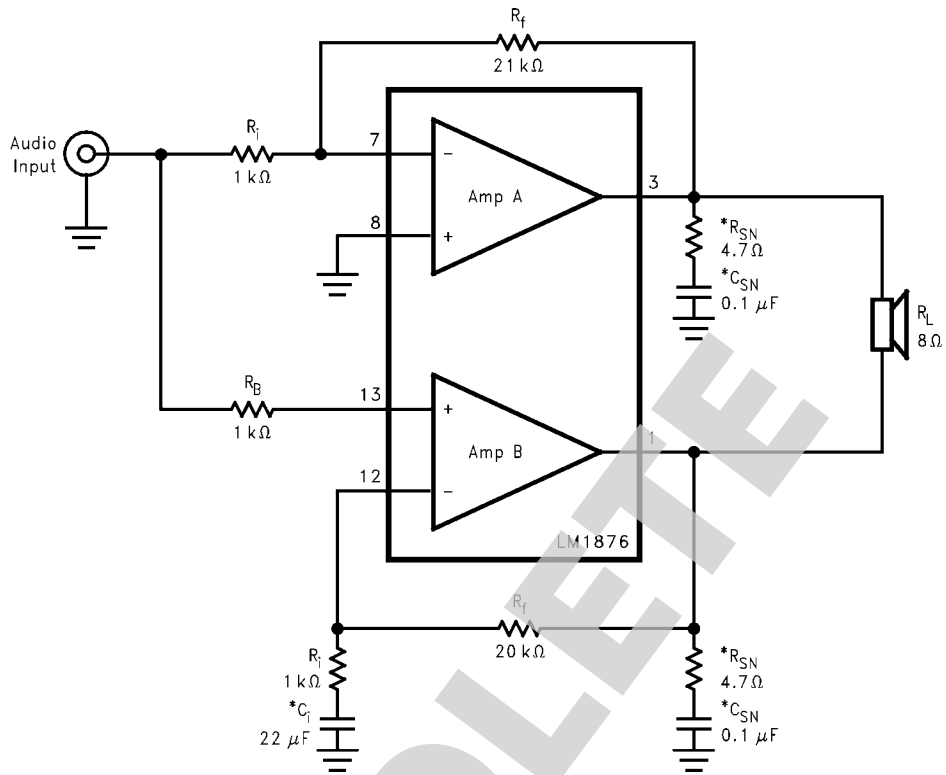

20059405

FIGURE 2. Bridged Amplifier Application Circuit

## Single Supply Application Circuit

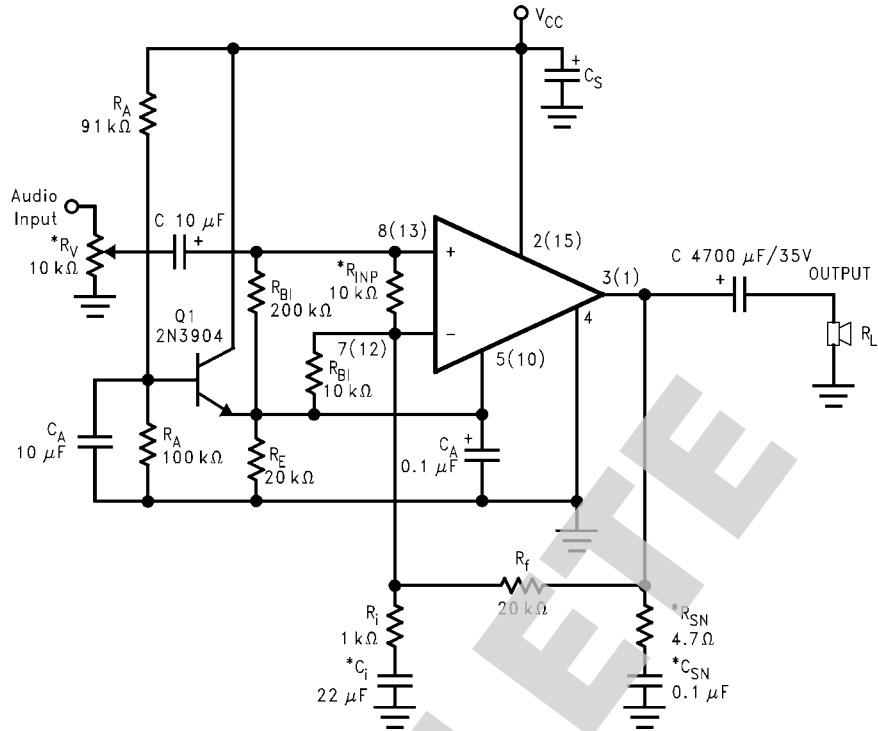

20059406

FIGURE 3. Single Supply Amplifier Application Circuit

Note: \*Optional components dependent upon specific design requirements.

## Auxiliary Amplifier Application Circuit

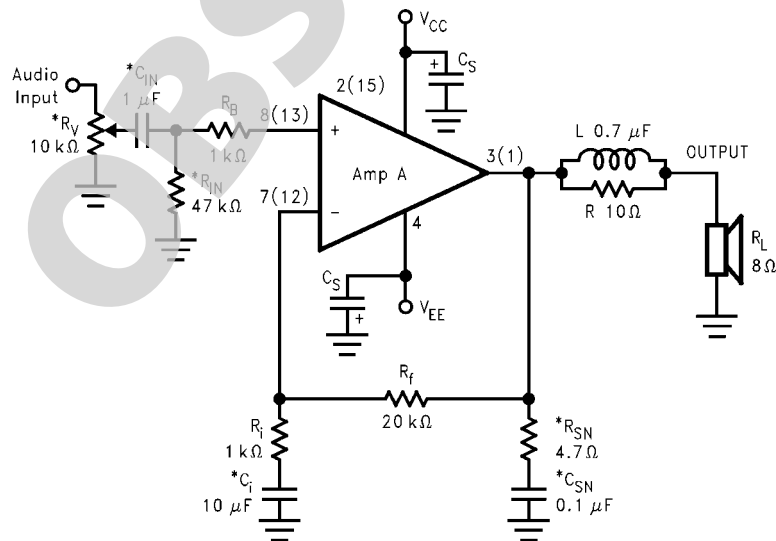

20059407

FIGURE 4. Special Audio Amplifier Application Circuit

## External Components Description

( See Figures 1 - 4 )

Components		Functional Description
1	$R_B$	Prevents currents from entering the amplifier's non-inverting input which may be passed through to the load upon power down of the system due to the low input impedance of the circuitry when the undervoltage circuitry is off. This phenomenon occurs when the supply voltages are below 1.5V.
2	$R_i$	Inverting input resistance to provide AC gain in conjunction with $R_f$ .
3	$R_f$	Feedback resistance to provide AC gain in conjunction with $R_i$ .
4	$C_i$ (Note 13)	Feedback capacitor which ensures unity gain at DC. Also creates a highpass filter with $R_i$ at $f_C = 1/(2\pi R_i C_i)$ .
5	$C_S$	Provides power supply filtering and bypassing. Refer to the Supply Bypassing application section for proper placement and selection of bypass capacitors.
6	$R_V$ (Note 13)	Acts as a volume control by setting the input voltage level.
7	$R_{IN}$ (Note 13)	Sets the amplifier's input terminals DC bias point when $C_{IN}$ is present in the circuit. Also works with $C_{IN}$ to create a highpass filter at $f_C = 1/(2\pi R_{IN} C_{IN})$ . Refer to <a href="#">Figure 4</a> .
8	$C_{IN}$ (Note 13)	Input capacitor which blocks the input signal's DC offsets from being passed onto the amplifier's inputs.
9	$R_{SN}$ (Note 13)	Works with $C_{SN}$ to stabilize the output stage by creating a pole that reduces high frequency instabilities.
10	$C_{SN}$ (Note 13)	Works with $R_{SN}$ to stabilize the output stage by creating a pole that reduces high frequency instabilities. The pole is set at $f_C = 1/(2\pi R_{SN} C_{SN})$ . Refer to <a href="#">Figure 4</a> .
11	$L$ (Note 13)	Provides high impedance at high frequencies so that R may decouple a highly capacitive load and reduce the Q of the series resonant circuit. Also provides a low impedance at low frequencies to short out R and pass audio signals to the load. Refer to <a href="#">Figure 4</a> .
12	$R$ (Note 13)	
13	$R_A$	Provides DC voltage biasing for the transistor Q1 in single supply operation.
14	$C_A$	Provides bias filtering for single supply operation.
15	$R_{INP}$ (Note 13)	Limits the voltage difference between the amplifier's inputs for single supply operation. Refer to the <b>Clicks and Pops</b> application section for a more detailed explanation of the function of $R_{INP}$ .
16	$R_{BI}$	Provides input bias current for single supply operation. Refer to the <b>Clicks and Pops</b> application section for a more detailed explanation of the function of $R_{BI}$ .
17	$R_E$	Establishes a fixed DC current for the transistor Q1 in single supply operation. This resistor stabilizes the half-supply point along with $C_A$ .

**Note 13:** Optional components dependent upon specific design requirements.

# Typical Performance Characteristics

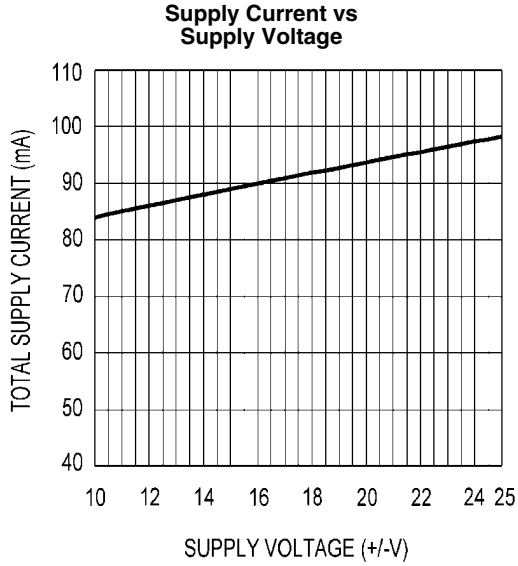

20059467

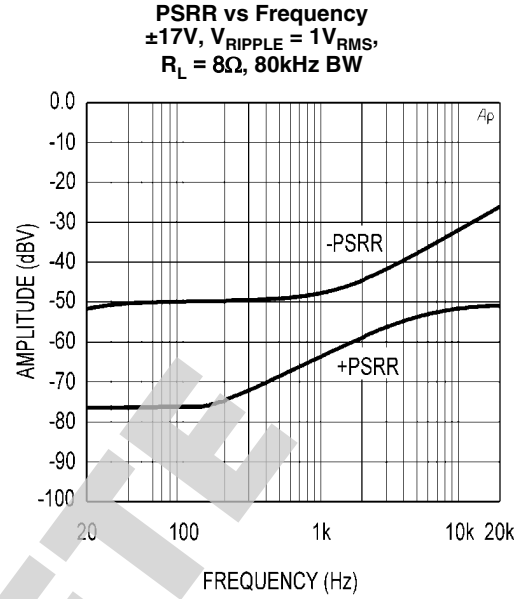

20059464

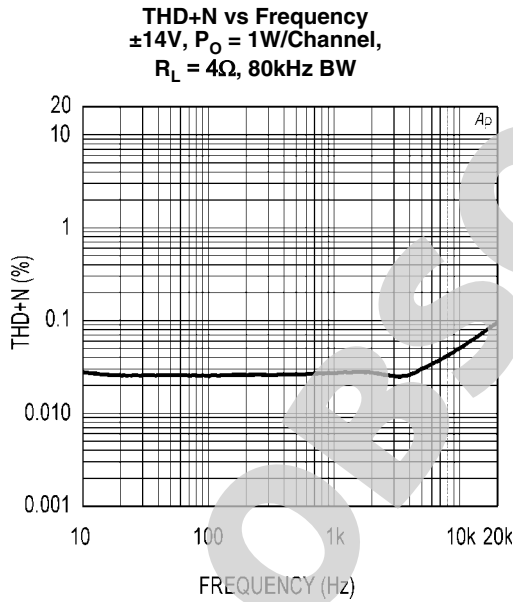

20059468

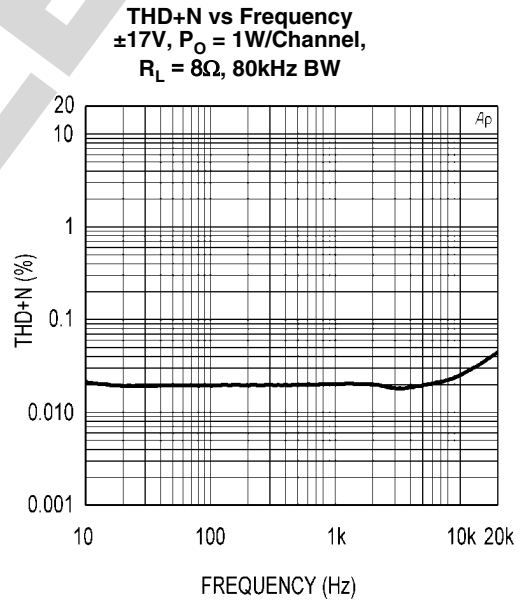

20059469



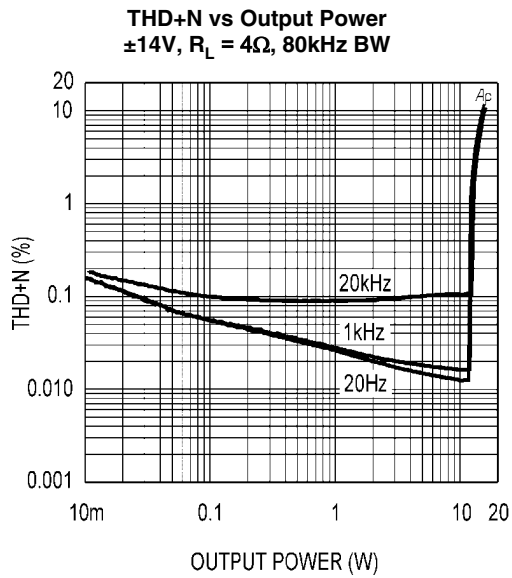

20059470

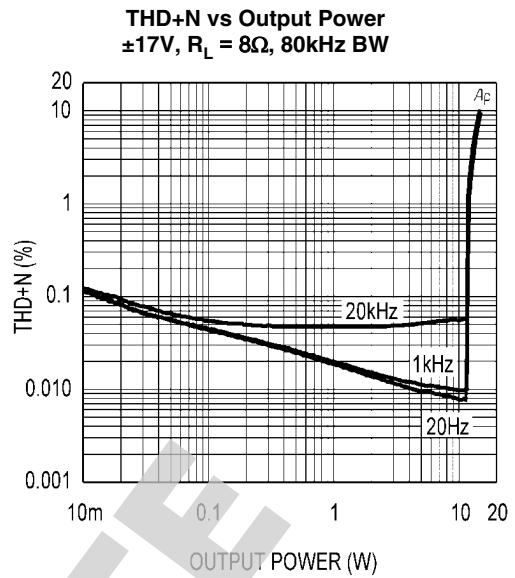

20059471

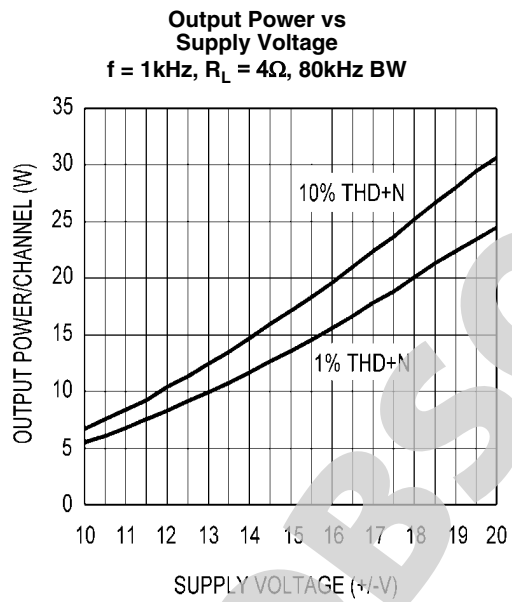

20059462

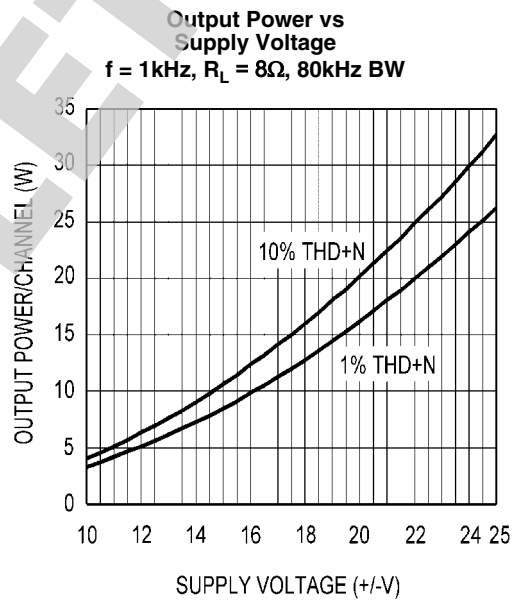

20059463

**Power Dissipation vs Output Power**  
 1% THD (max),  $R_L = 4\Omega$ , 80kHz BW

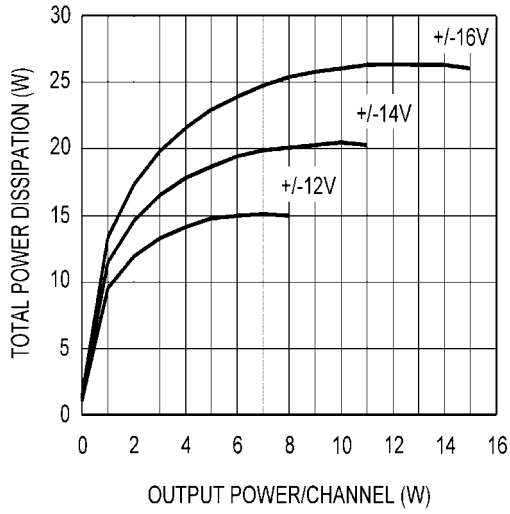

20059460

**Power Dissipation vs Output Power**  
 1% THD (max),  $R_L = 8\Omega$ , 80kHz BW

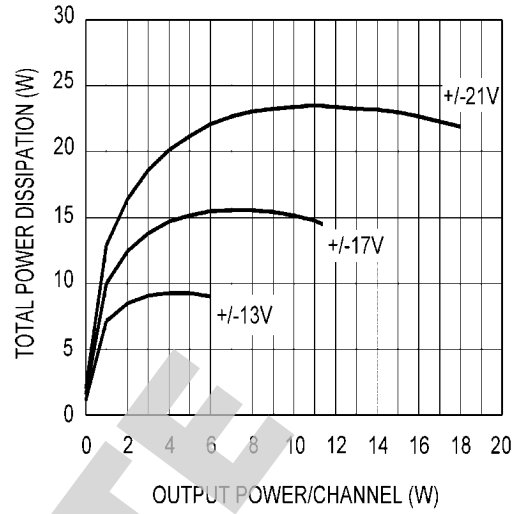

20059461

**Crosstalk vs Frequency**  
 $\pm 14V$ ,  $P_O = 10W$ ,  
 $R_L = 4\Omega$ , 80kHz BW

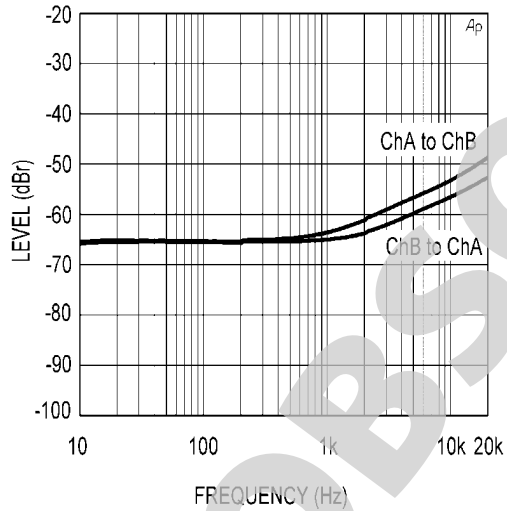

20059472

**Crosstalk vs Frequency**  
 $\pm 17V$ ,  $P_O = 10W$ ,  
 $R_L = 8\Omega$ , 80kHz BW

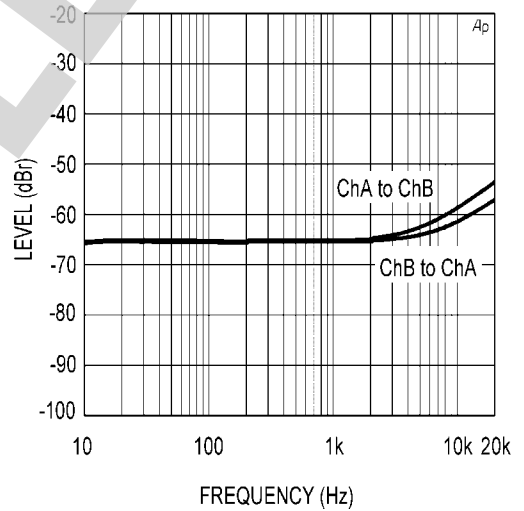

20059473

**Mute Attenuation vs  
Mute Pin Voltage**  
±17V,  $P_O = 1W$ ,  
 $R_L = 8\Omega$ , 80kHz BW

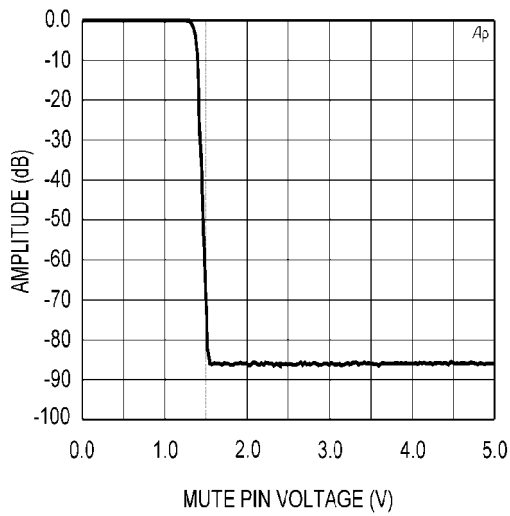

20059459

**Standby Attenuation vs  
Standby Pin Voltage**  
±17V,  $P_O = 1W$ ,  
 $R_L = 8\Omega$ , 80kHz BW

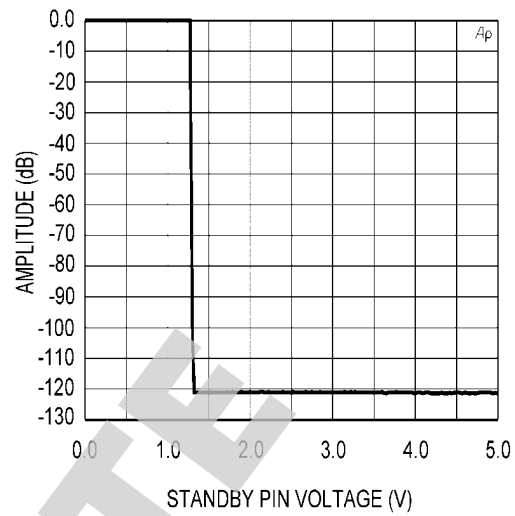

20059465

**Supply Current vs  
Standby Pin Voltage**  
±17V

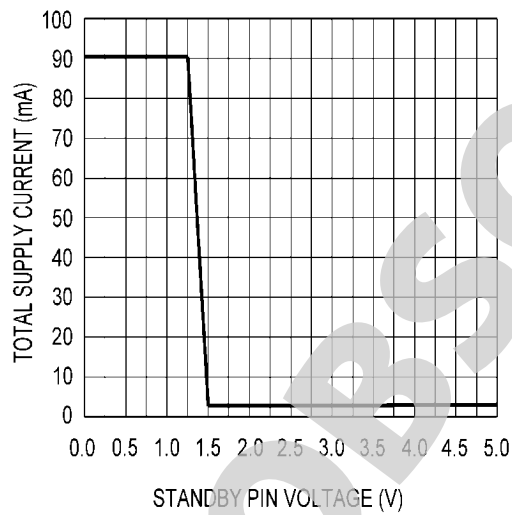

20059466

## Application Information

### MUTE MODE

By placing a logic-high voltage on the mute pins, the signal going into the amplifiers will be muted. If the mute pins are left floating or connected to a logic-low voltage, the amplifiers will be in a non-muted state. There are two mute pins, one for each amplifier, so that one channel can be muted without muting the other if the application requires such a configuration. Refer to the **Typical Performance Characteristics** section for curves concerning Mute Attenuation vs Mute Pin Voltage.

### STANDBY MODE

The standby mode of the LM4730 allows the user to drastically reduce power consumption when the amplifiers are idle. By placing a logic-high voltage on the standby pins, the amplifiers will go into Standby Mode. In this mode, the current drawn from the  $V_{CC}$  supply is typically less than 10  $\mu$ A total for both amplifiers. The current drawn from the  $V_{EE}$  supply is typically 3.5mA. Clearly, there is a significant reduction in idle power consumption when using the standby mode. There are two Standby pins, so that one channel can be put in standby mode without putting the other amplifier in standby if the application requires such flexibility. Refer to the **Typical Performance Characteristics** section for curves showing Supply Current vs. Standby Pin Voltage for both supplies.

### UNDER-VOLTAGE PROTECTION

Upon system power-up, the under-voltage protection circuitry allows the power supplies and their corresponding capacitors to come up close to their full values before turning on the LM4730 such that no DC output spikes occur. Upon turn-off, the output of the LM4730 is brought to ground before the power supplies such that no transients occur at power-down.

### OVER-VOLTAGE PROTECTION

The LM4730 contains over-voltage protection circuitry that limits the output current while also providing voltage clamping, though not through internal clamping diodes. The clamping effect is quite the same, however, the output transistors are designed to work alternately by sinking large current spikes.

### THERMAL PROTECTION

The LM4730 has a sophisticated thermal protection scheme to prevent long-term thermal stress of the device. When the temperature on the die exceeds 150°C, the LM4730 shuts down. It starts operating again when the die temperature drops to about 145°C, but if the temperature again begins to rise, shutdown will occur again above 150°C. Therefore, the device is allowed to heat up to a relatively high temperature if the fault condition is temporary, but a sustained fault will cause the device to cycle in a Schmitt Trigger fashion between the thermal shutdown temperature limits of 150°C and 145°C. This greatly reduces the stress imposed on the IC by thermal cycling, which in turn improves its reliability under sustained fault conditions.

Since the die temperature is directly dependent upon the heat sink used, the heat sink should be chosen such that thermal shutdown will not be reached during normal operation. Using the best heat sink possible within the cost and space constraints of the system will improve the long-term reliability of any power semiconductor device, as discussed in the **Determining the Correct Heat Sink** Section.

### DETERMINING MAXIMUM POWER DISSIPATION

Power dissipation within the integrated circuit package is a very important parameter requiring a thorough understanding if optimum power output is to be obtained. An incorrect maximum power dissipation calculation may result in inadequate heat sinking causing thermal shutdown and thus limiting the output power.

Equation (1) exemplifies the theoretical maximum power dissipation point of each amplifier where  $V_{CC}$  is the total supply voltage.

$$P_{DMAX} = V_{CC}^2 / 2\pi^2 R_L \quad (1)$$

Thus by knowing the total supply voltage and rated output load, the maximum power dissipation point can be calculated. The package dissipation is twice the number which results from equation (1) since there are two amplifiers in each LM4730. Refer to the graphs of Power Dissipation versus Output Power in the **Typical Performance Characteristics** section which show the actual full range of power dissipation not just the maximum theoretical point that results from equation (1).

### DETERMINING THE CORRECT HEAT SINK

The choice of a heat sink for a high-power audio amplifier is made entirely to keep the die temperature at a level such that the thermal protection circuitry does not operate under normal circumstances.

The thermal resistance from the die (junction) to the outside air (ambient) is a combination of three thermal resistances,  $\theta_{JC}$ ,  $\theta_{CS}$ , and  $\theta_{SA}$ . In addition, the thermal resistance,  $\theta_{JC}$  (junction to case), of the LM4730TA is 1.5°C/W. Using Thermalloy Thermacote thermal compound, the thermal resistance,  $\theta_{CS}$  (case to sink), is about 0.2°C/W. Since convection heat flow (power dissipation) is analogous to current flow, thermal resistance is analogous to electrical resistance, and temperature drops are analogous to voltage drops, the power dissipation out of the LM4730 is equal to the following:

$$P_{DMAX} = (T_{JMAX} - T_{AMB}) / \theta_{JA} \quad (2)$$

where  $T_{JMAX} = 150^\circ\text{C}$ ,  $T_{AMB}$  is the system ambient temperature and  $\theta_{JA} = \theta_{JC} + \theta_{CS} + \theta_{SA}$ .

Once the maximum package power dissipation has been calculated using equation (1), the maximum thermal resistance,  $\theta_{SA}$ , (heat sink to ambient) in °C/W for a heat sink can be calculated. This calculation is made using equation (2) which is derived by solving for  $\theta_{SA}$  in equation (2).

$$\theta_{SA} = [(T_{JMAX} - T_{AMB}) - P_{DMAX}(\theta_{JC} + \theta_{CS})] / P_{DMAX} \quad (3)$$

Again it must be noted that the value of  $\theta_{SA}$  is dependent upon the system designer's amplifier requirements. If the ambient temperature that the audio amplifier is to be working under is higher than 25°C, then the thermal resistance for the heat sink, given all other things are equal, will need to be smaller.

### SUPPLY BYPASSING

The LM4730 has excellent power supply rejection and does not require a regulated supply. However, to improve system performance as well as eliminate possible oscillations, the LM4730 should have its supply leads bypassed with low-inductance capacitors having short leads that are located close to the package terminals. Inadequate power supply bypassing will manifest itself by a low frequency oscillation known as "motorboating" or by high frequency instabilities. These instabilities can be eliminated through multiple bypassing utilizing a large tantalum or electrolytic capacitor (10  $\mu$ F or larger) which is used to absorb low frequency variations and

a small ceramic capacitor (0.1  $\mu\text{F}$ ) to prevent any high frequency feedback through the power supply lines.

If adequate bypassing is not provided, the current in the supply leads which is a rectified component of the load current may be fed back into internal circuitry. This signal causes distortion at high frequencies requiring that the supplies be bypassed at the package terminals with an electrolytic capacitor of 470  $\mu\text{F}$  or more.

### BRIDGED AMPLIFIER APPLICATION

The LM4730 has two operational amplifiers internally, allowing for a few different amplifier configurations. One of these configurations is referred to as “bridged mode” and involves driving the load differentially through the LM4730’s outputs. This configuration is shown in [Figure 2](#). Bridged mode operation is different from the classical single-ended amplifier configuration where one side of its load is connected to ground.

A bridge amplifier design has a distinct advantage over the single-ended configuration, as it provides differential drive to the load, thus doubling output swing for a specified supply voltage. Consequently, theoretically four times the output power is possible as compared to a single-ended amplifier under the same conditions. This increase in attainable output power assumes that the amplifier is not current limited or clipped.

A direct consequence of the increased power delivered to the load by a bridge amplifier is an increase in internal power dissipation. For each operational amplifier in a bridge configuration, the internal power dissipation will increase by a factor of two over the single ended dissipation. Thus, for an audio power amplifier such as the LM4730, which has two operational amplifiers in one package, the package dissipation will increase by a factor of four. To calculate the LM4730’s maximum power dissipation point for a bridged load, multiply equation (1) by a factor of four.

This value of  $P_{\text{DMAX}}$  can be used to calculate the correct size heat sink for a bridged amplifier application. Since the internal dissipation for a given power supply and load is increased by using bridged-mode, the heatsink’s  $\theta_{\text{SA}}$  will have to decrease accordingly as shown by equation (3). Refer to the section, **Determining the Correct Heat Sink**, for a more detailed discussion of proper heat sinking for a given application.

### SINGLE-SUPPLY AMPLIFIER APPLICATION

The typical application of the LM4730 is a split supply amplifier. But as shown in [Figure 3](#), the LM4730 can also be used in a single power supply configuration. This involves using some external components to create a half-supply bias which is used as the reference for the inputs and outputs. Thus, the signal will swing around half-supply much like it swings around ground in a split-supply application. Along with proper circuit biasing, a few other considerations must be accounted for to take advantage of all of the LM4730 functions.

The LM4730 possesses a mute and standby function with internal logic gates that are half-supply referenced. Thus, to

enable either the Mute or Standby function, the voltage at these pins must be a minimum of 2.5V above half-supply. In single-supply systems, devices such as microprocessors and simple logic circuits used to control the mute and standby functions, are usually referenced to ground, not half-supply. Thus, to use these devices to control the logic circuitry of the LM4730, a “level shifter,” like the one shown in [Figure 5](#), must be employed. A level shifter is not needed in a split-supply configuration since ground is also half-supply.

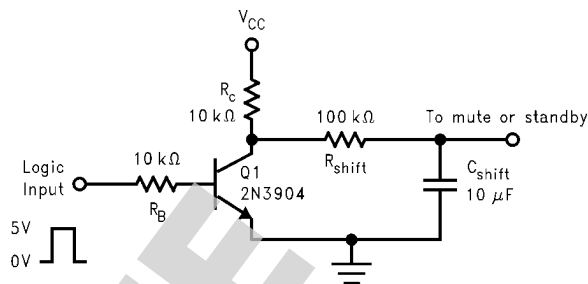

20059412

FIGURE 5. Level Shift Circuit

When the voltage at the Logic Input node is 0V, the 2N3904 is “off” and thus resistor  $R_c$  pulls up mute or standby input to the supply. This enables the mute or standby function. When the Logic Input is 5V, the 2N3904 is “on” and consequently, the voltage at the collector is essentially 0V. This will disable the mute or standby function, and thus the amplifier will be in its normal mode of operation.  $R_{\text{shift}}$ , along with  $C_{\text{shift}}$ , creates an RC time constant that reduces transients when the mute or standby functions are enabled or disabled. Additionally,  $R_{\text{shift}}$  limits the current supplied by the internal logic gates of the LM4730 which insures device reliability. Refer to the Mute Mode and Standby Mode sections in the **Application Information** section for a more detailed description of these functions.

### CLICKS AND POPS

In the typical application of the LM4730 as a split-supply audio power amplifier, the IC exhibits excellent “click” and “pop” performance when utilizing the mute and standby modes. In addition, the device employs Under-Voltage Protection, which eliminates unwanted power-up and power-down transients. The basis for these functions are a stable and constant half-supply potential. In a split-supply application, ground is the stable half-supply potential. But in a single-supply application, the half-supply needs to charge up just like the supply rail,  $V_{\text{CC}}$ . This makes the task of attaining a clickless and popless turn-on more challenging. Any uneven charging of the amplifier inputs will result in output clicks and pops due to the differential input topology of the LM4730.

To achieve a transient free power-up and power-down, the voltage seen at the input terminals should be ideally the same. Such a signal will be common-mode in nature, and will be rejected by the LM4730. In *Figure 3*, the resistor  $R_{INP}$  serves to keep the inputs at the same potential by limiting the voltage difference possible between the two nodes. This should significantly reduce any type of turn-on pop, due to an uneven charging of the amplifier inputs. This charging is based on a specific application loading and thus, the system designer may need to adjust these values for optimal performance.

As shown in *Figure 3*, the resistors labeled  $R_{BI}$  help bias up the LM4730 off the half-supply node at the emitter of the 2N3904. But due to the input and output coupling capacitors in the circuit, along with the negative feedback, there are two different values of  $R_{BI}$ , namely 10 k $\Omega$  and 200 k $\Omega$ . These resistors bring up the inputs at the same rate resulting in a popless turn-on. Adjusting these resistors values slightly may reduce pops resulting from power supplies that ramp extremely quick or exhibit overshoot during system turn-on.

### PROPER SELECTION OF EXTERNAL COMPONENTS

Proper selection of external components is required to meet the design targets of an application. The choice of external component values that will affect gain and low frequency response are discussed below.

The gain of each amplifier is set by resistors  $R_f$  and  $R_i$  for the non-inverting configuration shown in *Figure 1*. The gain is found by Equation (4) below:

$$A_V = 1 + R_f / R_i \text{ (V/V)} \quad (4)$$

For best noise performance, lower values of resistors are used. A value of 1k $\Omega$  is commonly used for  $R_i$  and then setting the value of  $R_f$  for the desired gain. For the LM4730 the gain should be set no lower than 10V/V and no higher than 50V/V. Gain settings below 10V/V may experience instability and using the LM4730 for gains higher than 50V/V will see an increase in noise and THD.

The combination of  $R_i$  with  $C_i$  (see *Figure 1*) creates a high pass filter. The low frequency response is determined by these two components. The -3dB point can be found from Equation (5) shown below:

$$f_i = 1 / (2\pi R_i C_i) \text{ (Hz)} \quad (5)$$

If an input coupling capacitor is used to block DC from the inputs as shown in *Figure 4*, there will be another high pass filter created with the combination of  $C_{IN}$  and  $R_{IN}$ . When using a input coupling capacitor  $R_{IN}$  is needed to set the DC bias point on the amplifier's input terminal. The resulting -3dB frequency response due to the combination of  $C_{IN}$  and  $R_{IN}$  can be found from Equation (6) shown below:

$$f_{IN} = 1 / (2\pi R_{IN} C_{IN}) \text{ (Hz)} \quad (6)$$

### PHYSICAL IC MOUNTING CONSIDERATIONS

Mounting of the TO-220 package to a heat sink must be done such that there is sufficient pressure from the mounting screw to insure good contact with the heat sink for efficient heat flow. Over tightening the mounting screw will cause the TO-220 package to warp reducing contact area with the heat sink. Less contact with the heat sink will increase the thermal resistance from the TO-220 package case to the heat sink ( $\theta_{CS}$ ) resulting in higher operating die temperatures and possible unwanted thermal shut down activation. Extreme over tightening of the mounting screw will cause severe physical stress resulting in cracked die and catastrophic IC failure. The recommended maximum mounting screw torque is 40 inch-lbs or 3.3 foot-lbs (4.5 newton-meter).

Additionally, if the mounting screw is used to force the TO-220 package into correct alignment with the heat sink, package stress will be increased. This increase in package stress will result in reduced contact area with the heat sink increasing die operating temperature and possible catastrophic IC failure.

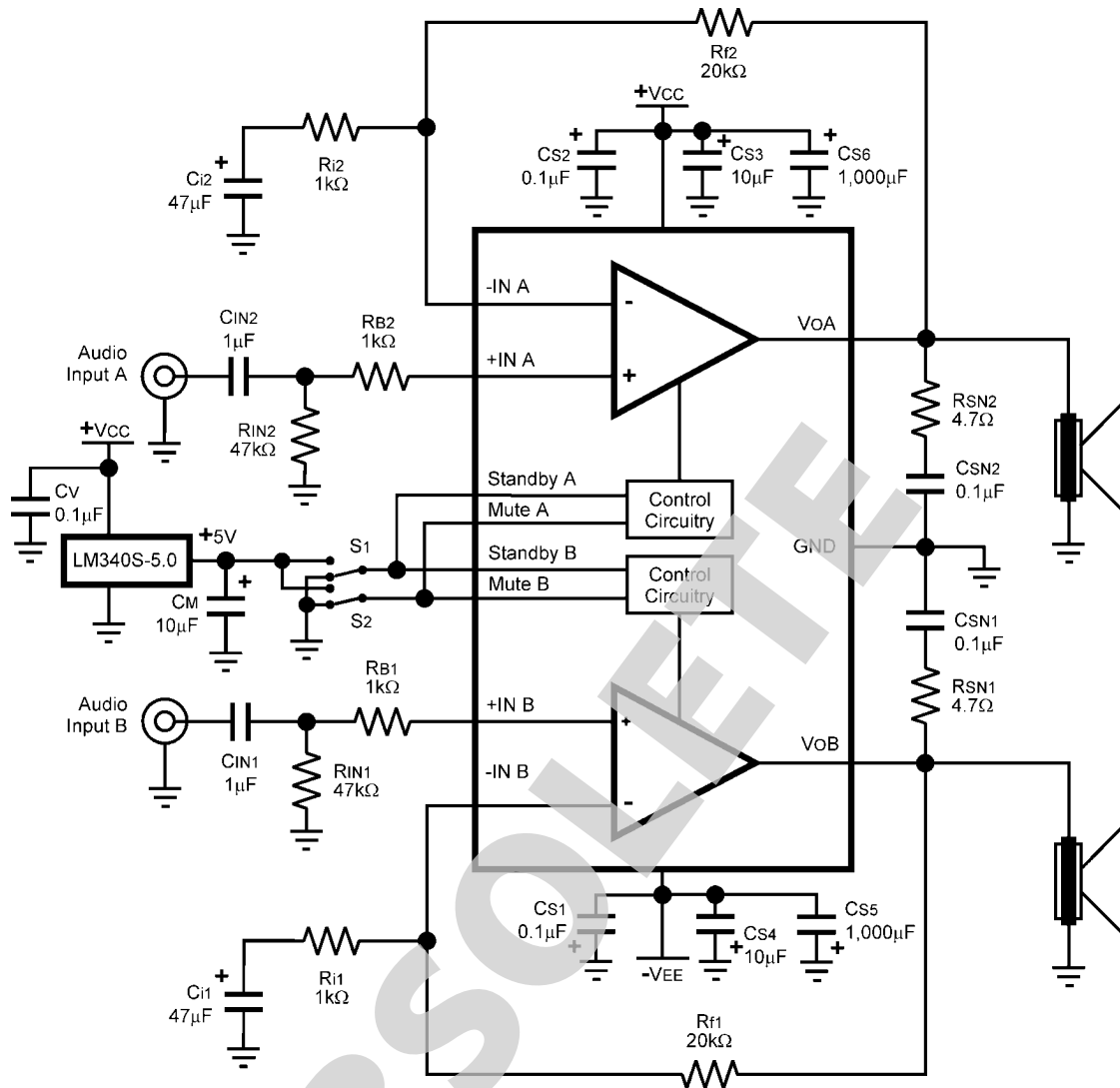

20059458

FIGURE 6. Reference PCB Schematic

LM4730 REFERENCE BOARD ARTWORK

Composite View

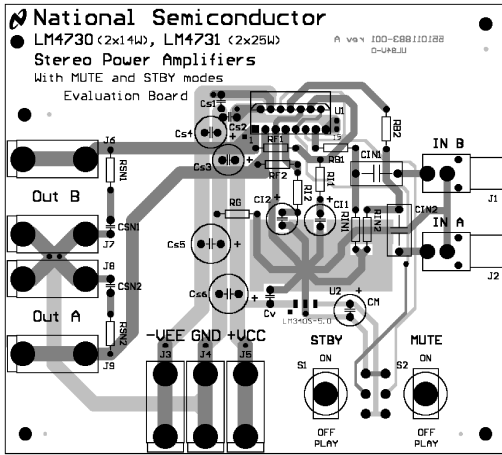

20059454

Silk Screen

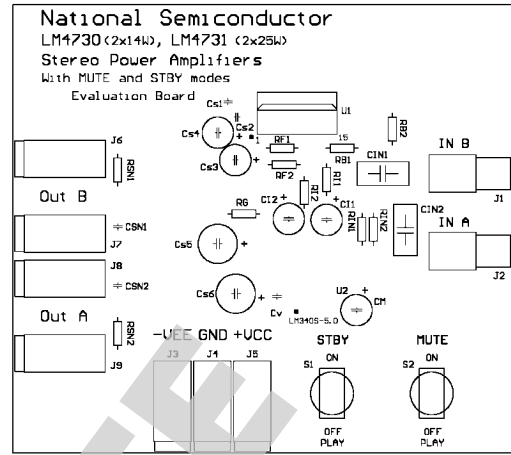

20059455

Top Layer

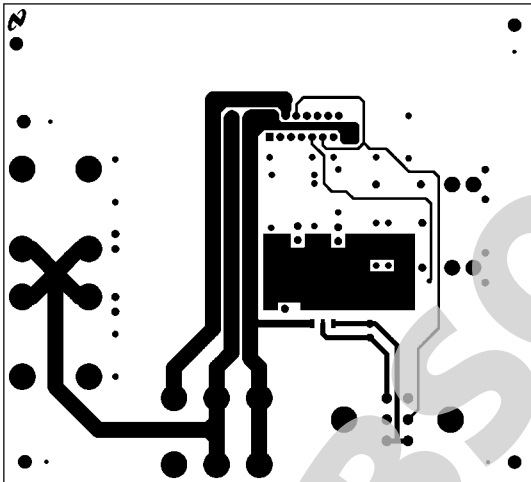

20059456

Bottom Layer

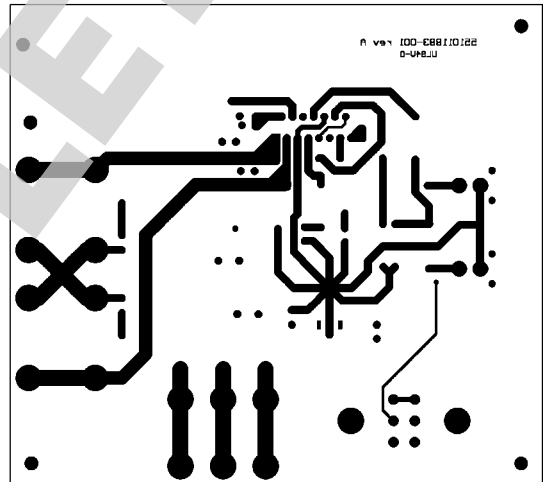

20059457



## BILL OF MATERIALS FOR REFERENCE PCB

Symbol	Value	Tolerance	Type/Description	Comments
$R_{IN1}, R_{IN2}$	47k $\Omega$	5%	1/4 Watt	
$R_{B1}, R_{B2}$	1k $\Omega$	1%	1/4 Watt	
$R_{F1}, R_{F2}$	20k $\Omega$	1%	1/4 Watt	
$R_{i1}, R_{i2}$	1k $\Omega$	1%	1/4 Watt	
$R_{SN1}, R_{SN2}$	4.7 $\Omega$	5%	1/4 Watt	
$R_G$	2.7 $\Omega$	5%	1/4 Watt	
$C_{IN1}, C_{IN2}$	1 $\mu$ F	10%	Metallized Polyester Film	
$C_{i1}, C_{i2}$	47 $\mu$ F	20%	Electrolytic Radial / 35V	
$C_{SN1}, C_{SN2}$	0.1 $\mu$ F	20%	Monolithic Ceramic	
$C_V$	0.1 $\mu$ F	20%	Monolithic Ceramic	
$C_M$	10 $\mu$ F	20%	Electrolytic Radial / 16V	
$C_{S1}, C_{S2}$	0.1 $\mu$ F	20%	Monolithic Ceramic	
$C_{S3}, C_{S4}$	10 $\mu$ F	20%	Electrolytic Radial / 35V	
$C_{S5}, C_{S6}$	1,000 $\mu$ F	20%	Electrolytic Radial / 35V	
$S_1, S_2$			SPDT (on-on) Switch	
$J_1, J_2$			Non-switched PC Mount RCA Jack	
$J_4, J_7, J_8$			PCB Banana Jack- BLACK	
$J_3, J_5, J_6, J_9$			PCB Banana Jack- RED	
$U_1$			15 lead TO-220 Power Socket	
$U_2$			LM340, 5V Fixed Regulator, TO-263 package (TS3B)	

Physical Dimensions inches (millimeters) unless otherwise noted

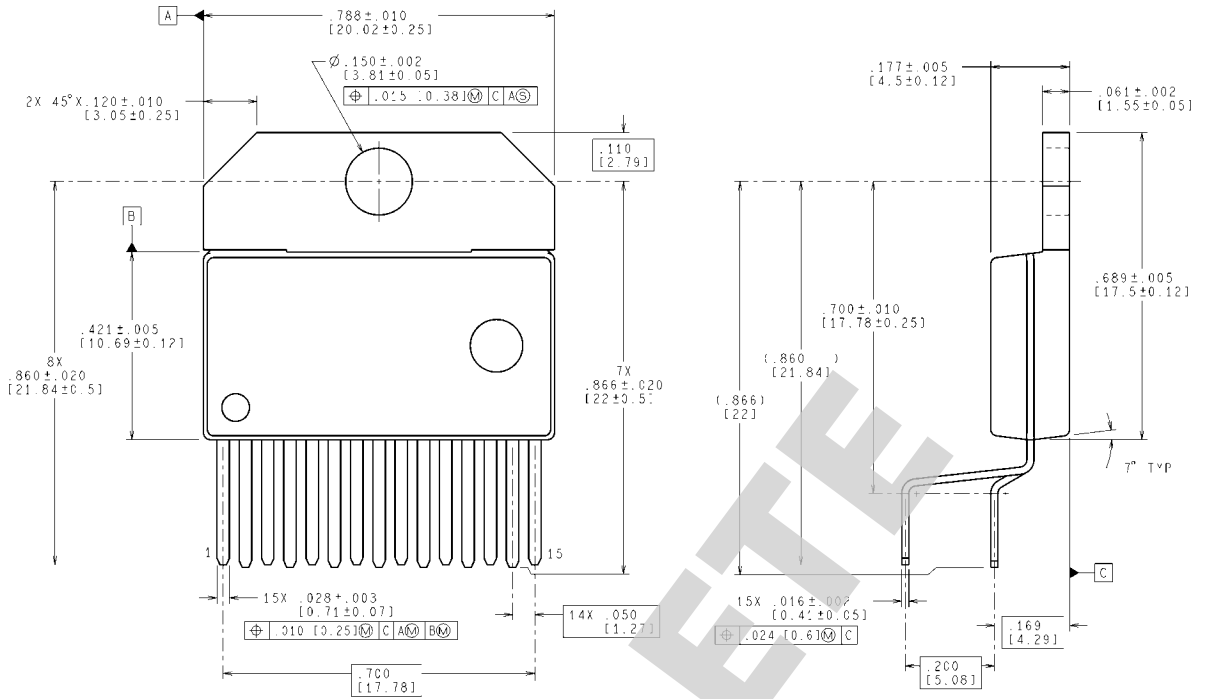

CONTROLLING DIMENSION IS INCH  
VALUES IN [ ] ARE MILLIMETERS

**Non-Isolated TO-220 15-Lead Package**  
**Order Number LM4730TA**  
**NS Package Number TA15A**

TA15A (Rev B)

OBSOLETE

# Notes

LM4730

**OBSOLETE**

## Notes

For more National Semiconductor product information and proven design tools, visit the following Web sites at:

Products		Design Support	
Amplifiers	<a href="http://www.national.com/amplifiers">www.national.com/amplifiers</a>	WEBENCH® Tools	<a href="http://www.national.com/webench">www.national.com/webench</a>
Audio	<a href="http://www.national.com/audio">www.national.com/audio</a>	App Notes	<a href="http://www.national.com/appnotes">www.national.com/appnotes</a>
Clock and Timing	<a href="http://www.national.com/timing">www.national.com/timing</a>	Reference Designs	<a href="http://www.national.com/refdesigns">www.national.com/refdesigns</a>
Data Converters	<a href="http://www.national.com/adc">www.national.com/adc</a>	Samples	<a href="http://www.national.com/samples">www.national.com/samples</a>
Interface	<a href="http://www.national.com/interface">www.national.com/interface</a>	Eval Boards	<a href="http://www.national.com/evalboards">www.national.com/evalboards</a>
LVDS	<a href="http://www.national.com/lvds">www.national.com/lvds</a>	Packaging	<a href="http://www.national.com/packaging">www.national.com/packaging</a>
Power Management	<a href="http://www.national.com/power">www.national.com/power</a>	Green Compliance	<a href="http://www.national.com/quality/green">www.national.com/quality/green</a>
Switching Regulators	<a href="http://www.national.com/switchers">www.national.com/switchers</a>	Distributors	<a href="http://www.national.com/contacts">www.national.com/contacts</a>
LDOs	<a href="http://www.national.com/ldo">www.national.com/ldo</a>	Quality and Reliability	<a href="http://www.national.com/quality">www.national.com/quality</a>
LED Lighting	<a href="http://www.national.com/led">www.national.com/led</a>	Feedback/Support	<a href="http://www.national.com/feedback">www.national.com/feedback</a>
Voltage Reference	<a href="http://www.national.com/vref">www.national.com/vref</a>	Design Made Easy	<a href="http://www.national.com/easy">www.national.com/easy</a>
PowerWise® Solutions	<a href="http://www.national.com/powerwise">www.national.com/powerwise</a>	Solutions	<a href="http://www.national.com/solutions">www.national.com/solutions</a>
Serial Digital Interface (SDI)	<a href="http://www.national.com/sdi">www.national.com/sdi</a>	Mil/Aero	<a href="http://www.national.com/milaero">www.national.com/milaero</a>
Temperature Sensors	<a href="http://www.national.com/tempensors">www.national.com/tempensors</a>	SolarMagic™	<a href="http://www.national.com/solarmagic">www.national.com/solarmagic</a>
Wireless (PLL/VCO)	<a href="http://www.national.com/wireless">www.national.com/wireless</a>	PowerWise® Design University	<a href="http://www.national.com/training">www.national.com/training</a>

THE CONTENTS OF THIS DOCUMENT ARE PROVIDED IN CONNECTION WITH NATIONAL SEMICONDUCTOR CORPORATION ("NATIONAL") PRODUCTS. NATIONAL MAKES NO REPRESENTATIONS OR WARRANTIES WITH RESPECT TO THE ACCURACY OR COMPLETENESS OF THE CONTENTS OF THIS PUBLICATION AND RESERVES THE RIGHT TO MAKE CHANGES TO SPECIFICATIONS AND PRODUCT DESCRIPTIONS AT ANY TIME WITHOUT NOTICE. NO LICENSE, WHETHER EXPRESS, IMPLIED, ARISING BY ESTOPPEL OR OTHERWISE, TO ANY INTELLECTUAL PROPERTY RIGHTS IS GRANTED BY THIS DOCUMENT.

TESTING AND OTHER QUALITY CONTROLS ARE USED TO THE EXTENT NATIONAL DEEMS NECESSARY TO SUPPORT NATIONAL'S PRODUCT WARRANTY. EXCEPT WHERE MANDATED BY GOVERNMENT REQUIREMENTS, TESTING OF ALL PARAMETERS OF EACH PRODUCT IS NOT NECESSARILY PERFORMED. NATIONAL ASSUMES NO LIABILITY FOR APPLICATIONS ASSISTANCE OR BUYER PRODUCT DESIGN. BUYERS ARE RESPONSIBLE FOR THEIR PRODUCTS AND APPLICATIONS USING NATIONAL COMPONENTS. PRIOR TO USING OR DISTRIBUTING ANY PRODUCTS THAT INCLUDE NATIONAL COMPONENTS, BUYERS SHOULD PROVIDE ADEQUATE DESIGN, TESTING AND OPERATING SAFEGUARDS.

EXCEPT AS PROVIDED IN NATIONAL'S TERMS AND CONDITIONS OF SALE FOR SUCH PRODUCTS, NATIONAL ASSUMES NO LIABILITY WHATSOEVER, AND NATIONAL DISCLAIMS ANY EXPRESS OR IMPLIED WARRANTY RELATING TO THE SALE AND/OR USE OF NATIONAL PRODUCTS INCLUDING LIABILITY OR WARRANTIES RELATING TO FITNESS FOR A PARTICULAR PURPOSE, MERCHANTABILITY, OR INFRINGEMENT OF ANY PATENT, COPYRIGHT OR OTHER INTELLECTUAL PROPERTY RIGHT.

#### LIFE SUPPORT POLICY

**NATIONAL'S PRODUCTS ARE NOT AUTHORIZED FOR USE AS CRITICAL COMPONENTS IN LIFE SUPPORT DEVICES OR SYSTEMS WITHOUT THE EXPRESS PRIOR WRITTEN APPROVAL OF THE CHIEF EXECUTIVE OFFICER AND GENERAL COUNSEL OF NATIONAL SEMICONDUCTOR CORPORATION.** As used herein:

Life support devices or systems are devices which (a) are intended for surgical implant into the body, or (b) support or sustain life and whose failure to perform when properly used in accordance with instructions for use provided in the labeling can be reasonably expected to result in a significant injury to the user. A critical component is any component in a life support device or system whose failure to perform can be reasonably expected to cause the failure of the life support device or system or to affect its safety or effectiveness.

National Semiconductor and the National Semiconductor logo are registered trademarks of National Semiconductor Corporation. All other brand or product names may be trademarks or registered trademarks of their respective holders.

Copyright© 2009 National Semiconductor Corporation

For the most current product information visit us at [www.national.com](http://www.national.com)

 **National Semiconductor Americas Technical Support Center**  
Email: [support@nsc.com](mailto:support@nsc.com)  
Tel: 1-800-272-9959

**National Semiconductor Europe Technical Support Center**  
Email: [europe.support@nsc.com](mailto:europe.support@nsc.com)

**National Semiconductor Asia Pacific Technical Support Center**  
Email: [ap.support@nsc.com](mailto:ap.support@nsc.com)

**National Semiconductor Japan Technical Support Center**  
Email: [jpn.feedback@nsc.com](mailto:jpn.feedback@nsc.com)