

Enhanced Plastic High Voltage (80V) Step Down Switching Regulator

General Description

The LM5007EP Step Down Switching Regulator features all of the functions needed to implement low cost, efficient, Buck bias regulators. This high voltage regulator contains an 80 V, 0.7A N-Channel Buck Switch. The device is easy to apply and is provided in the MSOP-8 and the thermally enhanced LLP-8 packages. The regulator is based on a hysteretic control scheme using an on time inversely proportional to V_{IN} . This feature allows the operating frequency to remain relatively constant with load and input voltage variations. The hysteretic control requires no control loop compensation, while providing very fast load transient response. An intelligent current limit is implemented in the LM5007EP with forced off time that is inversely proportional to V_{OUT} . This current limiting scheme reduces load current foldback. Additional protection features include: Thermal Shutdown, Vcc undervoltage lockout, gate drive undervoltage lockout, and Max Duty Cycle limiter.

ENHANCED PLASTIC

- Extended Temperature Performance of -40°C to $+125^{\circ}\text{C}$
- Baseline Control - Single Fab & Assembly Site
- Process Change Notification (PCN)
- Qualification & Reliability Data
- Solder (PbSn) Lead Finish is standard
- Enhanced Diminishing Manufacturing Sources (DMS) Support

Features

- Integrated 80V, 0.7A N-Channel Buck Switch
- Internal HV Vcc Regulator
- No Control Loop Compensation Required
- Ultra-Fast Transient Response
- On Time Varies Inversely with Line Voltage
- Operating Frequency Nearly Constant with Varying Line Voltage
- Adjustable Output Voltage
- Highly Efficient Operation
- Precision Reference
- Low Bias Current
- Intelligent Current Limit Protection
- Thermal Shutdown
- External Shutdown Control

Typical Applications

- Non-Isolated Buck Regulator
- Secondary High Voltage Post Regulator
- Selected Military Applications
- Selected Avionics Applications

Ordering Information

Part Number	VID Part Number	NS Package Number (Note 3)
LM5007MMEP	V62/04633-01	MUA08A
(Note 1, Note 2)	TBD	TBD

Note 1: For the following (Enhanced Plastic) versions, check for availability: LM5007MMXEP, LM5007SDEP, LM5007SDXEP

Note 2: FOR ADDITIONAL ORDERING AND PRODUCT INFORMATION, PLEASE VISIT THE ENHANCED PLASTIC WEB SITE AT: www.national.com/mil

Note 3: Refer to package details under Physical Dimensions

Connection Diagram

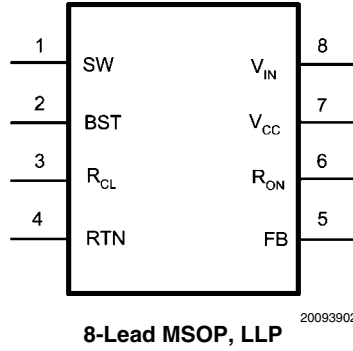

Typical Application Circuit and Block Diagram

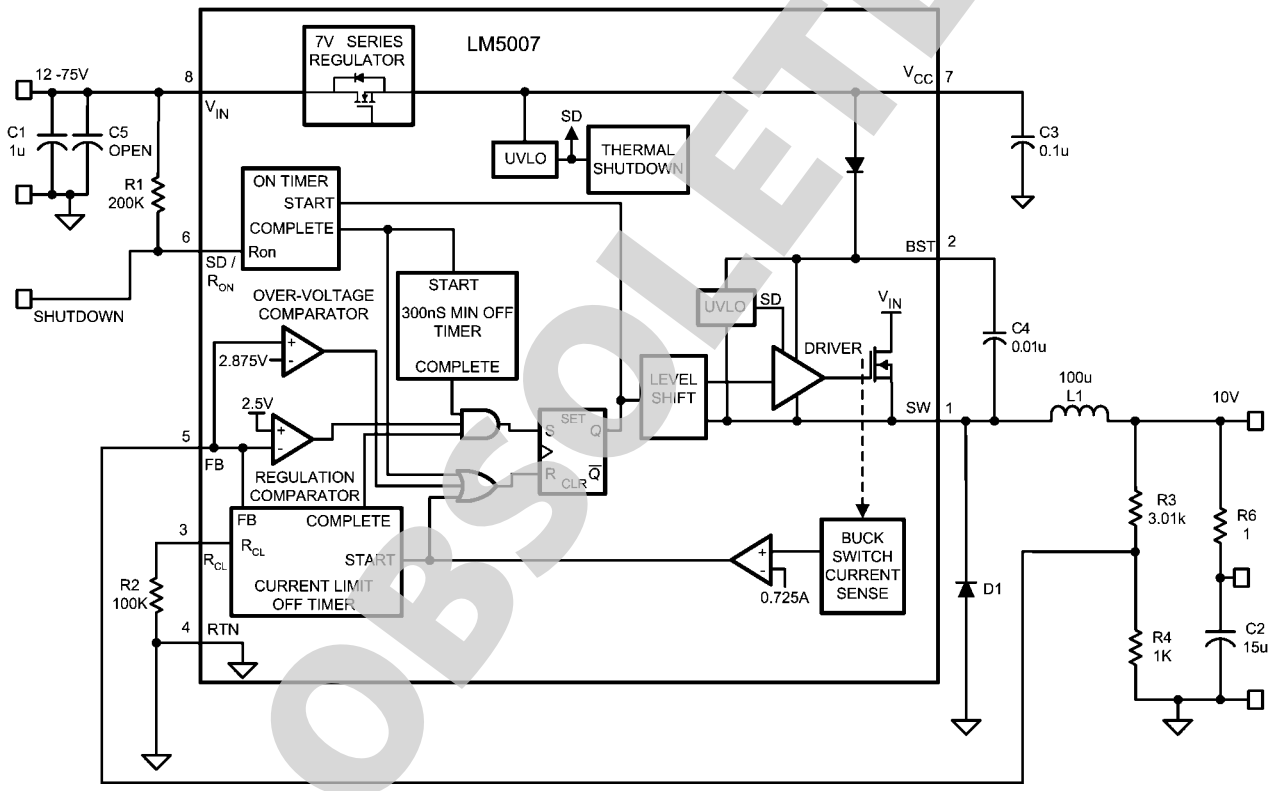

Pin Descriptions

Pin	Name	Description	Application Information
1	SW	Switching Node	Power switching node. Connect to the LC output filter.
2	BST	Boost Boot-strap capacitor input	An external capacitor is required between the BST and the SW pins. A 0.01 μ F ceramic capacitor is recommended. An internal diode between Vcc and BST completes the Buck gate drive bias network.
3	R _{CL}	Current Limit OFF time programming pin T _{off} = $10^{-5} / (0.59 + (FB / 7.22 \times 10^{-6} \times R_{CL}))$	A resistor between this pin and RTN determines the variation of off time, along with the FB pin voltage, per cycle while in current limit. The off time is preset to 17 μ S if FB = 0V and decreases as the FB pin voltage increases.
4	RTN	Circuit Ground	
5	FB	Feedback Signal from Regulated Output	This pin is connected to the inverting input of the internal regulation comparator. The regulation threshold is 2.5V.
6	R _{ON}	On time set pin T _{on} = $1.42 \times 10^{-10} R_{ON} / V_{in}$	A resistor between this pin and V _{in} sets the switch on time as a function of V _{in} . The minimum recommended on time is 300ns at the maximum input voltage.
7	Vcc	Output from the internal high voltage bias regulator. V _{CC} is nominally regulated to 7 Volts.	If an auxiliary voltage is available to raise the voltage on this pin, above the regulation setpoint (7V), the internal series pass regulator will shutdown, reducing the IC power dissipation. Do not exceed 14V. This output provides gate drive power for the internal Buck switch. An internal diode is provided between this pin and the BST pin. A local 0.1 μ F decoupling capacitor is recommended. Series pass regulator is current limited to 10mA.
8	Vin	Input supply voltage	Recommended operating range: 9V to 75V

Absolute Maximum Ratings (Note 4)

If Military/Aerospace specified devices are required, please contact the National Semiconductor Sales Office/Distributors for availability and specifications.

V_{IN} to GND	80V
BST to GND	94V
SW to GND (Steady State)	-1V
ESD Rating (Note 8)	
Human Body Model	2kV
Machine Model	200V

BST to V_{CC}	80V
BST to SW	14V
V_{CC} to GND	14V
All Other Inputs to GND	-0.3 to 7V
Lead Temperature (Soldering 4 sec)	260°C
Storage Temperature Range	-55°C to +150°C

Operating Ratings (Note 4)

V_{IN}	9V to 75V
Junction Temperature	-40°C to +125°C

Electrical Characteristics

Specifications with standard typeface are for $T_J = 25^\circ\text{C}$, and those with **boldface** type apply over full **Operating Junction Temperature range**. $V_{IN} = 48\text{V}$, unless otherwise stated (Note 6).

Symbol	Parameter	Conditions	Min	Typ	Max	Units
Startup Regulator						
V_{CC} Reg	V_{CC} Regulator Output		6.6	7	7.4	V
	V_{CC} Current Limit	(Note 7)		11		mA
V_{CC} Supply						
	V_{CC} undervoltage Lockout Voltage (V_{CC} increasing)			6.3		V
	V_{CC} Undervoltage Hysteresis			206		mV
	V_{CC} UVLO Delay (filter)			3		μs
	Operating Current (ICC)	Non-Switching, FB = 3V		500	675	μA
	Shutdown/Standby Current	$R_{ON} = 0\text{V}$		100	200	μA
Switch Characteristics						
	Buck Switch $R_{ds(on)}$	$I_{TEST} = 200\text{mA}$, $V_{BST} - V_{SW} = 6.3\text{V}$ (Note 9)		0.74	1.34	Ω
	Gate Drive UVLO ($V_{BST} - V_{SW}$)	Rising	3.4	4.5	5.5	V
	Gate Drive UVLO Hysteresis			400		mV
	Breakdown Voltage V_{IN} to Ground	$T_J = 25^\circ\text{C}$ $T_J = -40^\circ\text{C}$ to $+125^\circ\text{C}$	80 76			V
	Breakdown Voltage BST to V_{CC}	$T_J = 25^\circ\text{C}$ $T_J = -40^\circ\text{C}$ to $+125^\circ\text{C}$	80 76			V
Current Limit						
	Current Limit Threshold		535	725	900	mA
	Current Limit Response Time	I_{switch} Overdrive = 0.1A Time to Switch Off		225		ns
	OFF time generator (test 1)	FB=0V, RCL = 100K		17		μs
	OFF time generator (test 2)	FB=2.3V, RCL = 100K		2.65		μs
On Time Generator						
	TON -1	$V_{in} = 10\text{V}$ $R_{ON} = 200\text{K}$	2.15	2.77	3.5	μs
	TON -2	$V_{in} = 75\text{V}$ $R_{ON} = 200\text{K}$	290	390	490	ns
	Remote Shutdown Threshold	Rising	0.45	0.7	1.1	V
	Remote Shutdown Hysteresis			40		mV

Symbol	Parameter	Conditions	Min	Typ	Max	Units
Minimum Off Time						
	Minimum Off Timer	FB = 0V		300		ns
Regulation and OV Comparators						
	FB Reference Threshold	Internal reference Trip point for switch ON	2.445	2.5	2.550	V
	FB Over-Voltage Threshold	Trip point for switch OFF		2.875		V
	FB Bias Current			100		nA
Thermal Shutdown						
Tsd	Thermal Shutdown Temp.			165		°C
	Thermal Shutdown Hysteresis			25		°C
Thermal Resistance						
θ_{JA}	Junction to Ambient	MUA Package		200		°C/W
		SDC Package		40		°C/W

Note 4: Absolute Maximum Ratings are limits beyond which damage to the device may occur. Operating Ratings are conditions under which operation of the device is intended to be functional. For guaranteed specifications and test conditions, see the Electrical Characteristics.

Note 5: For detailed information on soldering plastic MSOP and LLP packages, refer to the Packaging Data Book available from National Semiconductor Corporation.

Note 6: All limits are guaranteed. All electrical characteristics having room temperature limits are tested during production with $T_A = T_J = 25^\circ\text{C}$. All hot and cold limits are guaranteed by correlating the electrical characteristics to process and temperature variations and applying statistical process control.

Note 7: The V_{CC} output is intended as a self bias for the internal gate drive power and control circuits. Device thermal limitations limit external loading.

Note 8: The human body model is a 100pF capacitor discharge through a 1.5k Ω resistor into each pin. The machine model is a 200pF capacitor discharged directly into each pin. The machine model ESD compliance level for Pin 5 is 150V. The human body ESD compliance level for Pin 7 and 8 is 1000V.

Note 9: For devices procured in the LLP-8 package the $R_{ds(on)}$ limits are guaranteed by design characterization data only.

Detailed Operating Description

The LM5007EP Step Down Switching Regulator features all of the functions needed to implement low cost, efficient, Buck bias regulators. This high voltage regulator contains an 80V, 0.7A N-Channel Buck Switch. The device is easy to apply and is provided in the MSOP-8 and the thermally enhanced LLP-8 packages. The regulator is based on a hysteretic control scheme using an on time inversely proportional to V_{in} . This feature allows the operating frequency to remain relatively constant with load and input voltage variations. The hysteretic control requires no control loop compensation, while providing very fast load transient response. An intelligent current limit scheme is implemented in the LM5007EP with forced off time, after current limit detection, which is inversely proportional to V_{out} . This current limiting scheme reduces load current foldback. Additional protection features include: Thermal Shutdown, V_{cc} undervoltage lockout, Gate drive undervoltage lockout and Max Duty Cycle limiter. The LM5007EP can be applied in numerous applications to efficiently regulate step down higher voltage inputs. This regulator is well suited for 48 Volt Telcom and the new 42V Automotive power bus ranges.

Hysteretic Control Circuit Overview

The LM5007EP is a Buck DC-DC regulator that uses an on time control scheme. The on time is programmed by an external resistor and varies inversely with line input voltage (V_{in}). The core regulation elements of the LM5007EP are the feedback comparator and the on time one-shot. The regulator output voltage is sensed at the feedback pin (FB) and is compared to an internal reference voltage (2.5V). If the FB signal is below the reference voltage, the buck switch is turned on for a fixed time pulse determined by the line voltage and a programming resistor (R_{ON}). Following the on period the switch will remain off for at least the minimum off timer period of 300ns. If the FB pin voltage is still below the reference after

the 300ns off time, the switch will turn on again for another on time period. This switching behavior will continue until the FB pin voltage reaches the reference voltage level.

The LM5007EP operates in discontinuous conduction mode at light load currents or continuous conduction mode at heavier load currents. In discontinuous conduction mode, current through the output inductor starts at zero and ramps up to a peak value during the buck switch on time and then back to zero during the off time. The inductor current remains at zero until the next on time period starts when FB falls below the internal reference. In discontinuous mode the operating frequency can be relatively low and will vary with load. Therefore at light loads the conversion efficiency is maintained, since the switching losses decrease with the reduction in load current and switching frequency. The approximate discontinuous mode operating frequency can be calculated as follows:

$$F = \frac{V_{OUT}^2 \times L}{1 \times 10^{-20} \times R_{Load} \times (R_{ON})^2}$$

In continuous conduction mode, current flows continuously through the inductor and never ramps down to zero. In this mode the operating frequency is greater than the discontinuous mode frequency and remains relatively constant with load and line variations. The approximate continuous mode operating frequency can be calculated as follows:

$$F = \frac{V_{OUT}}{1.42 \times 10^{-10} \times R_{ON}}$$

The output voltage (V_{out}) can be programmed by two external resistors as shown in [Figure 1](#). The regulation point can be calculated as follows:

$$V_{OUT} = 2.5 \times (R1 + R2) / R2$$

The feedback comparator in hysteretic regulators depend upon the output ripple voltage to switch the output transistor on and off at regular intervals. In order for the internal comparator to respond quickly to changes in output voltage, proportional to inductor current, a minimum amount of capacitor Equivalent Series Resistance (ESR) is required. A ripple voltage of 25mV to 50mV is recommended at the feedback pin (FB) for stable operation. In cases where the intrinsic capacitor ESR is too small, additional series resistance may be added.

For applications where lower output voltage ripple is required the load can be connected directly to the low ESR output capacitor, as shown in *Figure 1*. The series resistor (R) will degrade the load regulation. Another technique for enhancing the ripple voltage at the FB pin is to place a capacitor in parallel with the feedback divider resistor R1. The addition of the capacitor reduces the attenuation of the ripple voltage from the feedback divider

High Voltage Bias Regulator

The LM5007EP contains an internal high voltage bias regulator. The input pin (V_{IN}) can be connected directly to line voltages from 9 to 75 Volts. The regulator is internally current limited to 10mA. Upon power up, the regulator is enabled and sources current into an external capacitor connected to the V_{CC} pin. When the voltage on the V_{CC} pin reaches the regulation point of 7V, the controller output is enabled.

An external auxiliary supply voltage can be applied to the V_{CC} pin. If the auxiliary voltage is greater than 7 Volts the internal regulator will essentially shutoff, thus reducing internal power dissipation.

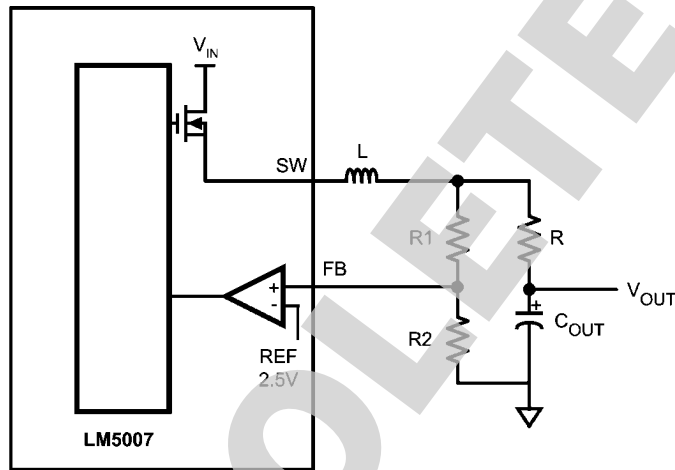

20093905

FIGURE 1. Low Ripple Output Configuration

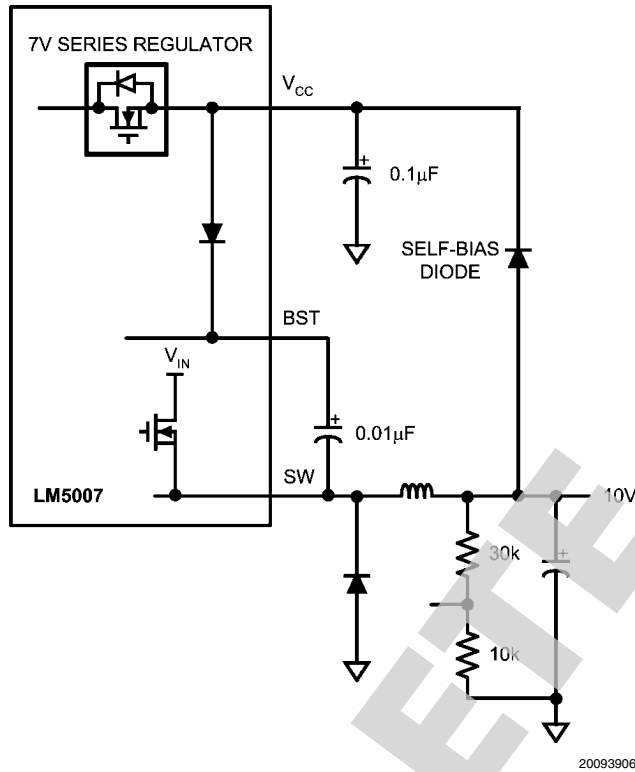

FIGURE 2. Self Biased Configuration

Over-Voltage Comparator

The over-voltage comparator is provided to protect the output from overvoltage conditions due to sudden input line voltage changes or output loading changes. The over-voltage comparator monitors the FB pin versus an internal 2.875V reference (OV_REF). If the voltage at FB rises above OV_REF the comparator immediately terminates the buck switch on time pulse.

On Time Generator and Shutdown

The on time of the LM5007EP is set inversely proportional to the input voltage by an external resistor connected between R_{ON} and Vin. The R_{ON} terminal is a low impedance input biased at approximately 1.5V. Thus the current through the

resistor and into the R_{ON} terminal is approximately proportional to Vin and used internally to control the on timer. This scheme of input voltage feed-forward hysteretic operation achieves nearly constant operational frequency over varying line and load conditions. The on time equation for the LM5007EP is :

$$T_{on} = 1.42 \times 10^{-10} \times R_{ON} / V_{IN}$$

The R_{ON} pin of the LM5007EP also provides a shutdown function which disables the regulator and significantly decreases quiescent power dissipation. By pulling the R_{ON} pin to below 0.7V logic threshold activates the low power shutdown mode. The V_{IN} quiescent current in the shutdown mode is approximately 100µA internal to the LM5007EP plus the current in the R_{ON} resistor.

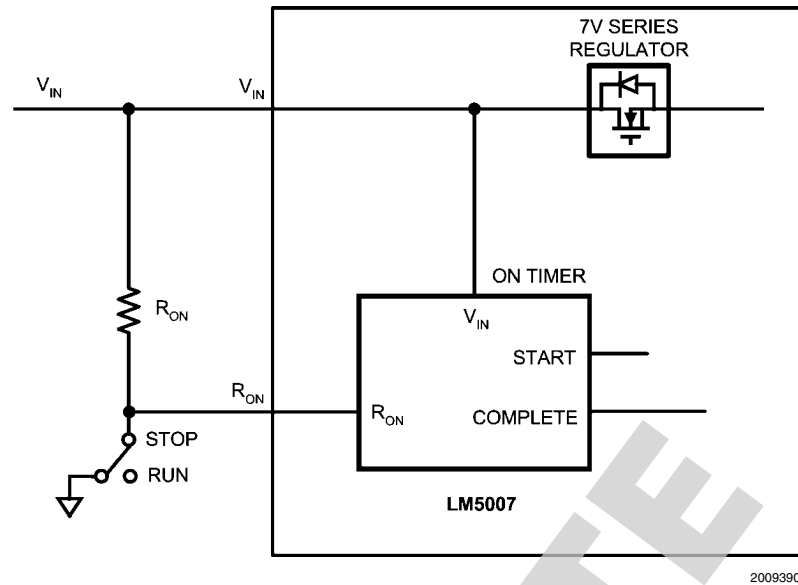

FIGURE 3. Shutdown Implementation

Current Limit

The LM5007EP contains an intelligent current limit off timer intended to reduce the foldback characteristic inherent with fixed off-time over-current protection. If the current in the Buck switch exceeds 725mA the present cycle on time is immediately terminated (cycle by cycle current limit). Following the termination of the cycle a non-resettable current limit off timer is initiated. The duration of the off time is a function of the external resistor (R_{CI}) and the FB pin voltage. When the FB pin voltage equals zero, the current limit off time is internally preset to 17 μ S. This condition occurs in short circuit operation when a maximum amount of off time is required.

In cases of overload (not complete short circuit) the current limit off time can be reduced as a function of the output voltage (measured at the FB pin). Reducing the off time with smaller overloads reduces the amount of foldback and also reduces the initial start-up time. The current limit off time for a given FB pin voltage and R_{CI} resistor can be calculated by the following equation:

$$T_{off} = 10^{-5} / (0.59 + (V_{FB} / 7.22 \times 10^{-6} \times R_{CL}))$$

Applications utilizing low resistance inductors and/or a low voltage drop rectifier may require special evaluation at high line, short circuit conditions. In this special case the preset 17 μ S (FB = 0V) off time may be insufficient to balance the inductor volt*time product. Additional inductor resistance, output resistance or a larger voltage drop rectifier may be necessary to balance the inductor cycle volt*time product and limit the short circuit current.

N - Channel Buck Switch and Driver

The LM5007EP integrates an N-Channel Buck switch and associated floating high voltage gate driver. This gate driver

circuit works in conjunction with an external bootstrap capacitor and an internal high voltage diode. The bootstrap capacitor is charged by V_{CC} through the internal high voltage diode. A 0.01 μ F ceramic capacitor connected between the BST pin and SW pin is recommended.

During each cycle when the Buck switch turns off, the SW pin is approximately 0V. When the SW pin voltage is low, the bootstrap capacitor will be charged from V_{CC} through the internal diode. The minimum off timer, set to 300ns, ensures that there will be a minimum interval every cycle to recharge the bootstrap capacitor.

An external re-circulating diode from the SW pin to ground is necessary to carry the inductor current after the internal Buck switch turns off. This external diode must be of the Ultra-fast or Schottky type to reduce turn-on losses and current overshoot. The reverse voltage rating of the re-circulating diode must be greater than the maximum line input voltage.

Thermal Protection

Internal Thermal Shutdown circuitry is provided to protect the integrated circuit in the event the maximum junction temperature is exceeded. When thermal protection is activated, typically at 165 degrees Celsius, the controller is forced into a low power reset state, disabling the output driver. This feature is provided to prevent catastrophic failures from accidental device overheating.

Typical Performance Characteristics

Operational Waveforms

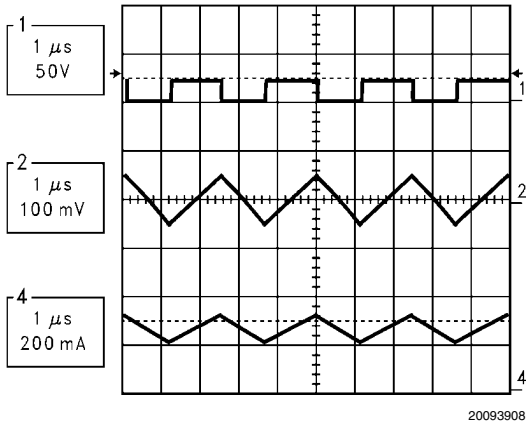

20093908

LM5007EP Operation: $V_{OUT} = 10V$, $V_{IN} = 20V$, $I_{OUT} = 250mA$
 CH1: Switch Node, CH2: V_{OUT} (AC), CH4: Inductor Current

FIGURE 4.

LM5007EP 10V Output Efficiency

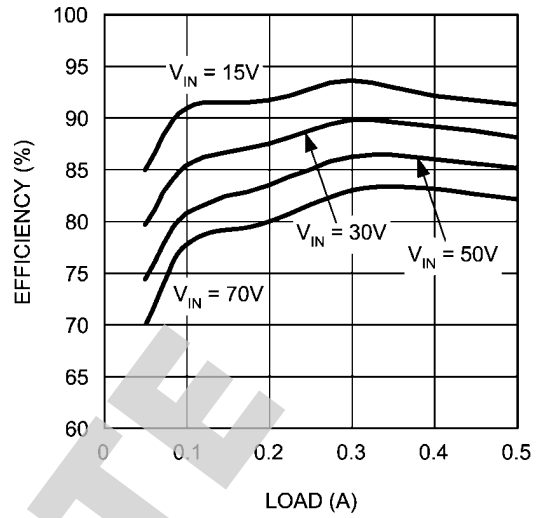

20093910

FIGURE 6.

Operational Waveforms

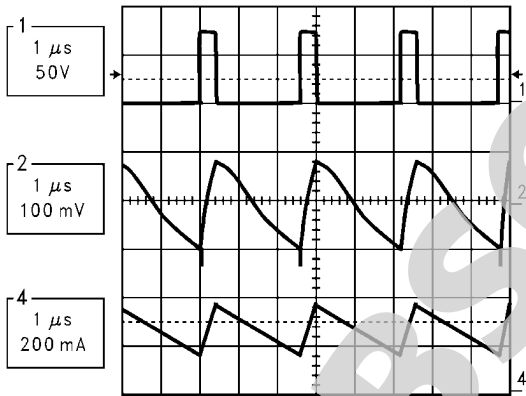

20093909

LM5007EP Operation: $V_{OUT} = 10V$, $V_{IN} = 75V$, $I_{OUT} = 250mA$
 CH1: Switch Node, CH2: V_{OUT} (AC), CH4: Inductor Current

FIGURE 5.

Current Limit V_{FB} vs T_{OFF}
 $R_{CL} = 50k - 600k$

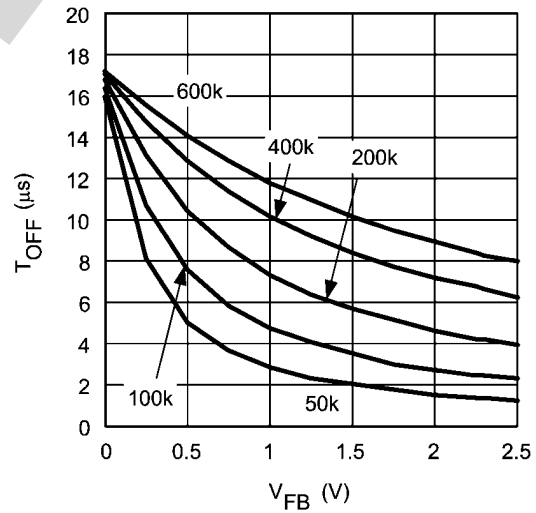

20093911

FIGURE 7.

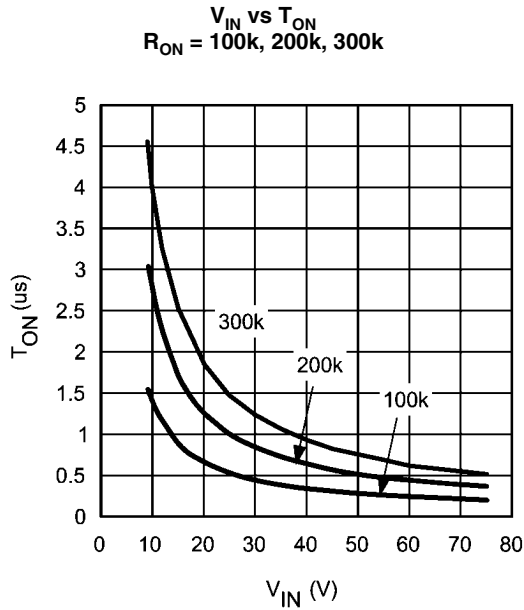

20093912

FIGURE 8.

10V, 400mA Demo Board Bill of Materials

Item	Part Number	Description	Value
C1	C4532X7R2A105M	CAPACITOR, CER, TDK	1μ, 100V
C2	C4532X7R1E156M	CAPACITOR, CER, TDK	15μ, 25V
C3	C1206C104K5RAC	CAPACITOR, CER, KEMET	0.1μ, 50V
C4	C1206C103K5RAC	CAPACITOR, CER, KEMET	0.01μ, 50V
C5	OPEN	UNUSED	
D1	MURA110T3	DIODE, 100V, ON SEMI	
L1	SLF7045T-101MR60-1	BUCK INDUCTOR, TDK	100μH
R1	CRCW12062003F	RESISTOR	200K
R2	CRCW12061003F	RESISTOR	100K
R3	CRCW12063011F	RESISTOR	3.01K
R4	CRCW12061001F	RESISTOR	1K
R5	CRCW12061R00F	RESISTOR	1
U1	LM5007	REGULATOR, NATIONAL	

Physical Dimensions inches (millimeters) unless otherwise noted

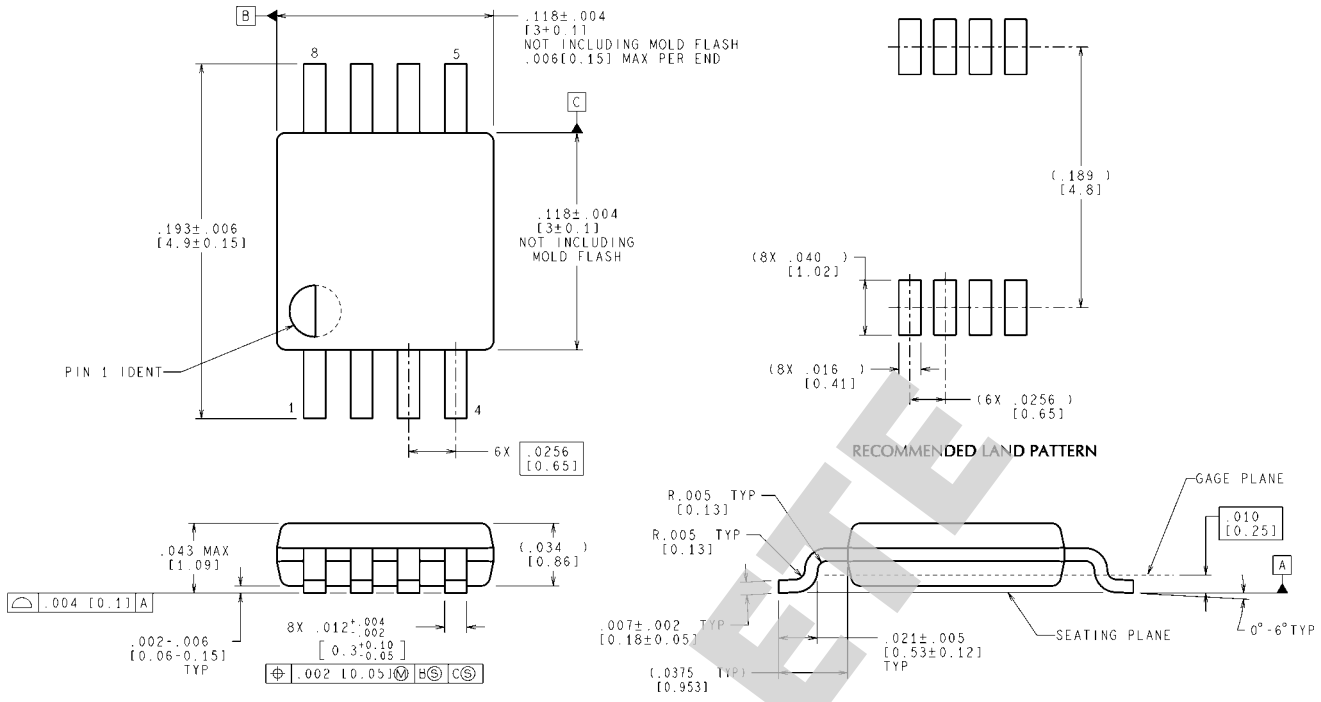

CONTROLLING DIMENSION IS INCH
VALUES IN [] ARE MILLIMETERS

MUA08A (Rev F)

8-Lead MSOP Package
NS Package Number MUA08A

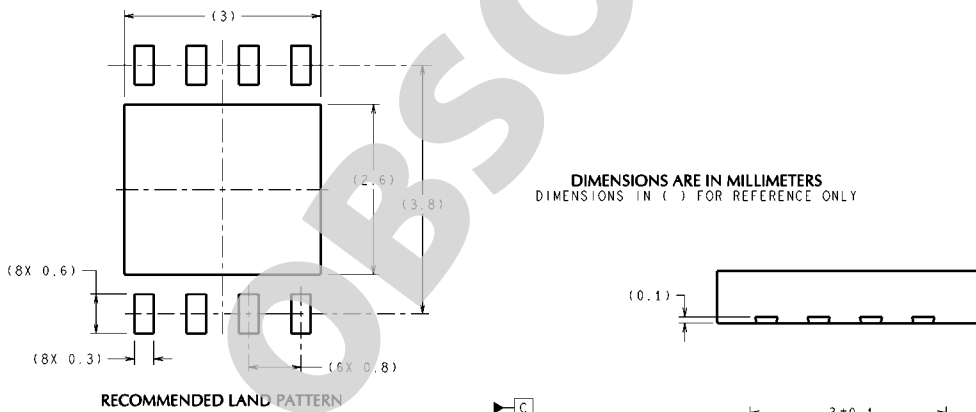

DIMENSIONS ARE IN MILLIMETERS
DIMENSIONS IN () FOR REFERENCE ONLY

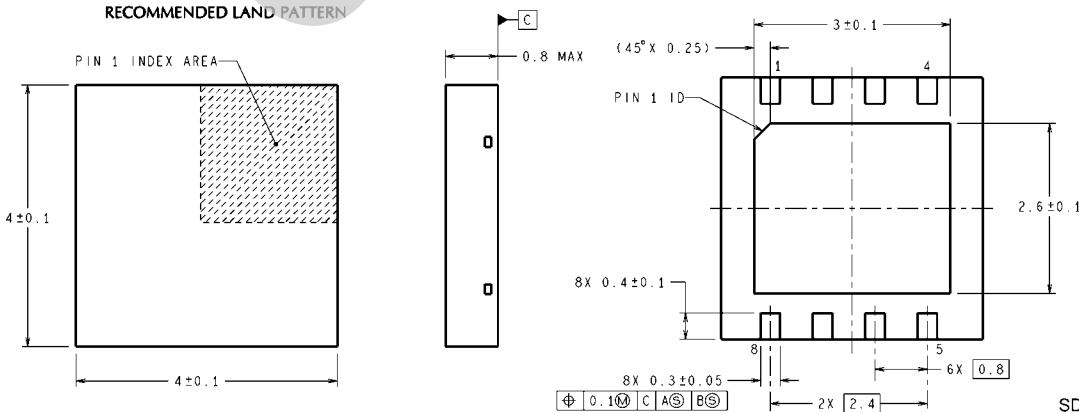

8-Lead LLP Package (4mm x 4mm)
NS Package Number SDC08A

SDC08A (Rev A)

For more National Semiconductor product information and proven design tools, visit the following Web sites at:
www.national.com

Products		Design Support	
Amplifiers	www.national.com/amplifiers	WEBENCH® Tools	www.national.com/webench
Audio	www.national.com/audio	App Notes	www.national.com/appnotes
Clock and Timing	www.national.com/timing	Reference Designs	www.national.com/refdesigns
Data Converters	www.national.com/adc	Samples	www.national.com/samples
Interface	www.national.com/interface	Eval Boards	www.national.com/evalboards
LVDS	www.national.com/lvds	Packaging	www.national.com/packaging
Power Management	www.national.com/power	Green Compliance	www.national.com/quality/green
Switching Regulators	www.national.com/switchers	Distributors	www.national.com/contacts
LDOs	www.national.com/ldo	Quality and Reliability	www.national.com/quality
LED Lighting	www.national.com/led	Feedback/Support	www.national.com/feedback
Voltage References	www.national.com/vref	Design Made Easy	www.national.com/easy
PowerWise® Solutions	www.national.com/powerwise	Applications & Markets	www.national.com/solutions
Serial Digital Interface (SDI)	www.national.com/sdi	Mil/Aero	www.national.com/milaero
Temperature Sensors	www.national.com/tempensors	SolarMagic™	www.national.com/solarmagic
PLL/VCO	www.national.com/wireless	PowerWise® Design University	www.national.com/training

THE CONTENTS OF THIS DOCUMENT ARE PROVIDED IN CONNECTION WITH NATIONAL SEMICONDUCTOR CORPORATION ("NATIONAL") PRODUCTS. NATIONAL MAKES NO REPRESENTATIONS OR WARRANTIES WITH RESPECT TO THE ACCURACY OR COMPLETENESS OF THE CONTENTS OF THIS PUBLICATION AND RESERVES THE RIGHT TO MAKE CHANGES TO SPECIFICATIONS AND PRODUCT DESCRIPTIONS AT ANY TIME WITHOUT NOTICE. NO LICENSE, WHETHER EXPRESS, IMPLIED, ARISING BY ESTOPPEL OR OTHERWISE, TO ANY INTELLECTUAL PROPERTY RIGHTS IS GRANTED BY THIS DOCUMENT.

TESTING AND OTHER QUALITY CONTROLS ARE USED TO THE EXTENT NATIONAL DEEMS NECESSARY TO SUPPORT NATIONAL'S PRODUCT WARRANTY. EXCEPT WHERE MANDATED BY GOVERNMENT REQUIREMENTS, TESTING OF ALL PARAMETERS OF EACH PRODUCT IS NOT NECESSARILY PERFORMED. NATIONAL ASSUMES NO LIABILITY FOR APPLICATIONS ASSISTANCE OR BUYER PRODUCT DESIGN. BUYERS ARE RESPONSIBLE FOR THEIR PRODUCTS AND APPLICATIONS USING NATIONAL COMPONENTS. PRIOR TO USING OR DISTRIBUTING ANY PRODUCTS THAT INCLUDE NATIONAL COMPONENTS, BUYERS SHOULD PROVIDE ADEQUATE DESIGN, TESTING AND OPERATING SAFEGUARDS.

EXCEPT AS PROVIDED IN NATIONAL'S TERMS AND CONDITIONS OF SALE FOR SUCH PRODUCTS, NATIONAL ASSUMES NO LIABILITY WHATSOEVER, AND NATIONAL DISCLAIMS ANY EXPRESS OR IMPLIED WARRANTY RELATING TO THE SALE AND/OR USE OF NATIONAL PRODUCTS INCLUDING LIABILITY OR WARRANTIES RELATING TO FITNESS FOR A PARTICULAR PURPOSE, MERCHANTABILITY, OR INFRINGEMENT OF ANY PATENT, COPYRIGHT OR OTHER INTELLECTUAL PROPERTY RIGHT.

LIFE SUPPORT POLICY

NATIONAL'S PRODUCTS ARE NOT AUTHORIZED FOR USE AS CRITICAL COMPONENTS IN LIFE SUPPORT DEVICES OR SYSTEMS WITHOUT THE EXPRESS PRIOR WRITTEN APPROVAL OF THE CHIEF EXECUTIVE OFFICER AND GENERAL COUNSEL OF NATIONAL SEMICONDUCTOR CORPORATION. As used herein:

Life support devices or systems are devices which (a) are intended for surgical implant into the body, or (b) support or sustain life and whose failure to perform when properly used in accordance with instructions for use provided in the labeling can be reasonably expected to result in a significant injury to the user. A critical component is any component in a life support device or system whose failure to perform can be reasonably expected to cause the failure of the life support device or system or to affect its safety or effectiveness.

National Semiconductor and the National Semiconductor logo are registered trademarks of National Semiconductor Corporation. All other brand or product names may be trademarks or registered trademarks of their respective holders.

Copyright© 2011 National Semiconductor Corporation

For the most current product information visit us at www.national.com

National Semiconductor
Americas Technical
Support Center
 Email: support@nsc.com
 Tel: 1-800-272-9959

National Semiconductor Europe
Technical Support Center
 Email: europe.support@nsc.com

National Semiconductor Asia
Pacific Technical Support Center
 Email: ap.support@nsc.com

National Semiconductor Japan
Technical Support Center
 Email: jpn.feedback@nsc.com

IMPORTANT NOTICE

Texas Instruments Incorporated and its subsidiaries (TI) reserve the right to make corrections, modifications, enhancements, improvements, and other changes to its products and services at any time and to discontinue any product or service without notice. Customers should obtain the latest relevant information before placing orders and should verify that such information is current and complete. All products are sold subject to TI's terms and conditions of sale supplied at the time of order acknowledgment.

TI warrants performance of its hardware products to the specifications applicable at the time of sale in accordance with TI's standard warranty. Testing and other quality control techniques are used to the extent TI deems necessary to support this warranty. Except where mandated by government requirements, testing of all parameters of each product is not necessarily performed.

TI assumes no liability for applications assistance or customer product design. Customers are responsible for their products and applications using TI components. To minimize the risks associated with customer products and applications, customers should provide adequate design and operating safeguards.

TI does not warrant or represent that any license, either express or implied, is granted under any TI patent right, copyright, mask work right, or other TI intellectual property right relating to any combination, machine, or process in which TI products or services are used. Information published by TI regarding third-party products or services does not constitute a license from TI to use such products or services or a warranty or endorsement thereof. Use of such information may require a license from a third party under the patents or other intellectual property of the third party, or a license from TI under the patents or other intellectual property of TI.

Reproduction of TI information in TI data books or data sheets is permissible only if reproduction is without alteration and is accompanied by all associated warranties, conditions, limitations, and notices. Reproduction of this information with alteration is an unfair and deceptive business practice. TI is not responsible or liable for such altered documentation. Information of third parties may be subject to additional restrictions.

Resale of TI products or services with statements different from or beyond the parameters stated by TI for that product or service voids all express and any implied warranties for the associated TI product or service and is an unfair and deceptive business practice. TI is not responsible or liable for any such statements.

TI products are not authorized for use in safety-critical applications (such as life support) where a failure of the TI product would reasonably be expected to cause severe personal injury or death, unless officers of the parties have executed an agreement specifically governing such use. Buyers represent that they have all necessary expertise in the safety and regulatory ramifications of their applications, and acknowledge and agree that they are solely responsible for all legal, regulatory and safety-related requirements concerning their products and any use of TI products in such safety-critical applications, notwithstanding any applications-related information or support that may be provided by TI. Further, Buyers must fully indemnify TI and its representatives against any damages arising out of the use of TI products in such safety-critical applications.

TI products are neither designed nor intended for use in military/aerospace applications or environments unless the TI products are specifically designated by TI as military-grade or "enhanced plastic." Only products designated by TI as military-grade meet military specifications. Buyers acknowledge and agree that any such use of TI products which TI has not designated as military-grade is solely at the Buyer's risk, and that they are solely responsible for compliance with all legal and regulatory requirements in connection with such use.

TI products are neither designed nor intended for use in automotive applications or environments unless the specific TI products are designated by TI as compliant with ISO/TS 16949 requirements. Buyers acknowledge and agree that, if they use any non-designated products in automotive applications, TI will not be responsible for any failure to meet such requirements.

Following are URLs where you can obtain information on other Texas Instruments products and application solutions:

Products

Audio	www.ti.com/audio
Amplifiers	amplifier.ti.com
Data Converters	dataconverter.ti.com
DLP® Products	www.dlp.com
DSP	dsp.ti.com
Clocks and Timers	www.ti.com/clocks
Interface	interface.ti.com
Logic	logic.ti.com
Power Mgmt	power.ti.com
Microcontrollers	microcontroller.ti.com
RFID	www.ti-rfid.com
OMAP Mobile Processors	www.ti.com/omap
Wireless Connectivity	www.ti.com/wirelessconnectivity

Applications

Communications and Telecom	www.ti.com/communications
Computers and Peripherals	www.ti.com/computers
Consumer Electronics	www.ti.com/consumer-apps
Energy and Lighting	www.ti.com/energy
Industrial	www.ti.com/industrial
Medical	www.ti.com/medical
Security	www.ti.com/security
Space, Avionics and Defense	www.ti.com/space-avionics-defense
Transportation and Automotive	www.ti.com/automotive
Video and Imaging	www.ti.com/video

TI E2E Community Home Page

e2e.ti.com

Mailing Address: Texas Instruments, Post Office Box 655303, Dallas, Texas 75265
Copyright © 2011, Texas Instruments Incorporated