

LM5041A

Cascaded PWM Controller

General Description

The LM5041A PWM controller contains all of the features necessary to implement either current-fed or voltage-fed push-pull or bridge power converters. These "Cascaded" topologies are well suited for multiple output and higher power applications. The LM5041A's four control outputs include: the buck stage controls (HD and LD) and the push-pull control outputs (PUSH and PULL). Push-pull outputs are driven at 50% nominal duty cycle at one half of the switching frequency of the buck stage and can be configured for either a guaranteed overlap time (for current-fed applications) or a guaranteed both-off time (for voltage-fed applications). Push-pull stage MOSFETs can be driven directly from the internal gate drivers while the buck stage requires an external driver such as the LM5102. The LM5041A includes a high-voltage start-up regulator that operates over a wide input range of 15V to 100V. The PWM controller is designed for high-speed capability including an oscillator frequency range up to 1 MHz and total propagation delays of less than 100ns. Additional features include: line Under-Voltage Lockout (UVLO), soft-start, an error amplifier, precision voltage reference, and thermal shutdown.

The two differences between the LM5041 and the LM5041A are: No second level current limit in the 'A' version No softstart (SS) shutdown comparator in the 'A' version .

Features

- Internal Start-up Bias Regulator
- Programmable Line Under-Voltage Lockout (UVLO) with Adjustable Hysteresis
- Current Mode Control
- Internal Error Amplifier with Reference
- Cycle-by-cycle Over-Current Protection
- Leading Edge Blanking
- Programmable Push-Pull Overlap or Dead Time
- Internal 1.5A Push-Pull Gate Drivers
- Programmable Soft-start
- Programmable Oscillator with Sync Capability
- Precision Reference
- Thermal Shutdown

Applications

- Telecommunication Power Converters
- Industrial Power Converters
- Multi-Output Power Converters
- +42V Automotive Systems

Packages

- TSSOP-16
- LLP-16 (5x5 mm) Thermally Enhanced

Typical Application Circuit

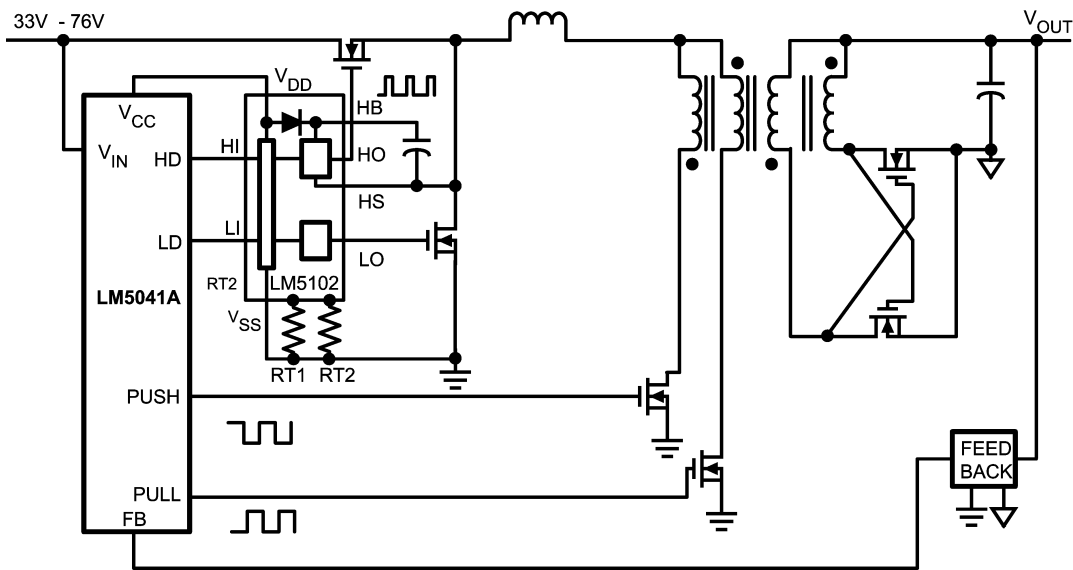

Simplified Cascaded Push-Pull Power Converter

20137801

Connection Diagram

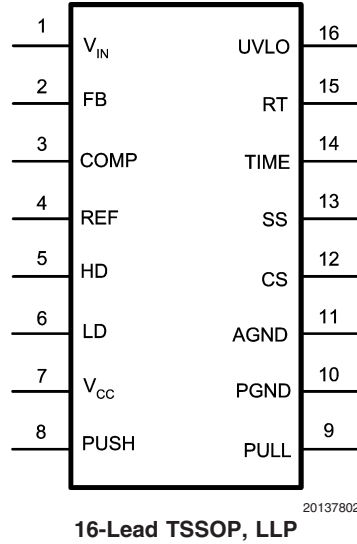

Ordering Information

Order Number	Package Type	NSC Package Drawing	Supplied As
LM5041AMTC	TSSOP-16	MTC-16	92 Units per anti-static tube
LM5041AMTCX	TSSOP-16	MTC-16	2500 Units on Tape and Reel
LM5041ASD	LLP-16	SDA-16A	1000 Units on Tape and Reel
LM5041ASDX	LLP-16	SDA-16A	4500 Units on Tape and Reel

Pin Description

PIN	NAME	DESCRIPTION	APPLICATION INFORMATION
1	V _{IN}	Source Input Voltage	Input to start-up regulator. Input range 15V to 100V.
2	FB	Feedback Signal	Inverting input for the internal error amplifier. The non-inverting input is connected to a 0.75V reference.
3	COMP	Output of the Internal Error Amplifier	There is an internal 5kΩ resistor pull-up on this pin. The error amplifier provides an active sink.
4	REF	Precision 5 volt reference output	Maximum output current: 10mA. Locally decouple with a 0.1μF capacitor. Reference stays low until the line UV and the V _{CC} UV are satisfied.
5	HD	Main Buck PWM control output	Buck switch PWM control output. The maximum duty cycle clamp for this output corresponds to an off time of typically 240ns per cycle. The LM5101 or LM5102 Buck stage gate driver can be used to level shift and drive the Buck switch.
6	LD	Sync Switch control output	Sync Switch control output. Inversion of HD output. The LM5101 or LM5102 lower drive can be used to drive the synchronous rectifier switch.
7	V _{CC}	Output from the internal high voltage start-up regulator. Regulated to 9 volts.	If an auxiliary winding raises the voltage on this pin above the regulation setpoint, the internal start-up regulator will shutdown, reducing the IC power dissipation.
8	PUSH	Output of the push-pull drivers	Output of the push-pull gate driver. Output capability of 1.5A peak .

Pin Description (Continued)

PIN	NAME	DESCRIPTION	APPLICATION INFORMATION
9	PULL	Output of the push-pull drivers	Output of the push-pull gate driver. Output capability of 1.5A peak.
10	PGND	Power ground	Connect directly to analog ground.
11	AGND	Analog ground	Connect directly to power ground.
12	CS	Current sense input	Current sense input to the PWM comparator (CM control). There is a 50ns leading edge blanking on this pin. Using separate dedicated comparator, if CS exceeds 0.5V the outputs will go into cycle by cycle current limit.
13	SS	Soft-start control	An external capacitor and an internal 10uA current source, set the soft-start ramp.
14	TIME	Push-Pull overlap and dead time control	An external resistor (R_{SET}) sets the overlap time or dead time for the push-pull outputs. A resistor connected between TIME and GND produces overlap. A resistor connected between TIME and REF produces dead time.
15	RT / SYNC	Oscillator timing resistor pin and sync	An external resistor sets the oscillator frequency. This pin will also accept an external oscillator.
16	UVLO	Line Under-Voltage Shutdown	An external divider from the power converter source sets the shutdown levels. Threshold of operation equals 2.5V. Hysteresis is set by a switched internal current source (20 μ A).
LLP DAP	SUB	Die substrate	The exposed die attach pad on the LLP package should be connected to a PCB thermal pad at ground potential. For additional information on using National Semiconductor's No Pull Back LLP package, please refer to LLP Application Note AN-1187.

Block Diagram

Simplified Block Diagram

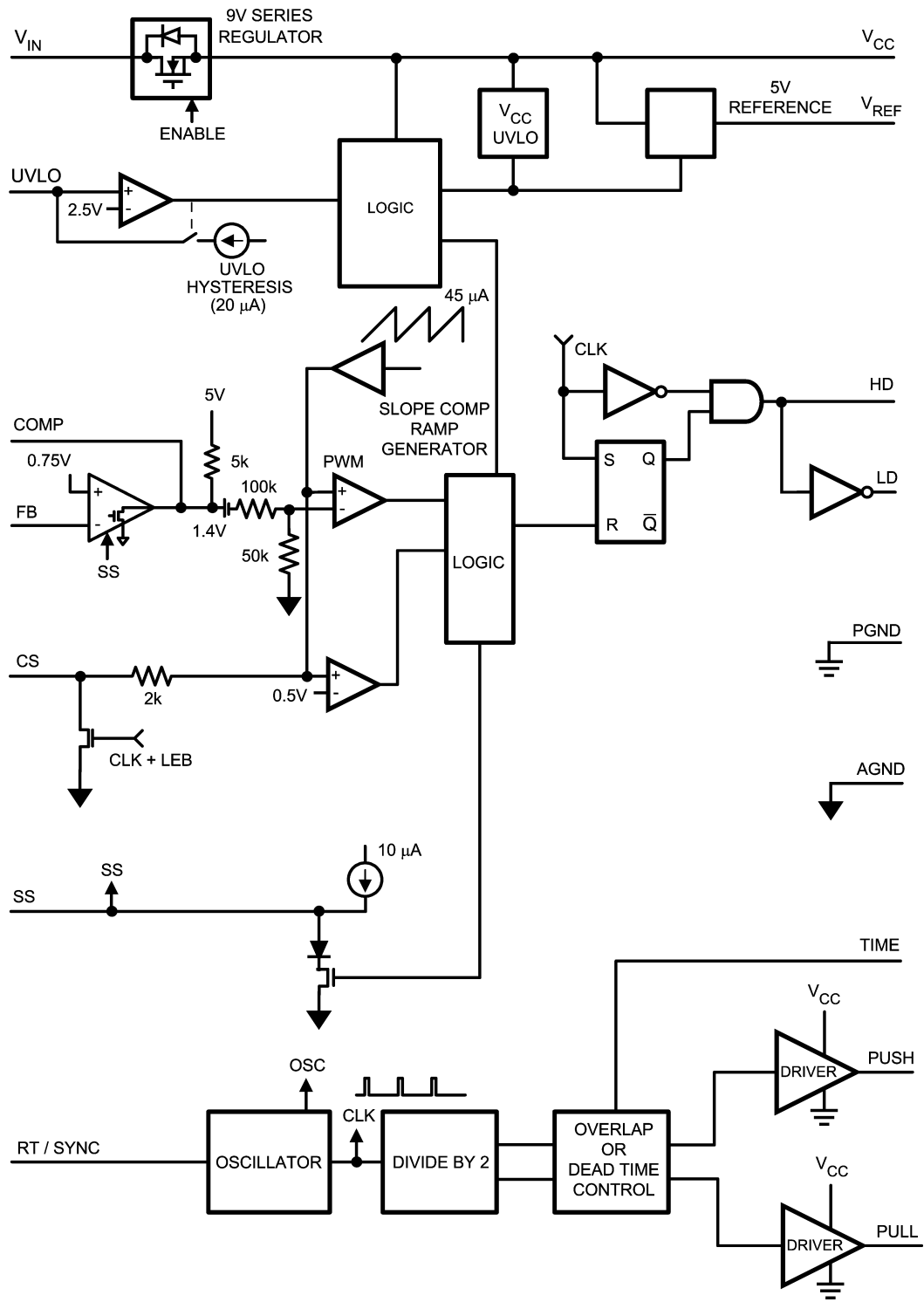

20137803

Absolute Maximum Ratings (Note 1)

If Military/Aerospace specified devices are required, please contact the National Semiconductor Sales Office/Distributors for availability and specifications.

V_{IN} to GND	100V
V_{CC} to GND	16V
All Other Inputs to GND	-0.3 to 7V
Junction Temperature	150°C
Storage Temperature Range	-65°C to +150°C

ESD Rating	2 kV
Lead temperature (Note 2)	
Wave	4 seconds 260°C
Infrared	10 seconds 240°C
Vapor Phase	75 seconds 219°C

Operating Ratings (Note 1)

V_{IN}	15 to 90V
Junction Temperature	-40°C to +125°C

Electrical Characteristics

Specifications with standard typeface are for $T_J = 25^\circ\text{C}$, and those with **boldface** type apply over full **Operating Junction Temperature range**. $V_{IN} = 48\text{V}$, $V_{CC} = 10\text{V}$, $R_T = 26.7\text{k}\Omega$, $R_{SET} = 20\text{k}\Omega$ unless otherwise stated (Note 3)

Symbol	Parameter	Conditions	Min	Typ	Max	Units
Startup Regulator						
V_{CC} Reg	V_{CC} Regulation	open circuit	8.7	9	9.3	V
	V_{CC} Current Limit	(Note 4)	15	25		mA
$I-V_{IN}$	Startup Regulator Leakage (external V_{CC} Supply)	$V_{IN} = 100\text{V}$		145	500	μA
	Shutdown Current (lin)	UVLO = 0V, V_{CC} = open		350	450	μA
V_{CC} Supply						
	V_{CC} Under-voltage Lockout Voltage (positive going V_{CC})		V_{CC} Reg - 400mV	V_{CC} Reg - 275mV		V
	V_{CC} Under-voltage Hysteresis		1.7	2.1	2.6	V
	Supply Current (I_{CC})	$C_L = 0$		3	4	mA
Error Amplifier						
GBW	Gain Bandwidth			3		MHz
	DC Gain			80		dB
	Input Voltage	$V_{FB} = \text{COMP}$	0.735	0.75	0.765	V
	COMP Sink Capability	$V_{FB} = 1.5\text{V}$, COMP = 1V	4	8		mA
Reference Supply						
V_{REF}	Ref Voltage	$I_{REF} = 0\text{ mA}$	4.85	5	5.15	V
	Ref Voltage Regulation	$I_{REF} = 0$ to 10mA		25	50	mV
	Ref Current Limit		15	20		mA
Current Limit						
	ILIM Delay to Output	CS Step from 0 to 0.6V Time to Onset of OUT Transition (90%) $C_L = 0$		40		ns
	Cycle by Cycle Threshold Voltage		0.45	0.5	0.55	V
	Leading Edge Blanking Time			50		ns
	CS Sink Current (clocked)	CS = 0.3V	2	5		mA

Electrical Characteristics (Continued)

Specifications with standard typeface are for $T_J = 25^\circ\text{C}$, and those with **boldface** type apply over full **Operating Junction Temperature range**. $V_{IN} = 48\text{V}$, $V_{CC} = 10\text{V}$, $R_T = 26.7\text{k}\Omega$, $R_{SET} = 20\text{k}\Omega$ unless otherwise stated (Note 3)

Symbol	Parameter	Conditions	Min	Typ	Max	Units
Soft-Start						
	Soft-start Current Source		7	10	13	μA
	Soft-start to COMP Offset		0.35	0.55	0.75	V
Oscillator						
	Frequency1 (RT = 26.7k Ω)	$T_J = 25^\circ\text{C}$	180 175	200	220 225	kHz
	Frequency2 (RT = 7.87k Ω)		515	600	685	kHz
	Sync threshold			3	3.5	V
PWM Comparator						
	Delay to Output	COMP set to 2V CS stepped 0 to 0.4V, Time to onset of OUT transition low		25		ns
	Max Duty Cycle	TS = Oscillator Period		(Ts-240ns)/Ts)		%
	Min Duty Cycle	COMP = 0V			0	%
	COMP to PWM Comparator Gain			0.32		
	COMP Open Circuit Voltage	FB = 0V	4.1	4.8	5.5	V
	COMP Short Circuit Current	FB = 0V, COMP = 0V	0.6	1	1.4	mA
Slope Compensation						
	Slope Comp Amplitude	Delta increase at PWM Comparator to CS		110		mV
UVLO Shutdown						
	Under-voltage Shutdown		2.44	2.5	2.56	V
	Under-voltage Shutdown Hysteresis Current Source		16	20	24	μA
Buck Stage Outputs						
	Output High level			5 (V_{REF})		V
	Output High Saturation	$I_{OUT} = 10\text{mA}$ REF = V_{OUT}		0.5	1	V
	Output Low Saturation	$I_{OUT} = -10\text{mA}$		0.5	1	V
	Rise Time	$C_L = 100\text{pF}$		10		ns
	Fall Time	$C_L = 100\text{pF}$		10		ns
Push-Pull Outputs						
	Overlap Time	$R_{SET} = 20\text{k}\Omega$ Connected to GND, 50% to 50% Transitions	60	90	120	ns
	Dead Time	$R_{SET} = 20\text{k}\Omega$ Connected to REF, 50% to 50% Transitions	65	95	125	ns
	Output High Saturation	$I_{OUT} = 50\text{mA}$ $V_{CC} - V_{OUT}$		0.25	0.5	V

Electrical Characteristics (Continued)

Specifications with standard typeface are for $T_J = 25^\circ\text{C}$, and those with **boldface** type apply over full **Operating Junction Temperature range**. $V_{IN} = 48\text{V}$, $V_{CC} = 10\text{V}$, $R_T = 26.7\text{k}\Omega$, $R_{SET} = 20\text{k}\Omega$ unless otherwise stated (Note 3)

Symbol	Parameter	Conditions	Min	Typ	Max	Units
	Output Low Saturation	$I_{OUT} = 100\text{mA}$		0.5	1	V
	Rise Time	$C_L = 1\text{nF}$		20		ns
	Fall Time	$C_L = 1\text{nF}$		20		ns

Thermal Shutdown

T_{SD}	Thermal Shutdown Temp.			165		$^\circ\text{C}$
	Thermal Shutdown Hysteresis			25		$^\circ\text{C}$

Thermal Resistance

θ_{JA}	Junction to Ambient	MTC Package		125		$^\circ\text{C/W}$
		SDA Package		32		$^\circ\text{C/W}$

Note 1: Absolute Maximum Ratings are limits beyond which damage to the device may occur. Operating Ratings are conditions under which operation of the device is intended to be functional. For guaranteed specifications and test conditions, see the Electrical Characteristics.

Note 2: For detailed information on soldering plastic TSSOP and LLP packages, refer to the Packaging Data Book available from National Semiconductor Corporation.

Note 3: All limits are guaranteed. All electrical characteristics having room temperature limits are tested during production with $T_A = T_J = 25^\circ\text{C}$. All hot and cold limits are guaranteed by correlating the electrical characteristics to process and temperature variations and applying statistical process control.

Note 4: Device thermal limitations may limit usable range.

Typical Performance Characteristics

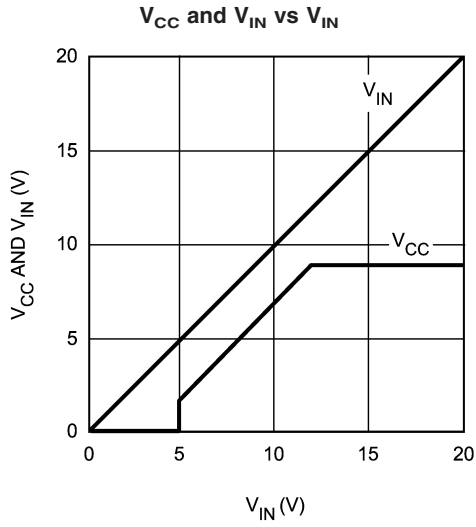

20137808

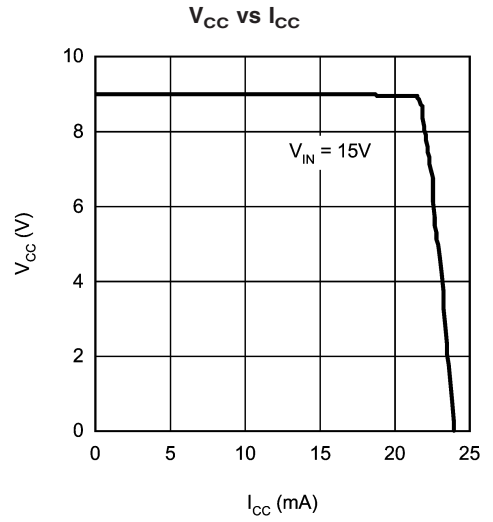

20137809

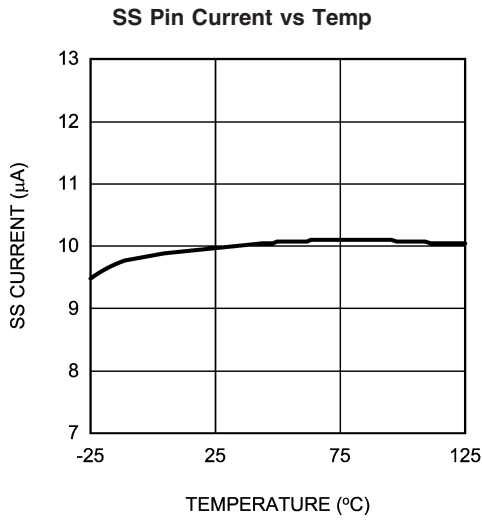

20137815

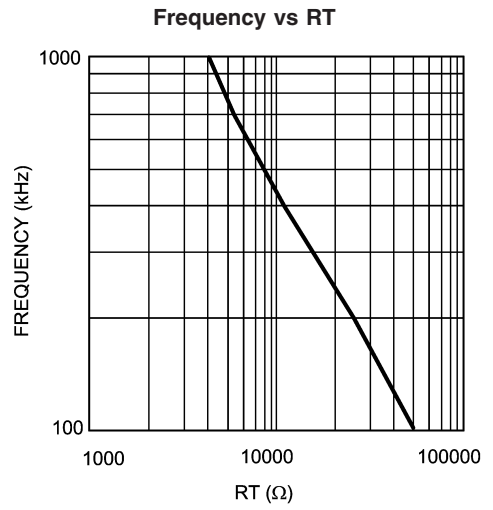

20137810

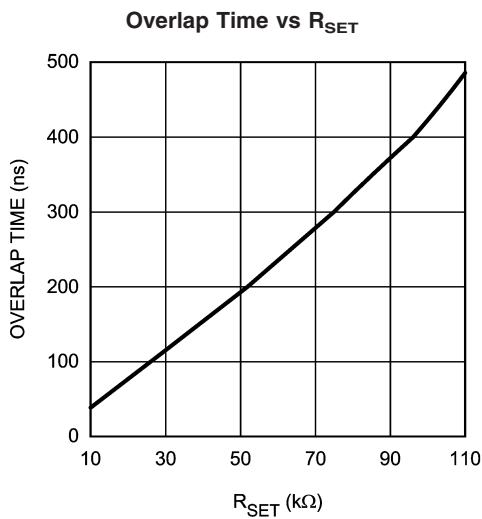

20137811

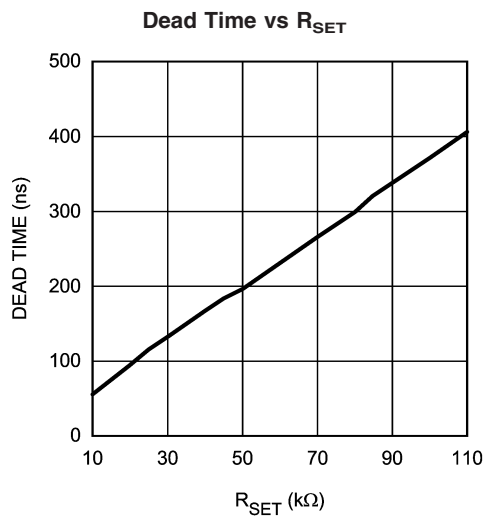

20137812

Typical Performance Characteristics (Continued)

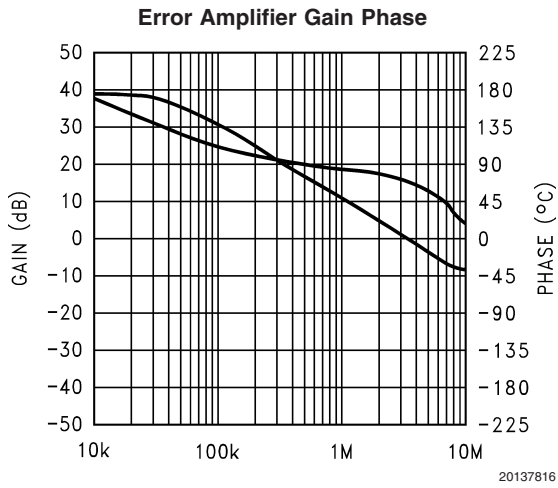
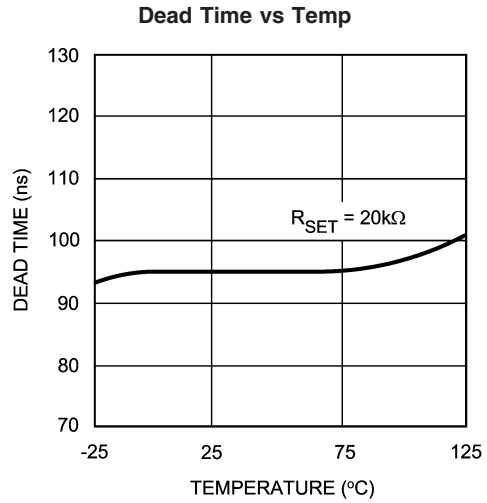
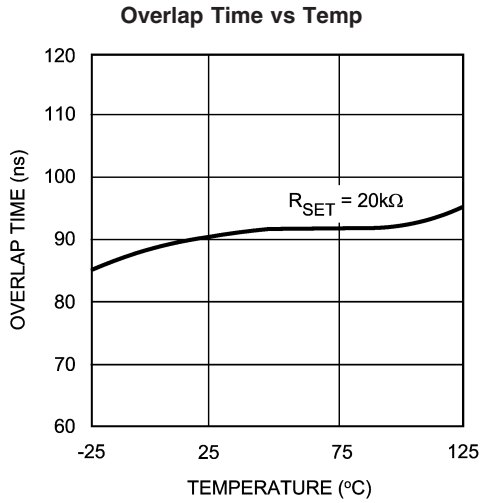

Detailed Operating Description

The LM5041A PWM controller contains all of the features necessary to implement either current-fed or voltage-fed push-pull or bridge power converters. These “Cascaded” topologies are well suited for multiple output and higher power applications. The LM5041A's four control outputs include: the buck stage controls (HD and LD) and the push-pull control outputs (PUSH and PULL). Push-pull outputs are driven at 50% nominal duty cycle at one half of the switching frequency of the buck stage and can be configured for either a guaranteed overlap time (for current-fed applications) or a guaranteed both-off time (for voltage-fed applications). Push-pull stage MOSFETs can be driven directly from the internal gate drivers while the buck stage requires an external driver such as the LM5102. The LM5041A includes a high-voltage start-up regulator that operates over a wide input range of 15V to 100V. The PWM controller is designed for high-speed capability including an oscillator frequency range up to 1 MHz and total propagation delays of less than 100ns. Additional features include: line Under-Voltage Lockout (UVLO), soft-start, an error amplifier, precision voltage reference, and thermal shutdown.

High Voltage Start-Up Regulator

The LM5041A contains an internal high-voltage start-up regulator, thus the input pin (V_{in}) can be connected directly to the line voltage. The regulator output is internally current limited to 15mA. When power is applied, the regulator is enabled and sources current into an external capacitor connected to the V_{cc} pin. The recommended capacitance range for the V_{cc} regulator is 0.1 μ F to 100 μ F. When the voltage on the V_{cc} pin reaches the regulation point of 9V and the internal voltage reference (REF) reaches its regulation point of 5V, the controller outputs are enabled. The Buck stage outputs will remain enabled until V_{cc} falls below 7V or the line Under-Voltage Lockout detector indicates that V_{in} is out of range. The push-pull outputs continue switching until the REF pin voltage falls below approximately 3V. In typical applications, an auxiliary transformer winding is connected through a diode to the V_{cc} pin. This winding must raise the V_{cc} voltage above 9.3V to shut off the internal start-up regulator. Powering V_{CC} from an auxiliary winding improves efficiency while reducing the controller's power dissipation. The recommended capacitance range for the V_{ref} regulator output is 0.1 μ F to 10 μ F.

The external V_{CC} capacitor must be sized such that the capacitor maintains a V_{CC} voltage greater than 7V during the initial start-up. During a fault mode when the converter auxiliary winding is inactive, external current draw on the V_{CC} line should be limited so the power dissipated in the start-up regulator does not exceed the maximum power dissipation of the controller.

An external start-up or other bias rail can be used instead of the internal start-up regulator by connecting the V_{CC} and the V_{IN} pins together and feeding the external bias voltage into the two pins.

Line Under-Voltage Detector

The LM5041A contains a line Under-Voltage Lockout (UVLO) circuit. An external set-point resistor divider from V_{IN} to ground sets the operational range of the converter. The divider must be designed such that the voltage at the UVLO pin will be greater than 2.5V when V_{IN} is in the desired operating range. If the Under-Voltage threshold is not met, all functions of the controller are disabled and the controller will enter a low-power state with input current $<300\mu$ A. ULVO hysteresis is accomplished with an internal 20 μ A current source that is switched on or off into the impedance of the set-point divider. When the UVLO threshold is exceeded, the current source is activated to instantly raise the voltage at the UVLO pin. When the UVLO pin falls below the 2.5V threshold, the current source is turned off causing the voltage at the UVLO pin to fall. The UVLO pin can also be used to implement a remote enable / disable function. By shorting the UVLO pin to ground, the converter can be disabled.

Buck Stage Control Outputs

The LM5041A Buck switch maximum duty cycle clamp ensures that there will be sufficient off time each cycle to recharge the bootstrap capacitor used in the high side gate driver. The Buck switch is guaranteed to be off, and the sync switch on, for at least 250ns per switching cycle. The Buck stage control outputs (LD and HD) are CMOS buffers with logic levels of 0 to 5V.

During any fault state or Under-Voltage off state, the buck stage control outputs will default to HD low and LD high.

Push-Pull Outputs

The push pull outputs operate continuously at a nominal 50% duty cycle. A distinguishing feature of the LM5041A is the ability to accurately configure either dead time (both-off) or overlap time (both-on) on the complementary push-pull outputs. The overlap/dead time magnitude is controlled by a resistor connected to the TIME pin on the controller. The TIME pin holds one end of the resistor at 2.5V and the other end of the resistor should be connected to either REF for dead time control setting or to GND for overlap control. The polarity of the current in the TIME is detected by the LM5041A. The magnitude of the overlap/dead time can be calculated as follows:

$$\text{Overlap Time (ns)} = (3.66 \times R_{SET}) + 7$$

Overlap Time in ns, R_{SET} connected to GND, R_{SET} in k Ω

$$\text{Dead Time (ns)} = (3.69 \times R_{SET}) + 21$$

Dead Time in ns, R_{SET} connected to REF, R_{SET} in k Ω

Recommended R_{SET} programming range: 10k Ω to 100k Ω

Current-fed designs require a period of overlap to insure there is a continuous path for the buck inductor current. Voltage-fed designs require a period of dead time to insure there is no time when the push-pull transformer acts as a shorted turn to the low impedance sourcing node. The push-pull outputs alternate continuously under all conditions provided REF the voltage is greater than 3V.

Push-Pull Outputs (Continued)

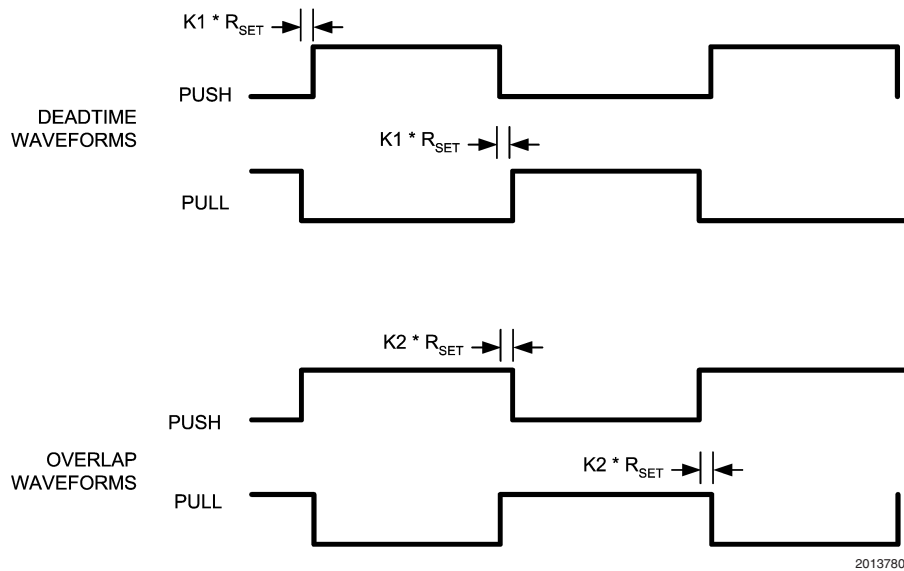

PWM Comparator

The PWM comparator compares the slope compensated current ramp signal to the loop error voltage from the internal error amplifier (COMP pin). This comparator is optimized for speed in order to achieve minimum controllable duty cycles. The comparator polarity is such that 0V on the COMP pin will produce zero duty cycle in the buck stage.

Error Amplifier

An internal high gain wide-bandwidth error amplifier is provided within the LM5041A. The amplifier's non-inverting input is tied to a 0.75V reference. The inverting input is connected to the FB pin. In non-isolated applications the power converter output is connected to the FB pin via the voltage setting resistors. Loop compensation components are connected between the COMP and FB pins. For most isolated applications the error amplifier function is implemented on the secondary side of the converter and the internal error amp is not used. The internal error amplifier is configured as an open drain output and can be disabled by connecting the FB pin to ground. An internal 5kΩ pull-up resistor between the 5V reference and COMP can be used as the pull-up for an opto-coupler in isolated applications.

Current Limit/Current Sense

The LM5041A provides cycle-by-cycle over-current protection. If the voltage at the CS comparator (CS pin voltage plus slope comp voltage) exceeds 0.5V the present buck stage duty cycle is terminated (cycle by cycle current limit). A small RC filter located near the controller is recommended to filter current sense signals at the CS pin. An internal MOSFET discharges the external CS pin for an additional 50ns at the beginning of each cycle to reduce the leading edge spike that occurs when the buck stage MOSFET is turned on.

The LM5041A current sense and PWM comparators are very fast, and may respond to short duration noise pulses. Layout considerations are critical for the current sense filter and sense resistor. The capacitor associated with the CS

filter must be placed close to the device and connected directly to the pins of the controller (CS and GND). If a current sense transformer is used, both leads of the transformer secondary should be routed to the sense resistor, which should also be located close to the IC. A resistor may be used for current sensing instead of a transformer, located in the push-pull transistor sources, but a low inductance type of resistor is required. When designing with a sense resistor, all of the noise sensitive low power grounds should be connected together around the IC and a single connection should be made to the high current power ground (sense resistor ground point).

Oscillator and Sync Capability

The LM5041A oscillator is set by a single external resistor connected between the RT pin and GND. To set a desired oscillator frequency (F), the necessary RT resistor can be calculated from:

$$RT = \frac{(1/F) - 235 \times 10^{-9}}{182 \times 10^{-12}} \Omega$$

The buck stage will switch at the oscillator frequency and each push-pull output will switch at half the oscillator frequency in a push-pull configuration. The LM5041A can also be synchronized to an external clock. The external clock must have a higher frequency than the free running frequency set by the RT resistor. The clock signal should be capacitively coupled into the RT pin with a 100pF capacitor. A peak voltage level greater than 3V is required for detection of the sync pulse. The sync pulse width should be set in the 15 to 150ns range by the external components. The RT resistor is always required, whether the oscillator is free running or externally synchronized. The voltage at the RT pin is internally regulated to 2V. The RT resistor should be located very close to the device and connected directly to the pins of the IC (RT and GND).

Slope Compensation

The PWM comparator compares the current sense signal to the voltage at the COMP pin. The output stage of the internal error amplifier generally drives the COMP pin. At duty cycles greater than 50 percent, current mode control circuits are subject to sub-harmonic oscillation. By adding an additional fixed ramp signal (slope compensation) to the current sense ramp, oscillations can be avoided. The LM5041A integrates this slope compensation by buffering the internal oscillator ramp and summing a current ramp generated by the oscillator internally with the current sense signal. Additional slope compensation may be provided by increasing the source impedance of the current sense signal.

Soft-start and Shutdown

The soft-start feature allows the power converter to gradually reach the initial steady state operating point, thereby reducing start-up stresses and surges. At power on, a 10 μ A current is sourced out of the soft-start pin (SS) to charge an external capacitor. The capacitor voltage will ramp up slowly and will limit the maximum duty cycle of the buck stage. In the event of a fault as indicated by V_{CC} Under-voltage, line Under-voltage the output drivers are disabled and the soft-start capacitor is discharged to 0.7V. When the fault condition is no longer present, a soft-start sequence will begin again and buck stage duty cycle will gradually increase as the soft-start capacitor is charged.

Thermal Protection

Internal Thermal Shutdown circuitry is provided to protect the integrated circuit in the event that the maximum junction temperature is exceeded. When activated, typically at 165 degrees Celsius, the controller is forced into a low-power standby state, disabling the output drivers and the bias regulator. This feature is provided to prevent catastrophic failures from accidental device overheating.

Typical Application

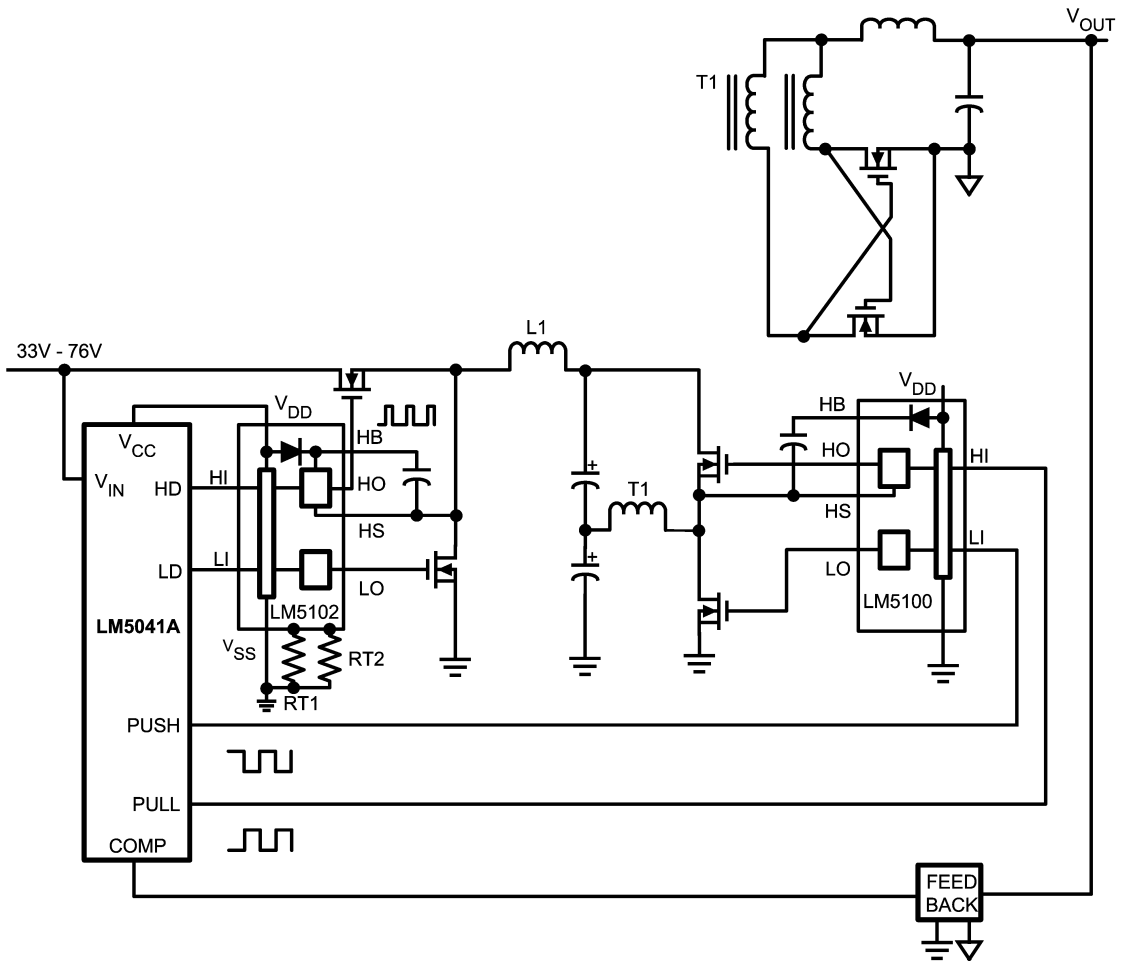

20137806

FIGURE 1. Simplified Cascaded Half-Bridge

Application Circuit: Input 35-80V, Output 2.5V, 50A

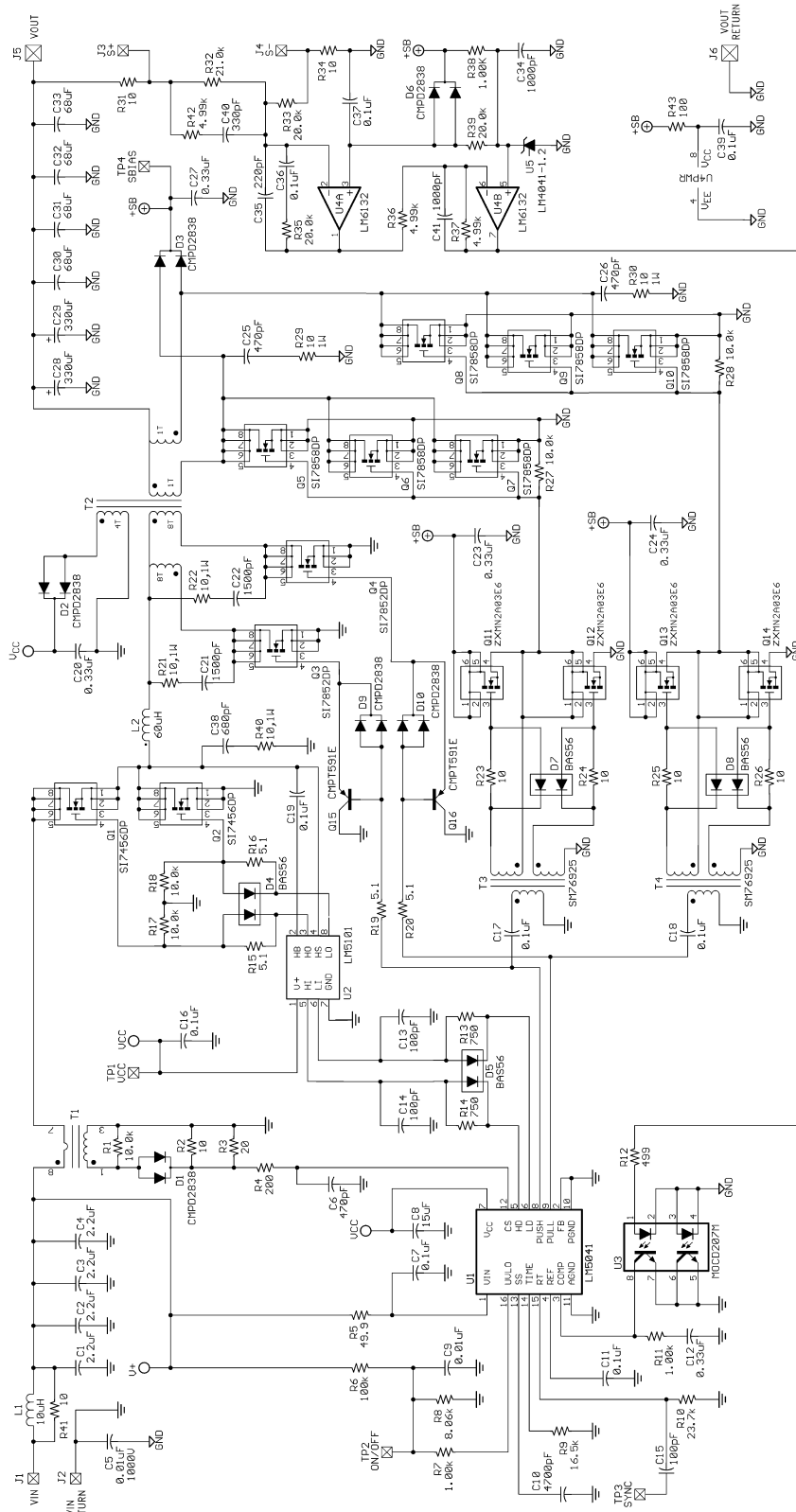

20137607

Physical Dimensions inches (millimeters)

unless otherwise noted

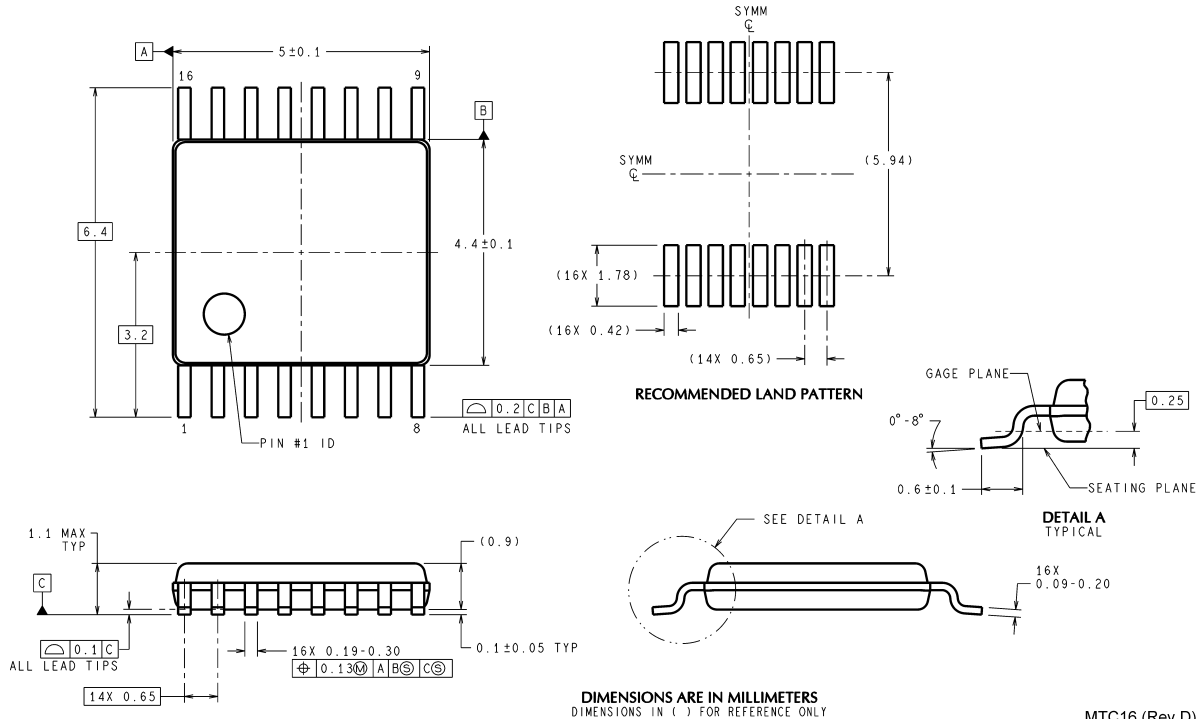

DIMENSIONS ARE IN MILLIMETERS
DIMENSIONS IN () FOR REFERENCE ONLY

MTC16 (Rev D)

Molded TSSOP-16
NS Package Number MTC16

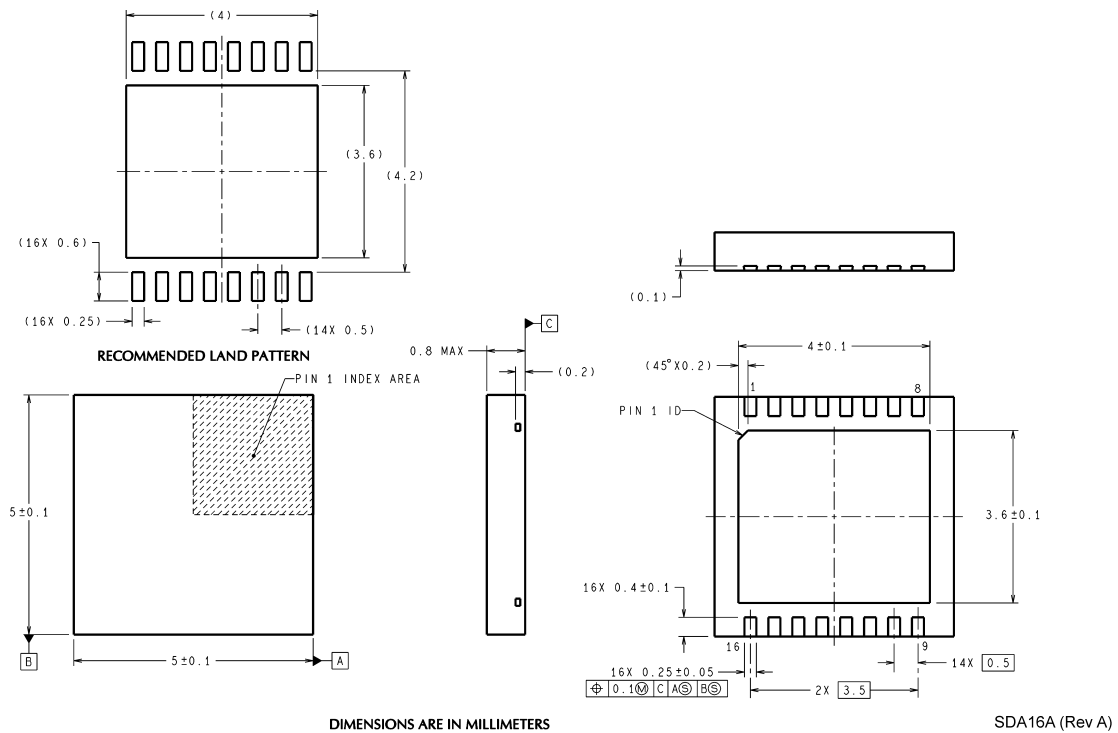

DIMENSIONS ARE IN MILLIMETERS

SDA16A (Rev A)

16-Lead LLP Surface Mount Package
NS Package Number SDA16A

Notes

National does not assume any responsibility for use of any circuitry described, no circuit patent licenses are implied and National reserves the right at any time without notice to change said circuitry and specifications.

For the most current product information visit us at www.national.com.

LIFE SUPPORT POLICY

NATIONAL'S PRODUCTS ARE NOT AUTHORIZED FOR USE AS CRITICAL COMPONENTS IN LIFE SUPPORT DEVICES OR SYSTEMS WITHOUT THE EXPRESS WRITTEN APPROVAL OF THE PRESIDENT AND GENERAL COUNSEL OF NATIONAL SEMICONDUCTOR CORPORATION. As used herein:

1. Life support devices or systems are devices or systems which, (a) are intended for surgical implant into the body, or (b) support or sustain life, and whose failure to perform when properly used in accordance with instructions for use provided in the labeling, can be reasonably expected to result in a significant injury to the user.
2. A critical component is any component of a life support device or system whose failure to perform can be reasonably expected to cause the failure of the life support device or system, or to affect its safety or effectiveness.

BANNED SUBSTANCE COMPLIANCE

National Semiconductor manufactures products and uses packing materials that meet the provisions of the Customer Products Stewardship Specification (CSP-9-111C2) and the Banned Substances and Materials of Interest Specification (CSP-9-111S2) and contain no "Banned Substances" as defined in CSP-9-111S2.

Leadfree products are RoHS compliant.



National Semiconductor
Americas Customer
Support Center
Email: new.feedback@nsc.com
Tel: 1-800-272-9959

www.national.com

National Semiconductor
Europe Customer Support Center
Fax: +49 (0) 180-530 85 86
Email: europe.support@nsc.com
Deutsch Tel: +49 (0) 69 9508 6208
English Tel: +44 (0) 870 24 0 2171
Français Tel: +33 (0) 1 41 91 8790

National Semiconductor
Asia Pacific Customer
Support Center
Email: ap.support@nsc.com

National Semiconductor
Japan Customer Support Center
Fax: 81-3-5639-7507
Email: jpn.feedback@nsc.com
Tel: 81-3-5639-7560