



Line Drivers/Receivers

LM55121/LM75121 dual line drivers

general description

The LM55121/LM75121 are monolithic dual line drivers designed to drive long lengths of coaxial cable, strip line, or twisted pair transmission lines having impedances from 50 to 500 ohms. Both are compatible with standard TTL logic and supply voltage levels.

The LM55121/LM75121 will drive terminated low impedance lines due to the low-impedance emitter-follower outputs. In addition the outputs are uncommitted allowing two or more drivers to drive the same line.

Output short-circuit protection is incorporated to turn off the output when the output voltage drops below approximately 1.5V.

features

- Designed for digital data transmission over 50 to 500 ohms coaxial cable, strip line, or twisted pair transmission lines
- TTL compatible
- Open emitter-follower output structure for party-line operation
- Short-circuit protection
- AND-OR logic configuration
- High speed (max propagation delay time 20 ns)
- Plug-in replacement for the SN55121 and the 8T13

connection diagram

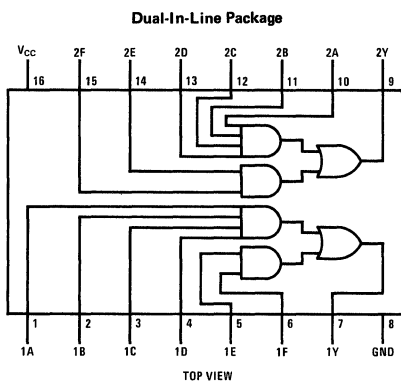

Order Number LM55121J or LM75121J
See Package 17

Order Number LM75121N
See Package 23

typical performance characteristics

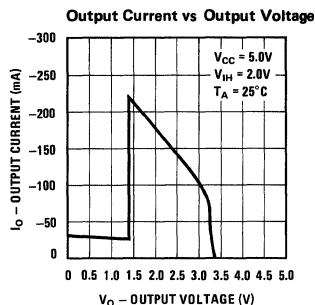

truth table

INPUTS						OUTPUT
A	B	C	D	E	F	Y
H	H	H	H	X	X	H
X	X	X	X	H	H	H
All Other Input Combinations						L

H = high level, L = low level, X = irrelevant

ac test circuit and switching time waveforms

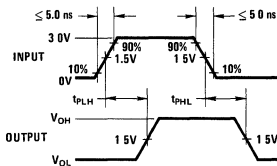
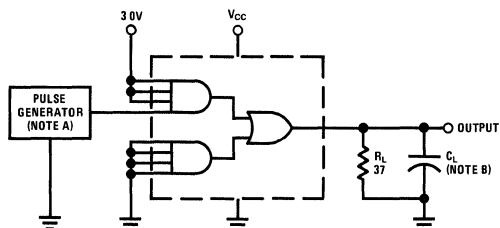

Note A: The pulse generators have the following characteristics
 $Z_{OUT} \approx 50\Omega$, $t_w = 200$ ns, duty cycle = 50%, $t_r = t_f = 5.0$ ns
 Note B: C_L includes probe and jig capacitance

absolute maximum ratings

(Notes 1 and 2)

Supply Voltage, V_{CC}	6.0V
Input Voltage	6.0V
Output Voltage	6.0V
Output Current	-75 mA
Continuous Total Dissipation at (or below)	
25°C Free-Air Temperature (Note 5)	800 mW
Lead Temperature (Soldering, 10 seconds)	300°C

operating conditions

	MIN	MAX	UNITS
Supply Voltage, V_{CC}	4.75	5.25	V
Temperature, T_A			
LM55121	-55	+125	°C
LM75121	0	+75	°C

electrical characteristics (Note 3) $V_{CC} = 4.75V$ to $5.25V$ (unless otherwise noted)

PARAMETER	CONDITIONS	MIN	TYP	MAX	UNITS
High Level Input Voltage (V_{IH})		2.0			V
Low Level Input Voltage (V_{IL})				0.8	V
Input Clamp Voltage (V_I)	$V_{CC} = 5.0V, I_I = -12$ mA			-1.5	V
Input Breakdown Voltage (V_{BR1})	$V_{CC} = 5.0V, I_I = 10$ mA	5.5			V
High Level Output Voltage (V_{OH})	$V_{IH} = 2.0V, I_{OH} = -75$ mA (Note 4)	2.4			V
High Level Output Current (I_{OH})	$V_{CC} = 5.0V, V_{IH} = 4.75V, V_{OH} = 2.0V, T_A = 25^\circ C$ (Note 4)	-100		-250	mA
Low Level Output Current (I_{OL})	$V_{IL} = 0.8V, V_{OL} = 0.4V$ (Note 4)			-800	μA
Off State Output Current ($I_{O(OFF)}$)	$V_{CC} = 0V, V_O = 3.0V$			500	μA
High Level Input Current (I_{IH})	$V_I = 4.5V$			40	μA
Low Level Input Current (I_{IL})	$V_I = 0.4V$	-0.1		-1.6	mA
Short Circuit Output Current (I_{OS})	$V_{CC} = 5.0V, T_A = 25^\circ C$			-30	mA
Supply Current, Outputs High (I_{CCH})	$V_{CC} = 5.25V$, All Inputs at 2.0V, Outputs Open			28	mA
Supply Current, Outputs Low (I_{CCL})	$V_{CC} = 5.25V$, All Inputs at 0.8V, Outputs Open			60	mA

4

switching characteristics $V_{CC} = 5.0V, T_A = 25^\circ C$

PARAMETER	CONDITIONS	MIN	TYP	MAX	UNITS
Propagation Delay Time, Low to High Level Output (t_{PLH})	$R_L = 37\Omega, C_L = 15$ pF (See AC Test Circuit and Switching Time Waveforms)		11	20	ns
Propagation Delay Time, High to Low Level Output (t_{PHL})			8.0	20	ns
Propagation Delay Time, Low to High Level Output (t_{PLH})	$R_L = 37\Omega, C_L = 1000$ pF (See AC Test Circuit and Switching Time Waveforms)		22	50	ns
Propagation Delay Time, High to Low Level Output (t_{PHL})			20	50	ns

Note 1: "Absolute Maximum Ratings" are those values beyond which the safety of the device cannot be guaranteed. Except for "Operating Temperature Range" they are not meant to imply that the devices should be operated at these limits. The table of "Electrical Characteristics" provides conditions for actual device operation.

Note 2: All currents into device pins are shown as positive, currents out of device pins shown as negative, all voltage values are referenced with respect to network ground terminal, unless otherwise noted. All values shown as max or min on absolute value basis.

Note 3: Min/max limits apply across the guaranteed operating temperature range of $-55^\circ C$ to $+125^\circ C$ for LM55121 and $0^\circ C$ to $+75^\circ C$ for LM75121, unless otherwise specified. Typical values are for $V_{CC} = 5.0V, T_A = 25^\circ C$. Positive current is defined as current into the referenced pin.

Note 4: The output voltage and current limits are guaranteed for any appropriate combination of high and low inputs specified by the truth table for the desired output.

Note 5: For operating at elevated temperatures, the cavity DIP package (J) must be derated based on a thermal resistance of $+85^\circ C/W$, junction to ambient. The molded DIP package (N) must be derated based on a thermal resistance of $+150^\circ C/W$, junction to ambient.