



深圳市拓普微科技开发有限公司

SHENZHEN TOPWAY TECHNOLOGY CO., LTD.

LM6067BFW

LCD Module User Manual

Prepared by: K.C. Date: 2010-11-27	Checked by: Date:	Approved by: Date:
---	----------------------------------	-----------------------------------

Rev.	Descriptions	Release Date
0.1	New release	2008-11-28
0.2	Revise Terminal Functions	2010-11-05
0.3	Typing Correction in Terminal Functions Descriptions Extend VIH, VIL value in DC Characteristics	2010-11-27

Table of Content

1. Basic Specifications	3
1.1 Display Specifications	3
1.2 Mechanical Specifications	3
1.3 Block Diagram	3
1.4 Terminal Functions	4
2. Absolute Maximum Ratings	5
3. Electrical Characteristics	5
3.1 DC Characteristics	5
3.2 LED Backlight Circuit Characteristics	5
3.3 AC Characteristics	6
4. Function Specifications.....	6
4.1 Adjusting the Display Contrast	7
4.2 Resetting the LCD module	7
4.3 Display Pixel Map.....	8
4.4 Control Data and Command	9
4.5 Register Table Summary	9
4.6 Initialization Setting Example	11
5. Design and Handling Precaution	11

1. Basic Specifications

1.1 Display Specifications

- 1) LCD Display Mode : STN, Negative, Transmissive
- 2) Display Color : Display Data = "1" : Light Gray (*1)
: Display Data = "0" : Dark Blue (*2)
- 3) Viewing Angle : 6 H
- 4) Driving Method : 1/64 duty, 1/9 bias
- 5) Backlight : White LED

Note: *1. Color tone may slightly change by Temperature and Driving Condition.
*2. The Color is defined as the inactive / background color

1.2 Mechanical Specifications

- 1) Outline Dimension : 93.0 x 70.0 x 10.1 MAX.
see attached Outline Drawing for details

1.3 Block Diagram

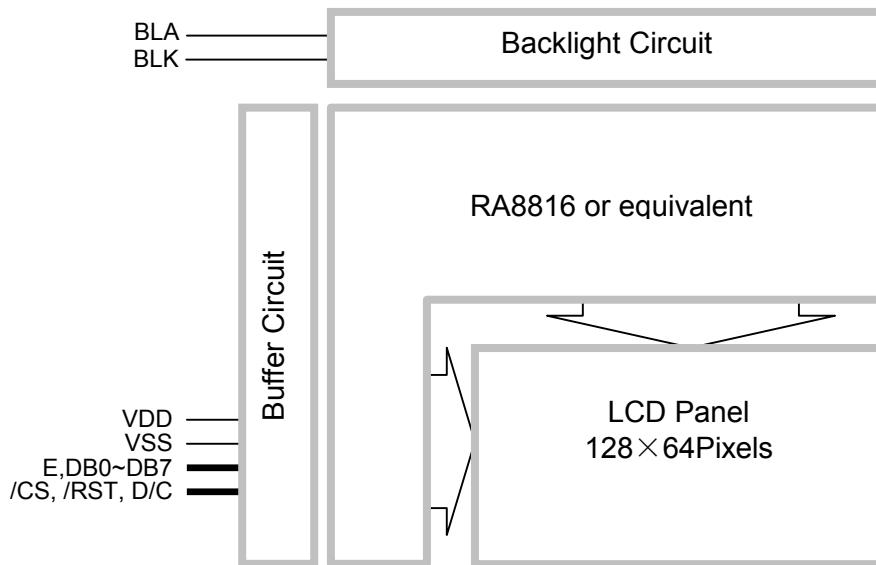

1.4 Terminal Functions

Pin No.	Pin Name	I/O	Descriptions
1	VSS	Power	0V Power Supply, GND
2	VDD	Power	Positive Power Supply
3	NC	-	No connection, leave open
4	D/C	Input	Data/Command Select D/C=HIGH: data on DB0 to DB7 is display data D/C=LOW: data on DB0 to DB7 is control data
5	NC	-	No connection, leave open
6	E	Input	Enable trigger
7	DB0	Input	8-bit data bus input
:	:		
14	DB7		
15	NC	-	No connection, leave open
16	/CS	Input	Chip Select Signal /CS=LOW: Data IO is enabled
17	/RST	Input	Reset Signal: /RST = L, Reset the LCD Module /RST = H, Normal Running
18	NC	NC	No connection, leave open
19	BLA	Power	Positive Power Supply for LED backlight
20	BLK	Power	Negative Power Supply for LED backlight

*Note: 6800 Mode interface write only

2. Absolute Maximum Ratings

Items	Symbol	Min.	Max.	Unit	Condition
Supply Voltage	V_{DD}	-0.3	+6.5	V	$V_{SS} = 0V$
Input Voltage	V_{IN}	0.3	$V_{DD}+0.3$	V	$V_{SS} = 0V$
Operating Temperature	T_{OP}	-20	+70	°C	No Condensation
Storage Temperature	T_{ST}	-30	+80	°C	No Condensation

Cautions:

Any Stresses exceeding the Absolute Maximum Ratings may cause substantial damage to the device. Functional operation of this device at other conditions beyond those listed in the specification is not implied and prolonged exposure to extreme conditions may affect device reliability.

3. Electrical Characteristics

3.1 DC Characteristics

$V_{SS}=0V, V_{DD} =5.0V, T_{OP} =25^{\circ}C$

Items	Symbol	MIN.	TYP.	MAX.	Unit	Applicable Pin
Operating Voltage	V_{DD}	4.7	5.0	5.3	V	VDD
Input High Voltage	V_{IN}	$0.7 \times V_{DD}$	-	VDD	V	DB0~DB7, E, /CS, D/C, /RST
Input Low Voltage	V_{IN}	0	-	$0.3 \times V_{DD}$	V	DB0~DB7, E, /CS, D/C, /RST
Operating Current	I_{DD}	-	11.2	35	mA	VDD

3.2 LED Backlight Circuit Characteristics

$BLK=0V, I_{f_{BLA}}=85mA, T_{OP} =25^{\circ}C$

Items	Symbol	MIN.	TYP.	MAX.	Unit	Applicable Pin
Forward Voltage	$V_{f_{BLA}}$	-	5.0	-	V	BLA
Forward Current	$I_{f_{BLA}}$	-	85	100	mA	BLA

Cautions:

Exceeding the recommended driving current could cause substantial damage to the backlight and shorten its lifetime.

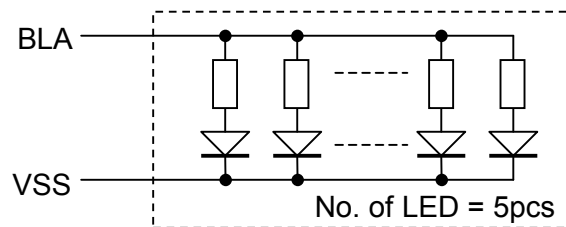

3.3 AC Characteristics

$V_{SS}=0V, V_{DD}=5.0V, T_{OP}=25^{\circ}C$

Item	Signal	Symbol	Condition	MIN.	MAX.	Unit	
Address Setup Time	D/C,/CS	t _{CSW6}		10	-	ns	
Read /Write Set up time	R/W	t _{WEN6}		13	-		
Read /Write hold time		t _{RWH6}		13	-		
Enable access time	EN	t _{AC6}		113	-		
Access Cycle Time (*2)		Command cycle	t _{CYC6}		250		-
			Data cycle		500		-
Write Data Setup Time	DB[7..0]	t _{DS6}	-	13	-		
Write Data Hold Time		t _{DH6}	-	13	-		
Read Data Access Time		t _{OS6}	-	24	63		
Read Data Hold Time		t _{OH6}	-	13	-		

Note: *1. Input signal rise/fall time should be less than 20ns

*2. Bus timing is for one byte transaction only.

For details, please refer to RA8816 datasheet.

*3. R/W Fixed at Low level.

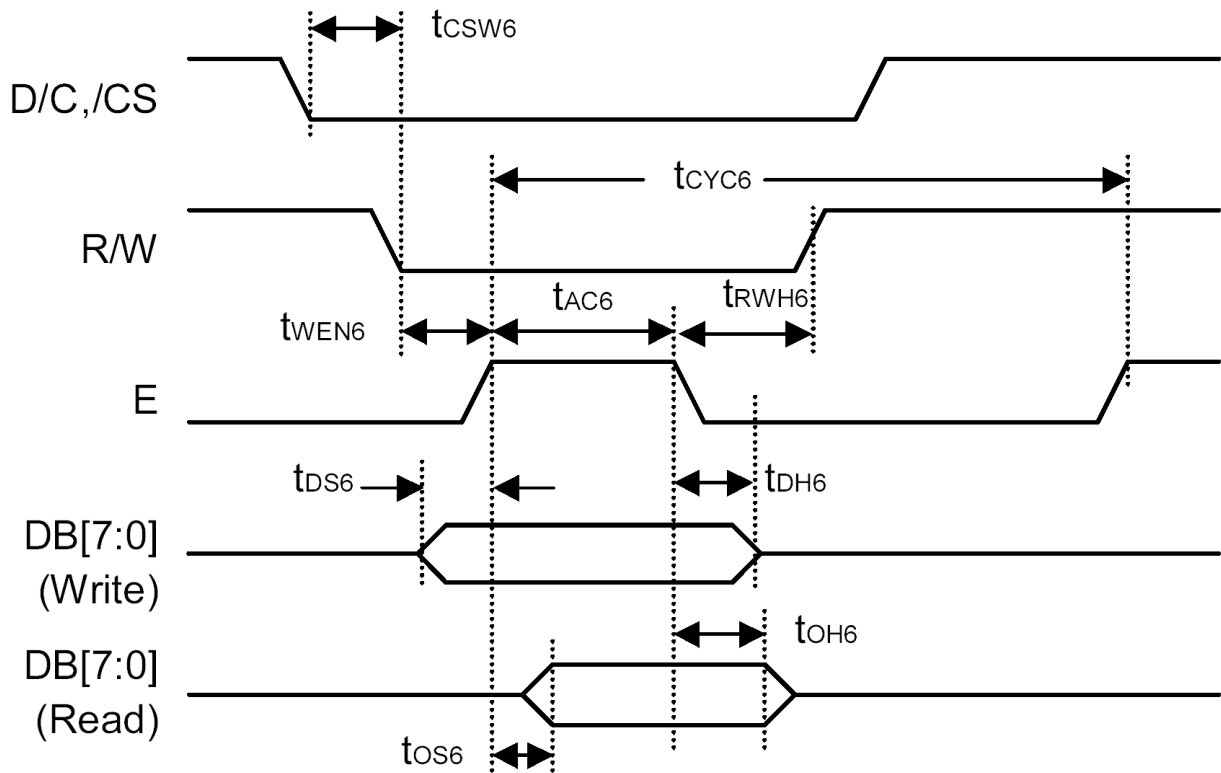

Bus Timing Diagram

3.3.1 Reset Timing

$V_{SS}=0V, V_{DD}=5.0V, T_{OP}=25^{\circ}C$

Item	Symbol	Condition	MIN.	TYP.	MAX.	Unit
Reset setup time	tRST	-	38	-	-	ms
Reset hold time	tRSTH	FCL=100KHZ(Internal RC Oscillator)	190	-	-	ms

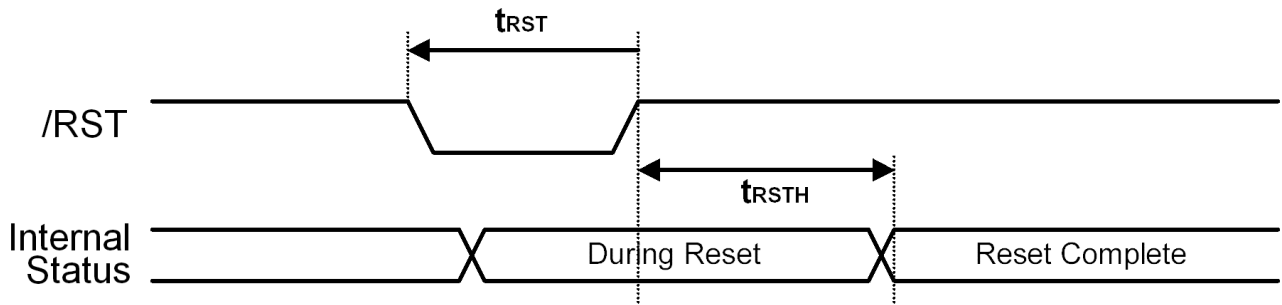

Reset Timing Diagram

4. Function Specifications

4.1 Adjusting the Display Contrast

LCD contrast can be adjusted by software through register [10H]

4.2 Resetting the LCD module

The LCD module should be initialized by using /RST terminal.

While turning on the VDD and VSS power supply, maintain /RST terminal at LOW level. After the power supply stabilized, release the reset terminal (/RST=HIGH)

4.3 Display Pixel Map

1,1 (D7)	1,2 (D6)	1,3 (D5)	1,4 (D4)	1,5 (D3)	---	---	124,1 (D4)	125,1 (D3)	126,1 (D2)	127,1 (D1)	128,1 (D0)
2,1 (D7)	2,2 (D6)	2,3 (D5)	2,4 (D4)	2,5 (D3)	---	---	2,124 (D4)	2,125 (D3)	2,126 (D2)	2,127 (D1)	2,128 (D0)
3,1 (D7)	3,2 (D6)	3,3 (D5)	3,4 (D4)	3,4 (D3)	---	---	3,124 (D4)	3,125 (D3)	3,126 (D2)	3,127 (D1)	3,128 (D0)
:	:	:	:	:	:	:	:	:	:	:	:
:	:	:	:	:	:	:	:	:	:	:	:
:	:	:	:	:	:	:	:	:	:	:	:
62,1 (D7)	62,2 (D6)	62,3 (D5)	62,4 (D4)	62,5 (D3)	---	---	62,124 (D4)	62,125 (D3)	62,126 (D2)	62,127 (D1)	62,128 (D0)
63,1 (D7)	63,2 (D6)	63,3 (D5)	63,4 (D4)	63,5 (D3)	---	---	63,124 (D4)	63,125 (D3)	63,126 (D2)	63,127 (D1)	63,128 (D0)
64,1 (D7)	64,2 (D6)	64,3 (D5)	64,3 (D4)	64,4 (D3)	---	---	64,124 (D4)	64,125 (D3)	64,126 (D2)	64,127 (D1)	64,128 (D0)

Pixel mapping (Top View)

Based on the top view of the LCD module,
 the 1, 1 (x, y) pixel is the upper-left pixel;
 the 64, 128 (x, y) pixel is the lower-right pixel.
 CDIR=1, Common scan reverse;
 SDIR=1, Segment scan reverse;

4.4 Control Data and Command

The LCD module setting is controlled by the internal Register Values.
The Register Address should be addressed and Register Value should be issued when RS=0.

A full command sequence should be as follow.

Steps	/WR	E(Hi->Lo)	RS	Data (DB0~ DB7)
1 st	0	0	0	Register Address
2 nd	0	0	0	Register Value

4.5 Register Table Summary

Reg. Add	Reg. Name	R/W	D7	D6	D5	D4	D3	D2	D1	D0	Descriptions
00h	DWFR	0	B/C	--	NW5	NW4	NW3	NW2	NW1	NW0	Wave Form Select
01h	PWRR	0	SRST	MCLR	--	IO_IEN	KWK	IOWK	DOFF_Z	SLP	Power Control
02h	SYSR	0	LS3	LS2	LS1	LS0	GB_EN	--	RS1	RS0	System Setting
03h	MWMR	0	BMOD1	BMOD0	BIEN	ASCS	BOLD	INV	MD1	MD0	Memory Mode
04h	CURCR	0	H3	H2	H1	H0	--	BLK	CR	CUR_EN	Cursor Control
05h	X-CUR	0	--	--	X5	X4	X3	X2	X1	X0	Cursor X Position
06h	Y-CUR	0	--	Y6	Y5	Y4	Y3	Y2	Y1	Y0	Cursor Y Position
07h	KEYR	0	KSB	KDB1	KDB0	<STB_S_EL	K_AUTO	IRE	<F1/KSTB1	KF0/KSTB0	Key-scan Control
	KSDR	1	SIRQ	KSTB1	KSTB0	KSD4	KSD3	KSD2	KSD1	KSD0	Key-scan Data
08h	SWSXR	0	--	--	--	SSX4	SSX3	SSX2	SSX1	SSX0	X-Scroll Start
09h	SWSYR	0	--	--	SSY5	SSY4	SSY3	SSY2	SSY1	SSY0	Y-Scroll Start
0Ah	SWRXR	0	--	--	--	SRX4	SRX3	SRX2	SRX1	SRX0	X-Scroll Range
0Bh	SWRYR	0	PINV	--	SRY5	SRY4	SRY3	SRY2	SRY1	SRY0	Y-Scroll Range

Register Table Summary (cont')

Reg. Add	Reg. Name	R/W	D7	D6	D5	D4	D3	D2	D1	D0	Descriptions
0Ch	SCOR	0	SL7	SL6	SL5/SR5	SL4/SR4	SL3/SR3	SL2/SR2	SL1/SR1	SL0/SR0	Scroll Unit
0Dh	ASCR	0	SPD3	SPD2	SPD1	SPD0	STP3	STP2	STP1	STP0	Auto Scroll Control
0Eh	SCCR	0	SCR_IM D1	SCR_IM D0	SCR_M D	SBUF	SCR_DI R1	SCR_DI R0	SCR_IN TEN	AUTO_S CR	Scroll Control
0Fh	ISR	1	BF	--	--	--	IO_I	SCR_I	KI	BI	Interrupt Status
10h	CSTR	0	BR2	BR1	BR0	CT4	CT3	CT2	CT1	CT0	Contrast
11h	DRCR_A	0	DWH7	DWH6	DWH5	DWH4	DWH3	DWH2	DWH1	DWH0	Driver Control
12h	DRCR_B	0	CK_BS1	CK_BS0	RR2	RR1	RR0	IRS	HD1	HD0	Driver Control
13h	BLTR	0	BLK_EN	PBK_EN	--	INV	BLT3	BLT2	BLT1	BLT0	Blink Setting
14h	IODR	0	OE7	OE6	OE5	OE4	OE3	OE2	OE1	OE0	I/O Port Direction
15h	IODAR	0	IOD7	IOD6	IOD5	IOD4	IOD3	IOD2	IOD1	IOD0	I/O Port Data
16h	ELCR	0	EL_EN	--	--	--	ELT3	ELT2	ELT1	ELT0	EL Control
17h	CGMI	0	--	--	--	--	UMI2	UMI1	UMI0		Create Font Select
18h	CGMD	0	CGMD7	CGMD6	CGMD5	CGMD4	CGMD3	CGMD2	CGMD1	CGMD0	Create Font Data

Note:

*1. For the details, please refer to RA8816 Data sheet.

4.6 Initialization Setting Example

The following setting should be issue to LCD module after hardware reset.
(example could be adjusted, if necessary.)

Register Add	Register Name	Value (binary)	Value (hex)	Note
00h	DWFR	0000 0000	00	B wave form
01h	PWRR	0000 00010	02	Clear display RAM,Display on
02h	SYSR	1000 1010	8b	Segment=144 common=64 GB code used
04h	CURCR	1111 0101	F5	Cursor Height = 16 pixels Cursor on and blink
10h	CSTR	1000 1111	8f	Contrast control
11h	DRCR_A	1111 0011	F3	Internal voltage booster, regulator, follower used Seg&Com scan reverse
12h	DRCR_B	0010 0111	37	Booster frequency =50KHz 4 step Largest driving current
13h	BLTR	0000 0000	00	Normal display

Note:

Others un-mentioned registers are using its hardware reset default value.

5. Design and Handling Precaution

1. The LCD panel is made by glass. Any mechanical shock (eg. dropping from high place) will damage the LCD module.
2. Do not add excessive force on the surface of the display, which may cause the Display color change abnormally.
3. The polarizer on the LCD is easily get scratched. If possible, do not remove the LCD protective film until the last step of installation.
4. Never attempt to disassemble or rework the LCD module.
5. Only Clean the LCD with Isopropyl Alcohol or Ethyl Alcohol. Other solvents (eg. water) may damage the LCD.
6. When mounting the LCD module, make sure that it is free from twisting, warping and distortion.
7. Ensure to provide enough space (with cushion) between case and LCD panel to prevent external force adding on it, or it may cause damage to the LCD or degrade the display result.
8. Only hold the LCD module by its side. Never hold LCD module by add force on the heat seal or TAB.
9. Never add force to component of the LCD module. It may cause invisible damage or degrade of the reliability.
10. LCD module could be easily damaged by static electricity. Be careful to maintain an optimum anti-static work environment to protect the LCD module.
11. When peeling off the protective film from LCD, static charge may cause abnormal display pattern. It is normal and will resume to normal in a short while.
12. Take care and prevent get hurt by the LCD panel sharp edge.
13. Never operate the LCD module exceed the absolute maximum ratings.
14. Keep the signal line as short as possible to prevent noisy signal applying to LCD module.
15. Never apply signal to the LCD module without power supply.
16. IC chip (eg. TAB or COG) is sensitive to the light. Strong lighting environment could possibly cause malfunction. Light sealing structure casing is recommend.
17. LCD module reliability may be reduced by temperature shock.
18. When storing the LCD module, avoid exposure to the direct sunlight, high humidity, high temperature or low temperature. They may damage or degrade the LCD module