



深圳市拓普微科技开发有限公司
SHENZHEN TOPWAY TECHNOLOGY CO., LTD.

LM6069DFW

LCD Module User Manual

Prepared by: zhou Date:2012-06-05	Checked by: Date:	Approved by: Date:
---	----------------------------------	-----------------------------------

Rev.	Descriptions	Release Date
0.1	Preliminary release	2010-3-5
0.2	Revise Descriptions	2012-06-05

Table of Content

1. Basic Specifications	3
1.1 Display Specifications	3
1.2 Mechanical Specifications	3
1.3 Block Diagram	3
2. Terminal Functions	4
3. Absolute Maximum Ratings	5
4. Electrical Characteristics	5
4.1 DC Characteristics	5
4.2 LED Backlight Circuit Characteristics	5
4.3 AC Characteristics	6
4.4 Reset Timing	8
5. Function specifications	9
5.1 Basic Setting	9
5.2 Resetting the LCD module	9
5.3 Display Memory Map	9
5.4 Display Commands	10
5.5 Display Commands (continue)	11
5.6 Design and Handling Precaution	12

1. Basic Specifications

1.1 Display Specifications

- 1) LCD Display Mode : STN-Blue, Negative, Transmissive
- 2) Display Color : Display Data = "1" : Light Gray (*1)
: Display Data = "0" : Dark Blue (*2)
- 3) Viewing Angle : 6H
- 4) Driving Method : 1/65 duty, 1/9 bias
- 5) Backlight : While LED backlight

Note:

*1. Color tone may slightly change by Temperature and Driving Condition.

*2. The Color is defined as the inactive / background color

*3. Fine Contrast adjustment function is necessary in the application design for optimal display result

1.2 Mechanical Specifications

- 1) Outline Dimension : 96.0 x 38.3 x 11.0MAX (mm)
(See attached Outline Drawing for details)

1.3 Block Diagram

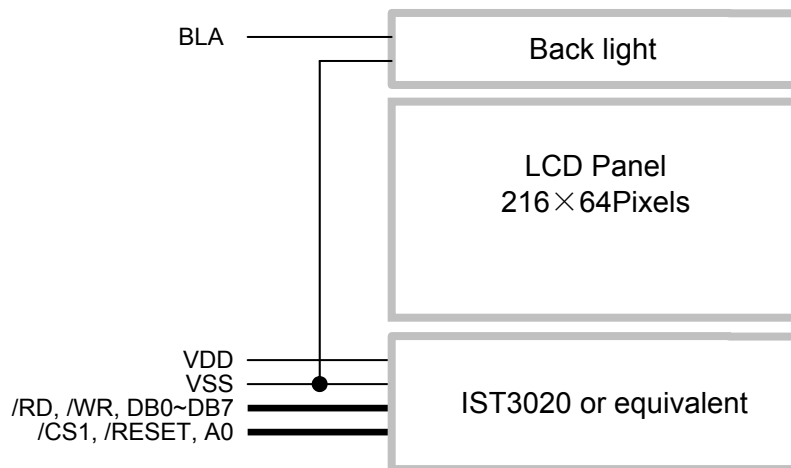

2. Terminal Functions

PIN NO.	PIN Name	I/O	Descriptions			
			8-bit parallel 8080 mode	8-bit parallel 6800 mode	Serial mode	
1	VSS	Supply	Negative power supply,0V			
2	VDD	Supply	Positive power supply			
3	/CS1	Input	Chip Select /CS1=L, enable access to the LCD module /CS1=H, disable access to the LCD module			
4	/RESET	Input	Reset signal /RESET = L, Initialization is executed /RESET = H, Normal running.			
5	A0	Input	Register Select A0 = H, Transferring the Display Data A0 = L, Transferring the Control Data			
6	/WR(R/W)	Input	/WR=L→H, /RD=H; Data or Instruction latch into the LCD module	R/W=H,E=H; Data or Status read from the LCD module R/W=L,E=H→L; Data or Status latch into the LCD module	Not used, Leave open or pull Hi	
7	/RD(E)	Input	/WR=H, /RD=L; Data or Status read form the LCD module			
8	DB0	I/O	8-bit Data bus; Three state I/O terminal for display data or instruction data when /CS1=H, DB0~DB7=High Impedance		DB5-DB0 connect to VDD	
:	:	I/O				
13	DB5	I/O				
14	DB6(SCL):	I/O				Serial clock input
15	DB7(SI)	I/O				Serial data input
16	BLA	Power	Backlight Positive Supply			

Interface setting:

Setting	8080 mode(Default)	6800 mode	SPI mode
JP1	OPEN	CLOSE	OPEN
JP2	CLOSE	OPEN	OPEN
JP3	CLOSE	CLOSE	OPEN
JP4	OPEN	OPEN	CLOSE
JP7~JP14	OPEN	OPEN	CLOSE

3. Absolute Maximum Ratings

Items	Symbol	Min.	Max.	Unit	Condition
Supply Voltage	V_{DD}	-0.3	+3.6	V	$V_{SS} = 0V$
Input Voltage	V_{IN}	-0.2	$V_{DD}+0.2$	V	$V_{SS} = 0V$
Operating Temperature	T_{OP}	-20	+70	°C	No Condensation
Storage Temperature	T_{ST}	-30	+80	°C	No Condensation

Cautions:

Any Stresses exceeding the Absolute Maximum Ratings may cause substantial damage to the device. Functional operation of this device at other conditions beyond those listed in the specification is not implied and prolonged exposure to extreme conditions may affect device reliability.

4. Electrical Characteristics

4.1 DC Characteristics

$V_{SS}=0V, V_{DD}=3.3V, T_{OP}=25^{\circ}C$

Items	Symbol	MIN.	TYP.	MAX.	Unit	Condition / Application Pin
Operating Voltage	V_{DD}	3.0	-	3.6	V	VDD
Input High Voltage	V_{IH}	$0.85 \times V_{DD}$	-	V_{DD}	V	/RESET, /CS1, A0,
Input Low Voltage	V_{IL}	V_{SS}	-	$0.15 \times V_{DD}$	V	/WR, /RD, DB0~DB7
Operating Current	I_{DD}	-	0.3	2.3	mA	VDD

4.2 LED Backlight Circuit Characteristics

$V_{BLK}=0V, I_{f_{BLA}}=68mA, T_{OP}=25^{\circ}C$

Items	Symbol	MIN.	TYP.	MAX.	Unit	Applicable Pin
Forward Voltage	$V_{f_{BLA}}$	-	3.3	-	V	BLA
Forward Current	$I_{f_{BLA}}$	-	68	80	mA	BLA

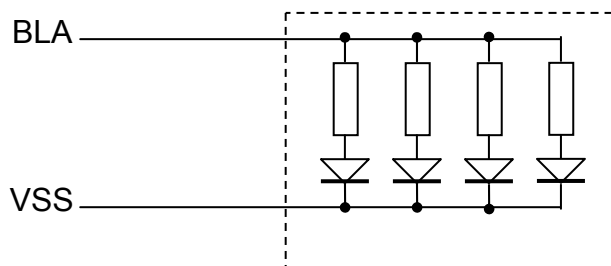

4.3 AC Characteristics

4.3.1 8080 Mode System Bus Timing

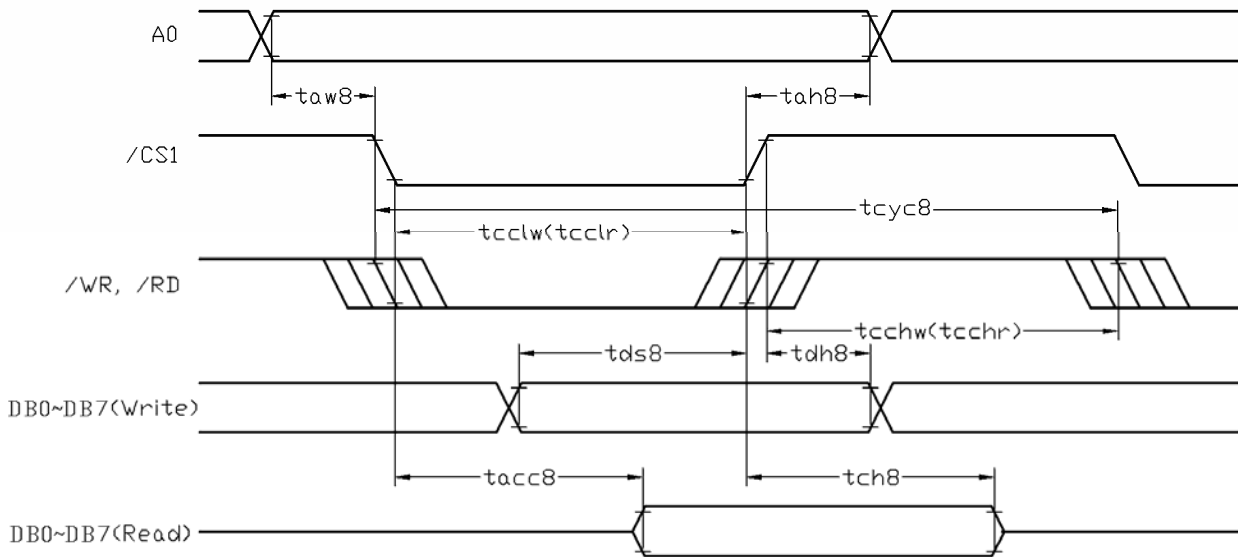

$V_{SS}=0V, V_{DD}=3.3V, T_{OP}=25^{\circ}C$

Item	Symbol	MIN.	TYP.	MAX.	Unit
System cycle time	tcyc8	430	-	-	ns
Address setup time (A0)	taw8	10	-	-	ns
Address hold time (A0)	tah8	10	-	-	ns
Control LOW pulse width (/RD)	tcclr	86	-	-	ns
Control LOW pulse width (/WR)	tcclw	86	-	-	ns
Control HIGH pulse width (/RD)	tchr	86	-	-	ns
Control HIGH pulse width (/WR)	tcchw	86	-	-	ns
Data setup time	tds8	58	-	-	ns
Data hold time	tdh8	22	-	-	ns
/RD access time (*2)	tacc8	-	-	200	ns
Output disable time (*2)	tch8	7	-	143	ns

Note:

*1. Input signal rise/fall time should be less than 15ns .

*2.All timing is using 20% and 80% of VDD as the reference.

4.3.2 6800 Mode System Bus Timing

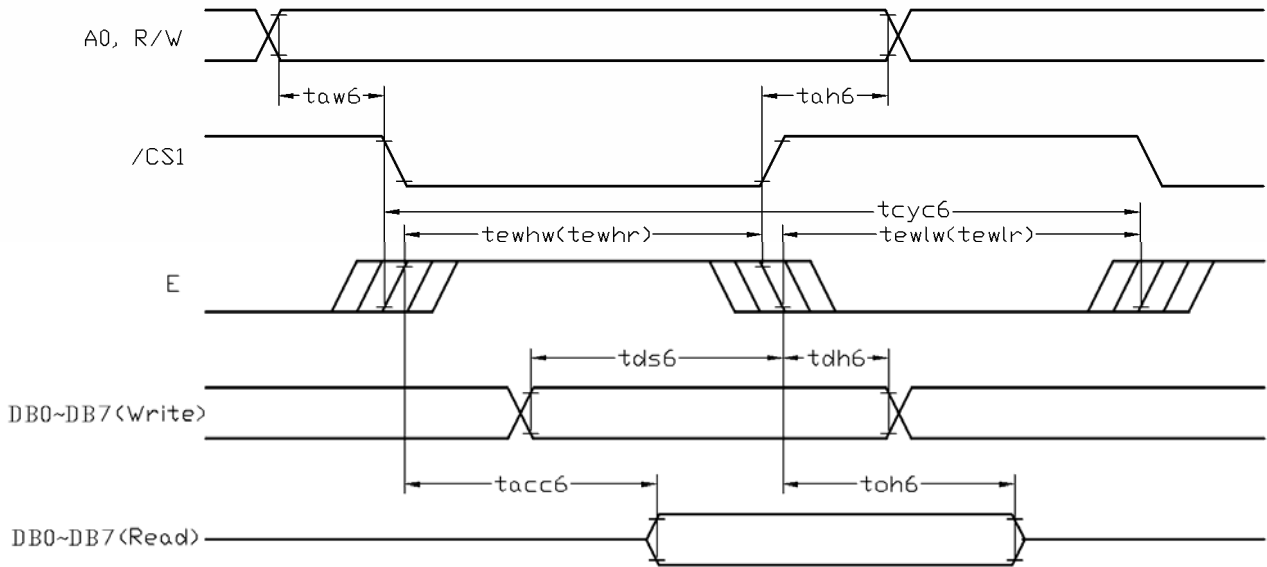

$V_{SS}=0V, V_{DD}=3.3V, T_{OP}=25^{\circ}C$

Item	Symbol	MIN.	TYP.	MAX.	Unit
System cycle time	tcyc6	430	-	-	ns
Address setup time (A0)	taw6	10	-	-	ns
Address hold time (A0)	tah6	10	-	-	ns
Control LOW pulse width (R/W)	tewlr	-	-	-	ns
Control LOW pulse width (R/W)	tewlw	-	-	-	ns
Control HIGH pulse width (/RD)	tewhr	86	-	-	ns
Control HIGH pulse width (R/W)	tewhw	86	-	-	ns
Data setup time	tds6	58	-	-	ns
Data hold time	tdh6	22	-	-	ns
/RD access time (*2)	tacc6	-	-	200	ns
Output disable time (*2)	toh6	7	-	143	ns

Note:

*1. Input signal rise/fall time should be less than 15ns .

*2. CL=100pF

*3.All timing is using 20% and 80% of VDD as the reference.

4.3.3 Serial Mode Interface

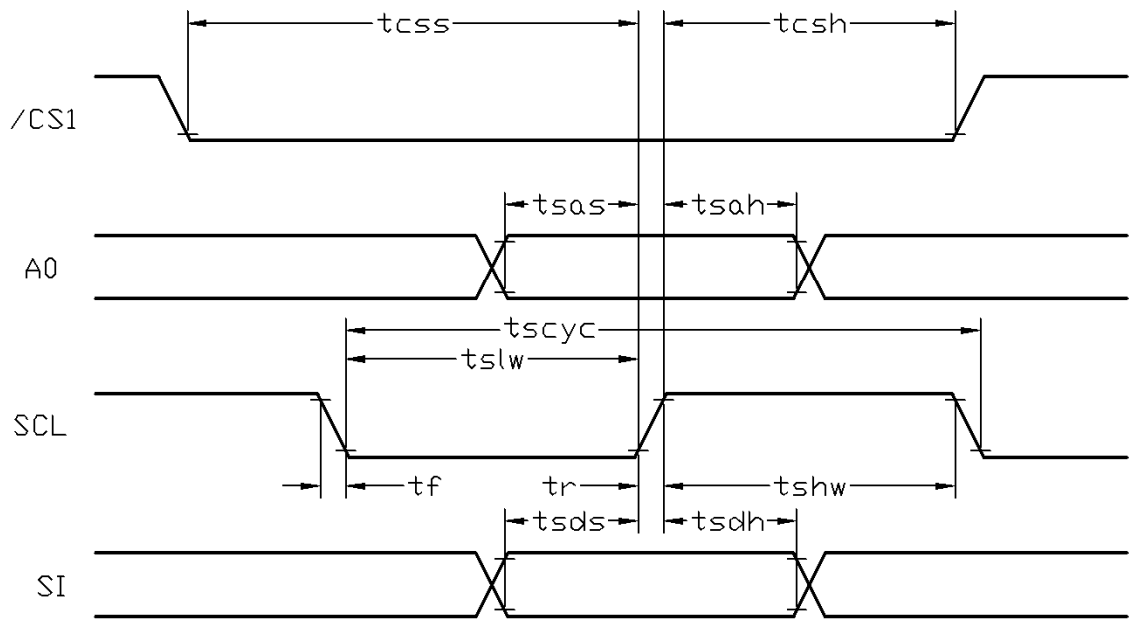

V_{SS}=0V, V_{DD}=3.3V, T_{OP}=25°C

Item	Symbol	MIN.	TYP.	MAX.	Unit
Serial Clock Period	tscyc	357	-	-	ns
Address setup time (A0)	tsas	214	-	-	ns
Address hold time (A0)	tsah	214	-	-	ns
SCL "H" pulse width	tshw	143	-	-	ns
SCL "L" pulse width	tslw	143	-	-	ns
Data setup time	tsds	143	-	-	ns
Data hold time	tsdh	143	-	-	ns
CS-SCL time	tcsh	214	-	-	ns
CS-SCL time	tcsh	214	-	-	ns

Note:

*1. Input signal rise/fall time should be less than 15ns .

*2. CL=100pF

*3.All timing is using 20% and 80% of VDD as the reference.

4.4 Reset Timing

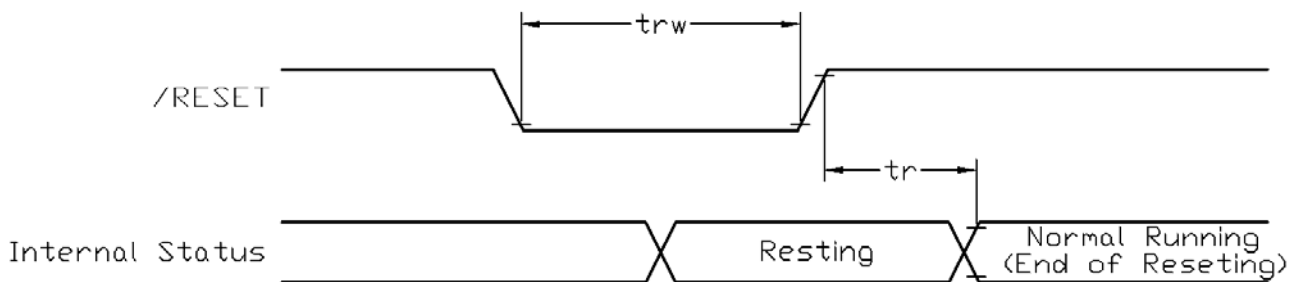

V_{SS}=0V, V_{DD}=3.3V, T_{OP}=25°C

Item	Symbol	MIN.	TYP.	MAX.	Unit
Reset time	tr	-	-	1.5	μs
Reset LOW pulse width	trw	1.5	-	-	μs

Note:

*1.All timing is using 20% and 80% of VDD as the reference.

5. Function specifications

5.1 Basic Setting

Basic Setting

To drive the LCD module correctly and provide normally display, please use the following setting

- ADC = 0 (normal)
- SHL select = 1 (reverse)
- LCD Bias Select = 1/9
- Initial Display Line = 0
- Entire Display ON/OFF = OFF (normal)
- Reverse Display ON/OFF = OFF (normal)
- Set Power Control Set:
voltage follower = ON, voltage converter = ON, voltage regulator = ON
- Built-in OSC = ON
- Display ON/OFF = ON

Note:

*1. These setting/commands should issue the LCD module while start up.

*2. See the Display Commands section for details.

5.2 Resetting the LCD module

The LCD module should be initialized by using /RESET terminal.

While turning on the VDD and VSS power supply, maintain /RES terminal at LOW level. After the power supply stabilized, release the reset terminal (/RESET=HIGH)

5.3 Display Memory Map

Page address	data	LCD Display (front view)		
0	D0 : D7			
1	D0 : D7			
2	D0 : D7			
3	D0 : D7			
4	D0 : D7			
5	D0 : D7			
6	D0 : D7			
7	D0 : D7			
Column Address		00H	→	D7H

Note:

*1. ADC = 0 (normal)

*2. SHL Selection = 1 (reverse)

*3. Initial Display Line = 0

5.4 Display Commands

× : Don't care

INSTRUCTION	A0	RW	DB7	DB6	DB5	DB4	DB3	DB2	DB1	DB0	Description
Display ON / OFF	0	0	1	0	1	0	1	1	1	DON	Turn on/off LCD panel When DON = 0 : display OFF When DON = 1 : display ON
Initial display line	0	0	0	1	ST5	ST4	ST3	ST2	ST1	ST0	Specify DDRAM line for COM0
Set page address	0	0	1	0	1	1	P3	P2	P1	P0	Set page address
Set column address MSB	0	0	0	0	0	1	Y7	Y6	Y5	Y4	Set column address MSB
Set column address LSB	0	0	0	0	0	0	Y3	Y2	Y1	Y0	Set column address LSB
Read status	0	1	BUSY	ADCB	ON/OFF	RESETB	0	0	0	0	Read the internal status
Write display data	1	0	Write data								Write data into DDRAM
Read display data	1	1	Read data								Read data from DDRAM
ADC select	0	0	1	0	1	0	0	0	0	ADC	Select SEG output direction When ADC = 0 : normal direction (SEG0 → SEG223) when ADC = 1 : reverse direction (SEG223 → SEG0)
Reverse display ON / OFF	0	0	1	0	1	0	0	1	1	REV	Select normal / reverse display When REV = 0 : normal display When REV = 1 : reverse display
Entire display ON / OFF	0	0	1	0	1	0	0	1	0	EON	Select normal / entire display ON When EON = 0 : normal display When EON = 1 : entire display ON
LCD bias select	0	0	1	0	1	0	0	0	1	BIAS	Select LCD bias
Set modify-read	0	0	1	1	1	0	0	0	0	0	Set modify-read mode
Reset modify-read	0	0	1	1	1	0	1	1	1	0	Release modify-read mode
Reset	0	0	1	1	1	0	0	0	1	0	Initialize the internal functions
SHL select	0	0	1	1	0	0	SHL	×	×	×	Select COM output direction When SHL = 0 : normal direction (COM0 → COM63) When SHL = 1 : reverse direction (COM63 → COM0)
Power control	0	0	0	0	1	0	1	VC	VR	VF	Control power circuit operation
Regulator resistor select	0	0	0	0	1	0	0	R2	R1	R0	Select internal resistance ratio of the regulator resistor
Set reference voltage mode	0	0	1	0	0	0	0	0	0	1	Set reference voltage mode
Set reference voltage mode	0	0	×	×	SV5	SV4	SV3	SV2	SV1	SV0	Set reference voltage register
Set static indicator mode	0	0	1	0	1	0	1	1	0	SM	Set static indicator mode
Set static indicator register	0	0	×	×	×	×	×	×	S1	S0	Set static indicator register
Power save	0	0	1	0	1	0	1	0	0	SAV	Select power save mode When SAV = 0 : Stand-by When SAV = 1 : Sleep
Power save reset	0	0	1	1	1	0	0	0	0	1	Reset power save
Set n-Line reversal drive register	0	0	0	0	1	1	NL3	NL2	NL1	NL0	Set the number of line reversal drive line

Note: *1. Do not use any other command not listed, or the system malfunction may result.
*2. For the details of the Display Commands, please refer to IST3020 data sheet.

5.5 Display Commands (continue)

n-Line reversal drive reset	0	0	1	1	1	0	0	1	0	0	Reset the line reversal drive
Built-in oscillator ON	0	0	1	0	1	0	1	0	1	1	Start the built-in oscillator circuit
External capacitor discharge	0	0	0	1	1	1	0	DISC			DISC = 000 (enable) DISC = 111 (disable)
NOP	0	0	1	1	1	0	0	0	1	1	Non-Operation command
Test	0	0	1	1	1	1	x	x	x	x	Don't use this instruction
Set OTP program	0	0	1	0	0	1	0	0	0	0	Set OTP program mode
OTP program control	0	0	OTPA DJ	OTPP ON	x	x	x	x	x	x	OTP control option OTPADJ = 1:OTP use OTPADJ = 0:OTP ignore OTPPON = 1:OTP program enable OTPPON =0:OTP program disable
Set contrast offset (1)	0	0	1	0	0	1	0	0	0	1	Set contrast offset mode (1)
	0	0	x	x	CTA5	CTA4	CTA3	CAT2	CAT1	CTA0	Set contrast offset register (1)
Set contrast offset (2)	0	0	1	0	0	1	0	0	1	0	Set contrast offset mode (2)
	0	0	x	x	x	CTB4	CTB3	CTB2	CTB1	CTB0	Set contrast offset register (2)
Set contrast offset (3)	0	0	1	0	0	1	0	0	1	1	Set contrast offset mode (3)
	0	0	x	x	x	CTC4	CTC3	CTC2	CTC1	CTC0	Set contrast offset register (3)
Read contrast offset(1)	0	0	1	0	0	0	1	1	0	0	Set contrast offset read mode (1)
	0	1	x	x	CTA5	CTA4	CTA3	CTA2	CTA1	CTA0	Read contrast offset(1)
Read contrast offset(2)	0	0	1	0	0	0	1	1	0	1	Set contrast offset read mode (2)
	0	1	x	x	x	CTB4	CTB3	CTB2	CTB1	CTB0	Read contrast offset(2)
Read contrast offset(3)	0	0	1	0	0	0	1	1	1	0	Set contrast offset read mode (3)
	0	1	x	x	x	CTC4	CTC3	CTC2	CTC1	CTC0	Read contrast offset(3)

Note: *1. Do not use any other command not listed, or the system malfunction may result.
*2. For the details of the Display Commands, please refer to IST3020 data sheet.

5.5.1 Power off the LCD Module

It recommends that enter Power Save mode before power off the LCD module.

5.5.2 Refreshing The LCD Module

It recommends that the operating modes and display contents be refreshed periodically to prevent the effect of unexpected noise.

5.6 Design and Handling Precaution

1. The LCD panel is made by glass. Any mechanical shock (eg. dropping from high place) will damage the LCD module.
2. Do not add excessive force on the surface of the display, which may cause the Display color change abnormally.
3. The polarizer on the LCD is easily get scratched. If possible, do not remove the LCD protective film until the last step of installation.
4. Never attempt to disassemble or rework the LCD module.
5. Only Clean the LCD with Isopropyl Alcohol or Ethyl Alcohol. Other solvents (eg. water) may damage the LCD.
6. When mounting the LCD module, make sure that it is free from twisting, warping and distortion.
7. Ensure to provide enough space (with cushion) between case and LCD panel to prevent external force adding on it, or it may cause damage to the LCD or degrade the display result.
8. Only hold the LCD module by its side. Never hold LCD module by add force on the heat seal or TAB.
9. Never add force to component of the LCD module. It may cause invisible damage or degrade of the reliability.
10. LCD module could be easily damaged by static electricity. Be careful to maintain an optimum anti-static work environment to protect the LCD module.
11. When peeling off the protective film from LCD, static charge may cause abnormal display pattern. It is normal and will resume to normal in a short while.
12. Take care and prevent get hurt by the LCD panel sharp edge.
13. Never operate the LCD module exceed the absolute maximum ratings.
14. Keep the signal line as short as possible to prevent noisy signal applying to LCD module.
15. Never apply signal to the LCD module without power supply.
16. IC chip (eg. TAB or COG) is sensitive to the light. Strong lighting environment could possibly cause malfunction. Light sealing structure casing is recommend.
17. LCD module reliability may be reduced by temperature shock.
18. When storing the LCD module, avoid exposure to the direct sunlight, high humidity, high temperature or low temperature. They may damage or degrade the LCD module