

LM7131 Tiny High Speed Single Supply Operational Amplifier

Check for Samples: [LM7131](#)

FEATURES

- **Tiny SOT23-5 Package Saves Space-Typical Circuit Layouts Take Half the Space of SOIC-8 Designs.**
- **Guaranteed Specs at 3V, 5V, and $\pm 5V$ Supplies**
- **Typical Supply Current 7.0 mA at 5V, 6.5 mA at 3V**
- **4V Output Swing with +5V Single Supply**
- **Typical Total Harmonic Distortion of 0.1% at 4 MHz**
- **70 MHz Gain-Bandwidth Product**
- **90 MHz -3 dB Bandwidth at 3V and 5V, Gain = +1**
- **Designed to Drive Popular Video A/D Converters**
- **40 mA Output can Drive 50 Ω Loads**
- **Differential Gain and Phase 0.25% and 0.75° at $A_V = +2$**

APPLICATIONS

- **Driving Video A/D Converters**
- **Video Output for Portable Computers and PDAs**
- **Desktop Teleconferencing**
- **High Fidelity Digital Audio**
- **Video Cards**

CONNECTION DIAGRAM

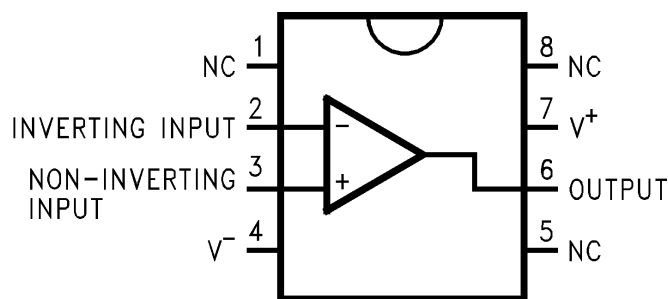

Figure 1. 8-Pin SOIC-8-Top View

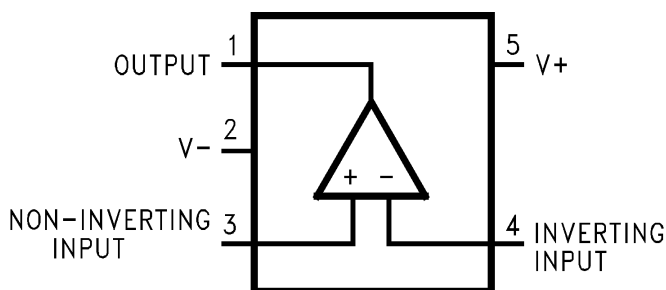

Figure 2. 5-Pin SOT23-5-Top View



Please be aware that an important notice concerning availability, standard warranty, and use in critical applications of Texas Instruments semiconductor products and disclaimers thereto appears at the end of this data sheet.

All trademarks are the property of their respective owners.



These devices have limited built-in ESD protection. The leads should be shorted together or the device placed in conductive foam during storage or handling to prevent electrostatic damage to the MOS gates.

ABSOLUTE MAXIMUM RATINGS ⁽¹⁾⁽²⁾

ESD Tolerance ⁽³⁾	2000V
Differential Input Voltage	±2.0
Voltage at Input/Output Pin	(V ⁺)+0.1V, (V ⁻) - 0.3V
Supply Voltage (V ⁺ - V ⁻)	12V
Current at Input Pin	±5 mA
Current at Output Pin ⁽⁴⁾	±80 mA
Current at Power Supply Pin	±80 mA
Lead Temperature (soldering, 10 sec)	260°C
Storage Temperature Range	- 65°C to +150°C
Junction Temperature ⁽⁵⁾	150°C

- (1) Absolute maximum Ratings indicate limits beyond which damage to the device may occur. Operating Ratings indicate conditions for which the device is intended to be functional, but specific performance is not ensured. For specifications and the test conditions, see the Electrical characteristics.
- (2) If Military/Aerospace specified devices are required, please contact the Texas Instruments Sales Office/ Distributors for availability and specifications.
- (3) Human body model, 1.5 kΩ in series with 100 pF.
- (4) Applies to both single-supply and split-supply operation. Continuous short circuit operation at elevated ambient temperature can result in exceeding the maximum allowed junction temperature of 150°C.
- (5) The maximum power dissipation is a function of T_{J(max)}, θ_{JA}, and T_A. The maximum allowable power dissipation at any ambient temperature is P_D = (T_{J(max)} - T_A)/θ_{JA}. All numbers apply for packages soldered directly into a PC board.

OPERATING RATINGS

Supply Voltage (V ⁺ - V ⁻)		2.7V ≤ V ≤ 12V
Junction Temperature Range	LM7131AC, LM7131BC	0°C ≤ T _J ≤ + 70°C
Thermal Resistance (θ _{JA})	SOIC-8 Package, 8-Pin Surface Mount	165°C/W
	M05A Package, 5-Pin Surface Mount	325°C/W

3V DC ELECTRICAL CHARACTERISTICS

Unless otherwise specified, all limits specified for $T_J = 25^\circ\text{C}$, $V^+ = 3\text{V}$, $V^- = 0\text{V}$, $V_{\text{CM}} = V_O = V^+/2$ and $R_L = 150\Omega$. **Boldface** limits apply at the temperature extremes.

Symbol	Parameter	Conditions	Typ ⁽¹⁾	LM7131AC	LM7131BC	Units
				Limit ⁽²⁾	Limit ⁽²⁾	
V_{OS}	Input Offset Voltage		0.02	3.5	7	mV
				4	10	max
TCV_{OS}	Input Offset Voltage Average Drift		10			$\mu\text{V}/^\circ\text{C}$
I_B	Input Bias Current		20	35	35	μA
				40	40	max
I_{OS}	Input Offset Current		0.35	3.5	3.5	μA
				5	5	max
CMRR	Common Mode Rejection Ratio	$0\text{V} \leq V_{\text{CM}} \leq 0.85\text{V}$ (Video Levels)	75	60	60	dB
		55	55	min		
CMRR	Common Mode Rejection Ratio	$0.85\text{V} \leq V_{\text{CM}} \leq 1.7\text{V}$ (Mid-Range)	70	55	55	dB
		50	50	min		
+PSRR	Positive Power Supply Rejection Ratio	$V^+ = 3\text{V}$, $V^- = 0\text{V}$	75	65	65	dB
		$V^+ = 3\text{V}$ to 6.5V	60	60	min	
-PSRR	Negative Power Supply Rejection Ratio	$V^- = -3\text{V}$, $V^+ = 0\text{V}$	75	65	65	dB
		$V^- = -3\text{V}$ to -6.5V	60	60	min	
V_{CM}	Input Common-Mode Voltage Range	$V^+ = 3\text{V}$ For CMRR ≥ 50 dB	0.0	0.0	0.0	V
			0.00	0.00	min	
			2.0	1.70	1.70	V
				1.60	1.60	max
A_{VOL}	Voltage Gain	$R_L = 150\Omega$, $V_O = 0.250\text{V}$ to 1.250V	60	55	55	dB
			50	50		
C_{IN}	Common-Mode Input Capacitance		2			pF
V_O	Output Swing High	$V^+ = 3\text{V}$, $R_L = 150\Omega$ terminated at 0V	2.6	2.3	2.3	V
		2.0	2.0	min		
	Low	$V^+ = 3\text{V}$, $R_L = 150\Omega$ terminated at 0V	0.05	0.15	0.15	V
		0.20	0.20	max		
High	$V^+ = 3\text{V}$, $R_L = 150\Omega$ terminated at 1.5V	2.6	2.3	2.3	V	
		2.0	2.0	min		
Low	$V^+ = 3\text{V}$, $R_L = 150\Omega$ terminated at 1.5V	0.5	0.8	0.8	V	
		1.0	1.0	max		
V_O	Output Swing High	$V^+ = 3\text{V}$, $R_L = 600\Omega$ terminated at 0V	2.73			V
						max
V_O	Output Swing Low	$V^+ = 3\text{V}$, $R_L = 600\Omega$ terminated at 0V	0.06			V
						max
I_{SC}	Output Short Circuit Current	Sourcing, $V_O = 0\text{V}$	65	45	45	mA
		40	40	min		
Sinking, $V_O = 3\text{V}$		40	25	25	mA	
		20	20	min		
I_S	Supply Current	$V^+ = +3\text{V}$	6.5	9.0	9.0	mA
			9.5	9.5	max	

(1) Typical values represent the most likely parametric norm.

(2) All limits are specified by testing or statistical analysis.

3V AC ELECTRICAL CHARACTERISTICS

Unless otherwise specified, all limits specified for $T_J = 25^\circ\text{C}$, $V^+ = 3\text{V}$, $V^- = 0\text{V}$, $V_{\text{CM}} = V_O = V^+/2$ and $R_L = 150\Omega$. **Boldface** limits apply at the temperature extremes.

Symbol	Parameter	Conditions	Typ ⁽¹⁾	LM7131AC	LM7131BC	Units
				Limit ⁽²⁾	Limit ⁽²⁾	
T.H.D.	Total Harmonic Distortion	$F = 4\text{ MHz}$, $A_V = +2$ $R_L = 150\Omega$, $V_O = 1.0V_{\text{PP}}$	0.1			%
	Differential Gain	⁽³⁾	0.45			%
	Differential Phase	⁽³⁾	0.6			°
SR	Slew Rate	$R_L = 150\Omega$, $C_L = 5\text{ pF}$ ⁽⁴⁾	120			V/ μS
SR	Slew Rate	$R_L = 150\Omega$, $C_L = 20\text{ pF}$ ⁽⁴⁾	100			V/ μS
GBW	Gain-Bandwidth Product		70			MHz
	Closed-Loop – 3 dB Bandwidth		90			MHz

(1) Typical values represent the most likely parametric norm.

(2) All limits are specified by testing or statistical analysis.

(3) Differential gain and phase measured with a 4.5 MHz signal into a 150 Ω load, Gain = +2.0, between 0.6V and 2.0V output.

(4) Connected as voltage follower with 1.5V step input. Number specified is the slower of the positive and negative slew rates. $V^+ = 3\text{V}$ and $R_L = 150\Omega$ connected to 1.5V. Amp excited with 1 kHz to produce $V_O = 1.5 V_{\text{PP}}$.

5V DC ELECTRICAL CHARACTERISTICS

Unless otherwise specified, all limits specified for $T_J = 25^\circ\text{C}$, $V^+ = 5\text{V}$, $V^- = 0\text{V}$, $V_{\text{CM}} = V_O = V^+/2$ and $R_L = 150\Omega$. **Boldface** limits apply at the temperature extremes.

Symbol	Parameter	Conditions	Typ ⁽¹⁾	LM7131AC	LM7131BC	Units
				Limit ⁽²⁾	Limit ⁽²⁾	
V_{OS}	Input Offset Voltage		0.02	3.5 4	7 10	mV max
TCV_{OS}	Input Offset Voltage Average Drift		10			$\mu\text{V}/^\circ\text{C}$
I_B	Input Bias Current		20	35 40	35 40	μA max
I_{OS}	Input Offset Current		0.35	3.5 5	3.5 5	μA max
CMRR	Common Mode Rejection Ratio	$0\text{V} \leq V_{\text{CM}} \leq 1.85\text{V}$ (Video Levels)	75	65 60	65 60	dB min
CMRR	Common Mode Rejection Ratio	$1.85\text{V} \leq V_{\text{CM}} \leq 3.7\text{V}$ (Mid-Range)	70	55 50	55 50	dB min
+ PSRR	Positive Power Supply Rejection Ratio	$V^+ = 5\text{V}$, $V^- = 0\text{V}$ $V^+ = 5\text{V}$ to 10V	75	65 60	65 60	dB min
- PSRR	Negative Power Supply Rejection Ratio	$V^- = -5\text{V}$, $V^+ = 0\text{V}$ $V^- = -5\text{V}$ to -10V	75	65 60	65 60	dB min
V_{CM}	Input Common-Mode Voltage Range	$V^+ = 5\text{V}$ For CMRR $\geq 50\text{ dB}$	0.0	- 0.0 0.00	- 0.0 0.00	V min
			4.0	3.70 3.60	3.70 3.60	V max
A_{VOL}	Voltage Gain	$R_L = 150\Omega$, $V_O = 0.250\text{V}$ to 2.250V	70	60 55	60 55	dB min

(1) Typical values represent the most likely parametric norm.

(2) All limits are specified by testing or statistical analysis.

5V DC ELECTRICAL CHARACTERISTICS (continued)

Unless otherwise specified, all limits specified for $T_J = 25^\circ\text{C}$, $V^+ = 5\text{V}$, $V^- = 0\text{V}$, $V_{\text{CM}} = V_O = V^+/2$ and $R_L = 150\Omega$. **Boldface** limits apply at the temperature extremes.

Symbol	Parameter	Conditions	Typ ⁽¹⁾	LM7131AC	LM7131BC	Units
				Limit ⁽²⁾	Limit ⁽²⁾	
C_{IN}	Common-Mode Input Capacitance		2			pF
V_O	Output Swing High	$V^+ = 5\text{V}$, $R_L = 150\Omega$ terminated at 0V	4.5	4.3 4.0	4.3 4.0	V min
	Low	$V^+ = 5\text{V}$, $R_L = 150\Omega$ terminated at 0V	0.08	0.15 0.20	0.15 0.20	V max
	High	$V^+ = 5\text{V}$, $R_L = 150\Omega$ terminated at 2.5V	4.5	4.3 4.0	4.3 4.0	V min
	Low	$V^+ = 5\text{V}$, $R_L = 150\Omega$ terminated at 2.5V	0.5	0.8 1.0	0.8 1.0	V max
V_O	Output Swing High	$V^+ = 5\text{V}$, $R_L = 600\Omega$ terminated at 0V	4.70			V max
V_O	Output Swing Low	$V^+ = 5\text{V}$, $R_L = 600\Omega$ terminated at 0V	0.07			V max
I_{SC}	Output Short Circuit Current	Sourcing, $V_O = 0\text{V}$	65	45 40	45 40	mA min
		Sinking, $V_O = 5\text{V}$	40	25 20	25 20	mA min
I_S	Supply Current	$V^+ = +5\text{V}$	7.0	9.5 10.0	9.5 10.0	mA max

5V AC ELECTRICAL CHARACTERISTICS

Unless otherwise specified, all limits specified for $T_J = 25^\circ\text{C}$, $V^+ = 5\text{V}$, $V^- = 0\text{V}$, $V_{\text{CM}} = V_O = V^+/2$ and $R_L = 150\Omega$. **Boldface** limits apply at the temperature extremes.

Symbol	Parameter	Conditions	Typ ⁽¹⁾	LM7131AC	LM7131BC	Units
				Limit ⁽²⁾	Limit ⁽²⁾	
T.H.D.	Total Harmonic Distortion	$F = 4\text{ MHz}$, $A_V = +2$ $R_L = 150\Omega$, $V_O = 2.0V_{\text{PP}}$	0.1			%
	Differential Gain	⁽³⁾	0.25			%
	Differential Phase	⁽³⁾	0.75			°
SR	Slew Rate	$R_L = 150\Omega$, $C_L = 5\text{ pF}$ ⁽⁴⁾	150			V/ μs
SR	Slew Rate	$R_L = 150\Omega$, $C_L = 20\text{ pF}$ ⁽⁴⁾	130			V/ μs
GBW	Gain-Bandwidth Product		70			MHz
	Closed-Loop -3 dB Bandwidth		90			MHz
e_n	Input-Referred Voltage Noise	$f = 1\text{ kHz}$	11			nV/ $\sqrt{\text{Hz}}$
i_n	Input-Referred Current Noise	$f = 1\text{ kHz}$	3.3			pA/ $\sqrt{\text{Hz}}$

(1) Typical values represent the most likely parametric norm.

(2) All limits are specified by testing or statistical analysis.

(3) Differential gain and phase measured with a 4.5 MHz signal into a 150 Ω load, Gain = +2.0, between 0.6V and 2.0V output.

(4) Connected as Voltage Follower with 4.0V step input. Number specified is the slower of the positive and negative slew rates. $V^+ = 5\text{V}$ and $R_L = 150\Omega$ connected to 2.5V. Amp excited with 1 kHz to produce $V_O = 4 V_{\text{PP}}$.

±5V DC ELECTRICAL CHARACTERISTICS

Unless otherwise specified, all limits specified for $T_J = 25^\circ\text{C}$, $V^+ = 5\text{V}$, $V^- = 5\text{V}$, $V_{\text{CM}} = V_O = 0\text{V}$ and $R_L = 150\Omega$. **Boldface** limits apply at the temperature extremes.

Symbol	Parameter	Conditions	Typ ⁽¹⁾	LM7131AC	LM7131BC	Units
				Limit ⁽²⁾	Limit ⁽²⁾	
V_{OS}	Input Offset Voltage		0.02	3.5	7	mV
				4	10	max
TCV_{OS}	Input Offset Voltage Average Drift		10			$\mu\text{V}/^\circ\text{C}$
I_{B}	Input Bias Current		20	35	35	μA
				40	40	max
I_{OS}	Input Offset Current		0.35	3.5	3.5	μA
				5	5	max
CMRR	Common Mode Rejection Ratio	$-5\text{V} \leq V_{\text{CM}} \leq 3.7\text{V}$	75	65	65	dB
				60	60	min
+PSRR	Positive Power Supply Rejection Ratio	$V^+ = 5\text{V}$, $V^- = 0\text{V}$ $V^+ = 5\text{V}$ to 10V	75	65	65	dB
				60	60	min
-PSRR	Negative Power Supply Rejection Ratio	$V^- = -5\text{V}$, $V^+ = 0\text{V}$ $V^- = -5\text{V}$ to -10V	75	65	65	dB
				60	60	min
V_{CM}	Input Common-Mode Voltage Range	$V^+ = 5\text{V}$, $V^- = -5\text{V}$ For CMRR ≥ 60 dB	-5.0	-5.0	-5.0	V
				-5.0	-5.0	min
				4.0	3.70	3.70
				3.60	3.60	max
A_{VOL}	Voltage Gain	$R_L = 150\Omega$, $V_O = -2.0$ to $+2.0$	70	55	55	dB
				50	50	
C_{IN}	Common-Mode Input Capacitance		2			pF
V_O	Output Swing High Low	$V^+ = 5\text{V}$, $V^- = -5\text{V}$ $R_L = 150\Omega$ terminated at 0V	4.5	4.3	4.3	V
				4.0	4.0	min
				-4.5	-3.5	-3.5
				-2.5	-2.5	max
I_{SC}	Output Short Circuit Current	Sourcing, $V_O = -5\text{V}$	65	45	45	mA
				40	40	min
		Sinking, $V_O = 5\text{V}$	40	25	25	mA
				20	20	min
I_{S}	Supply Current	$V^+ = +5\text{V}$, $V^- = -5\text{V}$	7.5	10.5	10.5	mA
				11.5	11.5	max

(1) Typical values represent the most likely parametric norm.

(2) All limits are specified by testing or statistical analysis.

±5V AC ELECTRICAL CHARACTERISTICS

Unless otherwise specified, all limits specified for $T_J = 25^\circ\text{C}$, $V^+ = 5\text{V}$, $V^- = 5\text{V}$, $V_{\text{CM}} = V_O = 0\text{V}$ and $R_L = 150\Omega$. **Boldface** limits apply at the temperature extremes.

Symbol	Parameter	Conditions	Typ ⁽¹⁾	LM7131AC	LM7131BC	Units
				Limit ⁽²⁾	Limit ⁽²⁾	
T.H.D.	Total Harmonic Distortion	$F = 4\text{ MHz}$, $A_V = -2$ $R_L = 150\Omega$, $V_O = 4.0V_{\text{PP}}$	1.5			%
	Differential Gain	⁽³⁾	0.25			%
	Differential Phase	⁽³⁾	1.0			°
SR	Slew Rate	$R_L = 150\Omega$, $C_L = 5\text{ pF}^{(4)}$	150			V/ μs
SR	Slew Rate	$R_L = 150\Omega$, $C_L = 20\text{ pF}^{(4)}$	130			V/ μs
GBW	Gain-Bandwidth Product		70			MHz
	Closed-Loop -3 dB Bandwidth		90			MHz

- (1) Typical values represent the most likely parametric norm.
- (2) All limits are specified by testing or statistical analysis.
- (3) Differential gain and phase measured with a 4.5 MHz signal into a 150 Ω load, Gain = +2.0, between 0.6V and 2.0V output.
- (4) Connected as Voltage Follower with 4.0V step input. Number specified is the slower of the positive and negative slew rates. $V^+ = 5\text{V}$, $V^- = -5\text{V}$ and $R_L = 150\Omega$ connected to 0V. Amp excited with 1 kHz to produce $V_O = 4\text{ V}_{\text{PP}}$.

TYPICAL PERFORMANCE CHARACTERISTICS

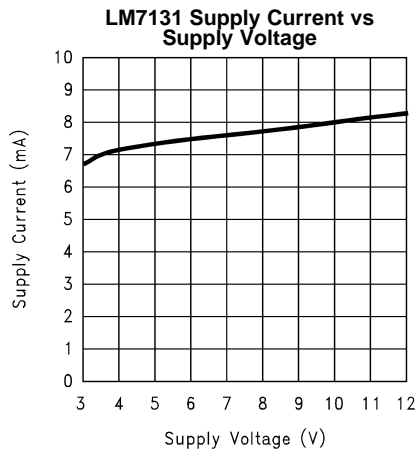

Figure 3.

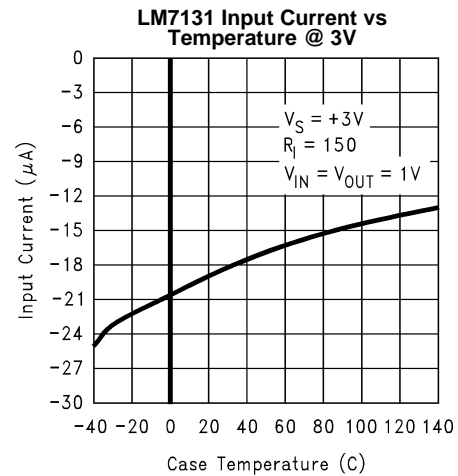

Figure 4.

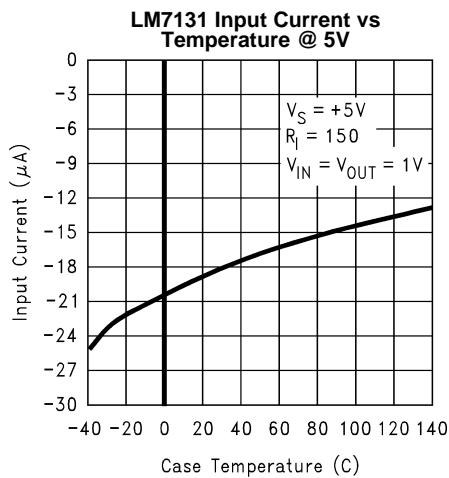

Figure 5.

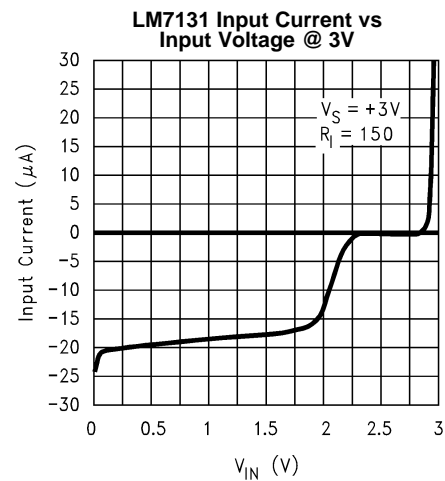

Figure 6.

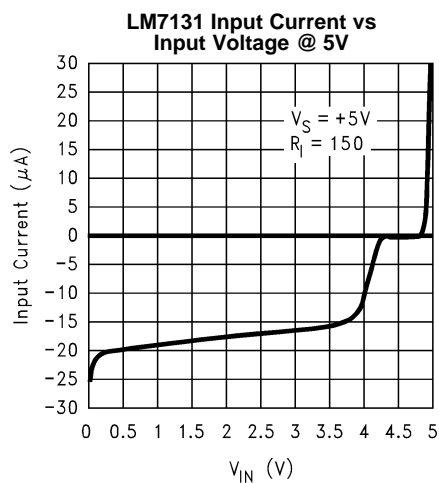

Figure 7.

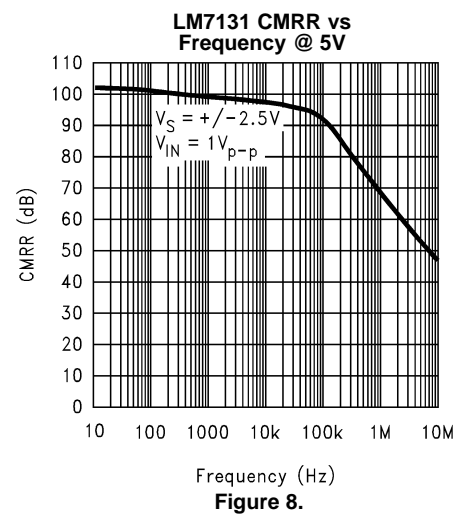

Figure 8.

TYPICAL PERFORMANCE CHARACTERISTICS (continued)

LM7131 Voltage Noise vs Frequency @ 3V

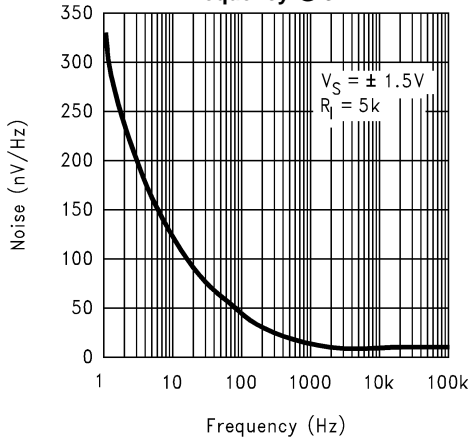

Figure 9.

LM7131 Voltage Noise vs Frequency @ 5V

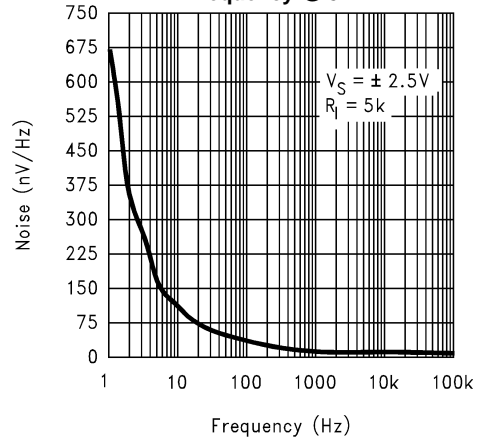

Figure 10.

LM7131 PSRR vs Frequency @ 3V

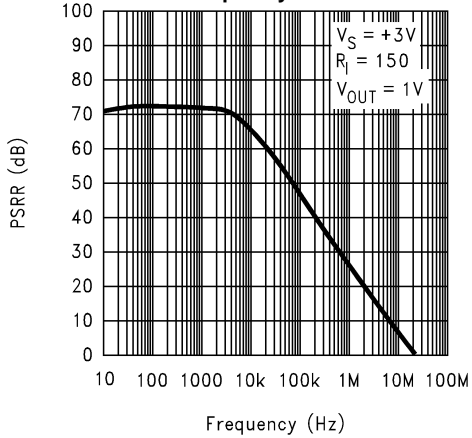

Figure 11.

LM7131 PSRR vs Frequency @ 5V

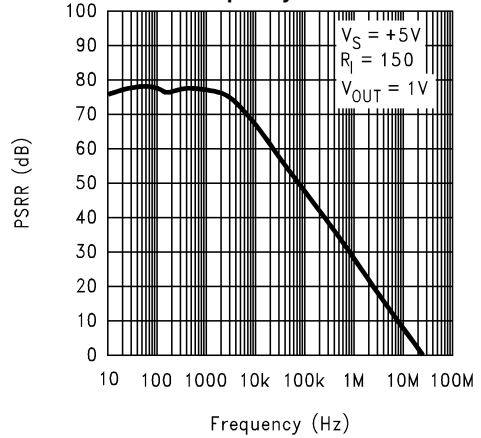

Figure 12.

LM7131 Cable Driver Av = +1 @ +3V

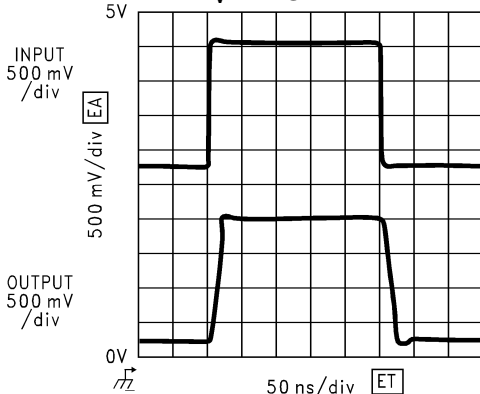

Figure 13.

LM7131 Cable Driver Av = +2 @ +3V

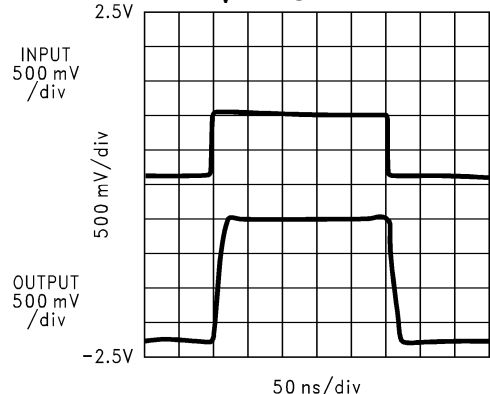

Figure 14.

TYPICAL PERFORMANCE CHARACTERISTICS (continued)

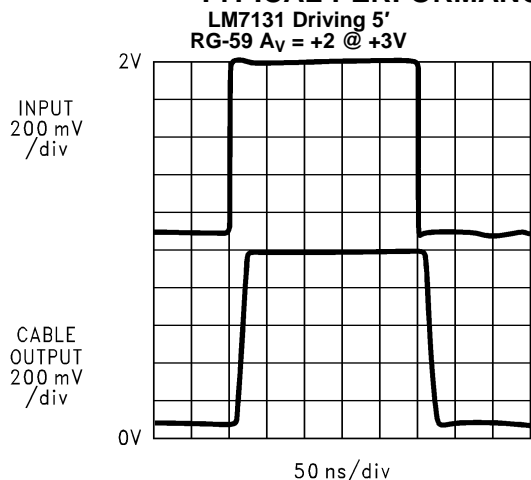

Figure 15.

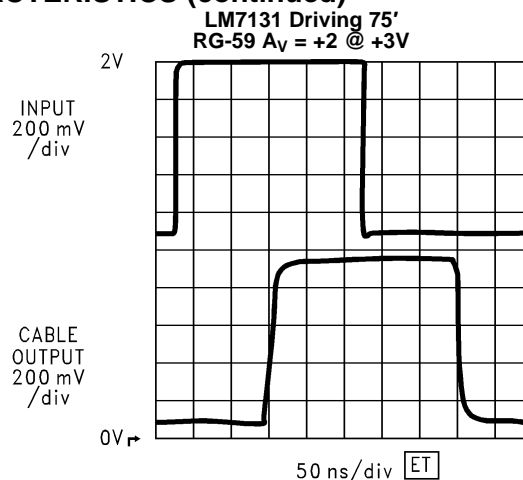

Figure 16.

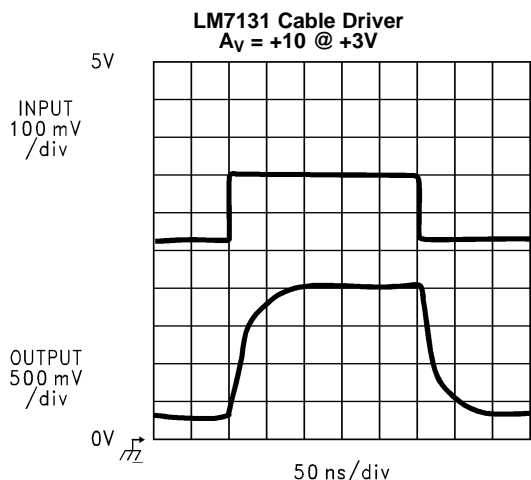

Figure 17.

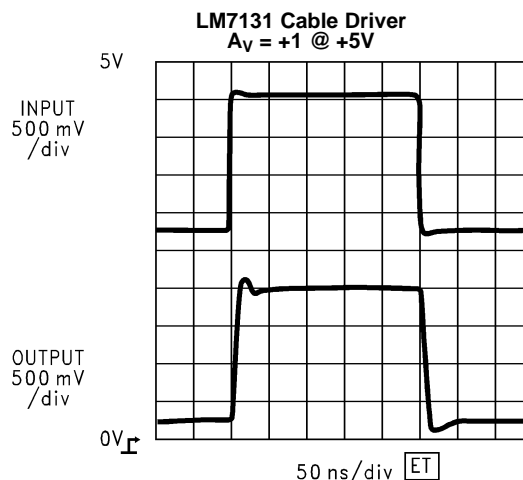

Figure 18.

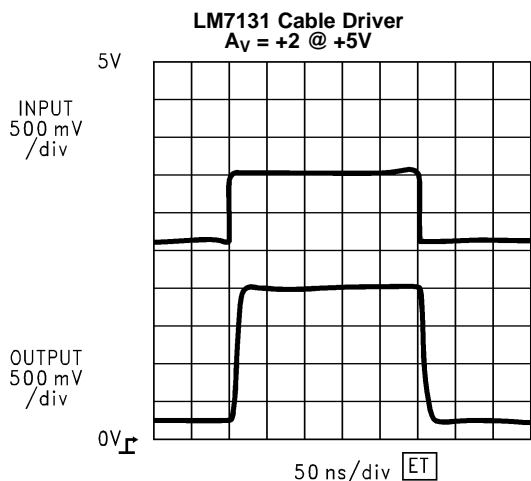

Figure 19.

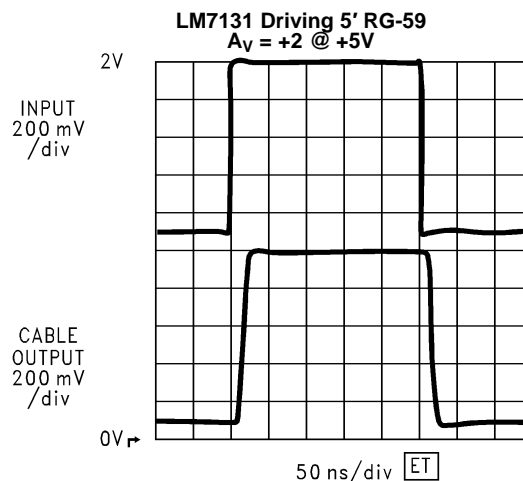

Figure 20.

TYPICAL PERFORMANCE CHARACTERISTICS (continued)

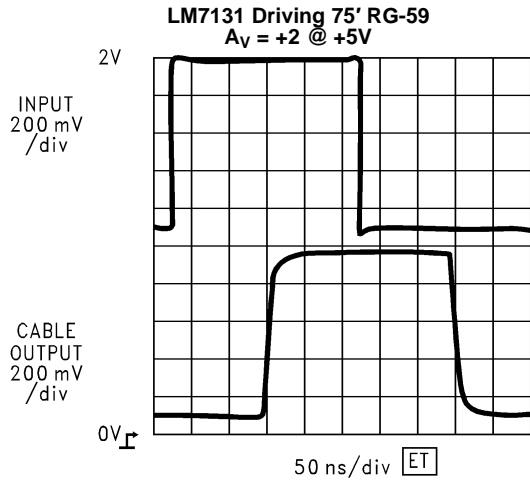

Figure 21.

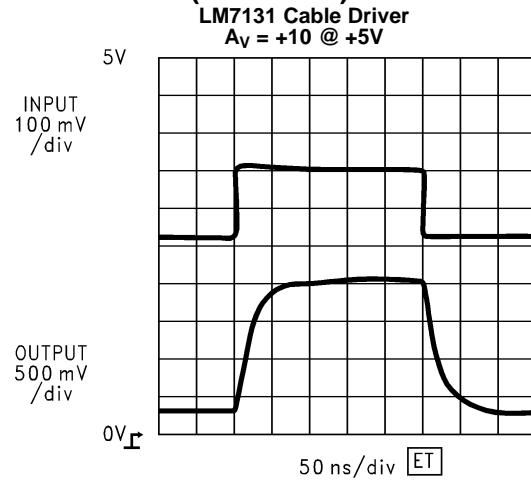

Figure 22.

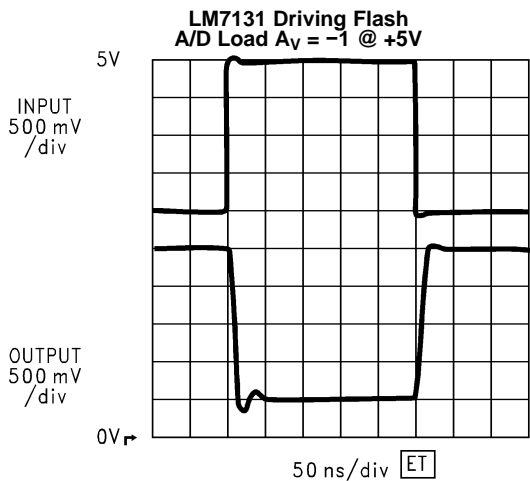

Figure 23.

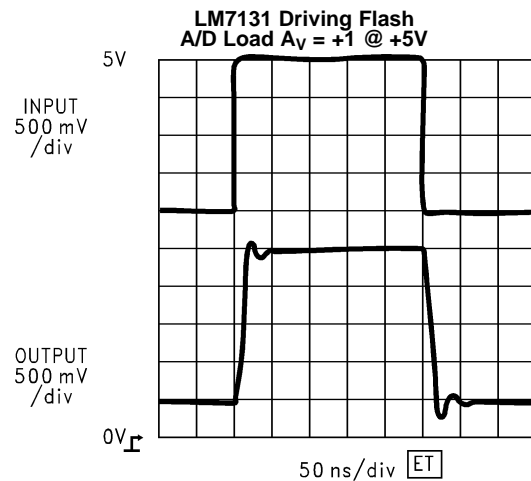

Figure 24.

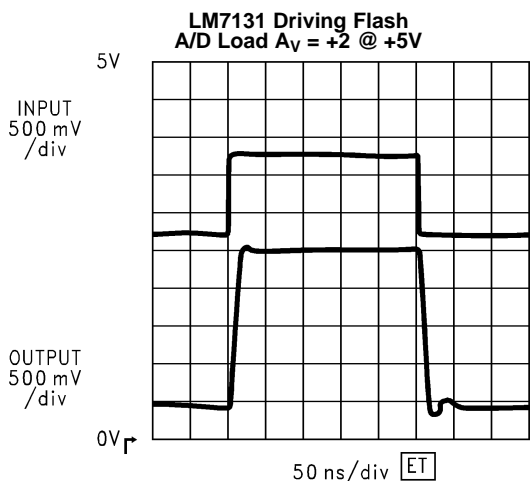

Figure 25.

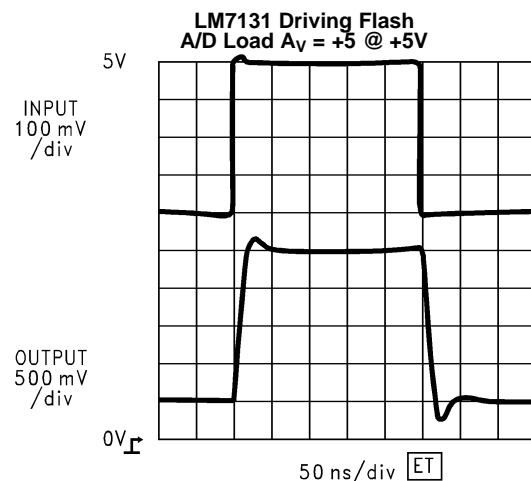

Figure 26.

TYPICAL PERFORMANCE CHARACTERISTICS (continued)

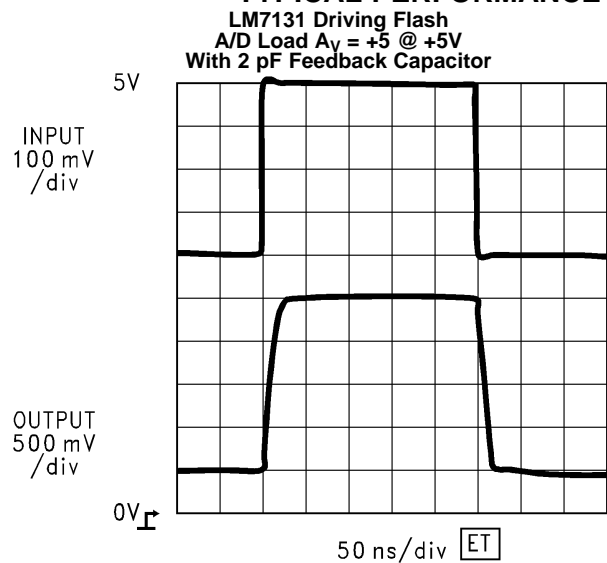

Figure 27.

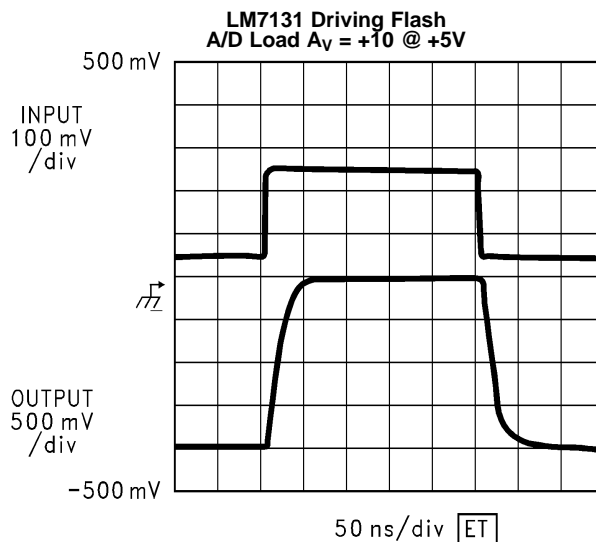

Figure 28.

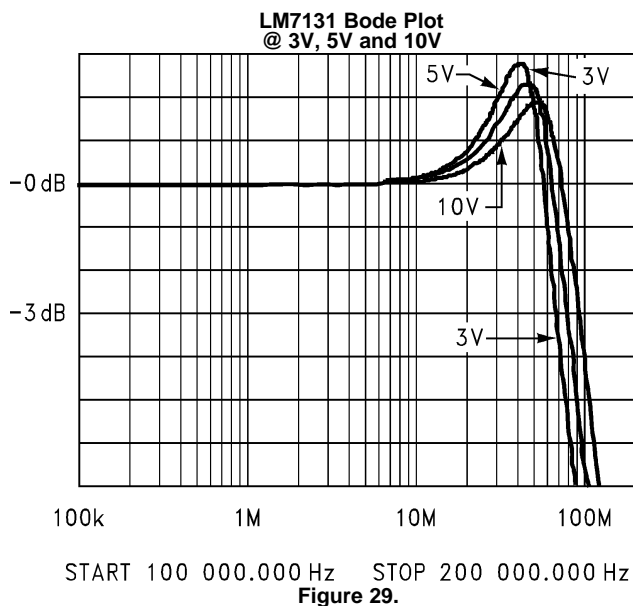

Figure 29.

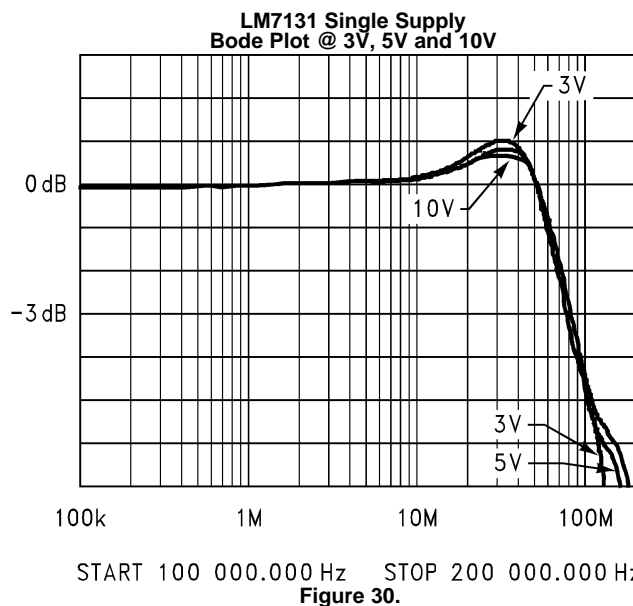

Figure 30.

APPLICATION INFORMATION

General Information

The LM7131 is a high speed complementary bipolar amplifier which provides high performance at single supply voltages. The LM7131 will operate at $\pm 5V$ split supplies, +5V single supplies, and +3V single supplies. It can provide improved performance for $\pm 5V$ designs with an easy transition to +5V single supply. The LM7131 is a voltage feedback amplifier which can be used in most operational amplifier circuits.

The LM7131 is available in two package types: SOIC-8 surface mount package and the SOT23-5 Tiny package for space and weight savings.

The LM7131 has been designed to meet some of the most demanding requirements for single supply amplifiers—driving analog to digital converters and video cable driving. The output stage of the LM7131 has been specially designed for the dynamic load presented by analog to digital converters. The LM7131 is capable of a 4V output range with a +5V single supply. The LM7131's drive capability and good differential gain and phase make quality video possible from a small package with only a +5V supply.

Benefits of the LM7131

The LM7131 can make it possible to amplify high speed signals with a single +5V or +3V supply, saving the cost of split power supplies.

Easy Design Path from $\pm 5V$ to +5V Systems

The SOIC-8 package and similar $\pm 5V$ and single supply specifications means the LM7131 may be able to replace many more expensive or slower op amps, and then be used for an easy transition to 5V single supply systems. This could provide a migration path to lower voltages for the amplifiers in system designs, reducing the effort and expense of testing and re-qualifying different op amps for each new design.

In addition to providing a design migration path, the SOT23-5 Tiny surface mount package can save valuable board space.

Specific Advantages of SOT23-5 (Tiny Package)

The SOT23-5 (Tiny) package can save board space and allow tighter layouts. The low profile can help height limited designs, such as sub-notebook computers, consumer video equipment, personal digital assistants, and some of the thicker PCMCIA cards. The small size can improve signal integrity in noisy environments by placing the amplifier closer to the signal source. The tiny amp can fit into tight spaces and weighs little. This makes it possible to design the LM7131 into places where amplifiers could not previously fit.

The LM7131 can be used to drive coils and transformers referenced to virtual ground, such as magnetic tape heads and disk drive write heads. The small size of the SOT23-5 package can allow it to be placed with a pre-amp inside of some rotating helical scan video head (VCR) assemblies. This avoids long cable runs for low level video signals, and can result in higher signal fidelity.

Additional space savings parts are available in tiny packages from Texas Instruments, including low power amplifiers, precision voltage references, and voltage regulators.

Notes on Performance Curves and Datasheet Limits

NOTE

Important: Performance curves represent an average of parts, and are not limits.

Supply Current vs Supply Voltage

Note that this curve is nearly straight, and rises slowly as the supply voltage increases.

Input Current vs Input Voltage

This curve is relatively flat in the 200 mV to 4V input range, where the LM7131 also has good common mode rejection.

Common Mode Voltage Rejection

Note that there are two parts to the CMRR specification of the datasheet for 3V and 5V. The common mode rejection ratio of the LM7131 has been maximized for signals near ground (typical of the active part of video signals, such as those which meet the RS-170 levels). This can help provide rejection of unwanted noise pick-up by cables when a balanced input is used with good input resistor matching. The mid-level CMRR is similar to that of other single supply op amps.

Bode Plots (Gain vs Frequency for $A_V = +1$)

The gain vs. frequency plots for a non-inverting gain of 1 show the three voltages with the 150Ω load connected in two ways. For the single supply graphs, the load is connected to the most negative rail, which is ground. For the split supply graphs, the load is connected to a voltage halfway between the two supply rails.

Driving Cables

Pulse response curves for driving 75Ω back terminate cables are shown for both 3V and 5V supplies. Note the good pulse fidelity with straight 150 loads, five foot (1.5 meter) and 75 foot (22 meter) cable runs. The bandwidth is reduced when used in a gain of ten ($A_V = +10$). Even in a gain of ten configuration, the output settles to < 1% in about 100 ns, making this useful for amplifying small signals at a sensor or signal source and driving a cable to the main electronics section which may be located away from the signal source. This will reduce noise pickup.

Please refer to [Figure 31](#), [Figure 32](#), [Figure 33](#), [Figure 34](#), and [Figure 35](#) for schematics of test setups for cable driving.

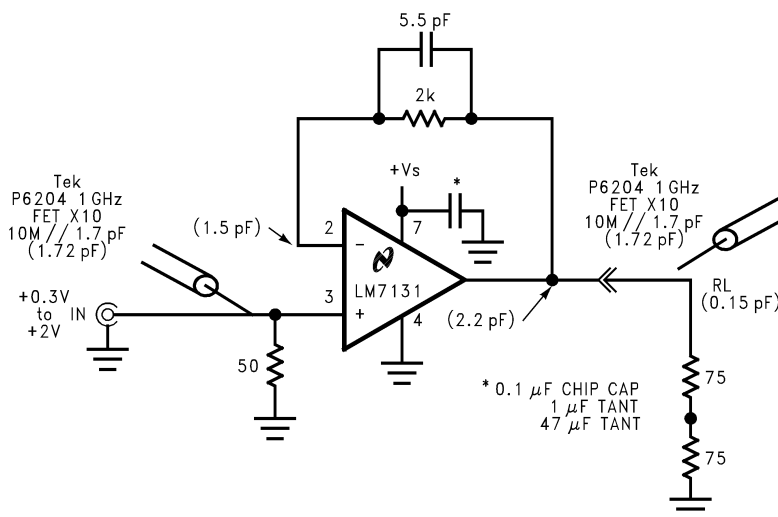

Numbers in parentheses are measured fixture capacitances w/o DUT and load.

Figure 31. Cable Driver $A_V = +1$

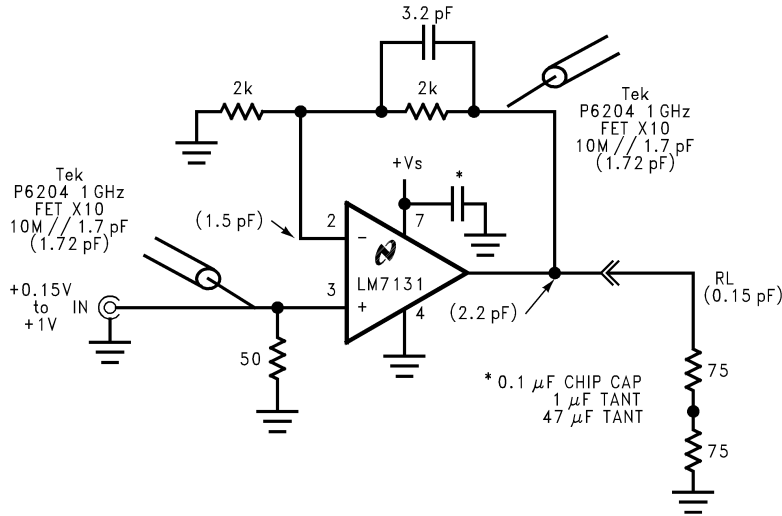

Numbers in parentheses are measured fixture capacitances w/o DUT and load.

Figure 32. Cable Driver $A_V = +2$

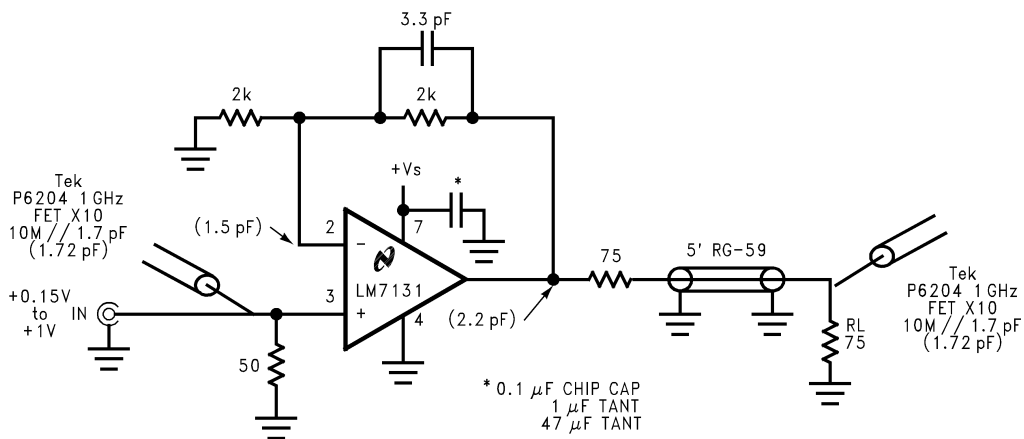

Numbers in parentheses are measured fixture capacitances w/o DUT and load.

Figure 33. Cable Driver 5' RG-59

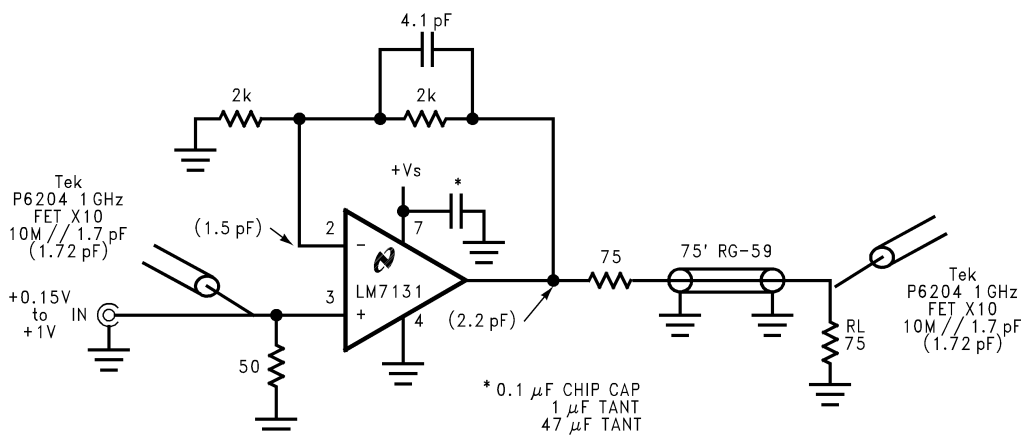

Numbers in parentheses are measured fixture capacitances w/o DUT and load.

Figure 34. Cable Driver 75' RG-59

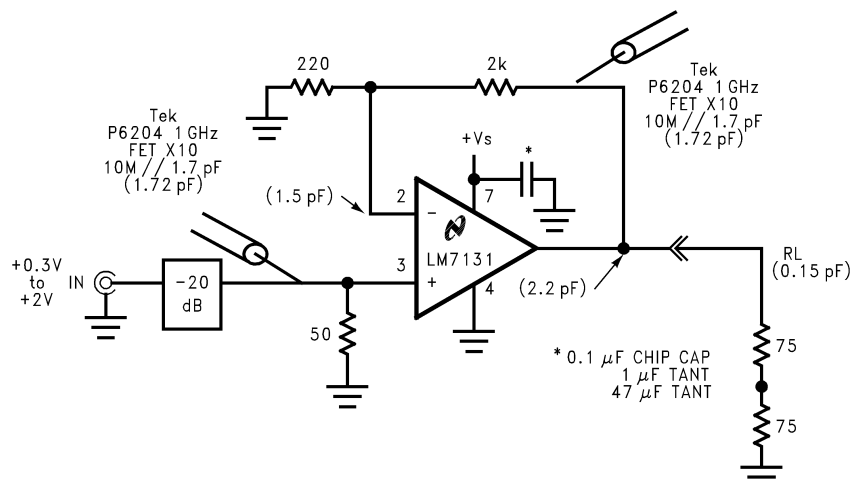

Numbers in parentheses are measured fixture capacitances w/o DUT and load.

Figure 35. Cable Driver Gain of 10 $A_V = +10$

Driving Type 1175 Flash A/D Loads

The circuits in [Figure 36](#) [Figure 37](#) [Figure 38](#) [Figure 39](#) [Figure 40](#) [Figure 41](#) show a LM7131 in a voltage follower configuration driving the passive equivalent of a typical flash A/D input. Note that there is a slight ringing on the output, which can affect accurate analog-to-digital conversion. In these graphs, we have adjusted the ringing to be a little larger than desirable in order to better show the settling time. Most settling times at low gain are about 75 ns to < 1% of final voltage. The ringing can be reduced by adding a low value (approximately 500 Ω) feedback resistor from the output to the inverting input and placing a small (picofarad range) capacitor across the feedback resistor. See [Figure 39](#) and [Figure 40](#) for schematics and respective performance curves for flash A/D driving at $A_V = +5$ with and without a 2 pF feedback capacitor.

See [Feedback Resistor Values](#) and [Feedback Compensation](#). Ringing can also be reduced by placing an isolation resistor between the output and the analog-to-digital converter input—see sections on [Capacitive Load Driving](#) and [Driving Flash A/D Converters \(Video Converters\)](#).

Please refer to [Figure 36](#), [Figure 37](#), [Figure 38](#) [Figure 39](#), [Figure 40](#), and [Figure 41](#) for schematics of test setups for driving flash A/D converters.

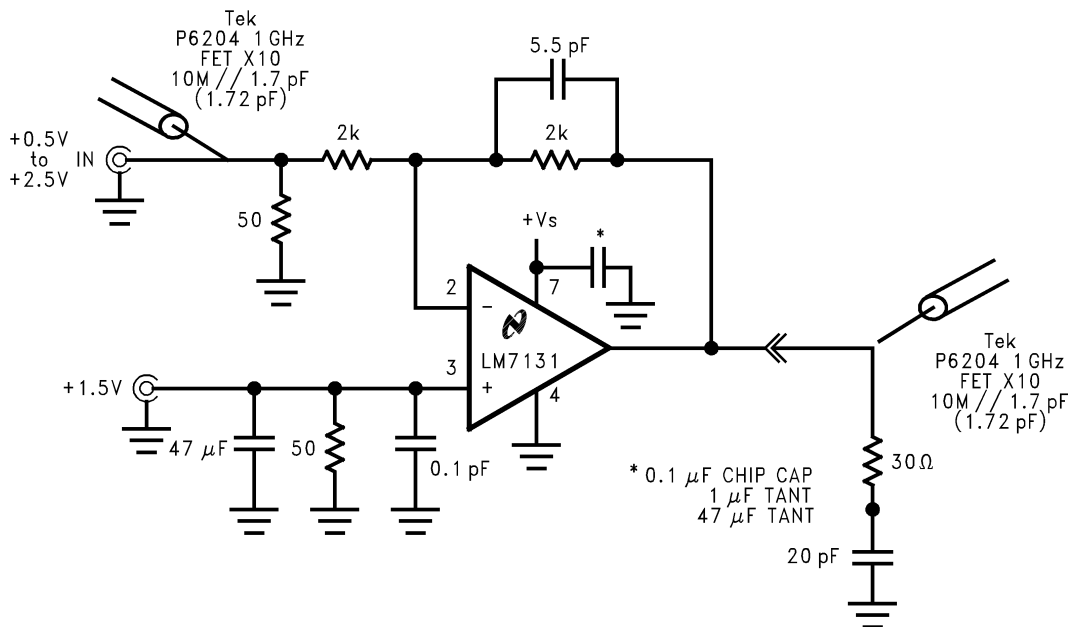

Numbers in parentheses are measured fixture capacitances w/o DUT and load.

Figure 36. Flash A/D $A_V = -1$

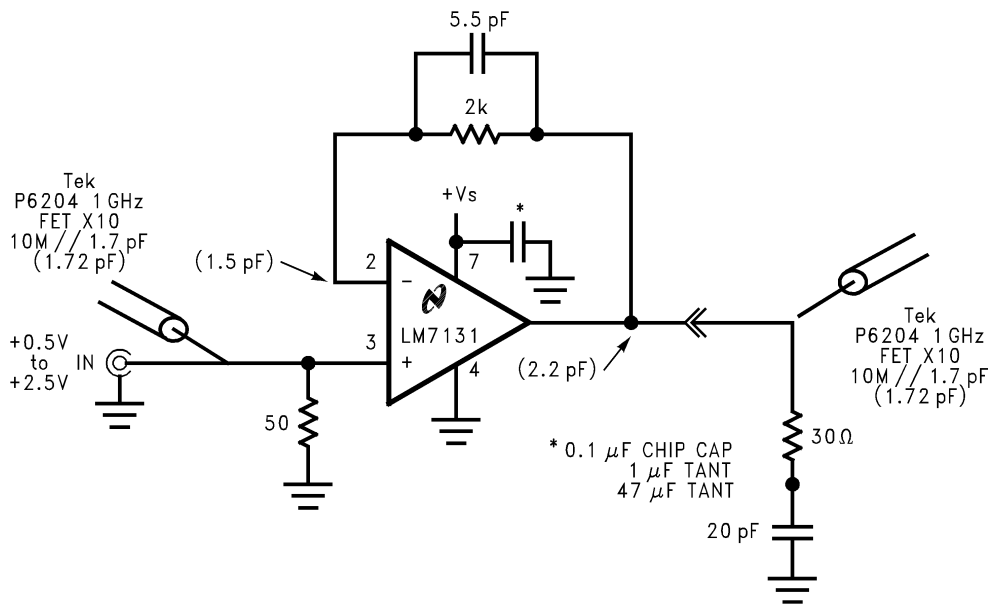

Numbers in parentheses are measured fixture capacitances w/o DUT and load.

Figure 37. Flash A/D $A_V = +1$

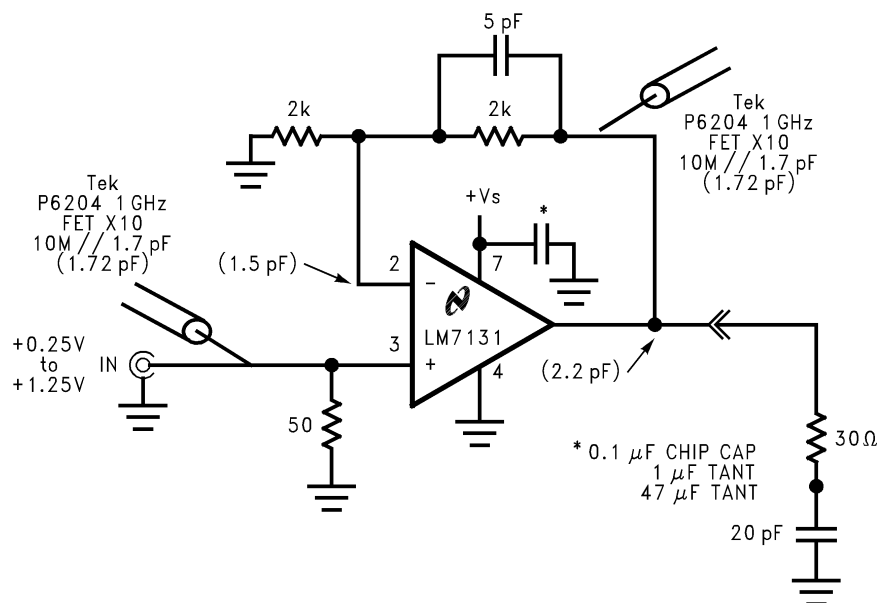

Numbers in parentheses are measured fixture capacitances w/o DUT and load.

Figure 38. Flash A/D $A_V = +2$

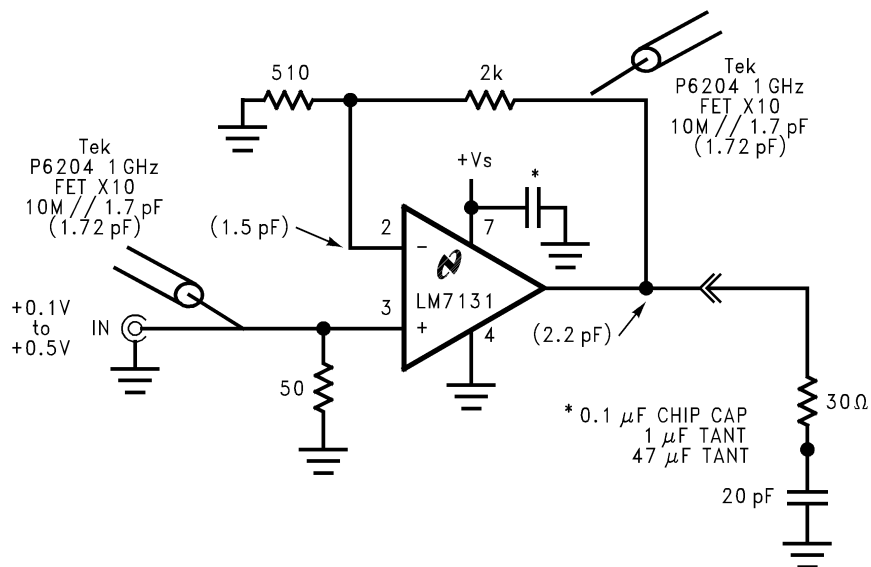

Numbers in parentheses are measured fixture capacitances w/o DUT and load.

Figure 39. Flash A/D $A_V = +5$

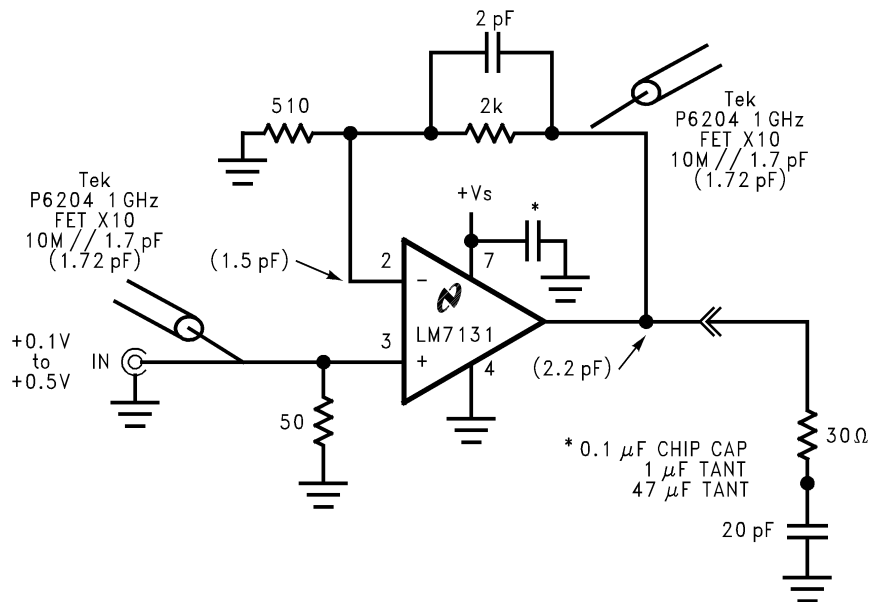

Numbers in parentheses are measured fixture capacitances w/o DUT and load.

Figure 40. Flash A/D $A_V = +5$ with Feedback Capacitor

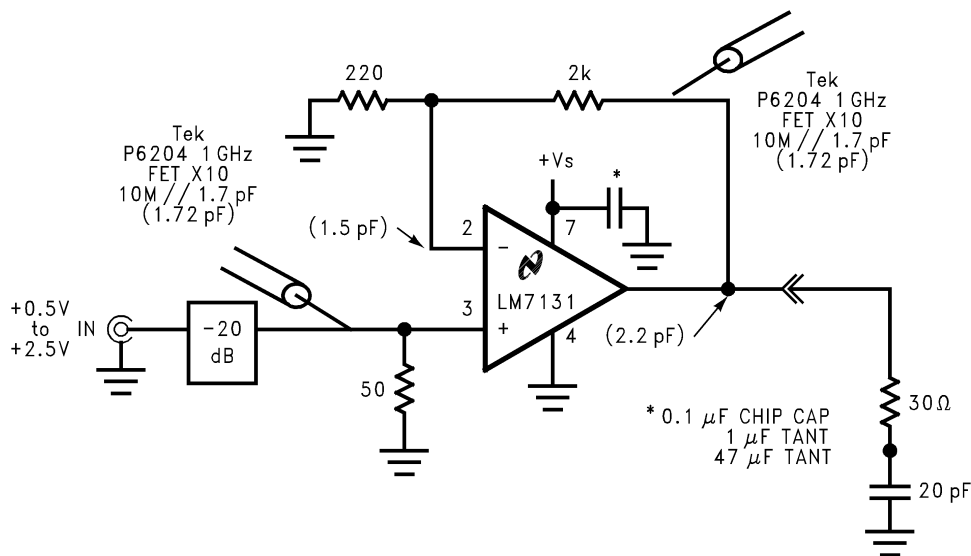

Numbers in parentheses are measured fixture capacitances w/o DUT and load.

Figure 41. Flash A/D $A_V = +10$

Using the LM7131

Limits and Precautions

Supply Voltage

The absolute maximum supply voltage which may be applied to the LM7131 is 12V. Designers should not design for more than 10V nominal, and carefully check supply tolerances under all conditions so that the voltages do not exceed the maximum.

Differential Input Voltage

Differential input voltage is the difference in voltage between the non-inverting (+) input and the inverting input (–) of the op amp. The absolute maximum differential input voltage is $\pm 2\text{V}$ across the inputs. This limit also applies when there is no power supplied to the op amp. This may not be a problem in most conventional op amp designs, however, designers should avoid using the LM7131 as comparator or forcing the inputs to different voltages. In some designs, diode protection may be needed between the inputs. See [Figure 42](#).

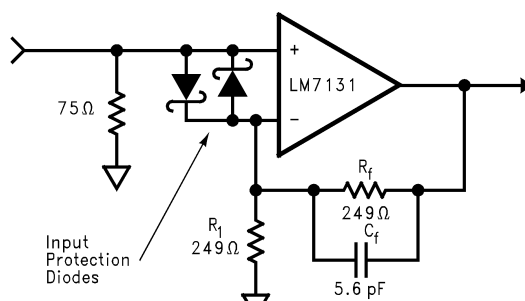

Figure 42. Gain of +2

Output Short Circuits

The LM7131 has output short circuit protection, however, it is not designed to withstand continuous short circuits, very fast high energy transient voltage or current spikes, or shorts to any voltage beyond the power supply rails. Designs should reduce the number and energy level of any possible output shorts, especially when used with $\pm 5\text{V}$ supplies.

A resistor in series with the output, such as the 75Ω resistor used to back terminate 75Ω cables, will reduce the effects of shorts. For outputs which will send signals off the PC board additional protection devices, such as diodes to the power rails, zener-type surge suppressors, and varistors may be useful.

Thermal Management

Note that the SOT23-5 (Tiny) package has less power dissipation capability (325°/W) than the S0-8 package (115°/W). This may cause overheating with ± 5 supplies and heavy loads at high ambient temps. This is less of a problem when using +5V single supplies.

Example:

Driving a 150Ω load to 2.0V at a 40°C (104 °F) ambient temperature. (This is common external maximum temperature for office environments. Temperatures inside equipment may be higher.)

- No load power-
- No load LM7131 supply current - 9.0 mA
- Supply voltage is 5.0V
- No load LM7131 power - 9.0 mA x 5.0V = 45 mW
- Power with load-
- Current out is 2.0V/150 Ω = 13.33 mA
- Voltage drop in LM7131 is 5.0V (supply) – 2.0V (output) = 3.0V
- Power dissipation 13.33 mA x 3.0V = 40 mW
- Total Power = 45 mW + 40 mW = 85 mW = 0.085

- Temperature Rise = $0.085 \text{ W} \times 325^\circ/\text{W} = 27.625$ degrees
- Junction temperature at 40° ambient = $40 + 27.625 = 67.6225^\circ$.
- This device is within the 0° to 70° specification limits.

The $325^\circ/\text{W}$ value is based on still air and the pc board land pattern shown in this datasheet. Actual power dissipation is sensitive to PC board connections and airflow.

SOT23-5 power dissipation may be increased by airflow or by increasing the metal connected to the pads, especially the center pin (pin number 2, V-) on the left side of the SOT23-5. This pin forms the mounting paddle for the die inside the SOT23-5, and can be used to conduct heat away from the die. The land pad for pin 2 can be made larger and/or connected to power planes in a multilayer board.

Additionally, it should be noted that difficulty in meeting performance specifications for the LM7131 is most common at cold temperatures. While excessively high junction temperatures will degrade LM7131 performance, testing has confirmed that most specifications are met at a junction temperature of 85°C .

See "Understanding Integrated Circuit Package Power Capabilities", Application Note AN-336, which may be found in the appendix of the Operational Amplifier Databook.

Layout and Power Supply Bypassing

Since the LM7131 is a high speed (over 50 MHz) device, good high speed circuit layout practices should be followed. This should include the use of ground planes, adequate power supply bypassing, removing metal from around the input pins to reduce capacitance, and careful routing of the output signal lines to keep them away from the input pins.

The power supply pins should be bypassed on both the negative and positive supply inputs with capacitors placed close to the pins. Surface mount capacitors should be used for best performance, and should be placed as close to the pins as possible. It is generally advisable to use two capacitors at each supply voltage pin. A small surface mount capacitor with a value of around 0.01 microfarad (10 nF), usually a ceramic type with good RF performance, should be placed closest to the pin. A larger capacitor, in usually in the range of 1.0 μF to 4.7 μF , should also be placed near the pin. The larger capacitor should be a device with good RF characteristics and low ESR (equivalent series resistance) for best results. Ceramic and tantalum capacitors generally work well as the larger capacitor.

For single supply operation, if continuous low impedance ground planes are available, it may be possible to use bypass capacitors between the +5V supply and ground only, and reduce or eliminate the bypass capacitors on the V- pin.

Capacitive Load Driving

The phase margin of the LM7131 is reduced by driving large capacitive loads. This can result in ringing and slower settling of pulse signals. This ringing can be reduced by placing a small value resistor (typically in the range of 22Ω – 100Ω) between the LM7131 output and the load. This resistor should be placed as close as practical to the LM7131 output. When driving cables, a resistor with the same value as the characteristic impedance of the cable may be used to isolate the cable capacitance from the output. This resistor will reduce reflections on the cable.

Input Current

The LM7131 has typical input bias currents in the 15 μA to 25 μA range. This will not present a problem with the low input impedances frequently used in high frequency and video circuits. For a typical 75Ω input termination, 20 μA of input current will produce a voltage across the termination resistor of only 1.5 mV. An input impedance of 10 k Ω , however, would produce a voltage of 200 mV, which may be large compared to the signal of interest. Using lower input impedances is recommended to reduce this error source.

Feedback Resistor Values and Feedback Compensation

Using large values of feedback resistances (roughly 2k) with low gains (such gains of 2) will result in degraded pulse response and ringing. The large resistance will form a pole with the input capacitance of the inverting input, delaying feedback to the amplifier. This will produce overshoot and ringing. To avoid this, the gain setting resistors should be scaled to lower values (below 1k) At higher gains (> 5) larger values of feedback resistors can be used.

Overshoot and ringing of the LM7131 can be reduced by adding a small compensation capacitor across the feedback resistor. For the LM7131 values in pF to tens of pF range are useful initial values. Too large a value will reduce the circuit bandwidth and degrade pulse response.

Since the small stray capacitance from the circuit layout, other components, and specific circuit bandwidth requirements will vary, it is often useful to select final values based on prototypes which are similar in layout to the production circuit boards.

Reflections

The output slew rate of the LM7131 is fast enough to produce reflected signals in many cables and long circuit traces. For best pulse performance, it may be necessary to terminate cables and long circuit traces with their characteristic impedance to reduce reflected signals.

Reflections should not be confused with overshoot. Reflections will depend on cable length, while overshoot will depend on load and feedback resistance and capacitance. When determining the type of problem, often removing or drastically shortening the cable will reduce or eliminate reflections. Overshoot can exist without a cable attached to the op amp output.

Driving Flash A/D Converters (Video Converters)

The LM7131 has been optimized to drive flash analog to digital converters in a +5V only system. Different flash A/D converters have different voltage input ranges. The LM7131 has enough gain-bandwidth product to amplify standard video level signals to voltages which match the optimum input range of many types of A/D converters.

For example, the popular 1175 type 8-bit flash A/D converter has a preferred input range from 0.6V to 2.6V. If the input signal has an active video range (excluding sync levels) of approximately 700 mV, a circuit like the one in [Figure 43](#) can be used to amplify and drive an A/D. The 10 μ F capacitor blocks the DC components, and allows the + input of the LM7131 to be biased through R clamp so that the minimum output is equal to V_{RB} of the A/D converter. The gain of the circuit is determined as follows:

$$\begin{aligned} \text{Output Signal Range} &= 2.6V (V \text{ top}) - 0.6V (V \text{ bottom}) = 2.0V \\ \text{Gain} &= \text{Output Signal Range} / \text{Input Signal} = 2.857 = 2.00 / 0.700 \\ \text{Gain} &= (R_f / R_i) + 1 = (249\Omega / 133\Omega) + 1 \end{aligned} \quad (1)$$

R isolation and C_f will be determined by the designer based on the A/D input capacitance and the desired pulse response of the system. The nominal values of 33 Ω and 5.6 pF shown in the schematic may be a useful starting point, however, signal levels, A/D converters, and system performance requirements will require modification of these values.

The isolation resistor, R isolation should be placed close to the output of the LM7131, which should be close to the A/D input for best results.

R clamp is connected to a voltage level which will result in the bottom of the video signal matching the V_{rb} level of the A/D converter. This level will need to be set by clamping the black level of the video signal. The clamp voltage will depend on the level and polarity of the video signal. Detecting the sync signal can be done by a circuit such as the LM1881 Video Sync Separator.

NOTE

This is an illustration of a conceptual use of the LM7131, not a complete design. The circuit designer will need to modify this for input protection, sync, and possibly some type of gain control for varying signal levels.

Some A/D converters have wide input ranges where the lower reference level can be adjusted. With these converters, best distortion results are obtained if the lower end of the output range is about 250 mV or more above the V_- input of the LM7131 more. The upper limit can be as high as 4.0V with good results.

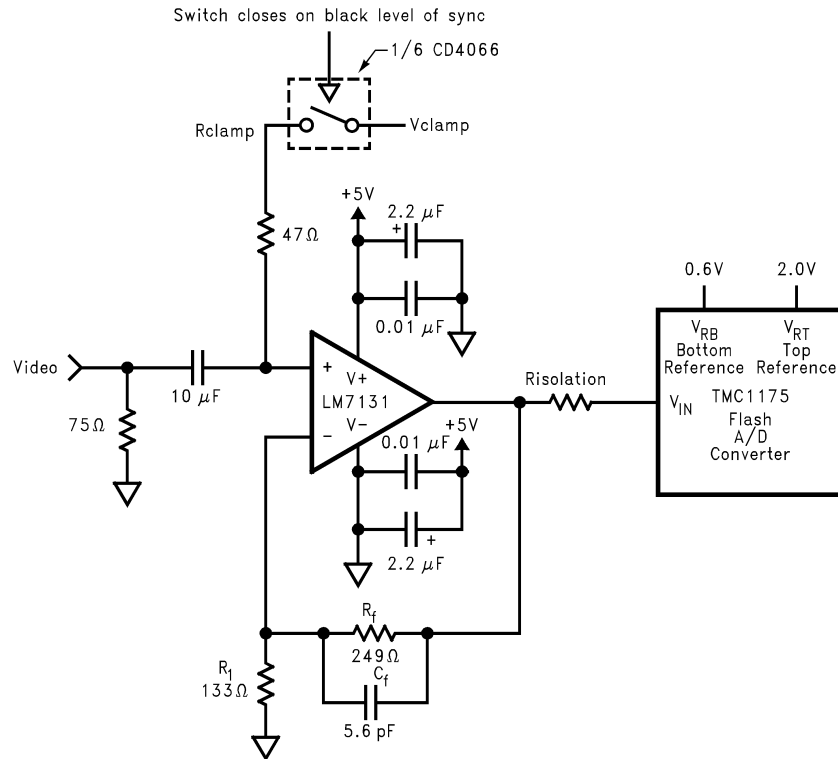

Figure 43. Driving Flash A/D Converter

CCD Amplifiers

The LM7131 has enough gain bandwidth to amplify low level signals from a CCD or similar image sensor and drive a flash analog-to-digital converter with one amplifier stage.

Signals from CCDs, which are used in scanners, copiers, and digital cameras, often have an output signal in the 100 mV–300 mV range. See Figure 44 for a conceptual diagram. With a gain of 6 the output to the flash analog-to-digital converter is 1.8V, matching 90% of the converter's 2V input range. With a –3db bandwidth of 70 MHz for a gain of +1, the bandwidth at a gain of 6 will be 11.6 MHz. This 11.6 MHz bandwidth will result in a time constant of about 13.6 ns. This will allow the output to settle to 7 bits of accuracy within 4.9 time constants, or about 66 ns. Slewing time for a 1.8V step will be about 12 ns. The total slewing and settling time will be about 78 ns of the 150 ns pixel valid time. This will leave about 72 ns total for the flash converter signal acquisition time and tolerance for timing signals.

For scanners and copiers with moving scan bars, the SOT23-5 package is small enough to be placed next to the light sensor. The LM7131 can drive a cable to the main electronics section from the scan bar. This can reduce noise pickup by amplifying the signal before sending on the cable.

A/D Reference Drivers

The LM7131's output and drive capability make it a good choice for driving analog-to-digital references which have suddenly changing loads. The small size of the SOT23-5 package allow the LM7131 to be placed very close to the A/D reference pin, maximizing response. The small size avoids the penalty of increased board space. Often the SOT23-5 package is small enough that it can fit in space used by the large capacitors previously attached to the A/D reference. By acting as a buffer for a reference voltage, noise pickup can be reduced and the accuracy may be increased.

For additional space savings, the LM4040 precision voltage reference and LM385 low current voltage reference are available in a tiny SOT23-3 package.

Video Gain of +2

The design of the LM7131 has been optimized for gain of +2 video applications. Typical values for differential gain and phase are 0.25% differential gain and 0.75 degree differential phase. See [Figure 42](#).

Improving Video Performance

Differential gain and phase performance can be improved by keeping the active video portion of the signal above 300 mV. The sync signal can go below 300 mV without affecting the video quality. If it is possible to AC couple the signal and shift the output voltage slightly higher, much better video performance is possible. For a +5V single supply, an output range between 2.0V and 3.0V can have a differential gain of 0.07% and differential phase of 0.3 degree when driving a 150Ω load. For a +3V single supply, the output should be between 1.0V and 2.0V.

Cable Driving with +5V Supplies

The LM7131 can easily drive a back-terminated 75Ω video cable (150Ω load) when powered by a +5V supply. See [Figure 32](#), [Figure 33](#), and [Figure 34](#). This makes it a good choice for video output for portable equipment, personal digital devices, and desktop video applications.

The LM7131 can also supply +2.00V to a 50Ω load to ground, making it useful as driver in 50Ω systems such as portable test equipment.

Cable Driving with +3V Supplies

The LM7131 can drive 150Ω to 2.00V when supplied by a 3V supply. This 3V performance means that the LM7131 is useful in battery powered video applications, such as camcorders, portable video mixers, still video cameras, and portable scanners.

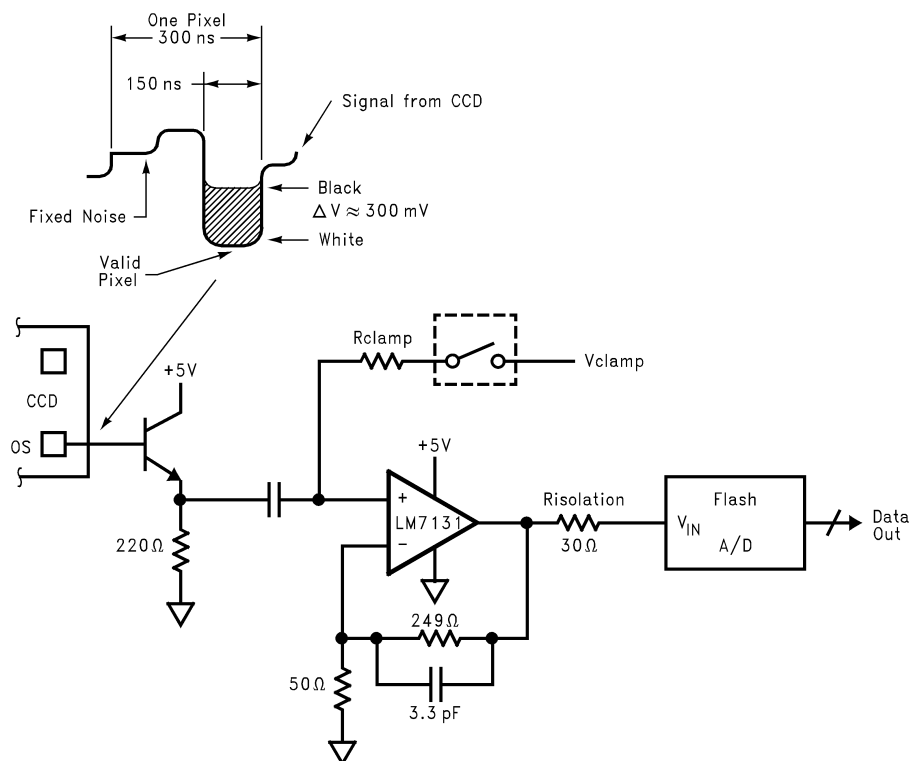

Figure 44. CCD Amplifier

Audio and High Frequency Signal Processing

The LM7131 is useful for high fidelity audio and signal processing. A typical LM7131 is capable of driving 2V across 150Ω (referenced to ground) at less than 0.1% distortion at 4 MHz when powered by a single 5V supply.

Use with 2.5V Virtual Ground Systems with +5V Single Supply Power

Many analog systems which must work on a single +5V supply use a “virtual ground” - a reference voltage for the signal processing which is usually between +5V and 0V. This virtual ground is usually halfway between the top and bottom supply rails. This is usually +2.5V for +5V systems and +1.5V for +3V systems.

The LM7131 can be used in single supply/virtual ground systems driving loads referenced to 2.5V. The output swing specifications in the data sheet show the tested voltage limits for driving a 150Ω load to a virtual ground supply for +3V and +5V. A look at the output swing specifications shows that for heavy loads like 150 ohms, the output will swing as close as one diode drop (roughly, 0.7V) to the supply rail. This leaves a relatively wide range for +5V systems and a somewhat narrow range for +3V systems. One way to increase this output range is to have the output load referenced to ground—this will allow the output to swing lower. Another is to use higher load impedances. The output swing specifications show typical numbers for swing with loads of 600Ω to ground. Note that these typical numbers are similar to those for a 150Ω load. These typical numbers are an indication of the maximum DC performance of the LM7131.

The sinking output of the LM7131 is somewhat lower than the amplifier's sourcing capability. This means that the LM7131 will not drive as much current into a load tied to 2.5 V as it will drive into a load tied to 0V.

Good AC performance will require keeping the output further away from the supply rails. For a +5V supply and relatively high impedance load (analog-to-digital converter input) the following are suggested as an initial starting range for achieving high (> 60 dB) AC accuracy

Upper output level—

Approximately 0.8V to 1V below the positive (V+) rail.

Lower output level—

Approximately 200 mV–300 mV above the negative rail.

The LM7131 very useful in virtual ground systems as an output device for output loads which are referenced to 0V or the lower rail. It is also useful as a driver for capacitive loads, such as sample and hold circuits, and audio analog to digital converters. If fast amplifiers with rail-to-rail output ranges are needed, please see the Texas Instruments LM6142 datasheet.

D/A Output Amplifier

The LM7131 can be used as an output amplifier for fast digital-to-analog converters. When using the LM7131 with converters with an output voltage range which may exceed the differential input voltage limit of ±2V, it may be necessary to add protection diodes to the inputs. See [Figure 45](#). For high speed applications, it may be useful to consider low capacitance schottky diodes. Additional feedback capacitance may be needed to control ringing due to the additional input capacitance from the D/A and protection diodes. When used with current output D/As, the input bias currents may produce a DC offset in the output. This offset may be canceled by a resistor between the positive input and ground.

SPICE Macromodel

A SPICE macromodel of the LM7131 and many other Texas Instruments op amps is available at no charge from your Texas Instruments representative.

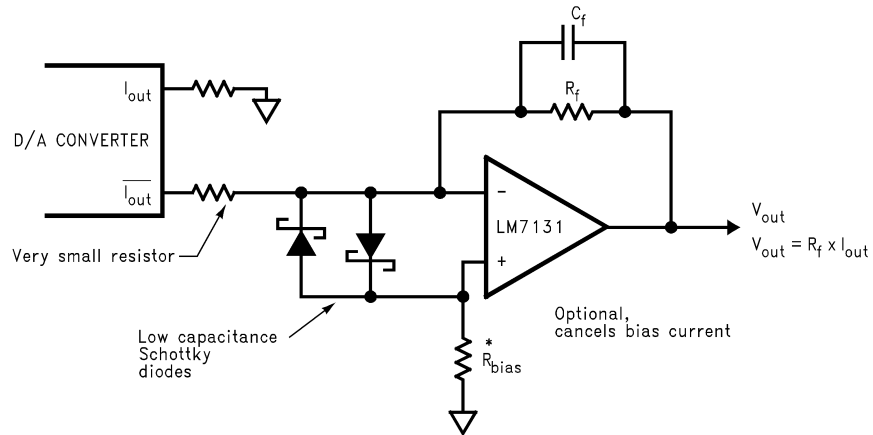

Figure 45. D/A Output Amplifier

REVISION HISTORY

Changes from Revision B (April 2013) to Revision C	Page
• Changed layout of National Data Sheet to TI format	26

IMPORTANT NOTICE

Texas Instruments Incorporated and its subsidiaries (TI) reserve the right to make corrections, enhancements, improvements and other changes to its semiconductor products and services per JESD46, latest issue, and to discontinue any product or service per JESD48, latest issue. Buyers should obtain the latest relevant information before placing orders and should verify that such information is current and complete. All semiconductor products (also referred to herein as "components") are sold subject to TI's terms and conditions of sale supplied at the time of order acknowledgment.

TI warrants performance of its components to the specifications applicable at the time of sale, in accordance with the warranty in TI's terms and conditions of sale of semiconductor products. Testing and other quality control techniques are used to the extent TI deems necessary to support this warranty. Except where mandated by applicable law, testing of all parameters of each component is not necessarily performed.

TI assumes no liability for applications assistance or the design of Buyers' products. Buyers are responsible for their products and applications using TI components. To minimize the risks associated with Buyers' products and applications, Buyers should provide adequate design and operating safeguards.

TI does not warrant or represent that any license, either express or implied, is granted under any patent right, copyright, mask work right, or other intellectual property right relating to any combination, machine, or process in which TI components or services are used. Information published by TI regarding third-party products or services does not constitute a license to use such products or services or a warranty or endorsement thereof. Use of such information may require a license from a third party under the patents or other intellectual property of the third party, or a license from TI under the patents or other intellectual property of TI.

Reproduction of significant portions of TI information in TI data books or data sheets is permissible only if reproduction is without alteration and is accompanied by all associated warranties, conditions, limitations, and notices. TI is not responsible or liable for such altered documentation. Information of third parties may be subject to additional restrictions.

Resale of TI components or services with statements different from or beyond the parameters stated by TI for that component or service voids all express and any implied warranties for the associated TI component or service and is an unfair and deceptive business practice. TI is not responsible or liable for any such statements.

Buyer acknowledges and agrees that it is solely responsible for compliance with all legal, regulatory and safety-related requirements concerning its products, and any use of TI components in its applications, notwithstanding any applications-related information or support that may be provided by TI. Buyer represents and agrees that it has all the necessary expertise to create and implement safeguards which anticipate dangerous consequences of failures, monitor failures and their consequences, lessen the likelihood of failures that might cause harm and take appropriate remedial actions. Buyer will fully indemnify TI and its representatives against any damages arising out of the use of any TI components in safety-critical applications.

In some cases, TI components may be promoted specifically to facilitate safety-related applications. With such components, TI's goal is to help enable customers to design and create their own end-product solutions that meet applicable functional safety standards and requirements. Nonetheless, such components are subject to these terms.

No TI components are authorized for use in FDA Class III (or similar life-critical medical equipment) unless authorized officers of the parties have executed a special agreement specifically governing such use.

Only those TI components which TI has specifically designated as military grade or "enhanced plastic" are designed and intended for use in military/aerospace applications or environments. Buyer acknowledges and agrees that any military or aerospace use of TI components which have **not** been so designated is solely at the Buyer's risk, and that Buyer is solely responsible for compliance with all legal and regulatory requirements in connection with such use.

TI has specifically designated certain components as meeting ISO/TS16949 requirements, mainly for automotive use. In any case of use of non-designated products, TI will not be responsible for any failure to meet ISO/TS16949.

Products

Audio	www.ti.com/audio
Amplifiers	amplifier.ti.com
Data Converters	dataconverter.ti.com
DLP® Products	www.dlp.com
DSP	dsp.ti.com
Clocks and Timers	www.ti.com/clocks
Interface	interface.ti.com
Logic	logic.ti.com
Power Mgmt	power.ti.com
Microcontrollers	microcontroller.ti.com
RFID	www.ti-rfid.com
OMAP Applications Processors	www.ti.com/omap
Wireless Connectivity	www.ti.com/wirelessconnectivity

Applications

Automotive and Transportation	www.ti.com/automotive
Communications and Telecom	www.ti.com/communications
Computers and Peripherals	www.ti.com/computers
Consumer Electronics	www.ti.com/consumer-apps
Energy and Lighting	www.ti.com/energy
Industrial	www.ti.com/industrial
Medical	www.ti.com/medical
Security	www.ti.com/security
Space, Avionics and Defense	www.ti.com/space-avionics-defense
Video and Imaging	www.ti.com/video

TI E2E Community

e2e.ti.com