

78SR Series

3.3V/5V/12V Outputs High-Efficiency Switching Regulators with LM78XX Pinouts

NEW
low-profile package

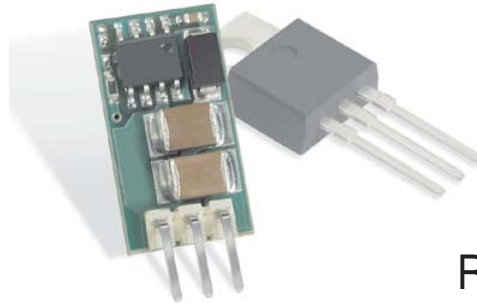

Order online at www.datel.com

Features

- 3.3V/0.5A, 5V/0.5A or 12V/0.4A outputs; Pin and size-compatible with LM7805 & LM7812 regulators
- Up to 95% efficiency – no heat sinks or thermal derating required!
- Two SIP-packages fit existing TO-220 footprints:
Vertical-pin models occupy less than 0.1 square in.
Optional horizontal pins provide 0.350 in. installed height
- +7.5-36Vdc operating input range; Low 3mA quiescent current
- Built-in filter capacitors – no external components required
- -40 to +70°C operation at full load; Short-circuit protection
- Excellent load ($\pm 0.2\%$) and line ($\pm 0.3\%$) regulation
- Ideal for powering instrumentation from 9V/12V/24V/28V supplies or batteries
- Can be used with unregulated dc supplies

DATEL's 7805SR (5V output), 7812SR (12V output) and 7803SR (3.3V output) step-down switching regulators are modern drop-in replacements for older, inefficient, LM7805 and LM7812 linear regulators. The 78XXSR's are pin- and size-compatible with industry-standard TO-220 SIP packages. A 260kHz switching frequency provides for efficiencies as high as 95%. Full-load (up to 0.5A) operation from 9V, 12V, 24V, or 36V supplies at ambient temperatures up to +70°C requires no heat sinks, no temperature derating, no forced-air cooling, and no external capacitors.

78SR switching regulators provide many significant improvements over their linear counterparts: lower quiescent current (3mA vs. 5 mA), higher input voltage (40V vs. 32V), and better output accuracy ($\pm 1.5\%$ vs. $\pm 5\%$). All these features combine to make 78SR regulators ideal for new or existing LM7805 & LM7812 applications requiring full-load operation at elevated voltages.

Technical Notes

- 1. Input/Output (I/O) Filtering:** As shown in the noise and ripple graphs, 78SR switching regulators exhibit excellent low-noise performance with no external I/O capacitors. However, if additional noise reduction is required, be sure to use low-ESR capacitors that are rated for continuous operation (with an additional 20% safety margin) at the highest system voltages and temperatures. Adding external output capacitors will also improve the unit's load-transient response.
- 2. Input Fusing:** 78SR switching regulators are not internally fused. If fusing their input and/or output terminals is required, use the data shown in the Efficiency Curves as a guide to selecting an appropriate slow-blow fuse.
- 3. Input-Output Isolation:** 78SR regulators' internal input and output circuits share a common connection (GND, pin 2); there is no electrical isolation between the INPUT (pin 1) and OUTPUT (pin 3) terminals.
- 4. Overvoltage Protection:** 78SR switching regulators do not provide input or output overvoltage protection. In the extremely rare situation in which a catastrophic failure occurs, the output voltage may rise to excessively high levels. If your load must be protected against all possible overvoltage situations, external voltage-limiting circuitry must be provided.
- 5. Operation at 40Vdc:** Operating with inputs up to 40Vdc is permissible if, for inputs between 36 and 40Vdc, the maximum load current is reduced to 0.35A for 7805SR and 7803SR, and to 0.3A for 7812SR.

Under no circumstances should the input voltage be allowed to exceed 45Vdc.

- 6. Soldering & Handling Precautions:** All units are designed to be hand soldered to pc-boards using no-clean solders (+260°C, 5 seconds max.). Water-soluble solders can also be used, but the units must be washed and dried using processes appropriate to the type of solder employed. See the Mechanical Specifications section for pin 1 orientation and recommended plated-through hole dimensions.

While 78SR regulators easily withstand a 2kV ESD discharge to any terminal (using human body model), they should always be treated as ESD sensitive devices.

- 7. Horizontal-Pin Models (78XXSRH):** 78XXSRH switching regulators are pin-compatible replacements for TO-220 style LM78XX linear regulators that are installed with their metal tabs lying flat on the surface of the pc-board. However, because the surface of inductor L1 on 78XXSRH models is electrically conductive, it must not be allowed to come in contact with any exposed pc-board traces, other than power ground (GND).

While the 2-mil-thick (0.05mm) polyester label attached to L1 provides some degree of electrical insulation (only if L1 sits perfectly flat on the pc-board), it is recommended that a 0.020" (0.5mm) clearance be maintained between L1 and all exposed pc-board traces.

Performance/Functional Specifications

Typical at $T_A = +25^\circ\text{C}$

Input/Output			
Models	7803SR	7805SR	7812SR
Output Voltage	+3.3Vdc	+5.0Vdc	+12.0Vdc
Rated Output Current	0.5A	0.5A	0.4A
Output Voltage Accuracy	$\pm 2\%$	$\pm 1.5\%$	$\pm 2\%$
Input Voltage Range ①	+7.5-36Vdc	+7.5-36Vdc	+15-36Vdc
Line Regulation (100% load)	$\pm 0.3\%$	$\pm 0.3\%$	$\pm 0.3\%$
Load Regulation (0-100% load)	$\pm 0.2\%$	$\pm 0.2\%$	$\pm 0.2\%$
Quiescent Current	3mA typ., 5mA max.		
Input Current	See Performance Curves		
Efficiency	See Performance Curves		
Transient Response	See Performance Curves		
Input & Output Noise	See Performance Curves		
Short Circuit Protection ②	Continuous		
Isolation	None		
Overvoltage Protection	None		
Undervoltage Protection	None		

Environmental

Models	7803SR	7805SR	7812SR
Operating Temperature	-40 to +70°C		
Storage Temperature	-40 to +85°C		
Cooling	Free Air Convection		
Humidity (Non-condensing)	0 to 85%		
Physical			
Mechanical	See Mechanical Specifications		
Package	Open-frame SIP		
Pins	0.025" (0.64mm) square, tin-plated bronze		
Weight	0.08 ounces (2.2g)		
Pin Soldering	+260°C for 5 seconds		

① See Technical Note 5.

② While these regulators can withstand a continuous short-circuit across their output terminals, they will experience a significant temperature rise. Extended short-circuit operation will adversely affect the unit's reliability.

Typical Performance Curves $T_A = +25^\circ\text{C}$, V_{IN} as indicated

Noise and Ripple - 10% and 100% Load, 20MHz Bandwidth

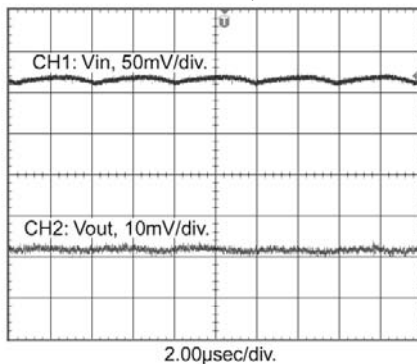
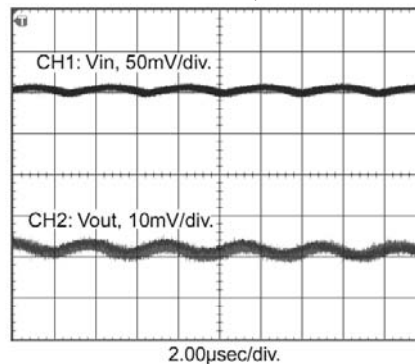
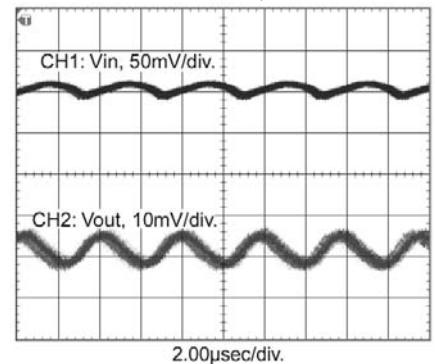
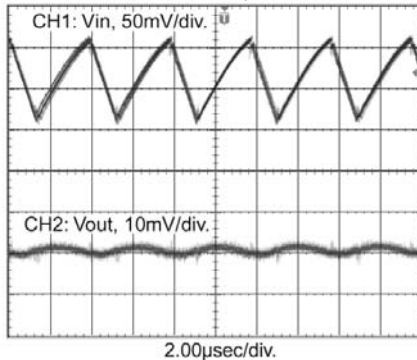
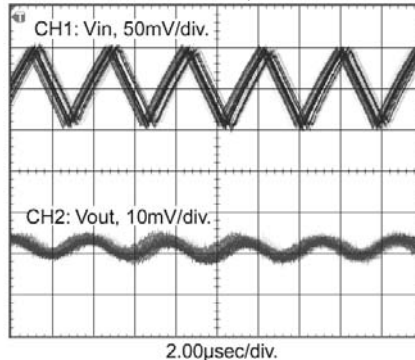
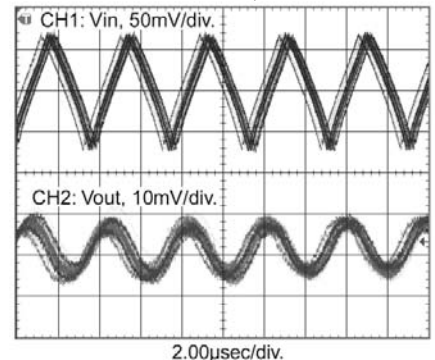
7803SR $V_{in} = 12\text{V}$, $I_{LOAD} = 50\text{mA}$ 7805SR $V_{in} = 12\text{V}$, $I_{LOAD} = 50\text{mA}$ 7812SR $V_{in} = 24\text{V}$, $I_{LOAD} = 40\text{mA}$ 7803SR $V_{in} = 12\text{V}$, $I_{LOAD} = 500\text{mA}$ 7805SR $V_{in} = 12\text{V}$, $I_{LOAD} = 500\text{mA}$ 7812SR $V_{in} = 24\text{V}$, $I_{LOAD} = 400\text{mA}$ 

Transient Response - 90% Load Step

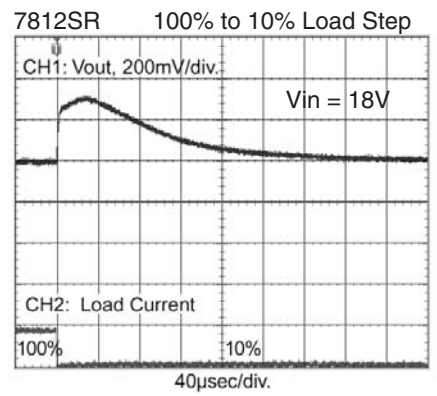
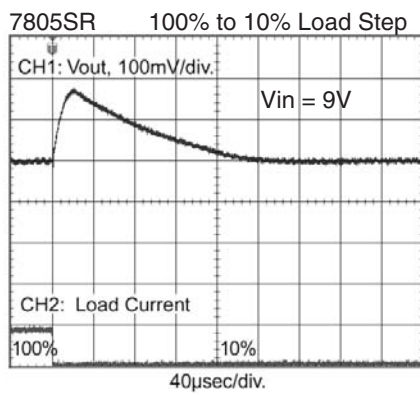
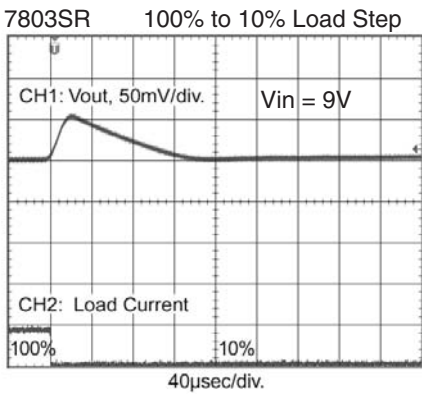
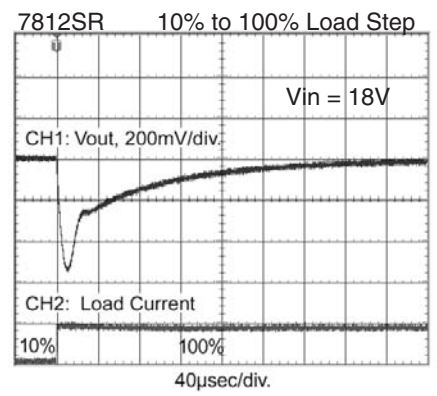
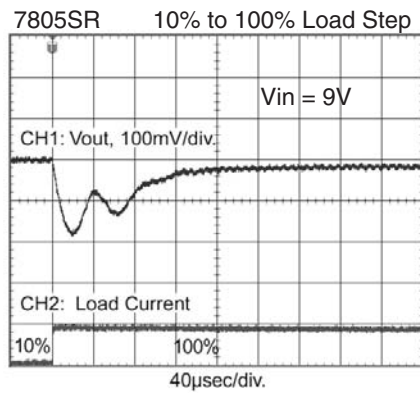
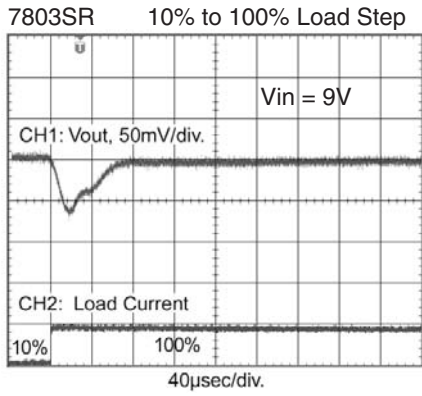

7803SR Efficiency

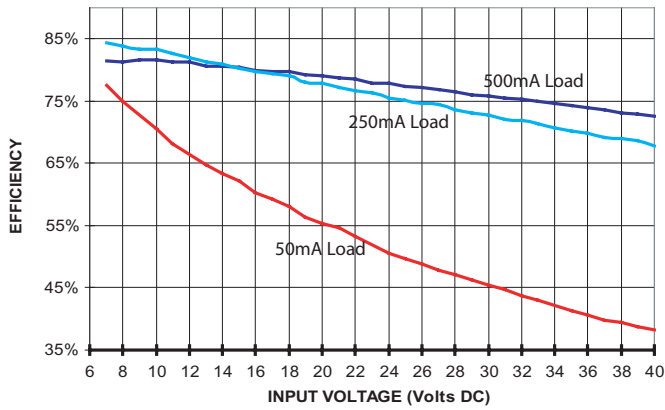

7805SR Efficiency

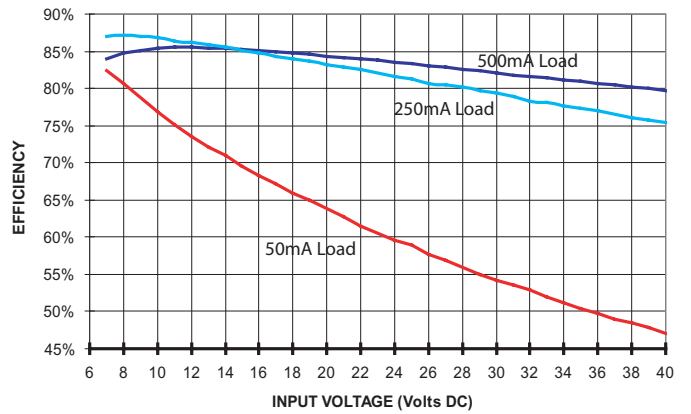

7803SR Input Current

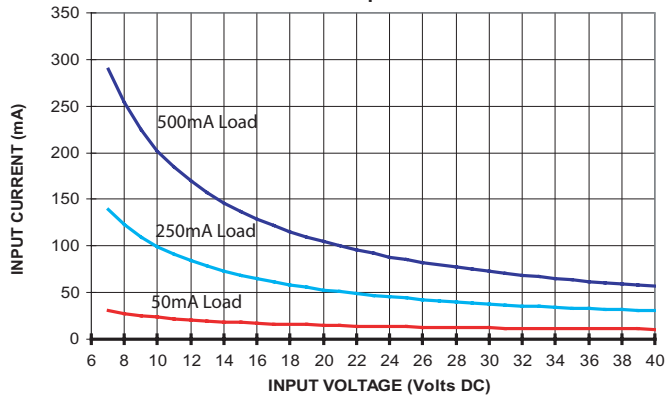

7805SR Input Current

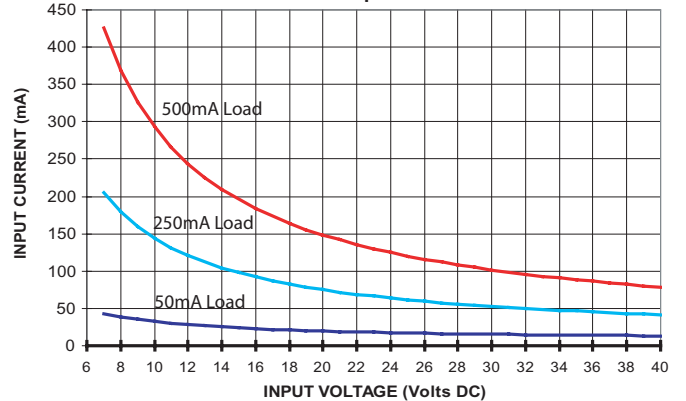

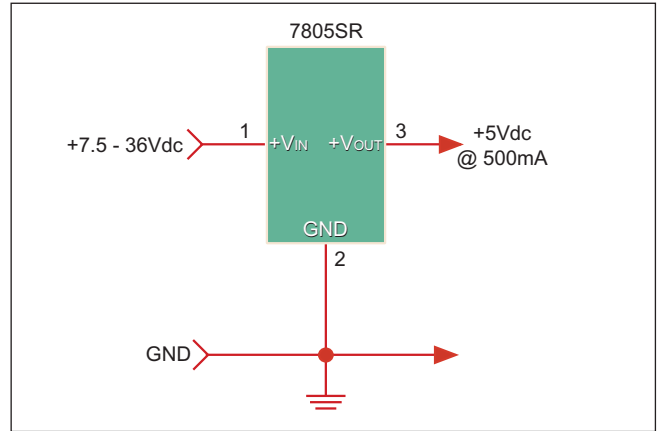
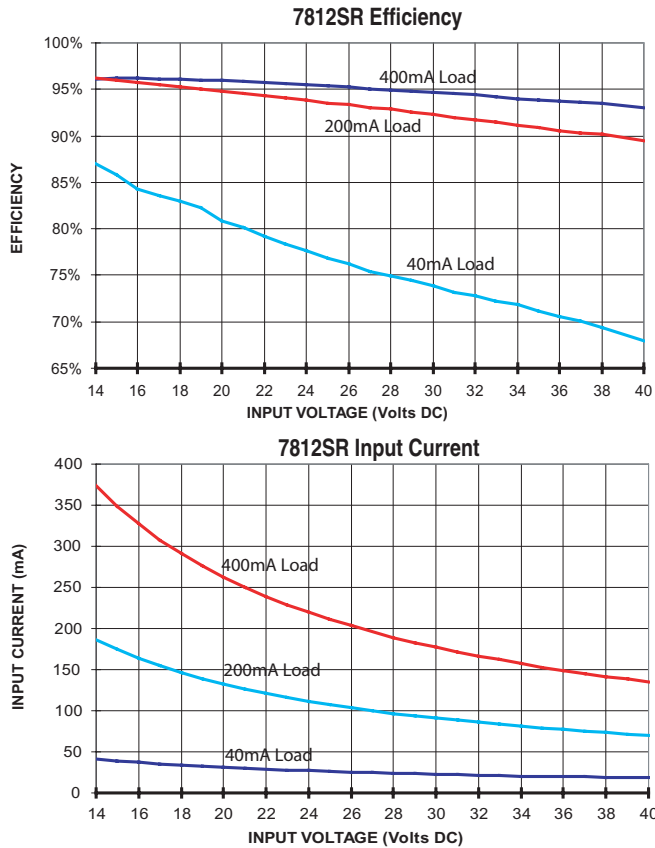

Figure 1. Typical Connections

Ordering Information

DATEL Part No.	Output Voltage	Output Current	Input Voltage
Standard Pin Package			
7803SR	+3.3Vdc	0.5A	+7.5-36Vdc
7805SR	+5.0Vdc	0.5A	+7.5-36Vdc
7812SR	+12.0Vdc	0.4A	+15-36Vdc
Horizontal Pin Package			
7803SRH	+3.3Vdc	0.5A	+7.5-36Vdc
7805SRH	+5.0Vdc	0.5A	+7.5-36Vdc
7812SRH	+12.0Vdc	0.4A	+15-36Vdc

Mechanical Specifications

MECHANICAL DIMENSIONS: Inches (mm)
 TOLERANCES: 2 PL DEC ±0.02 (±0.51)
 3 PL DEC ±0.010 (±0.254)

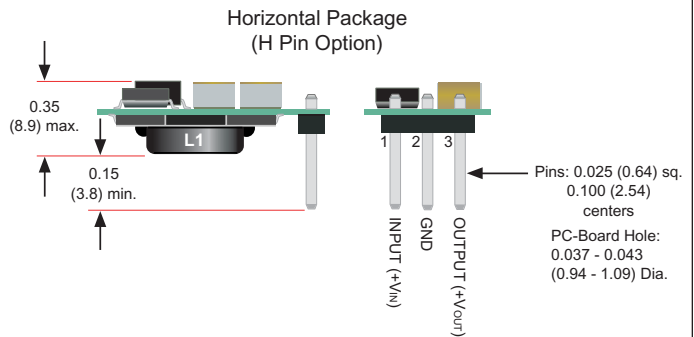
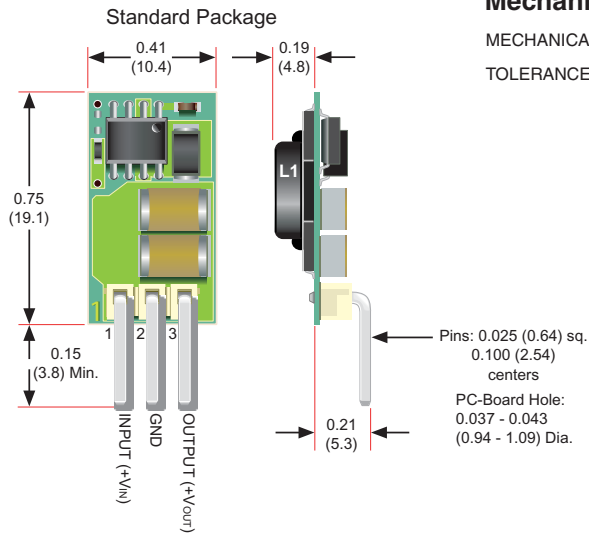

DATEL, Inc. 11 Cabot Boulevard, Mansfield, MA 02048-1151
 Tel: (508) 339-3000 (800) 233-2765 Fax: (508) 339-6356
 www.datel.com E-mail: sales@datel.com
 www.cdpowerelectronics.com

ISO 9001:2000 REGISTERED

DS-0540C 9/04

DATEL (UK) LTD. Tadley, England Tel: (01256)-880444
 Internet: www.datel-europe.com E-mail: datel.ltd@datel.com

DATEL S.A.R.L. Montigny Le Bretonneux, France Tel: 01-34-60-01-01
 Internet: www.datel-europe.com E-mail: datel.sarl@datel.com

DATEL GmbH München, Germany Tel: 89-544334-0
 Internet: www.datel-europe.com E-mail: datel.gmbh@datel.com

DATEL KK Tokyo, Japan Tel: 3-3779-1031, Osaka Tel: 6-6354-2025
 Internet: www.datel-co.jp E-mail: salestko@datel.co.jp, salesosa@datel.co.jp

DATEL China Shanghai, China Tel: 011-86-51317131
 E-mail: davidx@datel.com

DATEL makes no representation that the use of its products in the circuits described herein, or the use of other technical information contained herein, will not infringe upon existing or future patent rights. The descriptions contained herein do not imply the granting of licenses to make, use, or sell equipment constructed in accordance therewith. Specifications are subject to change without notice. The DATEL logo is a registered DATEL, Inc. trademark.