

LM95214

Quad Remote Diode and Local Temperature Sensor with SMBus Interface

General Description

LM95214 is an 11-bit digital temperature sensor with a 2-wire System Management Bus (SMBus) interface that can very accurately monitor the temperature of four remote diodes as well as its own temperature. The four remote diodes can be external devices such as microprocessors, graphics processors that target the ideality of a 2N3904 transistor or diode-connected 2N3904s.

The LM95214 reports temperature in two different formats for +127.875°C/-128°C range and 0°C/255°C range. The LM95214 $\overline{\text{TCRIT1}}$, $\overline{\text{TCRIT2}}$ and $\overline{\text{TCRIT3}}$ outputs are triggered when any unmasked channel exceeds its corresponding programmable limit and can be used to shutdown the system, to turn on the system fans or as a microcontroller interrupt function. The current status of the $\overline{\text{TCRIT1}}$, $\overline{\text{TCRIT2}}$ and $\overline{\text{TCRIT3}}$ pins can be read back from the status registers. Mask registers are available for further control of the $\overline{\text{TCRIT}}$ outputs.

Two LM95214 remote temperature channels have programmable digital filters while the other two remote channels utilize a fault-queue to minimize unwanted $\overline{\text{TCRIT}}$ events when temperature spikes are encountered.

For optimum flexibility and accuracy, each LM95214 channel includes registers for offset correction. A three-level address pin allows connection of up to 3 LM95214s to the same SMBus master. The LM95214 includes power saving functions such as: programmable conversion rate, shutdown mode, and disabling of unused channels.

Features

- Accurately senses die temperature of 4 remote ICs or diode junctions and local temperature
- Programmable digital filters and analog front end filter

- 0.125°C LSb temperature resolution
- 0.03125°C LSb remote temperature resolution with digital filter enabled
- +127.875°C/-128°C and 0°C/255°C remote ranges
- Remote diode fault detection, model selection and offset correction
- Mask and status register support
- 3 programmable $\overline{\text{TCRIT}}$ outputs with programmable shared hysteresis and Fault-Queue
- Programmable conversion rate and shutdown mode one-shot conversion control
- SMBus 2.0 compatible interface, supports TIMEOUT
- Three-level address pin
- 14-pin LLP package

Key Specifications

- | | |
|-------------------------------------|---------------|
| ■ Local Temperature Accuracy | ±2.0°C (max) |
| ■ Remote Diode Temperature Accuracy | ±1.1°C (max) |
| ■ Supply Voltage | 3.0V to 3.6V |
| ■ Average Supply Current | 0.57 mA (typ) |
| (1Hz conversion rate) | |

Applications

- Processor/Computer System Thermal Management (e.g. Laptop, Desktop, Workstations, Server)
- Electronic Test Equipment
- Office Electronics

Connection Diagram

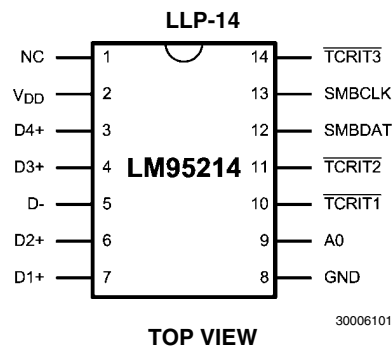

Ordering Information

Part Number	Package Marking	NS Package Number	Transport Media
LM95214CISD	95214CI	SDA14B (LLP-14)	1000 Units on Tape and Reel
LM95214CISDX	95214CI	SDA14B (LLP-14)	4500 Units on Tape and Reel

Simplified Block Diagram

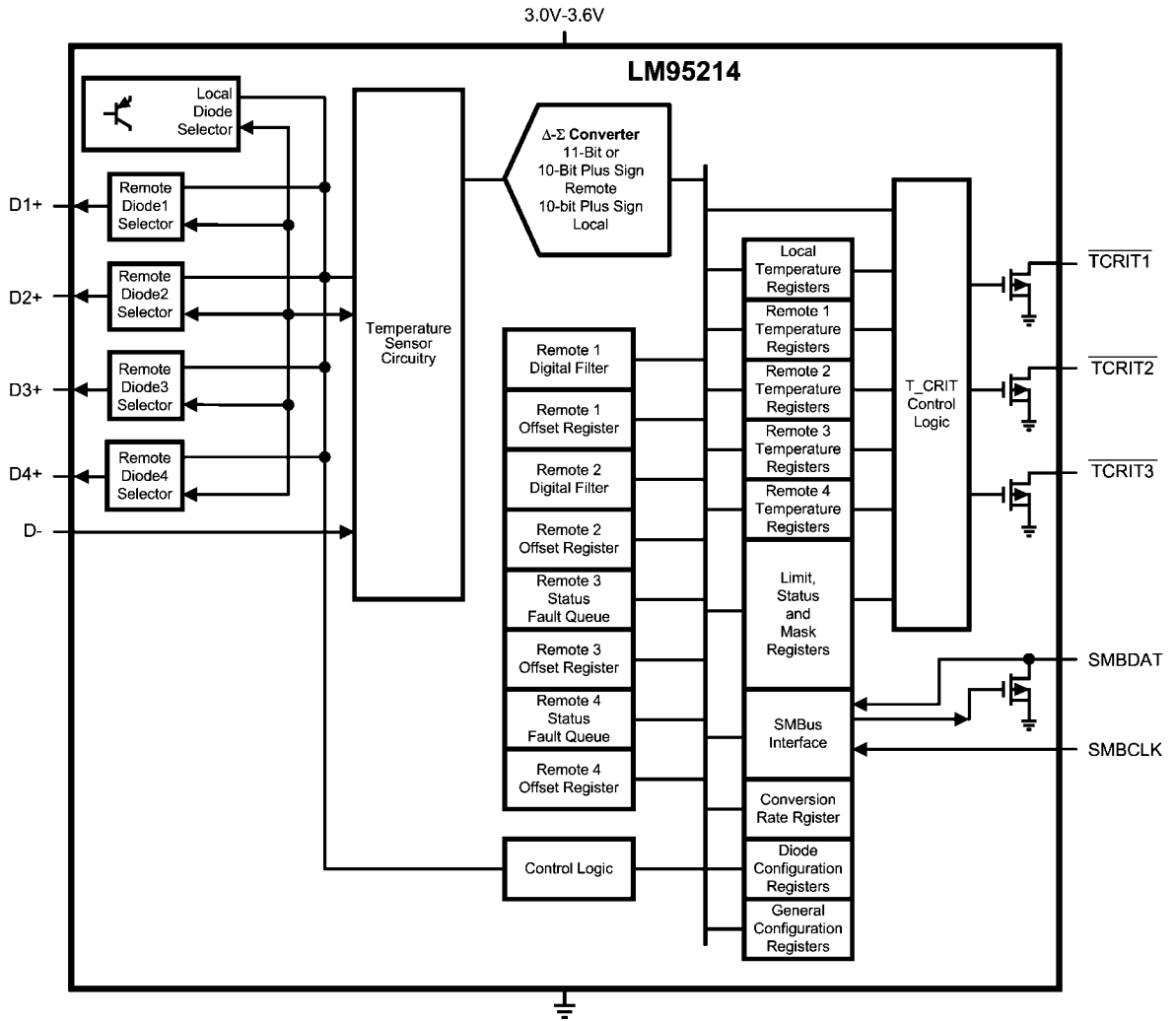

30006102

Pin Descriptions

Label	Pin #	Function	Typical Connection
NC	1	No Connect	Not connected. May be left floating, connected to GND or V_{DD} .
V_{DD}	2	Positive Supply Voltage Input	DC Voltage from 3.0V to 3.6V. V_{DD} should be bypassed with a 0.1 μ F capacitor in parallel with 100 pF. The 100 pF capacitor should be placed as close as possible to the power supply pin. Noise should be kept below 200 mVp-p, a 10 μ F capacitor may be required to achieve this.
D4+	3	Diode Current Source	Fourth Diode Anode. Connected to remote discrete diode-connected transistor junction or to the diode-connected transistor junction on a remote IC whose die temperature is being sensed. A capacitor is not required between D4+ and D-. A 100 pF capacitor between D4+ and D- can be added and may improve performance in noisy systems. Float this pin if this thermal diode is not used.
D3+	4	Diode Current Source	Third Diode Anode. Connected to remote discrete diode-connected transistor junction or to the diode-connected transistor junction on a remote IC whose die temperature is being sensed. A capacitor is not required between D3+ and D-. A 100 pF capacitor between D3+ and D- can be added and may improve performance in noisy systems. Float this pin if this thermal diode is not used.
D-	5	Diode Return Current Sink	All Diode Cathodes. Common D- pin for all four remote diodes.
D2+	6	Diode Current Source	Second Diode Anode. Connected to remote discrete diode-connected transistor junction or to the diode-connected transistor junction on a remote IC whose die temperature is being sensed. A capacitor is not required between D2+ and D-. A 100 pF capacitor between D2+ and D- can be added and may improve performance in noisy systems. Float this pin if this thermal diode is not used.
D1+	7	Diode Current Source	First Diode Anode. Connected to remote discrete diode-connected transistor junction or to the diode-connected transistor junction on a remote IC whose die temperature is being sensed. A capacitor is not required between D1+ and D-. A 100 pF capacitor between D1+ and D- can be added and may improve performance in noisy systems. Float this pin if this thermal diode is not used.
GND	8	Power Supply Ground	System low noise ground.
A0	9	Digital Input	SMBus slave address select pin. Selects one of three addresses. Can be tied to V_{DD} , GND, or to the middle of a resistor divider connected between V_{DD} and GND.
$\overline{\text{TCRIT1}}$	10	Digital Output, Open-Drain	Critical temperature output 1. Requires pull-up resistor. Active "LOW".
$\overline{\text{TCRIT2}}$	11	Digital Output, Open-Drain	Critical temperature output 2. Requires pull-up resistor. Active "LOW".
SMBDAT	12	SMBus Bidirectional Data Line, Open-Drain Output	From and to Controller; may require an external pull-up resistor
SMBCLK	13	SMBus Clock Input	From Controller; may require an external pull-up resistor
$\overline{\text{TCRIT3}}$	14	Digital Output, Open-Drain	Critical temperature output 3. Requires pull-up resistor. Active "LOW".

Typical Application

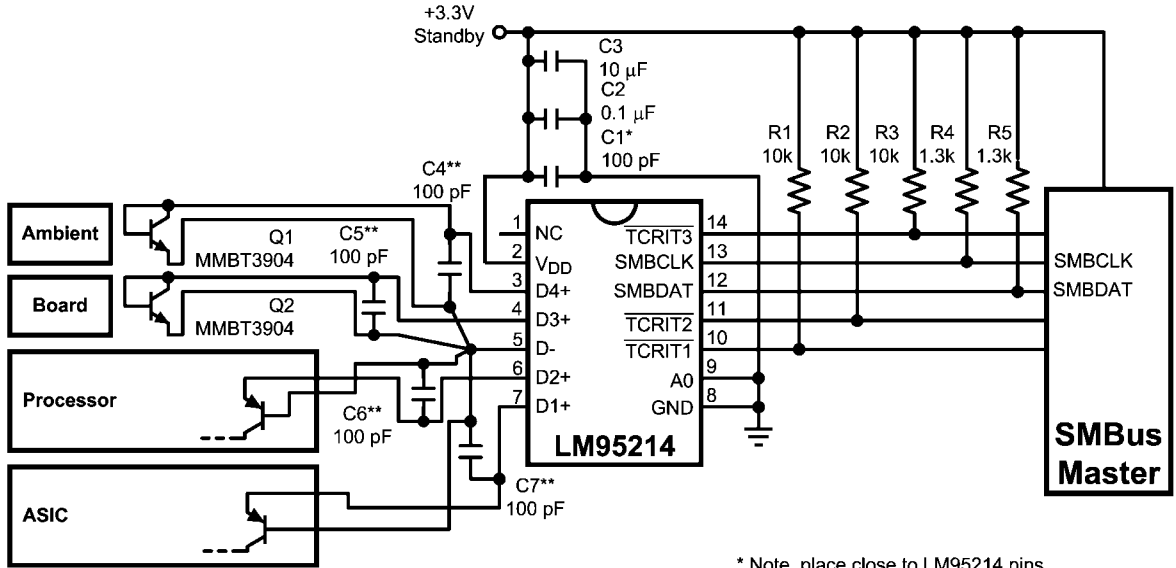

* Note, place close to LM95214 pins.

** Note, optional - place close to LM95214 pins.

30006103

Absolute Maximum Ratings (Note 1)

Supply Voltage	-0.3V to 6.0V
Voltage at SMBDAT, SMBCLK, TCRIT1, TCRIT2, TCRIT3	-0.5V to 6.0V
Voltage at Other Pins	-0.3V to ($V_{DD} + 0.3V$)
D- Input Current	±1 mA
Input Current at All Other Pins (Note 2)	±5 mA
Package Input Current (Note 2)	30 mA
SMBDAT, TCRIT1, TCRIT2, TCRIT3 Output Sink Current	10 mA
Storage Temperature	-65°C to +150°C
ESD Susceptibility (Note 4)	
Human Body Model	2000V
Machine Model	200V

Charge Device Model 1000V

Soldering process must comply with National's reflow temperature profile specifications. Refer to <http://www.national.com/packaging/>. (Note 3)

Operating Ratings

(Notes 1, 5)	
Operating Temperature Range	-40°C to +140°C
Electrical Characteristics Temperature Range	$T_{MIN} \leq T_A \leq T_{MAX}$
LM95214CISD	-40°C $\leq T_A \leq$ +125°C
Supply Voltage Range (V_{DD})	+3.0V to +3.6V

Temperature-to-Digital Converter Electrical Characteristics

Unless otherwise noted, these specifications apply for $V_{DD} = +3.0Vdc$ to 3.6Vdc. **Boldface limits apply for $T_A = T_J = T_{MIN} \leq T_A \leq T_{MAX}$** ; all other limits $T_A = T_J = +25^\circ C$, unless otherwise noted.

Parameter	Conditions	Typical (Note 6)	Limits (Note 7)	Units (Limit)
Temperature Error Using Local Diode	$T_A = -40^\circ C$ to $+125^\circ C$, (Note 8)	±1	±2	°C (max)
Temperature Error Using an MMBT3904 Transistor Remote Diode (Note 9)	$T_A = +25^\circ C$ to $+85^\circ C$ $T_D = +60^\circ C$ to $+100^\circ C$		±1.1	°C (max)
	$T_A = +25^\circ C$ to $+85^\circ C$ $T_D = -40^\circ C$ to $+125^\circ C$		±1.3	°C (max)
	$T_A = -40^\circ C$ to $+85^\circ C$ $T_D = -40^\circ C$ to $+125^\circ C$		±3.0	°C (max)
	$T_A = -40^\circ C$ to $+85^\circ C$ $T_D = 125^\circ C$ to $+140^\circ C$		±3.3	°C (max)
Local Diode Measurement Resolution		11		Bits
		0.125		°C
Remote Diode Measurement Resolution	Digital Filter Off	11		Bits
		0.125		°C
	Digital Filter On (Remote Diodes 1 and 2 only)	13		Bits
		0.03125		°C
Conversion Time of All Temperatures at the Fastest Setting (Note 11)	All Channels are Enabled in Default State	1100	1210	ms (max)
	1 External Channel	31	34	ms (max)
	Local only	30	33	ms (max)
Quiescent Current (Note 10)	SMBus Inactive, 1Hz Conversion Rate, channels in default state	570	800	µA (max)
	Shutdown	360		µA
D- Source Voltage		0.4		V
Remote Diode Source Current	High level	160	230	µA (max)
	Low level	10		
Power-On Reset Threshold	Measured on V_{DD} input, falling edge		2.8	V (max)
			1.6	V (min)
TCRIT1 Pin Temperature Threshold	Default Diodes 1 and 2 only	+110		°C
TCRIT2 Pin Temperature Threshold	Default all channels	+85		°C
TCRIT3 Pin Temperature Threshold	Default Diodes 3 and 4 only	+85		°C

Logic Electrical Characteristics

DIGITAL DC CHARACTERISTICS

Unless otherwise noted, these specifications apply for $V_{DD} = +3.0V_{dc}$ to $3.6V_{dc}$. **Boldface limits apply for $T_A = T_J = T_{MIN}$ to T_{MAX}** ; all other limits $T_A = T_J = +25^\circ C$, unless otherwise noted.

Symbol	Parameter	Conditions	Typical (Note 6)	Limits (Note 7)	Units (Limit)
SMBDAT, SMBCLK INPUTS					
$V_{IN(1)}$	Logical "1" Input Voltage			2.1	V (min)
$V_{IN(0)}$	Logical "0" Input Voltage			0.8	V (max)
$V_{IN(HYST)}$	SMBDAT and SMBCLK Digital Input Hysteresis		400		mV
$I_{IN(1)}$	Logical "1" Input Current	$V_{IN} = V_{DD}$	0.005	10	μA (max)
$I_{IN(0)}$	Logical "0" Input Current	$V_{IN} = 0V$	-0.005	-10	μA (max)
C_{IN}	Input Capacitance		5		pF
A0 DIGITAL INPUT					
V_{IH}	Input High Voltage			$0.90 \times V_{DD}$	V (min)
V_{IM}	Input Middle Voltage			$0.57 \times V_{DD}$	V (max)
				$0.43 \times V_{DD}$	V (min)
V_{IL}	Input Low Voltage			$0.10 \times V_{DD}$	V (max)
$I_{IN(1)}$	Logical "1" Input Current	$V_{IN} = V_{DD}$	-0.005	-10	μA (min)
$I_{IN(0)}$	Logical "0" Input Current	$V_{IN} = 0V$	0.005	10	μA (max)
C_{IN}	Input Capacitance		5		pF
SMBDAT, $\overline{TCRIT1}$, $\overline{TCRIT2}$, $\overline{TCRIT3}$ DIGITAL OUTPUTS					
I_{OH}	High Level Output Current	$V_{OH} = V_{DD}$		10	μA (max)
$V_{OL(SMBDAT)}$	SMBus Low Level Output Voltage	$I_{OL} = 4 \text{ mA}$ $I_{OL} = 6 \text{ mA}$		0.4	V (max)
				0.6	V (max)
$V_{OL(\overline{TCRIT})}$	$\overline{TCRIT1}$, $\overline{TCRIT2}$, $\overline{TCRIT3}$ Low Level Output Voltage	$I_{OL} = 6 \text{ mA}$		0.4	V (max)
C_{OUT}	Digital Output Capacitance		5		pF

SMBus DIGITAL SWITCHING CHARACTERISTICS

Unless otherwise noted, these specifications apply for $V_{DD}=+3.0$ Vdc to $+3.6$ Vdc, C_L (load capacitance) on output lines = 80 pF. **Boldface limits apply for $T_A = T_J = T_{MIN}$ to T_{MAX}** ; all other limits $T_A = T_J = +25^\circ\text{C}$, unless otherwise noted.

The switching characteristics of the LM95214 fully meet or exceed the published specifications of the SMBus version 2.0. The following parameters are the timing relationships between SMBCLK and SMBDAT signals related to the LM95214. They adhere to but are not necessarily the SMBus bus specifications.

Symbol	Parameter	Conditions	Typical (Note 6)	Limits (Note 7)	Units (Limit)
f_{SMB}	SMBus Clock Frequency			100 10	kHz (max) kHz (min)
t_{LOW}	SMBus Clock Low Time	from $V_{IN(0)}$ max to $V_{IN(0)}$ max		4.7 25	μs (min) ms (max)
t_{HIGH}	SMBus Clock High Time	from $V_{IN(1)}$ min to $V_{IN(1)}$ min		4.0	μs (min)
$t_{R,SMB}$	SMBus Rise Time	(Note 12)	1		μs (max)
$t_{F,SMB}$	SMBus Fall Time	(Note 13)	0.3		μs (max)
t_{OF}	Output Fall Time	$C_L = 400$ pF, $I_O = 3$ mA, (Note 13)		250	ns (max)
$t_{TIMEOUT}$	SMBDAT and SMBCLK Time Low for Reset of Serial Interface (Note 14)			25 35	ms (min) ms (max)
$t_{SU,DAT}$	Data In Setup Time to SMBCLK High			250	ns (min)
$t_{HD,DAT}$	Data Out Stable after SMBCLK Low			300 1075	ns (min) ns (max)
$t_{HD,STA}$	Start Condition SMBDAT Low to SMBCLK Low (Start condition hold before the first clock falling edge)			100	ns (min)
$t_{SU,STO}$	Stop Condition SMBCLK High to SMBDAT Low (Stop Condition Setup)			100	ns (min)
$t_{SU,STA}$	SMBus Repeated Start-Condition Setup Time, SMBCLK High to SMBDAT Low			0.6	μs (min)
t_{BUF}	SMBus Free Time Between Stop and Start Conditions			1.3	μs (min)

SMBus Communication

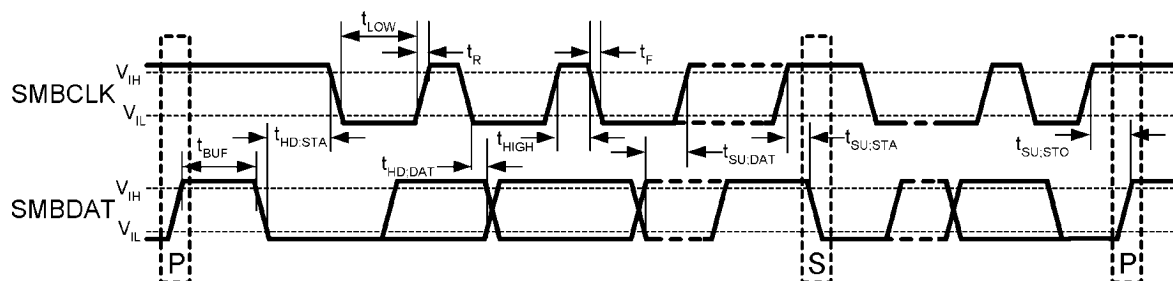

30006109

Note 1: Absolute Maximum Ratings indicate limits beyond which damage to the device may occur. DC and AC electrical specifications do not apply when operating the device beyond its rated operating conditions.

Note 2: When the input voltage (V_I) at any pin exceeds the power supplies ($V_I < \text{GND}$ or $V_I > V_{DD}$), the current at that pin should be limited to 5 mA. Parasitic components and or ESD protection circuitry are shown in the table below for the LM95214's pins.

Pin #	Label	Circuit	Circuits for Pin ESD Protection Structure
1	NC	–	<p>Circuit A</p> <p>Circuit B</p>
2	V _{DD}	A	
3	D4+	A	
4	D3+	A	
5	D-	A	
6	D2+	A	
7	D1+	A	
8	GND	–	
9	A0	B	
10	$\overline{\text{TCRIT1}}$	B	
11	$\overline{\text{TCRIT2}}$	B	
12	SMBDAT	B	
13	SMBCLK	B	
14	$\overline{\text{TCRIT2}}$	B	

Note 3: Reflow temperature profiles are different for packages containing lead (Pb) than for those that do not.

Note 4: Human body model, 100 pF discharged through a 1.5 k Ω resistor. Machine model, 200 pF discharged directly into each pin. Charged Device Model (CDM) simulates a pin slowly acquiring charge (such as from a device sliding down the feeder in an automated assembler) then rapidly being discharged.

Note 5: Thermal resistance junction-to-ambient when attached to a 4 layer printed circuit board per JEDEC standard JESD51-7:

- 14-lead LLP = 90°C/W (no thermal vias, no airflow)
- 14-lead LLP = 63°C/W (1 thermal via, no airflow)
- 14-lead LLP = 43°C/W (6 thermal vias, no airflow)
- 14-lead LLP = 31°C/W (6 thermal vias, 900 In. ft. / min. airflow)

Note, all quoted values include +15% error factor from nominal value.

Note 6: Typical values are at T_A = 25°C and represent most likely parametric norm.

Note 7: Limits are guaranteed to National's AOQL (Average Outgoing Quality Level).

Note 8: Local temperature accuracy does not include the effects of self-heating. The rise in temperature due to self-heating is the product of the internal power dissipation of the LM95214 and the thermal resistance. See (Note 5) for the thermal resistance to be used in the self-heating calculation.

Note 9: The accuracy of the LM95214CISD is guaranteed when using a typical MMBT3904 diode-connected transistor. For further information on other thermal diodes see applications Section 3.1 "Diode Non-ideality" or send email to hardware.monitor.team@national.com.

Note 10: Quiescent current will not increase substantially with an SMBus communication.

Note 11: This specification is provided only to indicate how often temperature data is updated. The LM95214 can be read at any time without regard to conversion state (and will yield last conversion result).

Note 12: The output rise time is measured from (V_{IN(0)}max – 0.15V) to (V_{IN(1)}min + 0.15V).

Note 13: The output fall time is measured from (V_{IN(1)}min + 0.15V) to (V_{IN(0)}max – 0.15V).

Note 14: Holding the SMBDAT and/or SMBCLK lines Low for a time interval greater than t_{TIMEOUT} will reset the LM95214's SMBus state machine, therefore setting SMBDAT and SMBCLK pins to a high impedance state.

Typical Performance Characteristics

Conversion Rate Effect on Average Power Supply Current

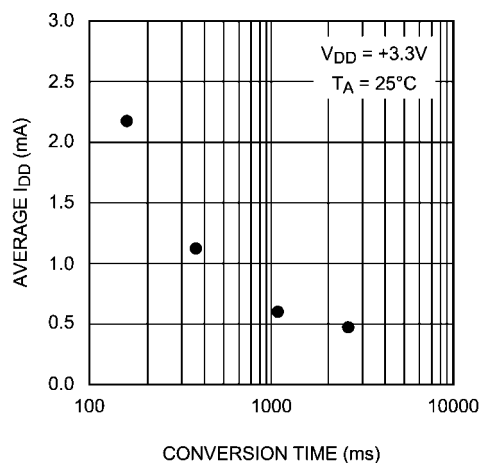

30006106

Thermal Diode Capacitor or PCB Leakage Current Effect on Remote Diode Temperature Reading

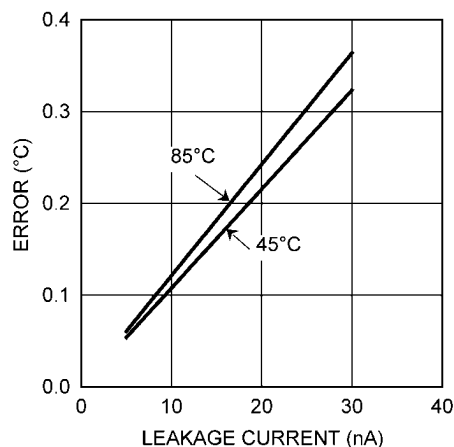

30006123

Remote Temperature Reading Sensitivity to Thermal Diode Filter Capacitance

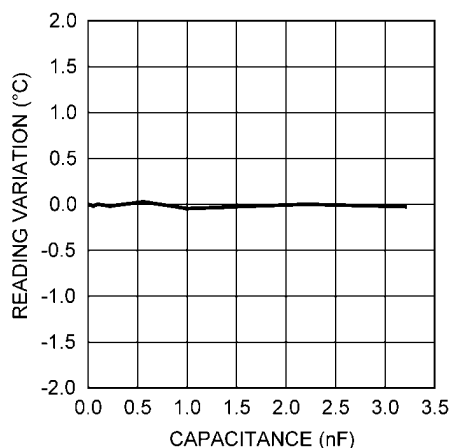

30006107

1.0 Functional Description

LM95214 is an 11-bit digital temperature sensor with a 2-wire System Management Bus (SMBus) interface that can monitor the temperature of four remote diodes as well as its own temperature. The LM95214 can be used to very accurately monitor the temperature of up to four external devices such as microprocessors, graphics processors or diode-connected 2N3904 transistor. Any device whose thermal diode can be modeled by an MMBT3904 transistor will work well with the LM95214.

The LM95214 reports temperature in two different formats for +127.875 $^\circ C$ /-128 $^\circ C$ range and 0 $^\circ C$ /255 $^\circ C$ range. The LM95214 has a Sigma-Delta ADC (Analog-to-Digital Converter) core which provides the first level of noise immunity. For improved performance in a noisy environment the LM95214 includes programmable digital filters for Remote Diode 1 and 2 temperature readings. When the digital filters are invoked the resolution for Remote Diode 1 and 2 readings increases to 0.03125 $^\circ C$. For maximum flexibility and best accuracy the LM95214 includes offset registers that allow calibration of other diode types.

Diode fault detection circuitry in the LM95214 can detect the absence or fault state of a remote diode: whether D+ is shorted to V_{DD} , D- or ground, or whether D+ is floating.

The LM95214 $\overline{TCRIT1}$, $\overline{TCRIT2}$ and $\overline{TCRIT3}$ active low outputs are triggered when any unmasked channel exceeds its corresponding programmable limit and can be used to shut-down the system, to turn on the system fans or as a microcontroller interrupt function. The current status of the $\overline{TCRIT1}$, $\overline{TCRIT2}$ and $\overline{TCRIT3}$ pins can be read back from the status registers via the SMBus interface. Two of the remote channels have two separate limits each that control the $\overline{TCRIT1}$ and $\overline{TCRIT2}$ pins. The remaining two channels and the local channel each have one limit to control both the $\overline{TCRIT1}$ and $\overline{TCRIT2}$ pins. The $\overline{TCRIT3}$ pin shares the limits of the $\overline{TCRIT2}$ pin but allows for different masking options. All limits have a shared programmable hysteresis register.

Remote Diode 1 and 2 temperature channels have programmable digital filters while the other two remote temperature channels utilize a fault-queue in order to avoid false triggering the \overline{TCRIT} pins.

LM95214 has a three-level address pin to connect up to 3 devices to the same SMBus master. LM95214 also has pro-

grammable conversion rate register as well as a shutdown mode for power savings. One round of conversions can be triggered in shutdown mode by writing to the one-shot register through the SMBus interface. LM95214 can be programmed to turn off unused channels for more power savings.

The LM95214 register set has an 8-bit data structure and includes:

1. Temperature Value Registers with signed format
 - Most-Significant-Byte (MSB) and Least-Significant-Byte (LSB) Local Temperature
 - MSB and LSB Remote Temperature 1
 - MSB and LSB Remote Temperature 2
 - MSB and LSB Remote Temperature 3
 - MSB and LSB Remote Temperature 4
2. Temperature Value Registers with unsigned format
 - MSB and LSB Remote Temperature 1
 - MSB and LSB Remote Temperature 2
 - MSB and LSB Remote Temperature 3
 - MSB and LSB Remote Temperature 4
3. Diode Configuration Registers
 - Diode Model Select
 - Remote 1 Offset
 - Remote 2 Offset
 - Remote 3 Offset
 - Remote 4 Offset
4. General Configuration Registers
 - Configuration (Standby, Fault Queue enable for Remote 3 and 4; Conversion Rate)
 - Channel Conversion Enable
 - Filter Setting for Remote 1 and 2
 - 1-Shot
5. Status Registers
 - Main Status Register (Busy bit, Not Ready, Status Register 1 to 4 Flags)
 - Status 1 (diode fault)
 - Status 2 (TCRIT1)
 - Status 3 (TCRIT2)
 - Status 4 (TCRIT3)
6. Mask Registers
 - TCRIT1 Mask
 - TCRIT2 Mask
 - TCRIT3 Mask
7. Limit Registers
 - Local Tcrit Limit
 - Remote 1 Tcrit-1 Limit
 - Remote 2 Tcrit-1 Limit
 - Remote 3 Tcrit Limit
 - Remote 4 Tcrit Limit
 - Remote 1 Tcrit-2 and Tcrit-3 Limit
 - Remote 2 Tcrit-2 and Tcrit-3 Limit
 - Common Tcrit Hysteresis
8. Manufacturer ID Register
9. Revision ID Register

1.1 CONVERSION SEQUENCE

The LM95214 takes approximately 190 ms to convert the Local Temperature, Remote Temperatures 1 through 4, and to update all of its registers. These conversions for each thermal diode are addressed in a round robin sequence. Only during

the conversion process the busy bit (D7) in Status register (02h) is high. The conversion rate may be modified by the Conversion Rate bits found in the Configuration Register (03h). When the conversion rate is modified a delay is inserted between each round of conversions, the actual time for each round remains at 190 ms (typical all channels enabled). The time a round takes depends on the number of channels that are on. Different conversion rates will cause the LM95214 to draw different amounts of average supply current as shown in Figure 1. This curve assumes all the channels are on. If channels are turned off the average current will drop since the round robin time will decrease and the shutdown time will increase during each conversion interval.

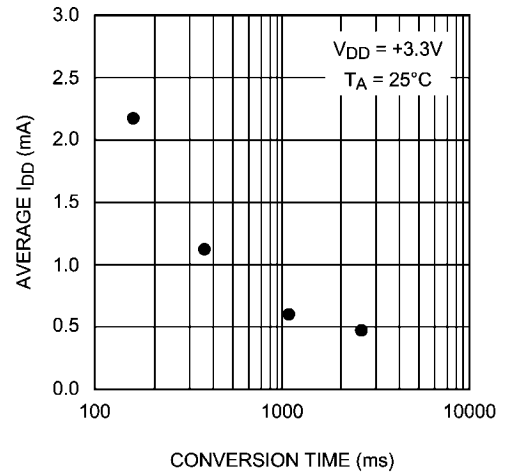

FIGURE 1. Conversion Rate Effect on Power Supply Current

1.2 POWER-ON-DEFAULT STATES

LM95214 always powers up to these known default states. The LM95214 remains in these states until after the first conversion.

1. All Temperature readings set to 0°C until the end of the first conversion
2. Remote offset for all channels 0°C
3. Configuration: Active converting, Fault Queue enabled for Remote 3 and 4
4. Continuous conversion with all channels enabled, time = 1s
5. Enhanced digital filter enabled for Remote 1 and 2
6. Status Registers depends on state of thermal diode inputs
7. Local and Remote Temperature Limits for $\overline{\text{TCRIT1}}$, $\overline{\text{TCRIT2}}$ and $\overline{\text{TCRIT3}}$ outputs:

Output Pin	Temperature Channel Limit				
	Remote 4 (°C)	Remote 3 (°C)	Remote 2 (°C)	Remote 1 (°C)	Local (°C)
$\overline{\text{TCRIT1}}$	Masked, 85	Masked, 85	110	110	Masked, 85
$\overline{\text{TCRIT2}}$	85	85	85	85	85
$\overline{\text{TCRIT3}}$	85	85	Masked, 85	Masked, 85	Masked, 85

8. Manufacturers ID set to 01h

9. Revision ID set to 7Bh

1.3 SMBus INTERFACE

The LM95214 operates as a slave on the SMBus, so the SMBCLK line is an input and the SMBDAT line is bidirectional. The LM95214 never drives the SMBCLK line and it does not support clock stretching. According to SMBus specifications, the LM95214 has a 7-bit slave address. Three SMBus device address can be selected by connecting A0 (pin 6) to either Low, Mid-Supply or High voltages. The LM95214 has the following SMBus slave address:

A0 Pin State	SMBus Device Address A[6:0]	
	Hex	Binary
Low	18h	001 1000
Mid-Supply	4Dh	100 1101
High	4Eh	100 1110

1.4 TEMPERATURE CONVERSION SEQUENCE

Each of the 5 temperature channels of LM95214 can be turned OFF independent from each other via the Channel Enable Register. Turning off unused channels will increase the conversion speed in the fastest conversion speed mode. If the slower conversion speed settings are used, disabling

unused channels will reduce the average power consumption of LM95214.

1.4.1 Digital Filter

In order to suppress erroneous remote temperature readings due to noise as well as increase the resolution of the temperature, the LM95214 incorporates a digital filter for Remote 1 and 2 Temperature Channels. When a filter is enabled the filtered readings are used for the TCRIT comparisons. There are two possible digital filter settings that are enabled through the Filter Setting Register at register address 0Fh. The filter for each channel can be set according to the following table:

R1F[1:0] or R2F[1:0]		Filter Setting
0	0	No Filter
0	1	Filter (equivalent to Level 2 filter of the LM86/LM89)
1	0	Reserved
1	1	Enhanced Filter (Filter with transient noise clipping)

Figure 2 describes the filter output in response to a step input and an impulse input.

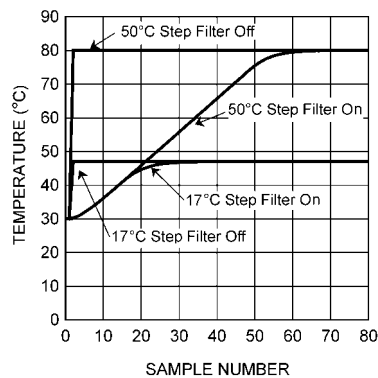

a) Seventeen and fifty degree step response 30006125

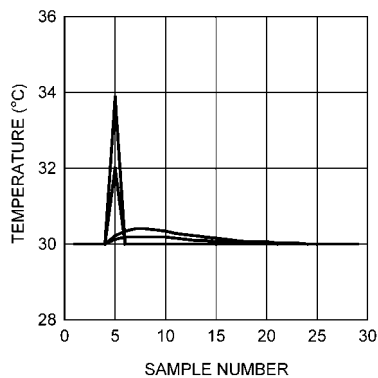

b) Impulse response with input transients less than 4°C 30006126

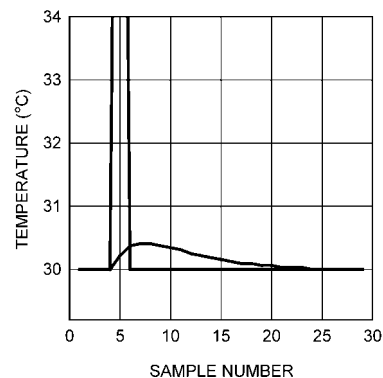

c) Impulse response with input transients greater than 4°C 30006127

FIGURE 2. Filter Impulse and Step Response Curves

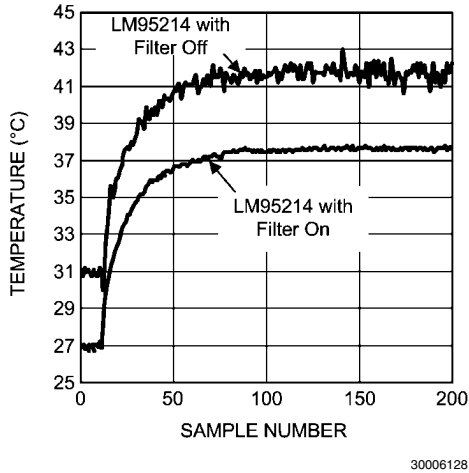

FIGURE 3. Digital Filter Response in a typical Intel processor on a 65 nm or 90 nm process. The filter curves were purposely offset for clarity.

Figure 3 shows the filter in use in a typical system. Note that the two curves have been purposely offset for clarity. Inserting the filter does not induce an offset as shown.

1.5 FAULT QUEUE

In order to suppress erroneous $\overline{\text{TCRIT1}}$, $\overline{\text{TCRIT2}}$ and $\overline{\text{TCRIT3}}$ triggering the LM95214 incorporates a Fault Queue for the unfiltered remote channels 3 and 4. The Fault Queue acts to ensure the remote temperature measurement of these channels is genuinely beyond the corresponding Tcrit limit by not triggering until three consecutive out of limit measurements have been made, see Figure 4 for an example. The Fault Queue defaults on upon power-up. The fault queue for channels 3 and 4 can be turned ON or OFF via bits 0 and 1 of the Configuration Register. When the fault queue is enabled, the $\overline{\text{TCRIT1}}$, $\overline{\text{TCRIT2}}$ and $\overline{\text{TCRIT3}}$ pins will be triggered if the temperature is above the Tcrit limit for 3 consecutive conversions and the corresponding mask bit is 0 in the TCRIT Mask registers. Similarly the temperature needs to be below the Tcrit limit minus the hysteresis value for three consecutive

conversions for the $\overline{\text{TCRIT1}}$, $\overline{\text{TCRIT2}}$ and $\overline{\text{TCRIT3}}$ pins to deactivate.

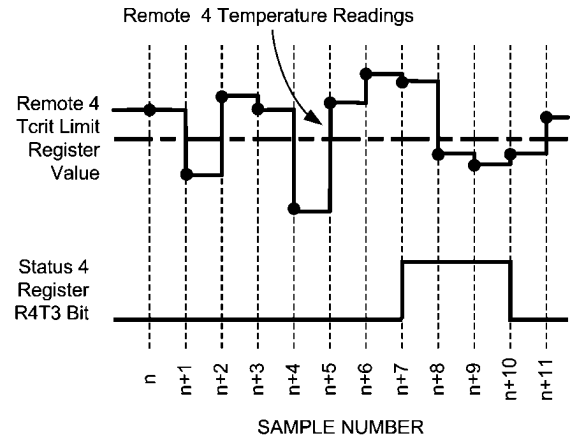

FIGURE 4. Fault Queue Response Diagram (with 0°C hysteresis)

1.6 TEMPERATURE DATA FORMAT

Temperature data can only be read from the Local and Remote Temperature value registers. The data format for all temperature values is left justified 16-bit word available in two 8-bit registers. Unused bits will always report "0". All temperature data is clamped and will not roll over when a temperature exceeds full-scale value.

Remote temperature data for all channels can be represented by an 11-bit, two's complement word or unsigned binary word with an LSb (Least Significant Bit) equal to 0.125°C.

11-bit, 2's complement (10-bit plus sign)

Temperature	Digital Output	
	Binary	Hex
+125°C	0111 1101 0000 0000	7D00h
+25°C	0001 1001 0000 0000	1900h
+1°C	0000 0001 0000 0000	0100h
+0.125°C	0000 0000 0010 0000	0020h
0°C	0000 0000 0000 0000	0000h
-0.125°C	1111 1111 1110 0000	FFE0h
-1°C	1111 1111 0000 0000	FF00h
-25°C	1110 0111 0000 0000	E700h
-55°C	1100 1001 0000 0000	C900h

11-bit, unsigned binary

Temperature	Digital Output	
	Binary	Hex
+255.875°C	1111 1111 1110 0000	FFE0h
+255°C	1111 1111 0000 0000	FF00h
+201°C	1100 1001 0000 0000	C900h
+125°C	0111 1101 0000 0000	7D00h
+25°C	0001 1001 0000 0000	1900h
+1°C	0000 0001 0000 0000	0100h

Temperature	Digital Output	
	Binary	Hex
+0.125°C	0000 0000 0010 0000	0020h
0°C	0000 0000 0000 0000	0000h

When the digital filter is enabled on Remote 1 and 2 channels temperature data is represented by a 13-bit unsigned binary or 12-bit plus sign (two's complement) word with an LSb equal to 0.03125°C.

13-bit, 2's complement (12-bit plus sign)

Temperature	Digital Output	
	Binary	Hex
+125°C	0111 1101 0000 0000	7D00h
+25°C	0001 1001 0000 0000	1900h
+1°C	0000 0001 0000 0000	0100h
+0.03125°C	0000 0000 0000 1000	0008h
0°C	0000 0000 0000 0000	0000h
-0.03125°C	1111 1111 1111 1000	FFF8h
-1°C	1111 1111 0000 0000	FF00h
-25°C	1110 0111 0000 0000	E700h
-55°C	1100 1001 0000 0000	C900h

13-bit, unsigned binary

Temperature	Digital Output	
	Binary	Hex
+255.875°C	1111 1111 1110 0000	FFE0h
+255°C	1111 1111 0000 0000	FF00h
+201°C	1100 1001 0000 0000	C900h
+125°C	0111 1101 0000 0000	7D00h
+25°C	0001 1001 0000 0000	1900h
+1°C	0000 0001 0000 0000	0100h
+0.03125°C	0000 0000 0000 1000	0008h
0°C	0000 0000 0000 0000	0000h

Local Temperature data is only represented by an 11-bit, two's complement, word with an LSb equal to 0.125°C.

11-bit, 2's complement (10-bit plus sign)

Temperature	Digital Output	
	Binary	Hex
+125°C	0111 1101 0000 0000	7D00h
+25°C	0001 1001 0000 0000	1900h
+1°C	0000 0001 0000 0000	0100h
+0.125°C	0000 0000 0010 0000	0020h

Temperature	Digital Output	
	Binary	Hex
0°C	0000 0000 0000 0000	0000h
-0.125°C	1111 1111 1110 0000	FFE0h
-1°C	1111 1111 0000 0000	FF00h
-25°C	1110 0111 0000 0000	E700h
-55°C	1100 1001 0000 0000	C900h

1.7 SMBDAT OPEN-DRAIN OUTPUT

The SMBDAT output is an open-drain output and does not have internal pull-ups. A "high" level will not be observed on this pin until pull-up current is provided by some external source, typically a pull-up resistor. Choice of resistor value depends on many system factors but, in general, the pull-up resistor should be as large as possible without effecting the SMBus desired data rate. This will minimize any internal temperature reading errors due to internal heating of the LM95214. The maximum resistance of the pull-up to provide a 2.1V high level, based on LM95214 specification for High Level Output Current with the supply voltage at 3.0V, is 82 k Ω (5%) or 88.7 k Ω (1%).

1.8 $\overline{\text{TCRIT1}}$, $\overline{\text{TCRIT2}}$, and $\overline{\text{TCRIT3}}$ OUTPUTS

The LM95214's $\overline{\text{TCRIT}}$ pins are active-low open-drain outputs and do not include internal pull-up resistors. A "high" level will not be observed on these pins until pull-up current is provided by some external source, typically a pull-up resistor. Choice of resistor value depends on many system factors but, in general, the pull-up resistor should be as large as possible without effecting the performance of the device receiving the signal. This will minimize any internal temperature reading errors due to internal heating of the LM95214. The maximum resistance of the pull-up to provide a 2.1V high level, based on LM95214 specification for High Level Output Current with the supply voltage at 3.0V, is 82 k Ω (5%) or 88.7 k Ω (1%). The three $\overline{\text{TCRIT}}$ pins can each sink 6 mA of current and still guarantee a "Logic Low" output voltage of 0.4V. If all three pins are set at maximum current this will cause a power dissipation of 7.2 mW. This power dissipation combined with a thermal resistance of 77.8°C/W will cause the LM95214's junction temperature to rise approximately 0.6°C and thus cause the Local temperature reading to shift. This can only be cancelled out if the environment that the LM95214 is enclosed in has stable and controlled air flow over the LM95214, as airflow can cause the thermal resistance to change dramatically.

1.9 Tcrit LIMITS AND $\overline{\text{TCRIT}}$ OUTPUTS

Figure 5 describes a simplified diagram of the temperature comparison and status register logic. Figure 6 describes a simplified logic diagram of the circuitry associated with the status registers, mask registers and the TCRIT output pins.

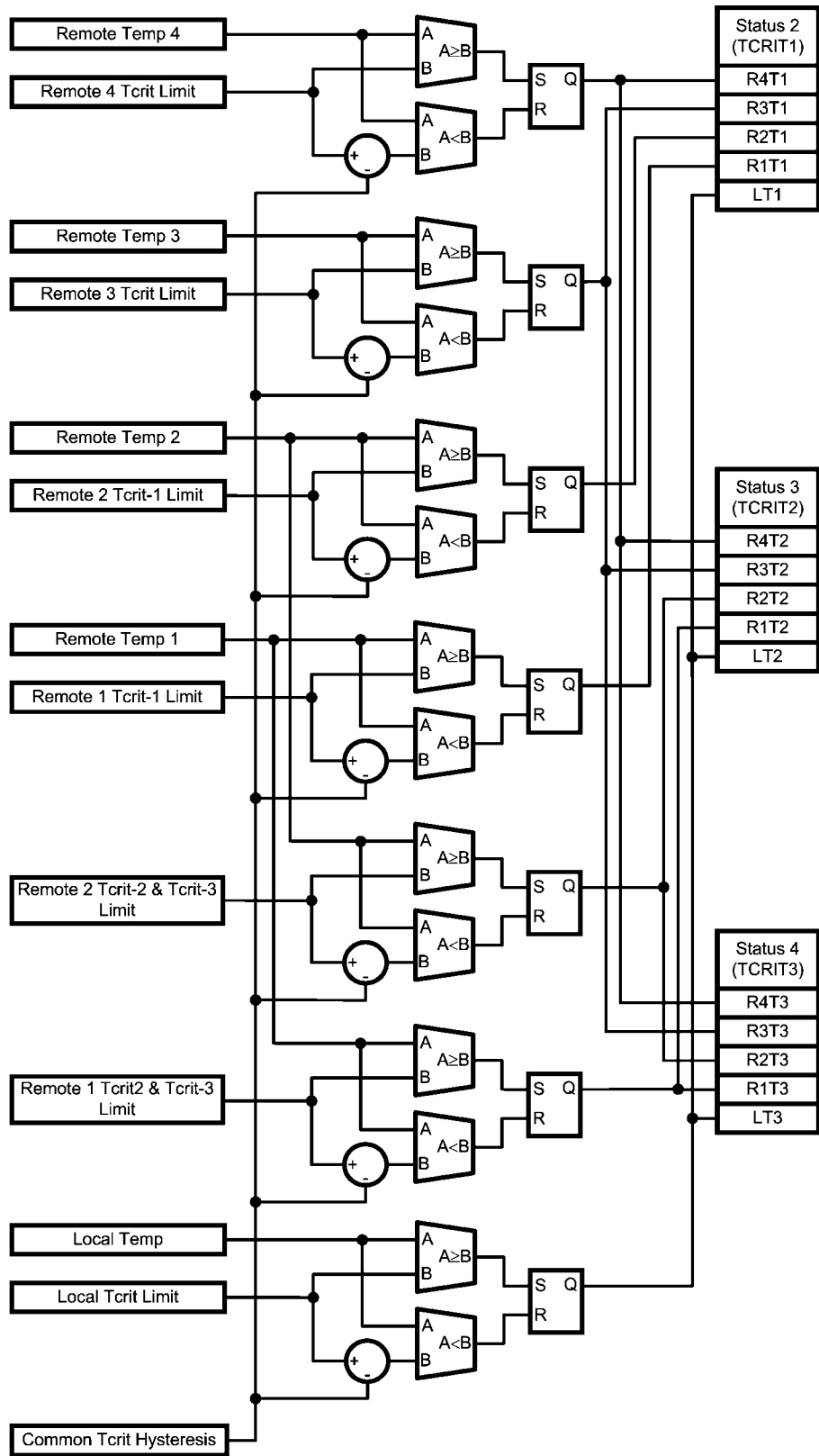

30006150

FIGURE 5. Temperature Comparison Logic and Status Register Simplified Diagram

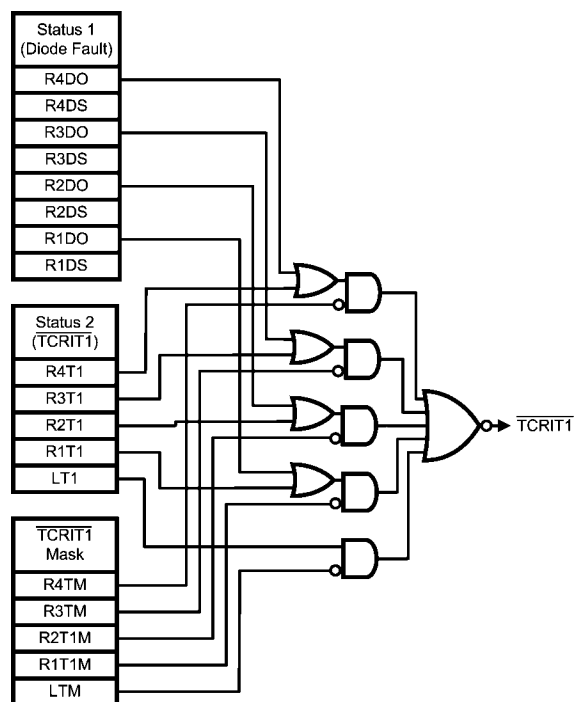

a) $\overline{\text{TCRIT1}}$ Mask Register, Status Register 1 and 2, and $\overline{\text{TCRIT1}}$ output logic diagram. 30006151

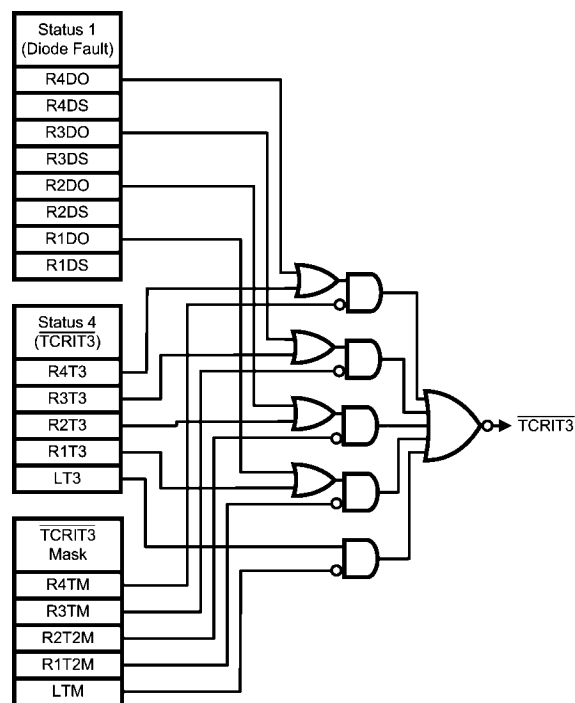

c) $\overline{\text{TCRIT3}}$ Mask Register, Status Register 1 and 4, and $\overline{\text{TCRIT3}}$ output logic diagram. 30006153

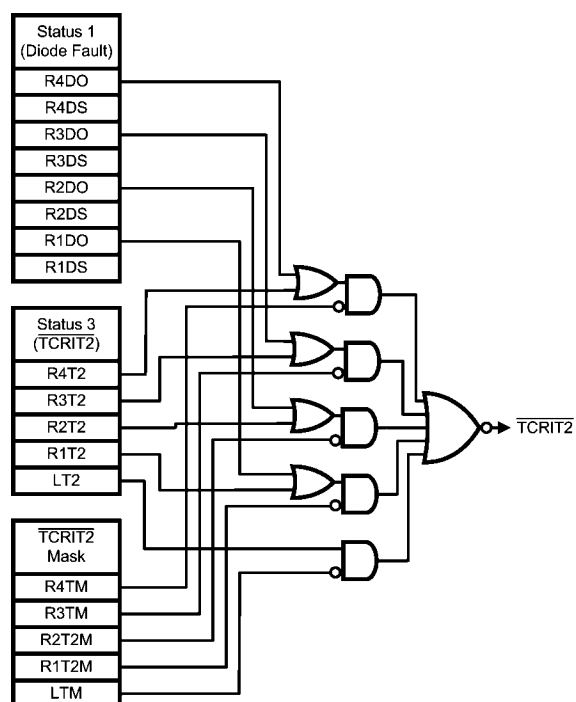

b) $\overline{\text{TCRIT2}}$ Mask Register, Status Register 1 and 3, and $\overline{\text{TCRIT2}}$ output logic diagram. 30006152

FIGURE 6. Logic diagrams for the $\overline{\text{TCRIT1}}$, $\overline{\text{TCRIT2}}$, and $\overline{\text{TCRIT3}}$ outputs.

If enabled, local temperature is compared to the user programmable Local Tcrit Limit Register (Default Value = 85°C). The result of this comparison is stored in Status Register 2, Status Register 3 and Status Register 4 (see Figure 5). The comparison result can trigger $\overline{\text{TCRIT1}}$ pin, $\overline{\text{TCRIT2}}$ pin or $\overline{\text{TCRIT3}}$ pin depending on the settings in the TCRIT1 Mask, TCRIT2 Mask and TCRIT3 Mask Registers (see Figure 6). The comparison result can also be read back from the Status Register 2, Status Register 3 and Status Register 4.

If enabled, remote temperature 1 is compared to the user programmable Remote 1 Tcrit-1 Limit Register (Default Value 110°C) and Remote 1 Tcrit-2 Limit Register (Default Value = 85°C). The result of this comparison is stored in Status Register 2, Status Register 3 and Status Register 4 (see Figure 5). The comparison result can trigger $\overline{\text{TCRIT1}}$ pin, $\overline{\text{TCRIT2}}$ pin or $\overline{\text{TCRIT3}}$ pin depending on the settings in the $\overline{\text{TCRIT1}}$ Mask, $\overline{\text{TCRIT2}}$ Mask and $\overline{\text{TCRIT3}}$ Mask Registers (see Figure 6). The comparison result can also be read back from the Status Register 2, Status Register 3 and Status Register 4. The remote temperature 2 operates in a similar manner to remote temperature 1 using its associated user programmable limit registers: Remote 2 Tcrit-1 Limit Register (Default Value 110°C) and Remote 2 Tcrit-2 Limit Register (Default Value = 85°C). When enabled, the remote temperature 3 is compared to the user programmable Remote 3 Tcrit Limit Register (Default Value 85°C). The comparison result can trigger $\overline{\text{TCRIT1}}$ pin, $\overline{\text{TCRIT2}}$ pin or $\overline{\text{TCRIT3}}$ pin depending on the settings in the $\overline{\text{TCRIT1}}$ Mask, $\overline{\text{TCRIT2}}$ Mask and $\overline{\text{TCRIT3}}$ Mask Registers. The comparison result can also be read back from the Status Register 2, Status Register 3 and Status Register 4. The remote temperature 4 operates in a similar manner to remote temperature 3 using its associated user programmable limit register: Remote 4 Tcrit Limit Register (Default Value 85°C).

Limit assignments for each $\overline{\text{TCRIT}}$ output pin:

	$\overline{\text{TCRIT1}}$	$\overline{\text{TCRIT2}}$	$\overline{\text{TCRIT3}}$
Remote 4	Remote 4 Tcrit Limit	Remote 4 Tcrit Limit	Remote 4 Tcrit Limit
Remote 3	Remote 3 Tcrit Limit	Remote 3 Tcrit Limit	Remote 3 Tcrit Limit
Remote 2	Remote 2 Tcrit-1 Limit	Remote 2 Tcrit-2 Limit	Remote 2 Tcrit-2 Limit
Remote 1	Remote 1 Tcrit-1 Limit	Remote 1 Tcrit-2 Limit	Remote 1 Tcrit-2 Limit
Local	Local Tcrit Limit	Local Tcrit Limit	Local Tcrit Limit

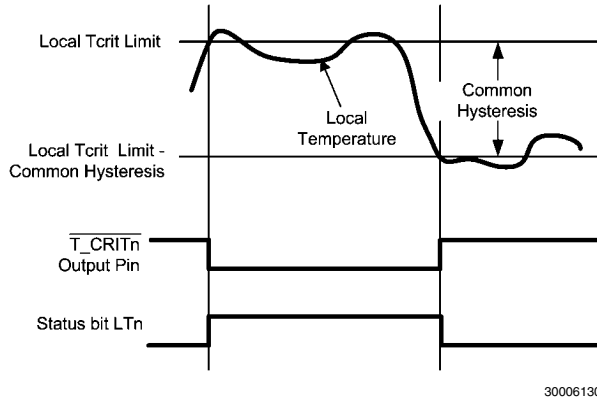

FIGURE 7. TCRIT response diagram (masking options not included)

The TCRIT response diagram of *Figure 7* shows the local temperature interaction with the Tcrit limit and hysteresis value. As can be seen in the diagram when the local temperature exceeds the Tcrit limit register value the $\overline{\text{LTn}}$ Status bit is set and the $\overline{\text{T_CRITn}}$ output(s) is/are activated. The Status bit(s) and outputs are not deactivated until the temperature goes below the value calculated by subtracting the Common Hysteresis value programmed from the limit. This diagram mainly shows an example function of the hysteresis and is not meant to show complete function of the possible settings and options of all the TCRIT outputs and limit values.

1.10 DIODE FAULT DETECTION

The LM95214 is equipped with operational circuitry designed to detect fault conditions concerning the remote diodes. In the

event that the D+ pin is detected as shorted to GND, D-, V_{DD} or D+ is floating, the Remote Temperature reading is $-128.000\text{ }^{\circ}\text{C}$ if signed format is selected and $0\text{ }^{\circ}\text{C}$ if unsigned format is selected. In addition, the appropriate status register bits RD1M or RD2M (D1 or D0) are set.

1.11 COMMUNICATING with the LM95214

The data registers in the LM95214 are selected by the Command Register. At power-up the Command Register is set to "00", the location for the Read Local Temperature Register. The Command Register latches the last location it was set to. Each data register in the LM95214 falls into one of three types of user accessibility:

1. Read only
2. Write only
3. Write/Read same address

A **Write** to the LM95214 will always include the address byte and the command byte. A write to any register requires one data byte.

Reading the LM95214 can take place either of two ways:

1. If the location latched in the Command Register is correct (most of the time it is expected that the Command Register will point to one of the Read Temperature Registers because that will be the data most frequently read from the LM95214), then the read can simply consist of an address byte, followed by retrieving the data byte.
2. If the Command Register needs to be set, then an address byte, command byte, repeat start, and another address byte will accomplish a read.

The data byte has the most significant bit first. At the end of a read, the LM95214 can accept either acknowledge or No Acknowledge from the Master (No Acknowledge is typically used as a signal for the slave that the Master has read its last byte). It takes the LM95214 190 ms (typical, all channels enabled) to measure the temperature of the remote diodes and internal diode. When retrieving all 11 bits from a previous remote diode temperature measurement, the master must insure that all 11 bits are from the same temperature conversion. This may be achieved by reading the MSB register first. The LSB will be locked after the MSB is read. The LSB will be unlocked after being read. If the user reads MSBs consecutively, each time the MSB is read, the LSB associated with that temperature will be locked in and override the previous LSB value locked-in.

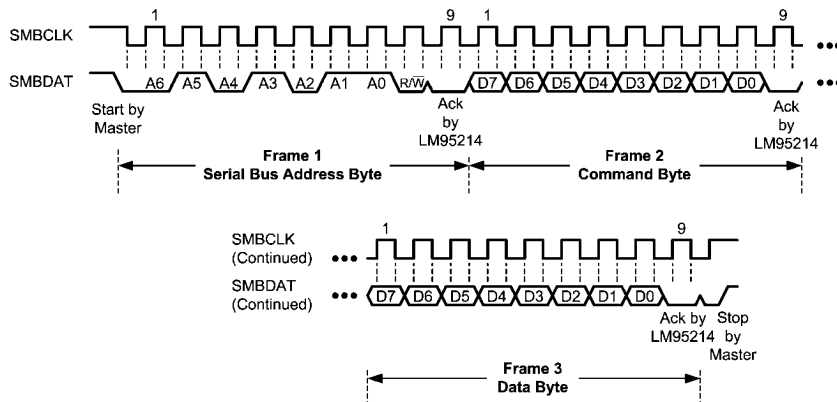

(a) Serial Bus Write to the internal Command Register followed by the Data Byte

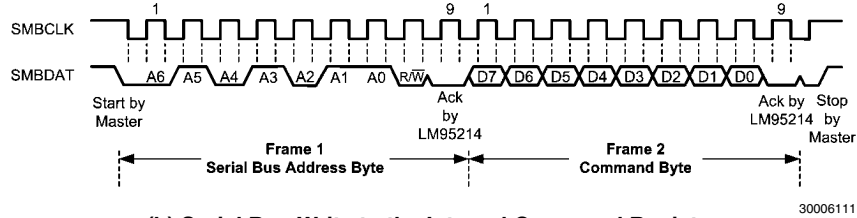

(b) Serial Bus Write to the Internal Command Register

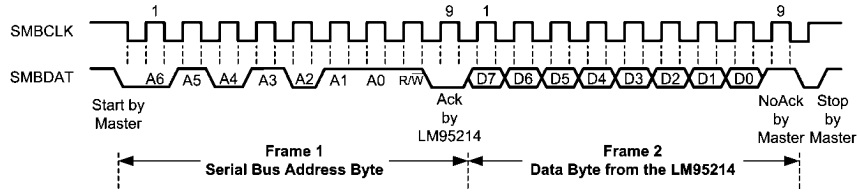

(c) Serial Bus Read from a Register with the Internal Command Register preset to desired value.

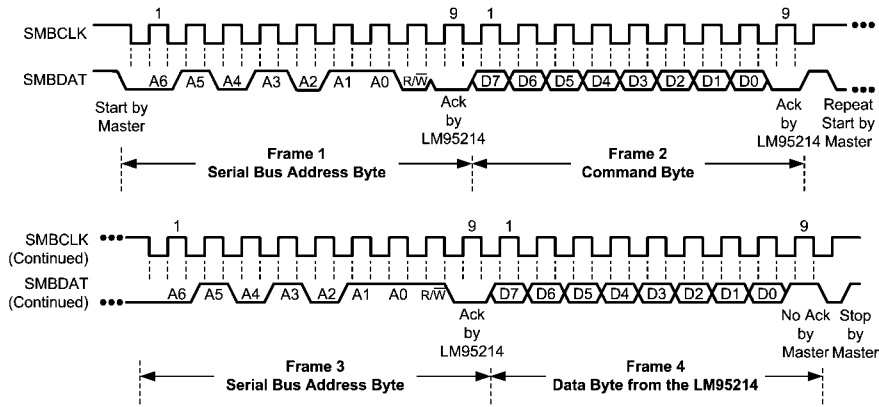

(d) Serial Bus Write followed by a Repeat Start and Immediate Read

FIGURE 8. SMBus Timing Diagrams

1.12 SERIAL INTERFACE RESET

In the event that the SMBus Master is RESET while the LM95214 is transmitting on the SMBDAT line, the LM95214 must be returned to a known state in the communication protocol. This may be done in one of two ways:

1. When SMBDAT is LOW, the LM95214 SMBus state machine resets to the SMBus idle state if either SMBDAT or SMBCLK are held low for more than 35ms ($t_{TIMEOUT}$). Note that according to SMBus specification 2.0 all devices are to timeout when either the SMBCLK or SMBDAT lines are held low for 25-35ms. Therefore, to insure a timeout of all devices on the bus the SMBCLK or SMBDAT lines must be held low for at least 35ms.
2. When SMBDAT is HIGH, have the master initiate an SMBus start. The LM95214 will respond properly to an SMBus start condition at any point during the

communication. After the start the LM95214 will expect an SMBus Address address byte.

1.13 ONE-SHOT CONVERSION

The One-Shot register is used to initiate a round of conversions and comparisons when the device is in standby mode, after which the device returns to standby. This is not a data register and it is the write operation that causes the one-shot conversion. The data written to this address is irrelevant and is not stored. A zero will always be read from this register. All the channels that are enabled in the Channel Enable Register will be converted once and the $\overline{TCRIT1}$, $\overline{TCRIT2}$ and $\overline{TCRIT3}$ pins will reflect the comparison results based on this round of conversion results of the channels that are not masked.

2.0 LM95214 Registers

Command register selects which registers will be read from or written to. Data for this register should be transmitted during the Command Byte of the SMBus write communication.

P7	P6	P5	P4	P3	P2	P1	P0
Command Byte							

P0-P7: Command

Register Summary

Register Name	Command Byte (Hex)	Read/Write	D7	D6	D5	D4	D3	D2	D1	D0	POR Default (Hex)
Local Temp MSB	0x10	RO	SIGN	64	32	16	8	4	2	1	–
Local Temp LSB	0x20	RO	1/2	1/4	1/8	0	0	0	0	0	–
Remote Temp 1 MSB – Signed	0x11	RO	SIGN	64	32	16	8	4	2	1	–
Remote Temp 1 LSB – Signed, Digital Filter Off	0x21	RO	1/2	1/4	1/8	0	0	0	0	0	–
Remote Temp 1 LSB – Signed, Digital Filter On						1/16	1/32				
Remote Temp 2 MSB – Signed	0x12	RO	SIGN	64	32	16	8	4	2	1	–
Remote Temp 2 LSB – Signed, Digital Filter Off	0x22	RO	1/2	1/4	1/8	0	0	0	0	0	–
Remote Temp 2 LSB – Signed, Digital Filter On						1/16	1/32				
Remote Temp 3 MSB – Signed	0x13	RO	SIGN	64	32	16	8	4	2	1	–
Remote Temp 3 LSB – Signed	0x23	RO	1/2	1/4	1/8	0	0	0	0	0	–
Remote Temp 4 MSB – Signed	0x14	RO	SIGN	64	32	16	8	4	2	0	–
Remote Temp 4 LSB – Signed	0x24	RO	1/2	1/4	1/8	0	0	0	0	0	–
Remote Temp 1 MSB – Unsigned	0x19	RO	128	64	32	16	8	4	2	1	–
Remote Temp 1 LSB – Unsigned, Digital Filter Off	0x29	RO	1/2	1/4	1/8	0	0	0	0	0	–
Remote Temp 1 LSB – Unsigned, Digital Filter On						1/16	1/32				
Remote Temp 2 MSB – Unsigned	0x1A	RO	128	64	32	16	8	4	2	1	–
Remote Temp 2 LSB – Unsigned, Digital Filter Off	0x2A	RO	1/2	1/4	1/8	0	0	0	0	0	–
Remote Temp 2 LSB – Unsigned, Digital Filter On						1/16	1/32				
Remote Temp 3 MSB – Unsigned	0x1B	RO	128	64	32	16	8	4	2	1	–
Remote Temp 3 LSB – Unsigned	0x2B	RO	1/2	1/4	1/8	0	0	0	0	0	–
Remote Temp 4 MSB – Unsigned	0x1C	RO	128	64	32	16	8	4	2	1	–
Remote Temp 4 LSB – Unsigned	0x2C	RO	1/2	1/4	1/8	0	0	0	0	0	–
Remote 1 Offset	0x31	R/W	SIGN	32	16	8	4	2	1	1/2	0x00
Remote 2 Offset	0x32	R/W	SIGN	32	16	8	4	2	1	1/2	0x00
Remote 3 Offset	0x33	R/W	SIGN	32	16	8	4	2	1	1/2	0x00
Remote 4 Offset	0x34	R/W	SIGN	32	16	8	4	2	1	1/2	0x00
Configuration	0x03	R/W	–	STBY	–	–	–	–	R4QE	R3QE	0x03
Conversion Rate	0x04	R/W	–	–	–	–	–	–	CR1	CR0	0x02
Channel Conversion Enable	0x05	R/W	–	–	–	R4CE	R3CE	R2CE	R1CE	LCE	0x1F
Filter Setting	0x06	R/W	–	–	–	–	R2F1	R2F0	R1F1	R1F0	0x0F
1-shot	0x0F	WO	–	–	–	–	–	–	–	–	–
Common Status Register	0x02	RO	BUSY	NR	–	–	SR4F	SR3F	SR2F	SR1F	0x00
Status 1 (Diode Fault)	0x07	RO	R4DO	R4DS	R3DO	R3DS	R2DO	R2DS	R1DO	R1DS	–
Status 2 (TCRIT1)	0x08	RO	–	–	–	R4T1	R3T1	R2T1	R1T1	LT1	–
Status 3 (TCRIT2)	0x09	RO	–	–	–	R4T2	R3T2	R2T2	R1T2	LT2	–
Status 4 (TCRIT3)	0x0A	RO	–	–	–	R4T3	R3T3	R2T3	R1T3	LT3	–

Register Name	Command Byte (Hex)	Read/Write	D7	D6	D5	D4	D3	D2	D1	D0	POR Default (Hex)
TCRIT1 Mask	0x0C	R/W	–	–	–	R4TM	R3TM	R2T1M	R1T1M	LTM	0x19
TCRIT2 Mask	0x0D	R/W	–	–	–	R4TM	R3TM	R2T2M	R1T2M	LTM	0x00
TCRIT3 Mask	0x0E	R/W	–	–	–	R4TM	R3TM	R2T2M	R1T2M	LTM	0x07
Local Tcrit Limit	0x40	R/W	0	64	32	16	8	4	2	1	0x55
Remote 1 Tcrit-1 Limit	0x41	R/W	128	64	32	16	8	4	2	1	0x6E
Remote 2 Tcrit-1 Limit	0x42	R/W	128	64	32	16	8	4	2	1	0x6E
Remote 3 Tcrit Limit	0x43	R/W	128	64	32	16	8	4	2	1	0x55
Remote 4 Tcrit Limit	0x44	R/W	128	64	32	16	8	4	2	1	0x55
Remote 1 Tcrit-2 and Tcrit-3 Limit	0x49	R/W	128	64	32	16	8	4	2	1	0x55
Remote 2 Tcrit-2 and Tcrit-3 Limit	0x4A	R/W	128	64	32	16	8	4	2	1	0x55
Common Tcrit Hysteresis	0x5A	R/W	0	0	0	16	8	4	2	1	0x0A
Manufacturer ID	0xFE	RO	0	0	0	0	0	0	0	1	0x01
Revision ID	0xFF	RO	0	1	1	1	1	0	1	1	0x7B

2.1 VALUE REGISTERS

For data synchronization purposes, the MSB register should be read first if the user wants to read both MSB and LSB registers. The LSB will be locked after the MSB is read. The LSB will be unlocked after being read. If the user reads MSBs consecutively, each time the MSB is read, the LSB associated with that temperature will be locked in and override the previous LSB value locked in.

2.1.1 Local Value Registers

Register Name	Command Byte (Hex)	Read/Write	D7	D6	D5	D4	D3	D2	D1	D0	POR Default (Hex)
Local Temp MSB	0x10	RO	SIGN	64	32	16	8	4	2	1	–
Local Temp LSB	0x20	RO	1/2	1/4	1/8	0	0	0	0	0	–

Bit(s)	Bit Name	Read/Write	Description
7	SIGN	RO	Sign bit
6	64	RO	bit weight 64°C
5	32	RO	bit weight 32°C
4	16	RO	bit weight 16°C
3	8	RO	bit weight 8°C
2	4	RO	bit weight 4°C
1	2	RO	bit weight 2°C
0	1	RO	bit weight 1°C

The Local temperature MSB value register range is +127°C to –128°C. The value programmed in this register is used to determine a local temperature error event.

Bit(s)	Bit Name	Read/Write	Description
7	1/2	RO	bit weight 1/2°C (0.5°C)
6	1/4	RO	bit weight 1/4°C (0.25°C)
5	1/8	RO	bit weight 1/8°C (0.125°C)
4-0	0	RO	Reserved – will report "0" when read.

The Local Limit register range is 0°C to 127°C. The value programmed in this register is used to determine a local temperature error event.

2.1.2 Remote Temperature Value Registers with Signed Format

Register Name	Command Byte (Hex)	Read/Write	D7	D6	D5	D4	D3	D2	D1	D0	POR Default (Hex)
Remote Temp 1 MSB – Signed	0x11	RO	SIGN	64	32	16	8	4	2	1	–
Remote Temp 1 LSB – Signed, Digital Filter Off	0x21	RO	1/2	1/8	0	0	0	0	0	0	–
Remote Temp 1 LSB – Signed, Digital Filter On					1/16	1/32					
Remote Temp 2 MSB – Signed	0x12	RO	SIGN	64	32	16	8	4	2	1	–
Remote Temp 2 LSB – Signed, Digital Filter Off	0x22	RO	1/2	1/8	0	0	0	0	0	0	–
Remote Temp 2 LSB – Signed, Digital Filter On					1/16	1/32					
Remote Temp 3 MSB – Signed	0x13	RO	SIGN	64	32	16	8	4	2	1	–
Remote Temp 3 LSB – Signed	0x23	RO	1/2	1/8	0	0	0	0	0	0	–
Remote Temp 4 MSB – Signed	0x14	RO	SIGN	64	32	16	8	4	2	0	–
Remote Temp 4 LSB – Signed	0x24	RO	1/2	1/8	0	0	0	0	0	0	–

The Local temperature MSB value register range is +127°C to –128°C. The value programmed in this register is used to determine a local temperature error event.

Bit(s)	Bit Name	Read/Write	Description
7	SIGN	RO	Sign bit
6	64	RO	bit weight 64°C
5	32	RO	bit weight 32°C
4	16	RO	bit weight 16°C
3	8	RO	bit weight 8°C
2	4	RO	bit weight 4°C
1	2	RO	bit weight 2°C
0	1	RO	bit weight 1°C

Bit(s)	Bit Name	Read/Write	Description
7	1/2	RO	bit weight 1/2°C (0.5°C)
6	1/4	RO	bit weight 1/4°C (0.25°C)
5	1/8	RO	bit weight 1/8°C (0.125°C)
4	0 or 1/16	RO	When the digital filter is disabled this bit will always read "0". When the digital filter is enabled this bit will report 1/16°C (0.0625°C) bit state.
3	0 or 1/32	RO	When the digital filter is disabled this bit will always read "0". When the digital filter is enabled this bit will report 1/32°C (0.03125°C) bit state.
2-0	0	RO	Reserved – will report "0" when read.

2.1.3 Remote Temperature Value Registers with Unsigned Format

Register Name	Command Byte (Hex)	Read/Write	D7	D6	D5	D4	D3	D2	D1	D0	POR Default (Hex)
Remote Temp 1 MSB – Unsigned	0x19	RO	128	64	32	16	8	4	2	1	–
Remote Temp 1 LSB – Unsigned, Digital Filter Off	0x29	RO	1/2	1/8	0	0	0	0	0	0	–
Remote Temp 1 LSB – Unsigned, Digital Filter On					1/16	1/32					
Remote Temp 2 MSB – Unsigned	0x1A	RO	128	64	32	16	8	4	2	1	–
Remote Temp 2 LSB – Unsigned, Digital Filter Off	0x2A	RO	1/2	1/8	0	0	0	0	0	0	–
Remote Temp 2 LSB – Unsigned, Digital Filter On					1/16	1/32					
Remote Temp 3 MSB – Unsigned	0x1B	RO	128	64	32	16	8	4	2	1	–
Remote Temp 3 LSB – Unsigned	0x2B	RO	1/2	1/8	0	0	0	0	0	0	–
Remote Temp 4 MSB – Unsigned	0x1C	RO	128	64	32	16	8	4	2	1	–
Remote Temp 4 LSB – Unsigned	0x2C	RO	1/2	1/8	0	0	0	0	0	0	–

Bit(s)	Bit Name	Read/Write	Description
7	SIGN	RO	bit weight 128°C
6	64	RO	bit weight 64°C
5	32	RO	bit weight 32°C
4	16	RO	bit weight 16°C
3	8	RO	bit weight 8°C
2	4	RO	bit weight 4°C
1	2	RO	bit weight 2°C
0	1	RO	bit weight 1°C

Bit(s)	Bit Name	Read/Write	Description
7	1/2	RO	bit weight 1/2°C (0.5°C)
6	1/4	RO	bit weight 1/4°C (0.25°C)
5	1/8	RO	bit weight 1/8°C (0.125°C)
4	0 or 1/16	RO	When the digital filter is disabled this bit will always read "0". When the digital filter is enabled this bit will report 1/16°C (0.0625°C) bit state.
3	0 or 1/32	RO	When the digital filter is disabled this bit will always read "0". When the digital filter is enabled this bit will report 1/32°C (0.03125°C) bit state.
2-0	0	RO	Reserved – will report "0" when read.

2.2 DIODE CONFIGURATION REGISTER

2.2.1 Remote 1-4 Offset

Register Name	Command Byte (Hex)	Read/Write	D7	D6	D5	D4	D3	D2	D1	D0	POR Default (Hex)
Remote 1 Offset	0x31	R/W	SIGN	32	16	8	4	2	1	1/2	0x00
Remote 2 Offset	0x32	R/W	SIGN	32	16	8	4	2	1	1/2	0x00
Remote 3 Offset	0x33	R/W	SIGN	32	16	8	4	2	1	1/2	0x00
Remote 4 Offset	0x34	R/W	SIGN	32	16	8	4	2	1	1/2	0x00

Bit(s)	Bit Name	Read/Write	Description
7	SIGN	R/W	Sign bit
6	32	R/W	bit weight 32°C
5	16	R/W	bit weight 16°C
4	8	R/W	bit weight 8°C
3	4	R/W	bit weight 4°C
2	2	R/W	bit weight 2°C
1	1	R/W	bit weight 1°C
0	1/2	R/W	bit weight 1/2°C (0.5°C)

All registers have 2's complement format. The offset range for each remote is +63.5°C/–64°C. The value programmed in this register is directly added to the actual reading of the ADC and the modified number is reported in the remote value registers.

2.3 CONFIGURATION REGISTERS

2.3.1 Main Configuration Register

Register Name	Command Byte (Hex)	Read/Write	D7	D6	D5	D4	D3	D2	D1	D0	POR Default (Hex)
Configuration	0x03	R/W	–	STBY	–	–	–	–	R4QE	R3QE	0x03

Bit(s)	Bit Name	Read/Write	Description
7	–	RO	Reserved will report "0" when read.
6	STBY	R/W	Software Standby 1 – standby (when in this mode one conversion sequence can be initiated by writing to the one-shot register) 0 – active/converting
5–2	–	RO	Reserved – will report "0" when read.
1	R4QE	R/W	Fault queue enable for Remote 4 1– Fault queue enabled 0– Fault queue disabled
0	R3QE	R/W	Fault queue enable for Remote 3 1– Fault queue enabled 0– Fault queue disabled

2.3.2 Conversion Rate Register

Register Name	Command Byte (Hex)	Read/Write	D7	D6	D5	D4	D3	D2	D1	D0	POR Default (Hex)
Conversion Rate	0x04	R/W	–	–	–	–	–	–	CR1	CR0	0x02

Bit(s)	Bit Name	Read/Write	Description	
7-2	–	RO	Reserved – will report "0" when read.	
1-0	CR[1:0]	R/W	Conversion rate control bits modify the time interval for conversion of the channels enabled. The channels enabled are converted sequentially then standby mode enabled for the remainder of the time interval.	
			CR[1:0]	Conversion Rate
			00	continuous (30 ms to 143 ms)
			01	0.364 s
			10	1s
			11	2.5 s

2.3.3 Channel Conversion Enable

When a conversion is disabled for a particular channel it is skipped. The continuous conversion rate is effected all other conversion rates are not effected as extra standby time is inserted in order to compensate. See Conversion Rate Register description.

Register Name	Command Byte (Hex)	Read/Write	D7	D6	D5	D4	D3	D2	D1	D0	POR Default (Hex)
Channel Conversion Enable	0x05	R/W	–	–	–	R4CE	R3CE	R2CE	R1CE	LCE	0x1F

Bit(s)	Bit Name	Read/Write	Description
7–5	–	RO	Reserved – will report "0" when read.
4	R4CE	R/W	Remote 4 Temperature Conversion Enable 1– Remote 4 temp conversion enabled 0– Remote 4 temp conversion disabled
3	R3CE	R/W	Remote 3 Temperature Conversion Enable 1– Remote 3 temp conversion enabled 0– Remote 3 temp conversion disabled
2	R2CE	R/W	Remote 2 Temperature Conversion Enable 1– Remote 2 temp conversion enabled 0– Remote 2 temp conversion disabled
1	R1CE	R/W	Remote 1 Temperature Conversion Enable 1– Remote 1 temp conversion enabled 0– Remote 1 temp conversion disabled
0	LCE	R/W	Local Temperature Conversion Enable 1– Local temp conversion enabled 0– Local temp conversion disabled

2.3.4 Filter Setting

Register Name	Command Byte (Hex)	Read/Write	D7	D6	D5	D4	D3	D2	D1	D0	POR Default (Hex)
Filter Setting	0x06	R/W	–	–	–	–	R2F1	R2F0	R1F1	R1F0	0x0F

Bit(s)	Bit Name	Read/Write	Description	
7–4	–	RO	Reserved – will report "0" when read.	
3–2	R2F[1:0]	R/W	Remote Channel 2 Filter Enable Bits	
			R2F[1:0]	Digital Filter State
			00	disable all digital filtering
			01	enable basic filter
			10	reserved (do not use)
	11	enable enhanced filter		
1–0	R1F[1:0]	R/W	Remote Channel 1 Filter Enable	
			R1F[1:0]	Filter State
			00	disable all digital filtering
			01	enable basic filter
			10	reserved (do not use)
	11	enable enhanced filter		

2.3.5 1-Shot

Register Name	Command Byte (Hex)	Read/Write	D7	D6	D5	D4	D3	D2	D1	D0	POR Default (Hex)
1-Shot	0x0F	WO	–	–	–	–	–	–	–	–	–

Bit(s)	Bit Name	Read/Write	Description
7–0	–	WO	Writing to this register activates one conversion for all the enabled channels if the chip is in standby mode (i.e. standby bit = 1). The actual data written does not matter and is not stored.

2.4 STATUS REGISTERS

2.4.1 Common Status Register

Register Name	Command Byte (Hex)	Read/Write	D7	D6	D5	D4	D3	D2	D1	D0	POR Default (Hex)
Common Status Register	0x02	RO	BUSY	NR	–	–	SR4F	SR3F	SR2F	SR1F	0x00

Bit(s)	Bit Name	Read/Write	Description
7	BUSY	RO	Busy bit (device converting)
6	NR	RO	Not Ready bit (30 ms), indicates power up initialization sequence is in progress
5–4	–	RO	Reserved – will report "0" when read.
3	SR4F	RO	Status Register 4 Flag: 1 – indicates that Status Register 4 has at least one bit set 0 – indicates that all of Status Register 4 bits are cleared
2	SR3F	RO	Status Register 3 Flag: 1 – indicates that Status Register 3 has at least one bit set 0 – indicates that all of Status Register 3 bits are cleared

Bit(s)	Bit Name	Read/Write	Description
1	SR2F	RO	Status Register 2 Flag: 1 – indicates that Status Register 2 has at least one bit set 0 – indicates that all of Status Register 2 bits are cleared
0	SR1F	RO	Status Register 1 Flag: 1 – indicates that Status Register 1 has at least one bit set 0 – indicates that all of Status Register 1 bits are cleared

2.4.2 Status 1 Register (Diode Fault)

Status fault bits for open or shorted diode (i.e. Short Fault: D+ shorted to Ground or D-; Open Fault: D+ shorted to V_{DD} , or floating). During fault conditions the temperature reading is 0 °C if unsigned value registers are read or -128.000 °C if signed value registers are read.

Register Name	Command Byte (Hex)	Read/Write	D7	D6	D5	D4	D3	D2	D1	D0	POR Default (Hex)
Status 1 (Diode Fault)	0x07	RO	R4DO	R4DS	R3DO	R3DS	R2DO	R2DS	R1DO	R1DS	–

Bit(s)	Bit Name	Read/Write	Description
7	R4DO	RO	Remote 4 diode open fault status: 1 – indicates that remote 4 diode has an "open" fault 0 – indicates that remote 4 diode does not have an "open" fault
6	R4DS	RO	Remote 4 diode short fault status: 1 – indicates that remote 4 diode has a "short" fault 0 – indicates that remote 4 diode does not have a "short" fault
5	R3DO	RO	Remote 3 diode open fault status: 1 – indicates that remote 3 diode has an "open" fault 0 – indicates that remote 3 diode does not have an "open" fault
4	R3DS	RO	Remote 3 diode short fault status: 1 – indicates that remote 3 diode has a "short" fault 0 – indicates that remote 3 diode does not have a "short" fault
3	R2DO	RO	Remote 2 diode open fault status: 1 – indicates that remote 2 diode has an "open" fault 0 – indicates that remote 2 diode does not have an "open" fault
2	R2DS	RO	Remote 2 diode short fault status: 1 – indicates that remote 2 diode has a "short" fault 0 – indicates that remote 2 diode does not have a "short" fault
1	R1DO	RO	Remote 1 diode open fault status: 1 – indicates that remote 1 diode has an "open" fault 0 – indicates that remote 1 diode does not have an "open" fault
0	R1DS	RO	Remote 1 diode short fault status: 1 – indicates that remote 1 diode has a "short" fault 0 – indicates that remote 1 diode does not have a "short" fault

2.4.3 Status 2 ($\overline{\text{TCRIT1}}$)

Status bits for $\overline{\text{TCRIT1}}$. When one or more of these bits are set and if not masked the $\overline{\text{TCRIT1}}$ output will activate. $\overline{\text{TCRIT1}}$ will deactivate when all these bits are cleared.

Register Name	Command Byte (Hex)	Read/Write	D7	D6	D5	D4	D3	D2	D1	D0	POR Default (Hex)
Status 2 ($\overline{\text{TCRIT1}}$)	0x08	RO	-	-	-	R4T1	R3T1	R2T1	R1T1	LT1	-

Bit(s)	Bit Name	Read/Write	Description
7-5	-	RO	Reserved – will report "0" when read.
4	R4T1	RO	Remote 4 Tcrit Status: 1 – indicates that remote 4 reading is greater than or equal to the value set in Remote 4 Tcrit Limit register 0 – indicates that that remote 4 reading is less than the value set in Remote 4 Tcrit Limit register minus the Common Hysteresis value
3	R3T1	RO	Remote 3 Tcrit Status: 1 – indicates that remote 3 reading is greater than or equal to the value set in Remote 3 Tcrit Limit register 0 – indicates that that remote 3 reading is less than the value set in Remote 3 Tcrit Limit register minus the Common Hysteresis value
2	R2T1	RO	Remote 2 Tcrit-1 Status: 1 – indicates that remote 2 reading is greater than or equal to the value set in Remote 2 Tcrit-1 Limit register 0 – indicates that that remote 2 reading is less than the value set in Remote 2 Tcrit-1 Limit register minus the Common Hysteresis value
1	R1T1	RO	Remote 1 Tcrit-1 Status: 1 – indicates that remote 1 reading is greater than or equal to the value set in Remote 1 Tcrit-1 Limit register 0 – indicates that that remote 1 reading is less than the value set in Remote 1 Tcrit-1 Limit register minus the Common Hysteresis value
0	LT1	RO	Local Tcrit Status: 1 – indicates that local reading is greater than or equal to the value set in Local Tcrit Limit register 0 – indicates that local reading is less than the value set in Local Tcrit Limit register minus the Common Hysteresis value

2.4.4 Status 3 ($\overline{\text{TCRIT2}}$)

Status bits for $\overline{\text{TCRIT2}}$. When one or more of these bits are set and if not masked the $\overline{\text{TCRIT2}}$ output will activate. $\overline{\text{TCRIT2}}$ will deactivate when all these bits are cleared.

Register Name	Command Byte (Hex)	Read/Write	D7	D6	D5	D4	D3	D2	D1	D0	POR Default (Hex)
Status 3 ($\overline{\text{TCRIT2}}$)	0x09	RO	-	-	-	R4T2	R3T2	R2T2	R1T2	LT2	-

Bit(s)	Bit Name	Read/Write	Description
7-5	-	RO	Reserved – will report "0" when read.
4	R4T2	RO	Remote 4 Tcrit Status: 1 – indicates that remote 4 reading is greater than or equal to the value set in Remote 4 Tcrit Limit register 0 – indicates that that remote 4 reading is less than the value set in Remote 4 Tcrit Limit register minus the Common Hysteresis value
3	R3T2	RO	Remote 3 Tcrit Status: 1 – indicates that remote 3 reading is greater than or equal to the value set in Remote 3 Tcrit Limit register 0 – indicates that that remote 3 reading is less than the value set in Remote 3 Tcrit Limit register minus the Common Hysteresis value
2	R2T2	RO	Remote 2 Tcrit-2 Status: 1 – indicates that remote 2 reading is greater than or equal to the value set in Remote 2 Tcrit-2 Limit register 0 – indicates that that remote 2 reading is less than the value set in Remote 2 Tcrit-2 Limit register minus the Common Hysteresis value
1	R1T2	RO	Remote 1 Tcrit-2 Status: 1 – indicates that remote 1 reading is greater than or equal to the value set in Remote 1 Tcrit-2 Limit register 0 – indicates that that remote 1 reading is less than the value set in Remote 1 Tcrit-2 Limit register minus the Common Hysteresis value
0	LT2	RO	Local Tcrit Status: 1 – indicates that local reading is greater than or equal to the value set in Local Tcrit Limit register 0 – indicates that local reading is less than the value set in Local Tcrit Limit register minus the Common Hysteresis value

2.4.5 Status 4 ($\overline{\text{TCRIT3}}$)

Status bits for $\overline{\text{TCRIT3}}$. When one or more of these bits are set and if not masked the $\overline{\text{TCRIT3}}$ output will activate. $\overline{\text{TCRIT3}}$ will deactivate when all these bits are cleared.

Register Name	Command Byte (Hex)	Read/Write	D7	D6	D5	D4	D3	D2	D1	D0	POR Default (Hex)
Status 4 ($\overline{\text{TCRIT3}}$)	0x0A	RO	-	-	-	R4T3	R3T3	R2T3	R1T3	LT3	-

Bit(s)	Bit Name	Read/Write	Description
7-5	-	RO	Reserved – will report "0" when read.
4	R4T3	RO	Remote 4 Tcrit Status: 1 – indicates that remote 4 reading is greater than or equal to the value set in Remote 4 Tcrit Limit register 0 – indicates that that remote 4 reading is less than the value set in Remote 4 Tcrit Limit register minus the Common Hysteresis value
3	R3T3	RO	Remote 3 Tcrit Status: 1 – indicates that remote 3 reading is greater than or equal to the value set in Remote 3 Tcrit Limit register 0 – indicates that that remote 3 reading is less than the value set in Remote 3 Tcrit Limit register minus the Common Hysteresis value
2	R2T3	RO	Remote 2 Tcrit-2 Status: 1 – indicates that remote 2 reading is greater than or equal to the value set in Remote 2 Tcrit-2 Limit register 0 – indicates that that remote 2 reading is less than the value set in Remote 2 Tcrit-2 Limit register minus the Common Hysteresis value
1	R1T3	RO	Remote 1 Tcrit-2 Status: 1 – indicates that remote 1 reading is greater than or equal to the value set in Remote 1 Tcrit-2 Limit register 0 – indicates that that remote 1 reading is less than the value set in Remote 1 Tcrit-2 Limit register minus the Common Hysteresis value
0	LT3	RO	Local Tcrit Status: 1 – indicates that local reading is greater than or equal to the value set in Local Tcrit Limit register 0 – indicates that local reading is less than the value set in Local Tcrit Limit register minus the Common Hysteresis value

2.5 MASK REGISTERS

2.5.1 TCRIT1 Mask Register

The mask bits in this register allow control over which error events propagate to the $\overline{\text{TCRIT1}}$ pin.

Register Name	Command Byte (Hex)	Read/Write	D7	D6	D5	D4	D3	D2	D1	D0	POR Default (Hex)
$\overline{\text{TCRIT1}}$ Mask	0x0C	R/W	–	–	–	R4TM	R3TM	R2T1 M	R1T1 M	LTM	0x19

Bit(s)	Bit Name	Read/Write	Description
7-5	–	RO	Reserved – will report "0" when read.
4	R4TM	R/W	Remote 4 Tcrit Mask: 1 – prevents the remote 4 temperature error event from propagating to the $\overline{\text{TCRIT1}}$ pin 0 – allows the remote 4 temperature error event to propagate to the $\overline{\text{TCRIT1}}$ pin
3	R3TM	R/W	Remote 3 Tcrit Mask: 1 – prevents the remote 3 temperature error event from propagating to the $\overline{\text{TCRIT1}}$ pin 0 – allows the remote 3 temperature error event to propagate to the $\overline{\text{TCRIT1}}$ pin
2	R2T1M	R/W	Remote 2 Tcrit-1 Mask: 1 – prevents the remote 2 temperature error event from propagating to the $\overline{\text{TCRIT1}}$ pin 0 – allows the remote 2 temperature error event to propagate to the $\overline{\text{TCRIT1}}$ pin
1	R1T1M	R/W	Remote 1 Tcrit-1 Mask: 1 – prevents the remote 1 temperature error event from propagating to the $\overline{\text{TCRIT1}}$ pin 0 – allows the remote 1 temperature error event to propagate to the $\overline{\text{TCRIT1}}$ pin
0	LTM	R/W	Local Tcrit Mask: 1 – prevents the local temperature error event from propagating to the $\overline{\text{TCRIT1}}$ pin 0 – allows the local temperature error event to propagate to the $\overline{\text{TCRIT1}}$ pin

2.5.2 $\overline{\text{TCRIT2}}$ Mask Registers

Register Name	Command Byte (Hex)	Read/Write	D7	D6	D5	D4	D3	D2	D1	D0	POR Default (Hex)
$\overline{\text{TCRIT2}}$ Mask	0x0D	R/W	–	–	–	R4TM	R3TM	R2T2 M	R1T2 M	LTM	0x00

Bit(s)	Bit Name	Read/Write	Description
7-5	–	RO	Reserved – will report "0" when read.
4	R4TM	R/W	Remote 4 Tcrit Mask: 1 – prevents the remote 4 temperature error event from propagating to the $\overline{\text{TCRIT2}}$ pin 0 – allows the remote 4 temperature error event to propagate to the $\overline{\text{TCRIT2}}$ pin
3	R3TM	R/W	Remote 3 Tcrit Mask: 1 – prevents the remote 3 temperature error event from propagating to the $\overline{\text{TCRIT2}}$ pin 0 – allows the remote 3 temperature error event to propagate to the $\overline{\text{TCRIT2}}$ pin
2	R2T2M	R/W	Remote 2 Tcrit-2 Mask: 1 – prevents the remote 2 temperature error event from propagating to the $\overline{\text{TCRIT2}}$ pin 0 – allows the remote 2 temperature error event to propagate to the $\overline{\text{TCRIT2}}$ pin
1	R1T2M	R/W	Remote 1 Tcrit-2 Mask: 1 – prevents the remote 1 temperature error event from propagating to the $\overline{\text{TCRIT2}}$ pin 0 – allows the remote 1 temperature error event to propagate to the $\overline{\text{TCRIT2}}$ pin
0	LTM	R/W	Local Tcrit Mask: 1 – prevents the local temperature error event from propagating to the $\overline{\text{TCRIT2}}$ pin 0 – allows the local temperature error event to propagate to the $\overline{\text{TCRIT2}}$ pin

2.5.3 $\overline{\text{TCRIT3}}$ Mask Register

The mask bits in this register allow control over which error events propagate to the $\overline{\text{TCRIT3}}$ pin.

Register Name	Command Byte (Hex)	Read/Write	D7	D6	D5	D4	D3	D2	D1	D0	POR Default (Hex)
$\overline{\text{TCRIT3}}$ Mask	0x0E	R/W	–	–	–	R4TM	R3TM	R2T2M	R1T2M	LTM	0x07

Bit(s)	Bit Name	Read/Write	Description
7-5	–	RO	Reserved – will report "0" when read.
4	R4TM	R/W	Remote 4 Tcrit Mask: 1 – prevents the remote 4 temperature error event from propagating to the $\overline{\text{TCRIT3}}$ pin 0 – allows the remote 4 temperature error event to propagate to the $\overline{\text{TCRIT3}}$ pin
3	R3TM	R/W	Remote 3 Tcrit Mask: 1 – prevents the remote 3 temperature error event from propagating to the $\overline{\text{TCRIT3}}$ pin 0 – allows the remote 3 temperature error event to propagate to the $\overline{\text{TCRIT3}}$ pin
2	R2T2M	R/W	Remote 2 Tcrit-2 Mask: 1 – prevents the remote 2 temperature error event from propagating to the $\overline{\text{TCRIT3}}$ pin 0 – allows the remote 2 temperature error event to propagate to the $\overline{\text{TCRIT3}}$ pin
1	R1T2M	R/W	Remote 1 Tcrit-2 Mask: 1 – prevents the remote 1 temperature error event from propagating to the $\overline{\text{TCRIT3}}$ pin 0 – allows the remote 1 temperature error event to propagate to the $\overline{\text{TCRIT3}}$ pin
0	LTM	R/W	Local Tcrit Mask: 1 – prevents the local temperature error event from propagating to the $\overline{\text{TCRIT3}}$ pin 0 – allows the local temperature error event to propagate to the $\overline{\text{TCRIT3}}$ pin

2.6 LIMIT REGISTERS

2.6.1 Local Limit Register

The Local Limit register range is 0°C to 127°C. The value programmed in this register is used to determine a local temperature error event.

Register Name	Command Byte (Hex)	Read/Write	D7	D6	D5	D4	D3	D2	D1	D0	POR Default (Hex)
Local Tcrit Limit	0x40	R/W	0	64	32	16	8	4	2	1	0x55

Bit(s)	Bit Name	Read/Write	Description
7	0	RO	Read only bit will always report "0".
6	64	R/W	bit weight 64°C
5	32	R/W	bit weight 32°C
4	16	R/W	bit weight 16°C
3	8	R/W	bit weight 8°C
2	4	R/W	bit weight 4°C
1	2	R/W	bit weight 2°C
0	1	R/W	bit weight 1°C

2.6.2 Remote Limit Registers

The range for these registers is 0°C to 255°C.

Register Name	Command Byte (Hex)	Read/Write	D7	D6	D5	D4	D3	D2	D1	D0	POR Default (Hex)
Remote 1 Tcrit-1 Limit (used by $\overline{\text{TCRIT1}}$ error events)	0x41	R/W	128	64	32	16	8	4	2	1	0x6E
Remote 2 Tcrit-1 Limit (used by $\overline{\text{TCRIT1}}$ error events)	0x42	R/W	128	64	32	16	8	4	2	1	0x6E
Remote 3 Tcrit Limit (used by $\overline{\text{TCRIT1}}$, $\overline{\text{TCRIT2}}$ and $\overline{\text{TCRIT3}}$ error events)	0x43	R/W	128	64	32	16	8	4	2	1	0x55
Remote 4 Tcrit Limit (used by $\overline{\text{TCRIT1}}$, $\overline{\text{TCRIT2}}$ and $\overline{\text{TCRIT3}}$ error events)	0x44	R/W	128	64	32	16	8	4	2	1	0x55
Remote 1 Tcrit-2 and Tcrit3 Limit (used by $\overline{\text{TCRIT2}}$ and $\overline{\text{TCRIT3}}$ error events)	0x49	R/W	128	64	32	16	8	4	2	1	0x55
Remote 2 Tcrit-2 and Tcrit3 Limit (used by $\overline{\text{TCRIT2}}$ and $\overline{\text{TCRIT3}}$ error events)	0x4A	R/W	128	64	32	16	8	4	2	1	0x55

Bit(s)	Bit Name	Read/Write	Description
7	128	R/W	bit weight 128°C
6	64	R/W	bit weight 64°C
5	32	R/W	bit weight 32°C
4	16	R/W	bit weight 16°C
3	8	R/W	bit weight 8°C
2	4	R/W	bit weight 4°C
1	2	R/W	bit weight 2°C
0	1	R/W	bit weight 1°C

Limit assignments for each $\overline{\text{TCRIT}}$ output pin:

Output Pin	Remote 4	Remote 3	Remote 2	Remote 1	Local
$\overline{\text{TCRIT1}}$	Remote 4 Tcrit Limit	Remote 3 Tcrit Limit	Remote 2 Tcrit-1 Limit	Remote 1 Tcrit-1 Limit	Local Tcrit Limit
$\overline{\text{TCRIT2}}$	Remote 4 Tcrit Limit	Remote 3 Tcrit Limit	Remote 2 Tcrit-2 Limit	Remote 1 Tcrit-2 Limit	Local Tcrit Limit
$\overline{\text{TCRIT3}}$	Remote 4 Tcrit Limit	Remote 3 Tcrit Limit	Remote 2 Tcrit-2 Limit	Remote 1 Tcrit-2 Limit	Local Tcrit Limit

2.6.3 Common Tcrit Hysteresis Register

The hysteresis register range is 0°C to 32°C. The value programmed in this register is used to modify all the limit values for decreasing temperature.

Register Name	Command Byte (Hex)	Read/Write	D7	D6	D5	D4	D3	D2	D1	D0	POR Default (Hex)
Common Tcrit Hysteresis	0x5A	R/W	0	0	0	16	8	4	2	1	0x0A

Bit(s)	Bit Name	Read/Write	Description
7	0	RO	Read only bit will always report "0".
6	0	RO	Read only bit will always report "0".
5	0	RO	Read only bit will always report "0".
4	16	R/W	bit weight 16°C
3	8	R/W	bit weight 8°C
2	4	R/W	bit weight 4°C

Bit(s)	Bit Name	Read/Write	Description
1	2	R/W	bit weight 2°C
0	1	R/W	bit weight 1°C

2.7 IDENTIFICATION REGISTERS

Register Name	Command Byte (Hex)	Read/Write	D7	D6	D5	D4	D3	D2	D1	D0	POR Default (Hex)
Manufacturer ID	0xFE	RO	0	0	0	0	0	0	0	1	0x01
Revision ID	0xFF	RO	0	1	1	1	1	0	1	1	0x7B

3.0 Applications Hints

The LM95214 can be applied easily in the same way as other integrated-circuit temperature sensors, and its remote diode sensing capability allows it to be used in new ways as well. It can be soldered to a printed circuit board, and because the path of best thermal conductivity is between the die and the pins, its temperature will effectively be that of the printed circuit board lands and traces soldered to the LM95214's pins. This presumes that the ambient air temperature is almost the same as the surface temperature of the printed circuit board; if the air temperature is much higher or lower than the surface temperature, the actual temperature of the LM95214 die will be at an intermediate temperature between the surface and air temperatures. Again, the primary thermal conduction path is through the leads, so the circuit board temperature will contribute to the die temperature much more strongly than will the air temperature.

To measure temperature external to the LM95214's die, incorporates remote diode sensing technology. This diode can be located on the die of a target IC, allowing measurement of the IC's temperature, independent of the LM95214's temperature. A discrete diode can also be used to sense the temperature of external objects or ambient air. Remember that a discrete diode's temperature will be affected, and often dominated, by the temperature of its leads. Most silicon diodes do not lend themselves well to this application. It is recommended that an MMBT3904 transistor base emitter junction be used with the collector tied to the base.

The LM95214 can measure a diode-connected transistor such as the MMBT3904 or the thermal diode found in an AMD processor. The LM95214 has been optimized to measure the MMBT3904 remote thermal diode the offset register can be used to calibrate for other thermal diodes easily. The LM95214 does not include TruTherm™ technology that allows sensing of sub-micron geometry process thermal diodes. For this application the LM95234 would be better suited.

The LM95234 has been specifically optimized to measure the remote thermal diode integrated in a typical Intel processor on 65 nm or 90 nm process or an MMBT3904 transistor. Using the Remote Diode Model Select register found in the LM95234 any of the four remote inputs can be optimized for a typical Intel processor on 65 nm or 90 nm process or an MMBT3904.

3.1 DIODE NON-IDEALITY

3.1.1 Diode Non-Ideality Factor Effect on Accuracy

When a transistor is connected as a diode, the following relationship holds for variables V_{BE} , T and I_F :

$$I_F = I_S \times \left[e^{\left(\frac{V_{BE}}{\eta \times V_t}\right)} - 1 \right] \quad (1)$$

where:

$$V_t = \frac{kT}{q}$$

- $q = 1.6 \times 10^{-19}$ Coulombs (the electron charge),
- T = Absolute Temperature in Kelvin
- $k = 1.38 \times 10^{-23}$ joules/K (Boltzmann's constant),
- η is the non-ideality factor of the process the diode is manufactured on,
- I_S = Saturation Current and is process dependent,
- I_F = Forward Current through the base-emitter junction
- V_{BE} = Base-Emitter Voltage drop

In the active region, the -1 term is negligible and may be eliminated, yielding the following equation

$$I_F = I_S \times \left[e^{\left(\frac{V_{BE}}{\eta \times V_t}\right)} \right] \quad (2)$$

In *Equation 2*, η and I_S are dependant upon the process that was used in the fabrication of the particular diode. By forcing two currents with a very controlled ratio (I_{F2} / I_{F1}) and measuring the resulting voltage difference, it is possible to eliminate the I_S term. Solving for the forward voltage difference yields the relationship:

$$\Delta V_{BE} = \eta \times \left(\frac{kT}{q}\right) \times \ln\left(\frac{I_{F2}}{I_{F1}}\right) \quad (3)$$

Solving *Equation 3* for temperature yields:

$$T = \frac{q \times \Delta V_{BE}}{\eta \times k \times \ln\left(\frac{I_{F2}}{I_{F1}}\right)} \quad (4)$$

Equation 4 holds true when a diode connected transistor such as the MMBT3904 is used. When this "diode" equation is applied to an integrated diode such as a processor transistor with its collector tied to GND as shown in *Figure 9* it will yield a wide non-ideality spread. This wide non-ideality spread is not due to true process variation but due to the fact that *Equation 4* is an approximation.

National invented TruTherm beta cancellation technology that uses the transistor equation, *Equation 5*, which is a more accurate representation of the topology of the thermal diode found in some sub-micron FPGAs or processors.

$$T = \frac{q \times \Delta V_{BE}}{\eta \times k \times \ln\left(\frac{I_{C2}}{I_{C1}}\right)} \quad (5)$$

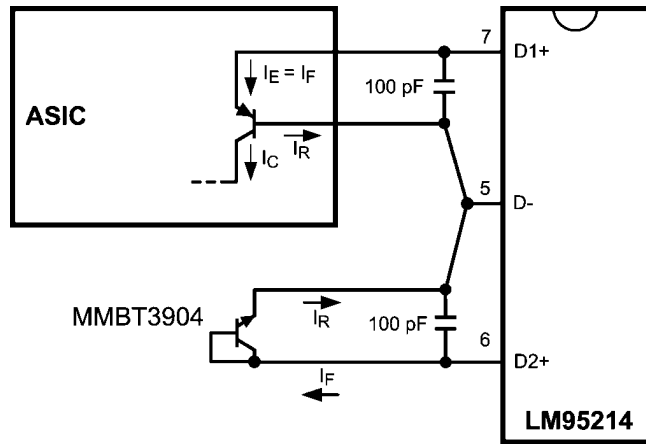

30006115

FIGURE 9. Thermal Diode Current Paths

TruTherm technology can be found in the LM95234 four channel remote diode sensor that is pin and register compatible with the LM95214. The LM95214 does not support this technology.

3.1.2 Calculating Total System Accuracy

The voltage seen by the LM95214 also includes the $I_F R_S$ voltage drop of the series resistance. The non-ideality factor, η , is the only other parameter not accounted for and depends on the diode that is used for measurement. Since ΔV_{BE} is proportional to both η and T , the variations in η cannot be distinguished from variations in temperature. Since the non-ideality factor is not controlled by the temperature sensor, it will directly add to the inaccuracy of the sensor. For the Intel processor on 65 nm process, Intel specifies a +4.06%/–0.897% variation in η from part to part when the processor diode is measured by a circuit that assumes diode equation, Equation 4, as true. As an example, assume a temperature sensor has an accuracy specification of $\pm 1.0^\circ\text{C}$ at a temperature of 80°C (353 Kelvin) and the processor diode has a non-ideality variation of +1.19%/–0.27%. The resulting system accuracy of the processor temperature being sensed will be:

$$T_{ACC} = + 1.0^\circ\text{C} + (+4.06\% \text{ of } 353 \text{ K}) = +15.3^\circ\text{C}$$

and

$$T_{ACC} = - 1.0^\circ\text{C} + (-0.89\% \text{ of } 353 \text{ K}) = -4.1^\circ\text{C}$$

The next error term to be discussed is that due to the series resistance of the thermal diode and printed circuit board traces. The thermal diode series resistance is specified on most processor data sheets. For the MMBT3904 transistor, this is specified at 0Ω typical. The LM95214 accommodates the typical series resistance of a circuit with the offset register compensation. The error that is not accounted for is the spread of the thermal diodes series resistance. If a circuit has a series resistance spread that is 2.79Ω to 6.24Ω or $4.515\Omega \pm 1.73\Omega$, the 4.515Ω can be cancelled out with the offset register setting. The $\pm 1.73\Omega$ spread cannot be cancelled out. The equation to calculate the temperature error due to series resistance (T_{ER}) for the LM95214 is simply:

$$T_{ER} = \left(0.62 \frac{^\circ\text{C}}{\Omega} \right) \times R_{PCB} \tag{6}$$

Solving Equation 6 for R_{PCB} equal to $\pm 1.73\Omega$ results in the additional error due to the spread in the series resistance of $\pm 1.07^\circ\text{C}$. The bulk of the error caused by the 4.515 ohms will cause a positive offset in the temperature reading of 2.79°C which can be cancelled out by setting the offset register to $- 2.75^\circ\text{C}$. The spread in error cannot be canceled out, as it would require measuring each individual thermal diode device. This is quite difficult and impractical in a large volume production environment.

Equation 6 can also be used to calculate the additional error caused by series resistance on the printed circuit board. Since the variation of the PCB series resistance is minimal, the bulk of the error term is always positive and can simply be cancelled out by subtracting it from the output readings of the LM95214.

Processor Family	Diode Equation η_D , non-ideality			Series R_s, Ω
	min	typ	max	
Pentium™ III CPUID 67h	1	1.0065	1.0125	
Pentium III CPUID 68h/PGA370Socket/Celeron	1.0057	1.008	1.0125	
Pentium 4, 423 pin	0.9933	1.0045	1.0368	
Pentium 4, 478 pin	0.9933	1.0045	1.0368	
Pentium 4 on 0.13 micron process, 2 - 3.06 GHz	1.0011	1.0021	1.0030	3.64
Pentium 4 on 90 nm process	1.0083	1.011	1.023	3.33
Intel Processor on 65 nm process	1.000	1.009	1.050	4.52
Pentium M (Centrino)	1.00151	1.00220	1.00289	3.06
MMBT3904		1.003		
AMD Athlon MP model 6	1.002	1.008	1.016	
AMD Athlon 64	1.008	1.008	1.096	

AMD Opteron	1.008	1.008	1.096	
AMD Sempron		1.00261		0.93

3.1.3 Compensating for Different Non-Ideality

In order to compensate for the errors introduced by non-ideality, the temperature sensor is calibrated for a particular processor. National Semiconductor temperature sensors are always calibrated to the typical non-ideality and series resistance of a given transistor type. The LM95214 is calibrated for the non-ideality factor and series resistance values of the MMBT3904 transistor without the requirement for additional trims. When a temperature sensor calibrated for a particular thermal diode type is used with a different thermal diode type, additional errors are introduced.

Temperature errors associated with non-ideality of different processor types may be reduced in a specific temperature range of concern through use of software calibration. Typical Non-ideality specification differences cause a gain variation of the transfer function, therefore the center of the temperature range of interest should be the target temperature for calibration purposes. The following equation can be used to calculate the temperature correction factor (T_{CF}) required to compensate for a target non-ideality differing from that supported by the LM95214.

$$T_{CF} = \left(\frac{\eta_S - \eta_{\text{PROCESSOR}}}{\eta_S} \right) \times (T_{CR} + 273K) \quad (7)$$

where

- η_S = LM95214 non-ideality for accuracy specification
- $\eta_{\text{PROCESSOR}}$ = Processor thermal diode typical non-ideality
- T_{CR} = center of the temperature range of interest in °C

The correction factor should be directly added to the temperature reading produced by the LM95214. For example when using the LM95214, with the 3904 mode selected, to measure a AMD Athlon processor, with a typical non-ideality of 1.008, for a temperature range of 60 °C to 100 °C the correction factor would calculate to:

$$T_{CF} = \left(\frac{1.003 - 1.008}{1.003} \right) \cdot (80 + 273) = -1.75^\circ\text{C} \quad (8)$$

Therefore, 1.75°C should be subtracted from the temperature readings of the LM95214 to compensate for the differing typical non-ideality target.

3.2 PCB LAYOUT FOR MINIMIZING NOISE

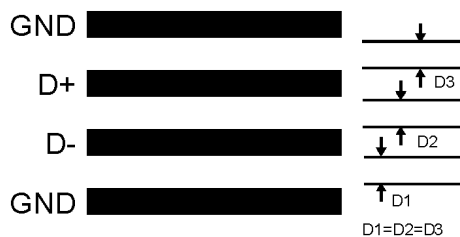

30006117

FIGURE 10. Ideal Diode Trace Layout

In a noisy environment, such as a processor mother board, layout considerations are very critical. Noise induced on

traces running between the remote temperature diode sensor and the LM95214 can cause temperature conversion errors. Keep in mind that the signal level the LM95214 is trying to measure is in microvolts. The following guidelines should be followed:

1. V_{DD} should be bypassed with a 0.1 μF capacitor in parallel with 100 pF. The 100 pF capacitor should be placed as close as possible to the power supply pin. A bulk capacitance of approximately 10 μF needs to be in the near vicinity of the LM95214.
2. A 100 pF diode bypass capacitor is recommended to filter high frequency noise but may not be necessary. Make sure the traces to the 100 pF capacitor are matched. Place the filter capacitors close to the LM95214 pins.
3. Ideally, the LM95214 should be placed within 10 cm of the Processor diode pins with the traces being as straight, short and identical as possible. Trace resistance of 1 Ω can cause as much as 0.62°C of error. This error can be compensated by using simple software offset compensation.
4. Diode traces should be surrounded by a GND guard ring to either side, above and below if possible. This GND guard should not be between the D+ and D- lines. In the event that noise does couple to the diode lines it would be ideal if it is coupled common mode. That is equally to the D+ and D- lines.
5. Avoid routing diode traces in close proximity to power supply switching or filtering inductors.
6. Avoid running diode traces close to or parallel to high speed digital and bus lines. Diode traces should be kept at least 2 cm apart from the high speed digital traces.
7. If it is necessary to cross high speed digital traces, the diode traces and the high speed digital traces should cross at a 90 degree angle.
8. The ideal place to connect the LM95214's GND pin is as close as possible to the Processors GND associated with the sense diode.
9. Leakage current between D+ and GND and between D+ and D- should be kept to a minimum. Thirteen nano-amperes of leakage can cause as much as 0.2°C of error in the diode temperature reading. Keeping the printed circuit board as clean as possible will minimize leakage current.

Noise coupling into the digital lines greater than 400 mVp-p (typical hysteresis) and undershoot less than 500 mV below GND, may prevent successful SMBus communication with the LM95214. SMBus no acknowledge is the most common symptom, causing unnecessary traffic on the bus. Although the SMBus maximum frequency of communication is rather low (100 kHz max), care still needs to be taken to ensure proper termination within a system with multiple parts on the bus and long printed circuit board traces. An RC lowpass filter with a 3 dB corner frequency of about 40 MHz is included on the LM95214's SMBCLK input. Additional resistance can be added in series with the SMBDAT and SMBCLK lines to further help filter noise and ringing. Minimize noise coupling by keeping digital traces out of switching power supply areas as well as ensuring that digital lines containing high speed data communications cross at right angles to the SMBDAT and SMBCLK lines.

Physical Dimensions inches (millimeters) unless otherwise noted

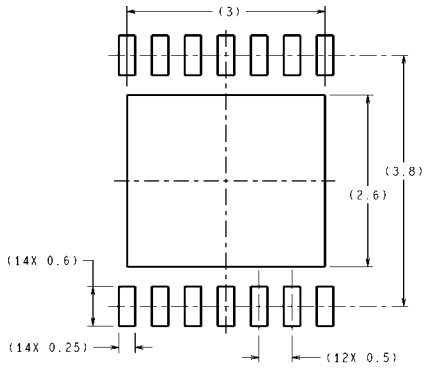

DIMENSIONS ARE IN MILLIMETERS
DIMENSIONS IN () FOR REFERENCE ONLY

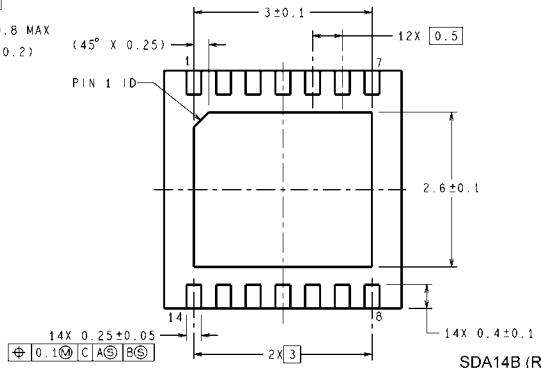
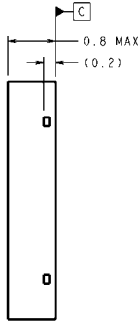
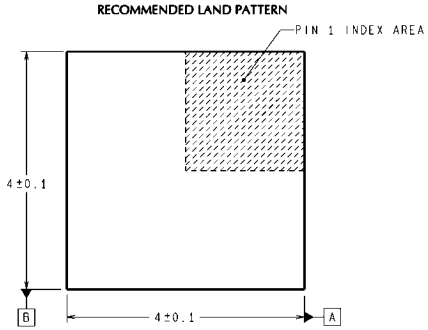
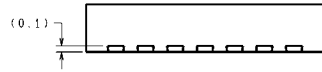

SDA14B (Rev A)

**14-Lead Molded Leadless Leadframe Package (LLP),
Order Number LM95214CISD or LM95214CISDX
NS Package Number SDA14B**

Notes

LM95214

Notes

THE CONTENTS OF THIS DOCUMENT ARE PROVIDED IN CONNECTION WITH NATIONAL SEMICONDUCTOR CORPORATION ("NATIONAL") PRODUCTS. NATIONAL MAKES NO REPRESENTATIONS OR WARRANTIES WITH RESPECT TO THE ACCURACY OR COMPLETENESS OF THE CONTENTS OF THIS PUBLICATION AND RESERVES THE RIGHT TO MAKE CHANGES TO SPECIFICATIONS AND PRODUCT DESCRIPTIONS AT ANY TIME WITHOUT NOTICE. NO LICENSE, WHETHER EXPRESS, IMPLIED, ARISING BY ESTOPPEL OR OTHERWISE, TO ANY INTELLECTUAL PROPERTY RIGHTS IS GRANTED BY THIS DOCUMENT.

TESTING AND OTHER QUALITY CONTROLS ARE USED TO THE EXTENT NATIONAL DEEMS NECESSARY TO SUPPORT NATIONAL'S PRODUCT WARRANTY. EXCEPT WHERE MANDATED BY GOVERNMENT REQUIREMENTS, TESTING OF ALL PARAMETERS OF EACH PRODUCT IS NOT NECESSARILY PERFORMED. NATIONAL ASSUMES NO LIABILITY FOR APPLICATIONS ASSISTANCE OR BUYER PRODUCT DESIGN. BUYERS ARE RESPONSIBLE FOR THEIR PRODUCTS AND APPLICATIONS USING NATIONAL COMPONENTS. PRIOR TO USING OR DISTRIBUTING ANY PRODUCTS THAT INCLUDE NATIONAL COMPONENTS, BUYERS SHOULD PROVIDE ADEQUATE DESIGN, TESTING AND OPERATING SAFEGUARDS.

EXCEPT AS PROVIDED IN NATIONAL'S TERMS AND CONDITIONS OF SALE FOR SUCH PRODUCTS, NATIONAL ASSUMES NO LIABILITY WHATSOEVER, AND NATIONAL DISCLAIMS ANY EXPRESS OR IMPLIED WARRANTY RELATING TO THE SALE AND/OR USE OF NATIONAL PRODUCTS INCLUDING LIABILITY OR WARRANTIES RELATING TO FITNESS FOR A PARTICULAR PURPOSE, MERCHANTABILITY, OR INFRINGEMENT OF ANY PATENT, COPYRIGHT OR OTHER INTELLECTUAL PROPERTY RIGHT.

LIFE SUPPORT POLICY

NATIONAL'S PRODUCTS ARE NOT AUTHORIZED FOR USE AS CRITICAL COMPONENTS IN LIFE SUPPORT DEVICES OR SYSTEMS WITHOUT THE EXPRESS PRIOR WRITTEN APPROVAL OF THE CHIEF EXECUTIVE OFFICER AND GENERAL COUNSEL OF NATIONAL SEMICONDUCTOR CORPORATION. As used herein:

Life support devices or systems are devices which (a) are intended for surgical implant into the body, or (b) support or sustain life and whose failure to perform when properly used in accordance with instructions for use provided in the labeling can be reasonably expected to result in a significant injury to the user. A critical component is any component in a life support device or system whose failure to perform can be reasonably expected to cause the failure of the life support device or system or to affect its safety or effectiveness.

National Semiconductor and the National Semiconductor logo are registered trademarks of National Semiconductor Corporation. All other brand or product names may be trademarks or registered trademarks of their respective holders.

Copyright© 2007 National Semiconductor Corporation

For the most current product information visit us at www.national.com



**National Semiconductor
Americas Customer
Support Center**
Email:
new.feedback@nsc.com
Tel: 1-800-272-9959

**National Semiconductor Europe
Customer Support Center**
Fax: +49 (0) 180-530-85-86
Email: europe.support@nsc.com
Deutsch Tel: +49 (0) 69 9508 6208
English Tel: +49 (0) 870 24 0 2171
Français Tel: +33 (0) 1 41 91 8790

**National Semiconductor Asia
Pacific Customer Support Center**
Email: ap.support@nsc.com

**National Semiconductor Japan
Customer Support Center**
Fax: 81-3-5639-7507
Email: jpn.feedback@nsc.com
Tel: 81-3-5639-7560