

LM96530 Ultrasound Transmit/Receive Switch

Check for Samples: [LM96530](#)

FEATURES

- **8-Channel High-Voltage Receive Side Switches without Charge-Injection**
- **Can be Used for Receive Protection and/or Receive Multiplexing with SPI™ Compatible Bus Control**
- **Channel Bandwidth Supports 1MHz to 20MHz Transducers**
- **Input Accepts Pulses and Continuous-Wave Signals within ±60V**
- **Integrated Output Clamping Diodes Limit Output to ±0.7V**
- **Low Harmonic Distortion HD2 at -75dBc at 5MHz**
- **Continuous-Wave Operation**
- **Soft-Switcher Based on a Diode Bridge Architecture Yielding Better Noise Performance and Faster Turn-On and -Off Times than Competing T-Gate Switch Architectures**
- **2.5V to 3.3V CMOS SPI™ Compatible Logic Interface with Daisy Chain Capability**
- **Bias Current Source (I_S) can be Scaled between 0 and 8mA via an External Resistor**

DESCRIPTION

The LM96530 is an eight-channel monolithic high-voltage, high-speed T/R (Transmit/Receive) switch for multi-channel medical ultrasound applications. It is well-suited for use with Texas Instrument's LM965XX series chipset which offers a complete medical ultrasound solution targeted towards low-power, portable systems.

The LM96530 contains eight high-voltage T/R switches with integrated clamping diodes. This chip protects the inputs of the receive channel's LNA (Low Noise Amplifier) from the high-voltage pulses of the transmit channel. Advanced features include a diode bridge with internal current sources that are programmable via an external resistor. Low-power operation is enabled via per-channel-selectable switching.

Texas Instruments also offers a development package for sale which includes a driver hardware and software package with a graphical user interface for configuration and monitoring.

APPLICATIONS

- **Ultrasound Imaging**

Table 1. Key Specifications

	VALUE	UNIT
Input voltage	±60	V
Output voltage clamp ($I_S = 1\text{mA}$)	±0.7	V
On-resistance	18	Ω
Off-isolation at 5MHz	-58	dB
Noise spectral density at 5MHz	0.5	nV/√Hz
Harmonic distortion		
HD2	-75	dB
HD3	-75	dB
Channel crosstalk at 5MHz	-73	dB
Operating Temp.	0 to +70	°C



Please be aware that an important notice concerning availability, standard warranty, and use in critical applications of Texas Instruments semiconductor products and disclaimers thereto appears at the end of this data sheet.

All trademarks are the property of their respective owners.

Block Diagram

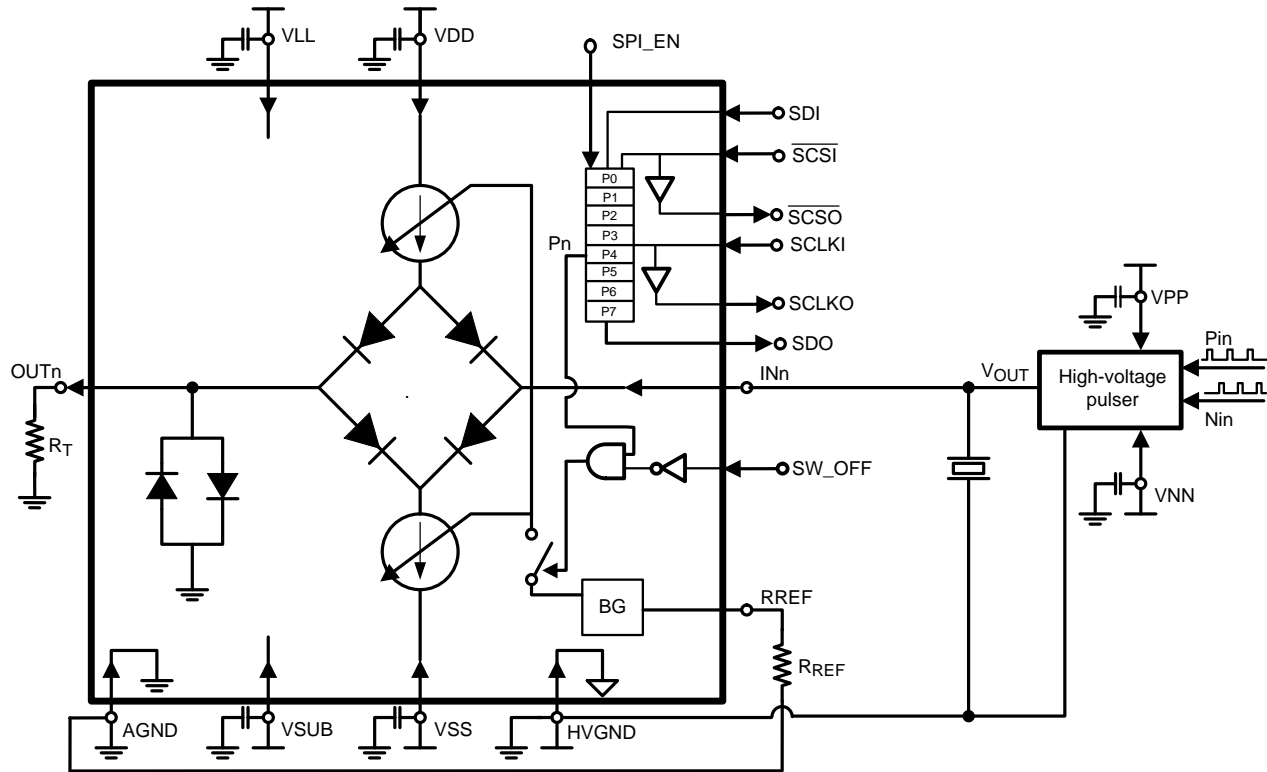

Figure 1.

Typical Application

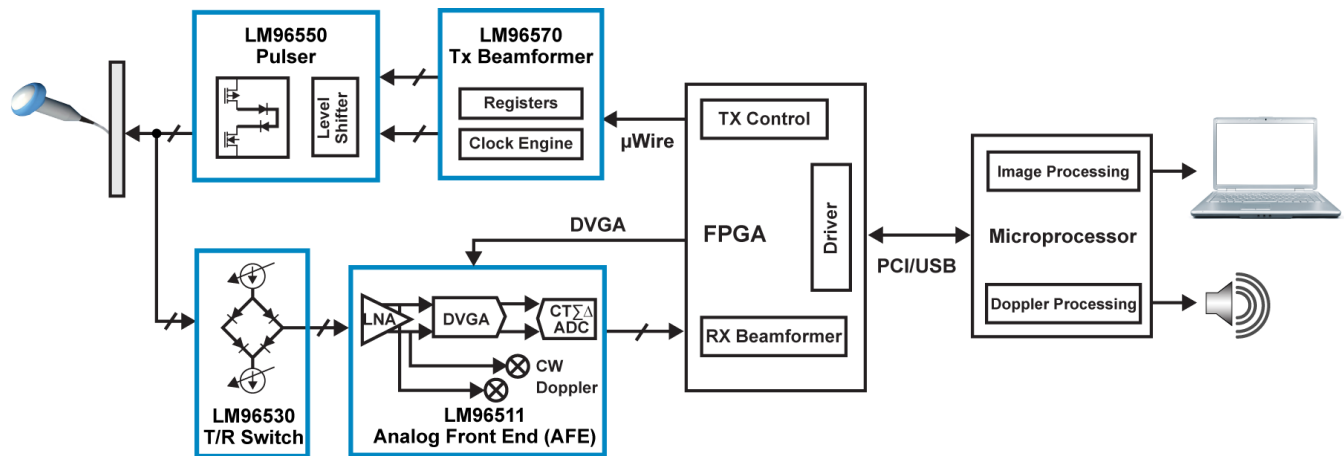

Figure 2. 8-Channel Transmit/Receive Chipset

Pin Diagram

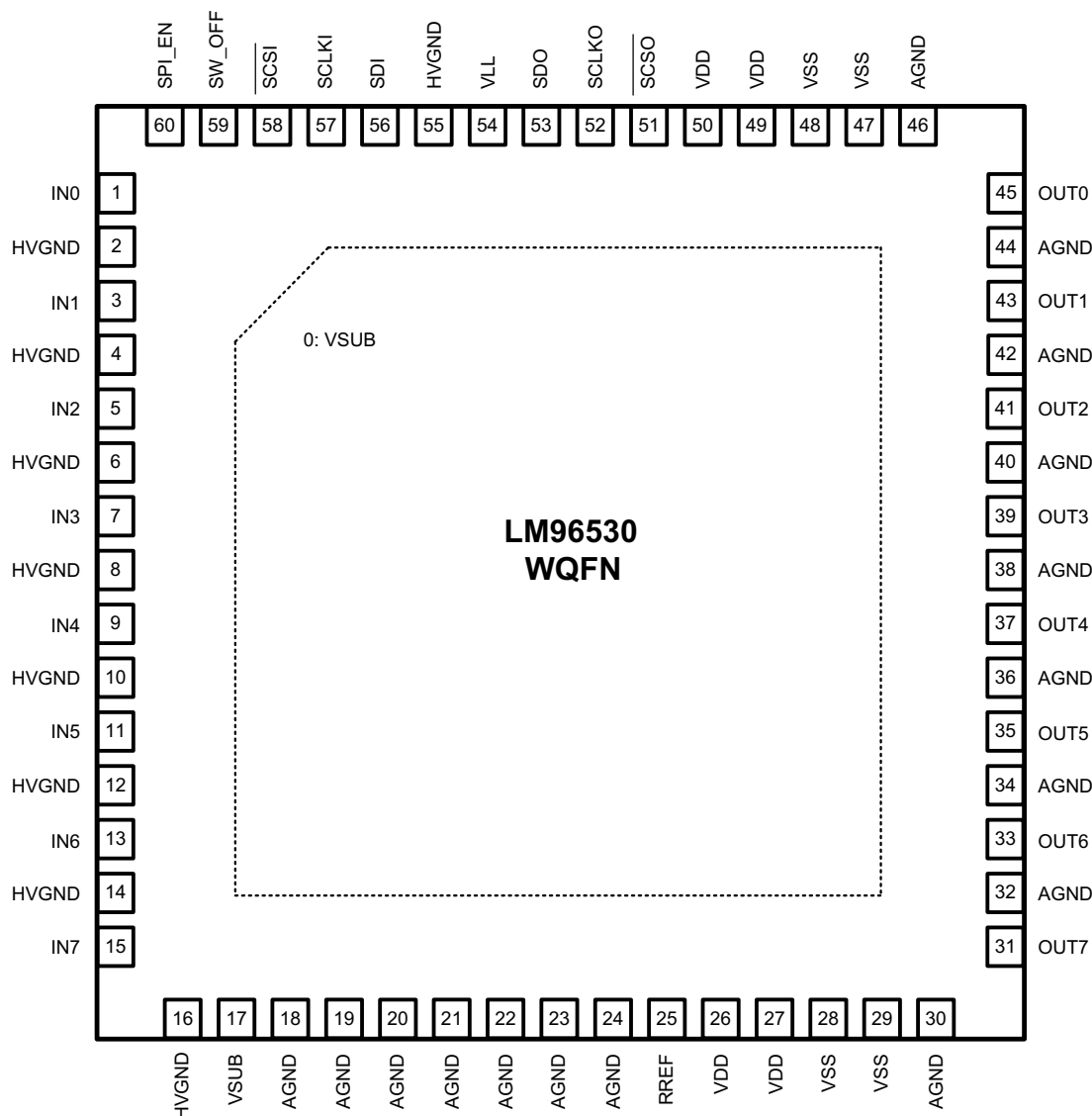

Figure 3. WQFN Package
See Package Number NKA0060A

PIN DESCRIPTIONS

Pin No.	Name	Type	Function and Connection
1, 3, 5, 7, 9, 11, 13, 15	INn n=0,...,7	Input	High-voltage input
45, 43, 41, 39, 37, 35, 33, 31	OUTn n=0,...	Output	Low-voltage output
25	RREF	Output	External resistor to AGND. Used to set internal current sources. R _{REF} = 6.25 kΩ → I _S = 8mA; R _{REF} = 12.5 kΩ → I _S = 4mA; R _{REF} = 25 kΩ → I _S = 2mA; R _{REF} = 50 kΩ → I _S = 1mA
59	SW_OFF	Input	1 = Switch all channels OFF 0 = Use SPI™ to control switch

PIN DESCRIPTIONS (continued)

Pin No.	Name	Type	Function and Connection
60	SPI_EN	Input	1 = Enable the SPI™ Interface 0 = Disable the SPI™ Interface and presets SPI™ registers for all switches ON.
58	$\overline{\text{SCSI}}$	Input	SPI™ chip select input, 0 = Chip Select
57	SCKI	Input	SPI™ compatible clock input
56	SDI	Input	SPI™ compatible data input
53	SDO	Output	SPI™ compatible data buffered output
52	SCKO	Output	SPI™ compatible clock buffered output
51	$\overline{\text{SCSO}}$	Output	SPI™ chip select buffered output
26, 27, 49, 50	VDD	Power	Positive analog supply voltage (+5V)
28, 29, 47, 48	VSS	Power	Negative analog supply voltage (-5V)
54	VLL	Power	Logic voltage supply (+2.5 to 3.3V)
0, 17	VSUB	Power	Negative high voltage supply (-65V)
2, 4, 6, 8, 10, 12, 14, 16, 55	HVGND	Ground	High voltage reference potential (0V)
All others	AGND	Ground	Analog and logic low voltage reference input, logic ground (0V)



These devices have limited built-in ESD protection. The leads should be shorted together or the device placed in conductive foam during storage or handling to prevent electrostatic damage to the MOS gates.

Absolute Maximum Ratings ⁽¹⁾⁽²⁾

Maximum Junction Temperature (T_{JMAX})	+150°C
Storage Temperature Range	-40°C to +125°C
Supply Voltage (VDD)	+0.3V to +5.5V
Supply Voltage (VSS)	+0.3V and -5.5V
Supply Voltage (VSUB)	-70V (Must always be most negative voltage)
IO Supply Voltage (VLL)	-0.3V to +3.6V
Voltage at High Voltage Analog Inputs	-70V to 70V
Voltage at Logic Inputs (SCLKI, SDI $\overline{\text{SCSI}}$, SW_OFF)	-0.3V to VLL+0.3V

- (1) Absolute Maximum Ratings are limits beyond which damage to the device may occur. Operating Ratings are conditions under which operation of the device is specified to be functional, but do not ensure specific performance limits. For ensured specifications and test conditions, see the Electrical Characteristics.
- (2) If Military/Aerospace specified devices are required, please contact the Texas Instruments Sales Office/ Distributors for availability and specifications.

Operating Ratings

Operation Junction Temperature	0°C to +70°C	
VDD, -VSS, Analog Supply	+4.7V to 5.3V	
VLL, Logic Supply	+2.4V to 3.5V	
High Voltage Analog Inputs	-60V to +60V, VSUB must be most negative supply	
VSUB, Substrate bias supply	-50V to -65V	
Package Thermal Resistance (θ_{JA})	20°C/W	
ESD Tolerance	Human Body Model ⁽¹⁾	2kV
	Machine Model	150V
	Charge Device Model	750V

- (1) The human body model is a 100pF capacitor discharged through a 1.5kΩ resistor into each pin.

Analog Characteristics

Unless otherwise stated, the following conditions apply.

VLL = +2.5V, VDD = -VSS = 5V, VSUB = -60V, RREF = 50 kΩ, RT = 50Ω, fIN = 5 MHz, SW_OFF = SPI_EN = 0V, TA = 25°C.⁽¹⁾

	Parameter	Test Conditions	Min	Typ	Max	Units
V _{IN}	High Voltage Analog Inputs	V _{SUB} must be most negative voltage. See ⁽²⁾	-60		+60	V
e _n	Voltage Noise	at 5MHz		0.8		nV/√Hz
BW	-3dB Bandwidth			150		MHz
HD2	Second harmonic distortion	0.1V _{PP} 5MHz tone applied as input		-60		dBc
HD3	Third harmonic distortion			-65		dBc
X _{TALK}	Channel crosstalk			-69		dB
T _{ON}	Turn-on time			2		μs
T _{OFF}	Turn-off time			0.2		μs
Iso _{off}	Off isolation	0.1Vpp 5MHz tone is applied as input		-55		dB
R _{ON}	On resistance of TR switch			125		Ω
I _L	Insertion Loss	f _{IN} = 5MHz		-5.5		dB
V _{CLAMP}	Output clamped voltage			±0.7		V
I _{MISMATCH}	Current source mis-match			0.03	0.2	mA
VDD, VSS	Power Supply Current			14	20	mA
VLL				5		μA
V _{SUB}				0.45		mA

(1) Min and Max limits are 100% production tested at 25°C. Limits over the operating temperature range are specified through correlation using Statistical Quality Control (SQC) methods. Limits are used to calculate Average Outgoing Quality Level (AOQL).

(2) Total input signal levels, including any transient voltage overshoots, must be within this maximum voltage range.

Unless otherwise stated, the following conditions apply

VLL = +2.5V, VDD = -VSS = 5V, VSUB = -60V, RREF = 25 kΩ, RT = 50Ω, fIN = 5MHz, SW_OFF = SPI_EN = 0V, TA = 25°C.⁽¹⁾

	Parameter	Test Conditions	Min	Typ	Max	Units
V _{IN}	High Voltage Analog Inputs	V _{SUB} must be most negative voltage. See ⁽²⁾	-60		+60	V
e _n	Voltage Noise	at 5MHz		0.7		nV/√Hz
BW	-3dB Bandwidth			150		MHz
HD2	Second harmonic distortion	0.1V _{PP} 5MHz tone applied as input		-67		dBc
HD3	Third harmonic distortion			-70		dBc
X _{TALK}	Channel crosstalk			-73		dB
T _{ON}	Turn-on time			2		μs
T _{OFF}	Turn-off time			0.2		μs
Iso _{off}	Off isolation	0.1Vpp 5MHz tone is applied as input		-58		dB
R _{ON}	On resistance of TR switch			48		Ω
I _L	Insertion Loss	f _{IN} = 5MHz		-4		dB
V _{CLAMP}	Output clamped voltage			±0.75		V
I _{MISMATCH}	Current source mis-match			0.1	0.35	mA
VDD, VSS	Power Supply Current			23	30	mA
VLL				5		μA
V _{SUB}				1		mA

(1) Min and Max limits are 100% production tested at 25°C. Limits over the operating temperature range are specified through correlation using Statistical Quality Control (SQC) methods. Limits are used to calculate Average Outgoing Quality Level (AOQL).

(2) Total input signal levels, including any transient voltage overshoots, must be within this maximum voltage range.

Unless otherwise stated, the following conditions apply

VLL = +2.5V, VDD = -VSS = 5V, VSUB = -60V, R_{REF} = 12.5 k Ω , R_T = 50 Ω , f_{IN} = 5MHz, SW_OFF = SPI_EN = 0V, T_A = 25°C.⁽¹⁾

Parameter		Test Conditions	Min	Typ	Max	Units
V _{IN}	High Voltage Analog Inputs	VSUB must be most negative voltage. See ⁽²⁾	-60		+60	V
e _n	Voltage Noise	at 5MHz		0.55		nV/ $\sqrt{\text{Hz}}$
BW	-3dB Bandwidth			180		MHz
HD2	Second harmonic distortion	0.1V _{PP} 5MHz tone applied as input		-73		dBc
HD3	Third harmonic distortion			-75		dBc
X _{TALK}	Channel crosstalk			-73		dB
T _{ON}	Turn-on time			2		μs
T _{OFF}	Turn-off time			0.2		μs
Iso _{off}	Off isolation	0.1V _{pp} 5MHz tone is applied as input		-58		dB
R _{ON}	On resistance of TR switch			27		Ω
I _L	Insertion Loss	f _{IN} = 5MHz		-3		dB
V _{CLAMP}	Output clamped voltage			± 0.78		V
I _{MISMATCH}	Current source mis-match			0.25	0.6	mA
VDD, VSS	Power Supply Current			40	49	mA
VLL				5		μA
VSUB				2.2		mA

- (1) Min and Max limits are 100% production tested at 25°C. Limits over the operating temperature range are specified through correlation using Statistical Quality Control (SQC) methods. Limits are used to calculate Average Outgoing Quality Level (AOQL).
- (2) Total input signal levels, including any transient voltage overshoots, must be within this maximum voltage range.

Unless otherwise stated, the following conditions apply

VLL = +2.5V, VDD = -VSS = 5V, VSUB = -60V, R_{REF} = 6.25 k Ω , R_T = 50 Ω , f_{IN} = 5MHz, SW_OFF = SPI_EN = 0V, T_A = 25°C.⁽¹⁾

Parameter		Test Conditions	Min	Typ	Max	Units
V _{IN}	High Voltage Analog Inputs	VSUB must be most negative voltage. See ⁽²⁾	-60		+60	V
e _n	Voltage Noise	at 5MHz		0.5		nV/ $\sqrt{\text{Hz}}$
BW	-3dB Bandwidth			180		MHz
HD2	Second harmonic distortion	0.1V _{PP} 5MHz tone applied to input		-75		dBc
HD3	Third harmonic distortion			-75		dBc
X _{TALK}	Channel crosstalk			-73		dB
T _{ON}	Turn-on time			2		μs
T _{OFF}	Turn-off time			0.2		μs
Iso _{off}	Off isolation	0.1V _{pp} 5MHz tone is applied as input		-58		dB
R _{ON}	On resistance of TR switch			18		Ω
I _L	Insertion Loss	f _{IN} = 5MHz		-2.5		dB
V _{CLAMP}	Output clamped voltage			± 0.8		V
I _{MISMATCH}	Current source mis-match			0.6	1.2	mA
VDD, VSS	Power Supply Current			75	86	mA
VLL				5		μA
VSUB				5		mA

- (1) Min and Max limits are 100% production tested at 25°C. Limits over the operating temperature range are specified through correlation using Statistical Quality Control (SQC) methods. Limits are used to calculate Average Outgoing Quality Level (AOQL).
- (2) Total input signal levels, including any transient voltage overshoots, must be within this maximum voltage range.

Digital Characteristics

Unless otherwise stated, the following conditions apply.

VLL = +2.5V, VDD = -VSS = 5V, VSUB = -60V, RREF = 50 kΩ, RT = 50Ω, SW_OFF = 0V, SPI_EN = 2.5V, TA = 25°C.⁽¹⁾

Parameter	Test Conditions	Min	Typ	Max	Unit
V _{IH}	Logical Input "HI" Voltage	2			V
V _{IL}	Logical Input "LO" Voltage			0.5	V
I _{IN-H/L}	Logic Input Current	-1	0.2	+1	μA
V _{OH}	Logical Output "HI" Voltage	2.2			V
V _{OL}	Logical Output "LO" Voltage			0.3	V
t _{SSELS}	SPI™ SCSI Setup Time	11			ns
t _{SSELH}	SPI™ SCSI Hold Time	11			ns
t _{SSELHI}	SPI™ SCSI HI Time		250		ns
t _{WS}	SPI™ SDI Setup Time	11			ns
t _{WH}	SPI™ SDI Hold Time	11			ns
t _{OD}	SPI™ SCLKI to SDO Propagation Delay	C _L = 5 pF		25	ns
t _{VALID}	SPI™ SCSI to T/R Switch State Change Delay		30		ns
t _{SCLK}	SPI™ SCLKI Period	100			ns
	SPI™ SCLKI Duty Cycle	See ⁽²⁾	45	55	% of CLK Period
t _{SCLKOD-H}	SPI™ SCLKI-HI to SCLKO-HI Propagation Delay			12	ns
t _{SCLKOD-L}	SPI™ SCLKI-LO to SCLKO-LO Propagation Delay			12	ns
t _{SCSOD-H}	SPI™ SCSI-HI to SCSO-HI Propagation Delay			12	ns
t _{SCSOD-L}	SPI™ SCLSI-LO to SCLSO-LO Propagation Delay			12	ns
	Maximum Number of Daisy-Chained devices	SCLKI Freq. = 10MHz	16		

- (1) Min and Max limits are 100% production tested at 25°C. Limits over the operating temperature range are specified through correlation using Statistical Quality Control (SQC) methods. Limits are used to calculate Average Outgoing Quality Level (AOQL).
- (2) Specified by design.

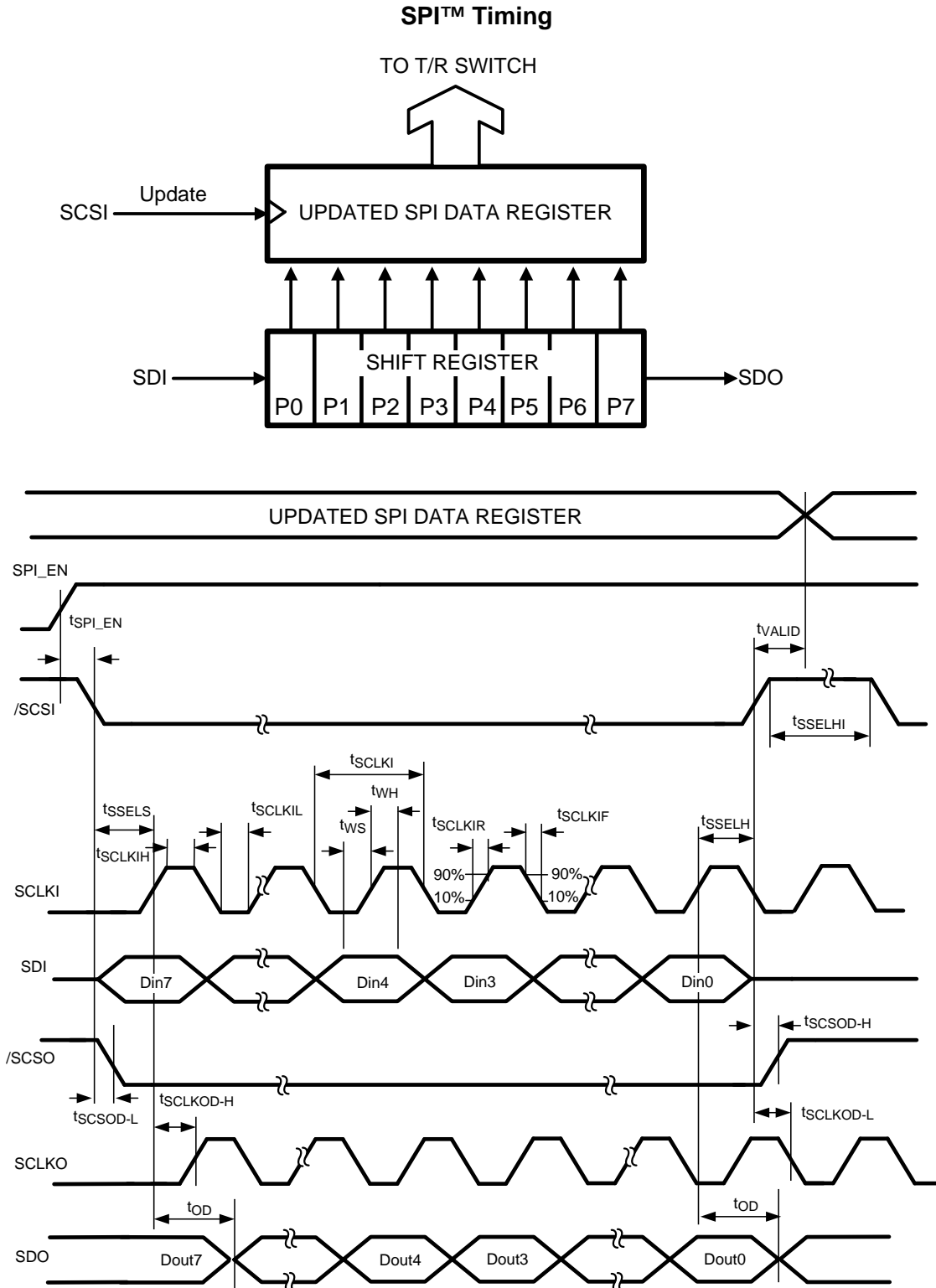

Figure 4. SPI™ Timing Diagram

Typical Performance Characteristics

VLL = +2.5V, VDD = -VSS = 5V, VSUB = -60V, RREF = 50 kΩ, RT = 50Ω, fIN = 5 MHz, TA = 25°C.

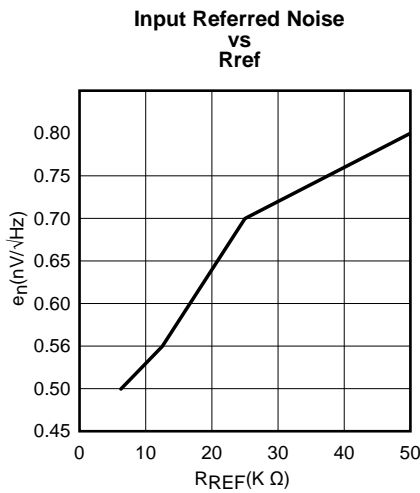

Figure 5.

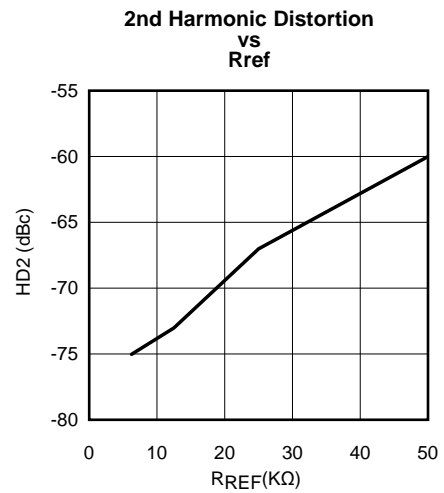

Figure 6.

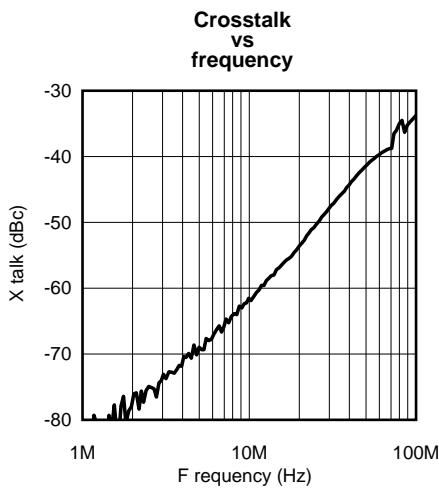

Figure 7.

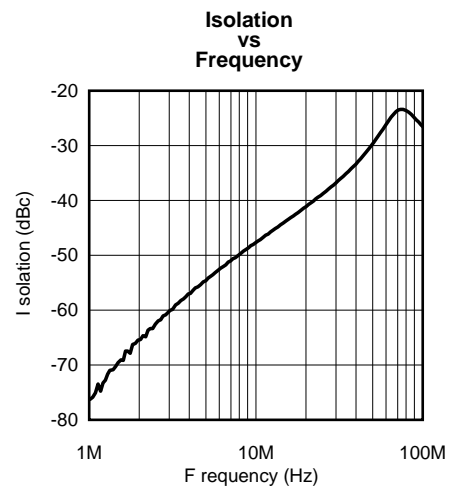

Figure 8.

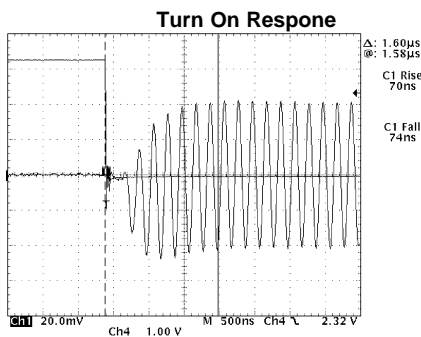

Figure 9.

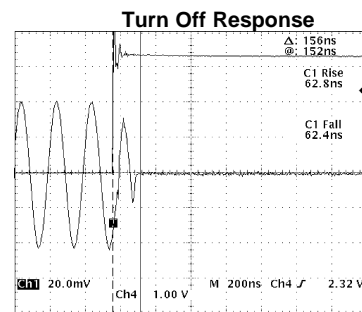

Figure 10.

FUNCTIONAL DESCRIPTION

The LM96530 RX switch provides an 8-channel receive side interface solution for medical ultrasound applications suitable for integration into multi-channel (128 / 256 channel) systems. Its diode-bridge-based architecture allows high-speed low-distortion channel designs targeting low-power, portable systems. A complete system can be designed using Texas Instruments' companion LM965XX chipset.

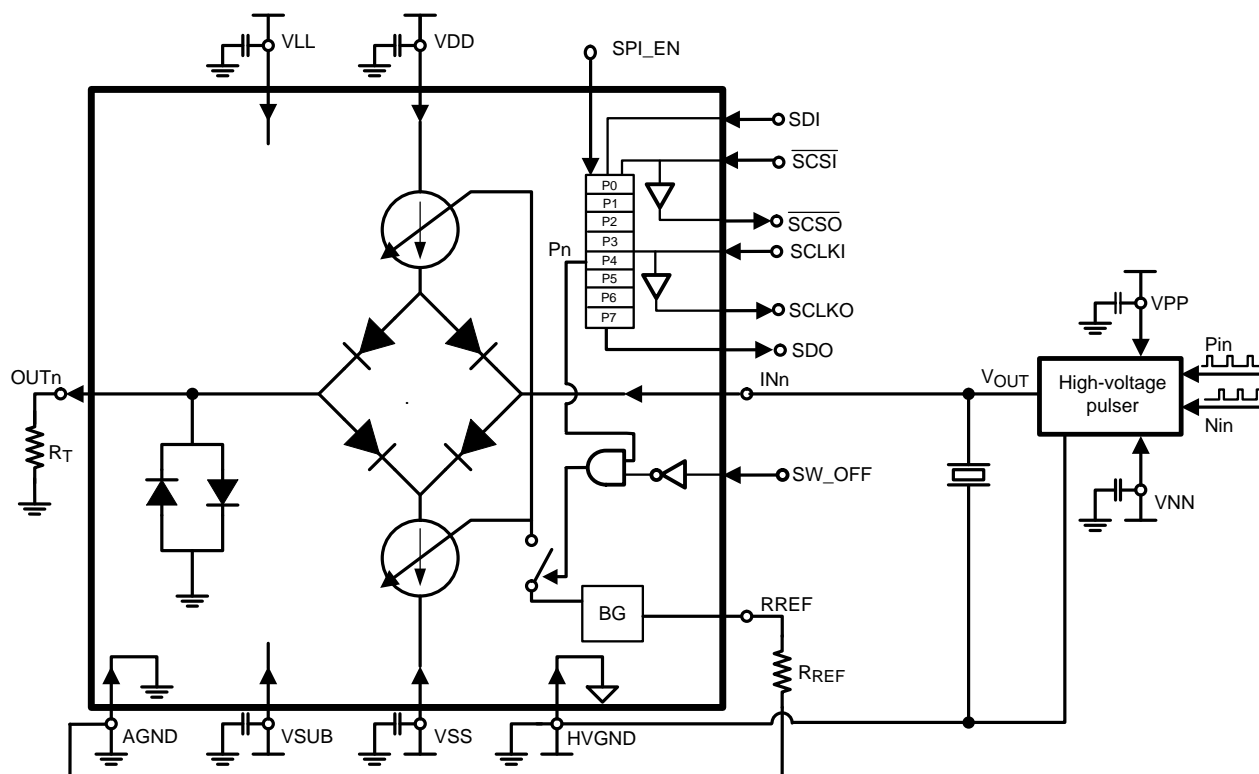

Figure 11. Block Diagram of T/R Channel

A functional block diagram of the IC is shown in [Figure 11](#). Each RX switch channel on the IC has a high-voltage input that can be directly connected to a transducer driven by a high-voltage pulser, such as the LM96550. The input feeds into a diode bridge with its output being diode-clamped to $\pm 0.7V$. The diode bridge bias current is set to 1 mA with $R_{ref} = 50K\Omega$. Therefore, the output can be directly connected to a low noise amplifier (LNA) stage which must be protected from the high-voltage signals on the transducer.

The bias current of the bridge is determined by two equally-sized current sources with their current value ranging between 0 and 8mA depending on the external resistor R_{ref} at the input of the bandgap reference block. While the bias current is the same value for all channels on the IC, each channel can be switched on and off individually with an 8-bit shift register that is programmed via a SPI™ compatible bus.

The on-chip analog circuitry requires dual 5V supplies VDD and VSS, a single logic supply VLL, and a high voltage negative bias, VSUB.

SERIAL INTERFACE OPERATION

The digital interface is comprised of an 8-bit shift register and a latch. Each bit controls one T/R switch channel, where the MSB bit, i.e., the first bit written (D7) controls channel 7, and the LSB bit (D0) controls channel 0. The three input pins, SDI, SCSi and SCKI, are all Schmitt Trigger inputs with 0.5V typical hysteresis. The output pins SDO, SCSO, and SCKO are SPI™ compatible. The serial data input SDI is synchronously read into the shift register on the rising edge of the clock SCKI. When SCSi changes from low to high, the data in the shift register is transferred to the latch circuit, and output on the parallel data signals P0 through P7 which drive the switched bias current sources for channels $n=0, \dots, 7$, respectively. When SCSi changes from high to low, the latch output Pn, and thus the biasing condition, does not change.

DAISY CHAINING MULTIPLE LM96530 ICs

For connecting multiple T/R switch ICs, the LM965XX SPI™-compatible bus can be daisy-chained up to 16 ICs at 10MHz SCLKI for easy PCB routing. The inputs SDI, SCSi and SCLKI are daisy-chained together with SDO, SCsO and SCLKO. Therefore, the next IC's SDI is connected to the previous IC's SDO. Similarly, the next IC's SCSi is connected to the previous IC's SCsO, and the next IC's SCLKI is connected to the previous IC's SCLKO, as shown in Figure 12. Daisy-chaining multiple LM96530 devices amounts to one large shift register with the number of bits being equal to 8 times the number of LM96530 ICs. For example, if 3 LM96530 ICs are daisy-chained, one can picture a 24-bit shift register. Thus, the MSB or first bit written on the SDI line (D23) will control channel 7 of the last LM96530, i.e., the IC that is daisy-chained the farthest away from the SPI master. The LSB or last bit written on the SDI line (D0) will control channel 0 of the first LM96530, i.e., the IC that is closest to the SPI master. It is important to note that if only one particular channel of an IC in the daisy-chain requires updating, all of the ICs, i.e., the entire shift register, must be written to.

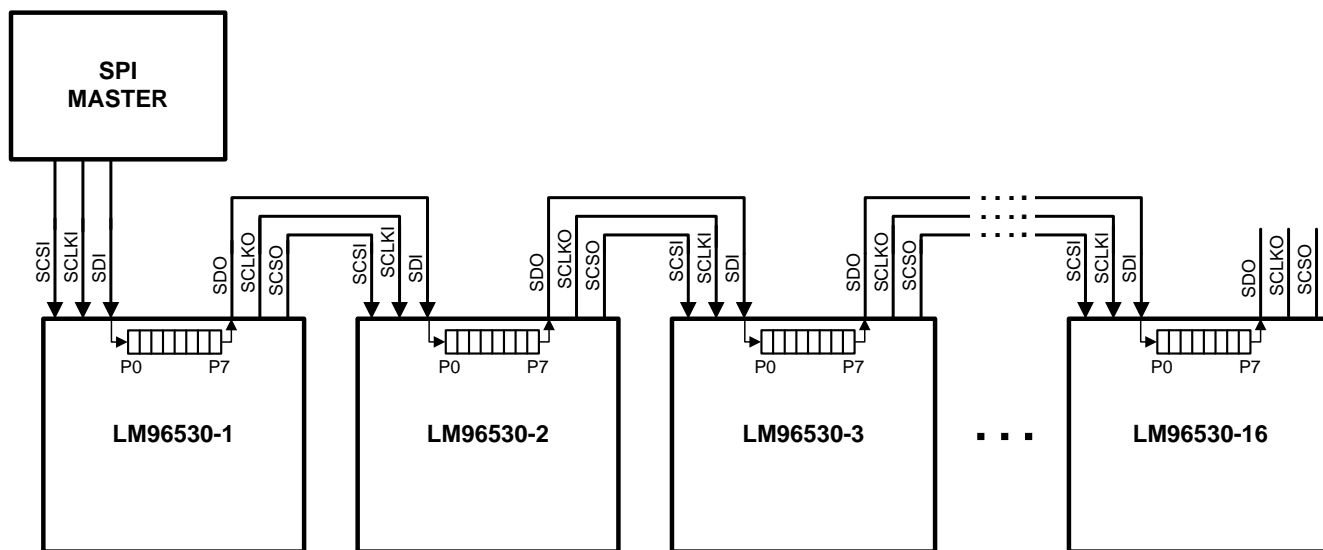

Figure 12. 16 LM96530 Devices Daisy Chained at SCLKI = 16MHz

BASIC OPERATION WITHOUT SERIAL INTERFACE COMMUNICATION

To disable the SPI™ compatible interface, connect the pin SPI_EN to AGND. To reverse bias all 8 channels of the T/R switch, connect the pin, SW_OFF to VLL. To forward bias all 8 channels of the T/R switch, connect the pin, SW_OFF to AGND.

POWER-UP AND POWER-DOWN SEQUENCES

VSUB needs to always be the most negative supply – equal to or more negative than VSS or the most negative transmit pulse at all times. **The power sequence should be to applied to VSUB first, followed by the remaining supplies in any order.**

REVISION HISTORY

Changes from Revision E (May 2013) to Revision F	Page
• Changed layout of National Data Sheet to TI format	11

PACKAGING INFORMATION

Orderable Device	Status (1)	Package Type	Package Drawing	Pins	Package Qty	Eco Plan (2)	Lead/Ball Finish	MSL Peak Temp (3)	Op Temp (°C)	Top-Side Markings (4)	Samples
LM96530SQ/NOPB	ACTIVE	WQFN	NKA	60	1000	Green (RoHS & no Sb/Br)	SN	Level-2-260C-1 YEAR	0 to 70	LM96530SQ	Samples

(1) The marketing status values are defined as follows:

ACTIVE: Product device recommended for new designs.

LIFEBUY: TI has announced that the device will be discontinued, and a lifetime-buy period is in effect.

NRND: Not recommended for new designs. Device is in production to support existing customers, but TI does not recommend using this part in a new design.

PREVIEW: Device has been announced but is not in production. Samples may or may not be available.

OBSOLETE: TI has discontinued the production of the device.

(2) Eco Plan - The planned eco-friendly classification: Pb-Free (RoHS), Pb-Free (RoHS Exempt), or Green (RoHS & no Sb/Br) - please check <http://www.ti.com/productcontent> for the latest availability information and additional product content details.

TBD: The Pb-Free/Green conversion plan has not been defined.

Pb-Free (RoHS): TI's terms "Lead-Free" or "Pb-Free" mean semiconductor products that are compatible with the current RoHS requirements for all 6 substances, including the requirement that lead not exceed 0.1% by weight in homogeneous materials. Where designed to be soldered at high temperatures, TI Pb-Free products are suitable for use in specified lead-free processes.

Pb-Free (RoHS Exempt): This component has a RoHS exemption for either 1) lead-based flip-chip solder bumps used between the die and package, or 2) lead-based die adhesive used between the die and leadframe. The component is otherwise considered Pb-Free (RoHS compatible) as defined above.

Green (RoHS & no Sb/Br): TI defines "Green" to mean Pb-Free (RoHS compatible), and free of Bromine (Br) and Antimony (Sb) based flame retardants (Br or Sb do not exceed 0.1% by weight in homogeneous material)

(3) MSL, Peak Temp. -- The Moisture Sensitivity Level rating according to the JEDEC industry standard classifications, and peak solder temperature.

(4) Multiple Top-Side Markings will be inside parentheses. Only one Top-Side Marking contained in parentheses and separated by a "~" will appear on a device. If a line is indented then it is a continuation of the previous line and the two combined represent the entire Top-Side Marking for that device.

Important Information and Disclaimer:The information provided on this page represents TI's knowledge and belief as of the date that it is provided. TI bases its knowledge and belief on information provided by third parties, and makes no representation or warranty as to the accuracy of such information. Efforts are underway to better integrate information from third parties. TI has taken and continues to take reasonable steps to provide representative and accurate information but may not have conducted destructive testing or chemical analysis on incoming materials and chemicals. TI and TI suppliers consider certain information to be proprietary, and thus CAS numbers and other limited information may not be available for release.

In no event shall TI's liability arising out of such information exceed the total purchase price of the TI part(s) at issue in this document sold by TI to Customer on an annual basis.

TAPE AND REEL INFORMATION



QUADRANT ASSIGNMENTS FOR PIN 1 ORIENTATION IN TAPE



*All dimensions are nominal

Device	Package Type	Package Drawing	Pins	SPQ	Reel Diameter (mm)	Reel Width W1 (mm)	A0 (mm)	B0 (mm)	K0 (mm)	P1 (mm)	W (mm)	Pin1 Quadrant
LM96530SQ/NOPB	WQFN	NKA	60	1000	330.0	16.4	9.3	9.3	1.3	12.0	16.0	Q1

TAPE AND REEL BOX DIMENSIONS



*All dimensions are nominal

Device	Package Type	Package Drawing	Pins	SPQ	Length (mm)	Width (mm)	Height (mm)
LM96530SQ/NOPB	WQFN	NKA	60	1000	367.0	367.0	38.0

NKA0060A

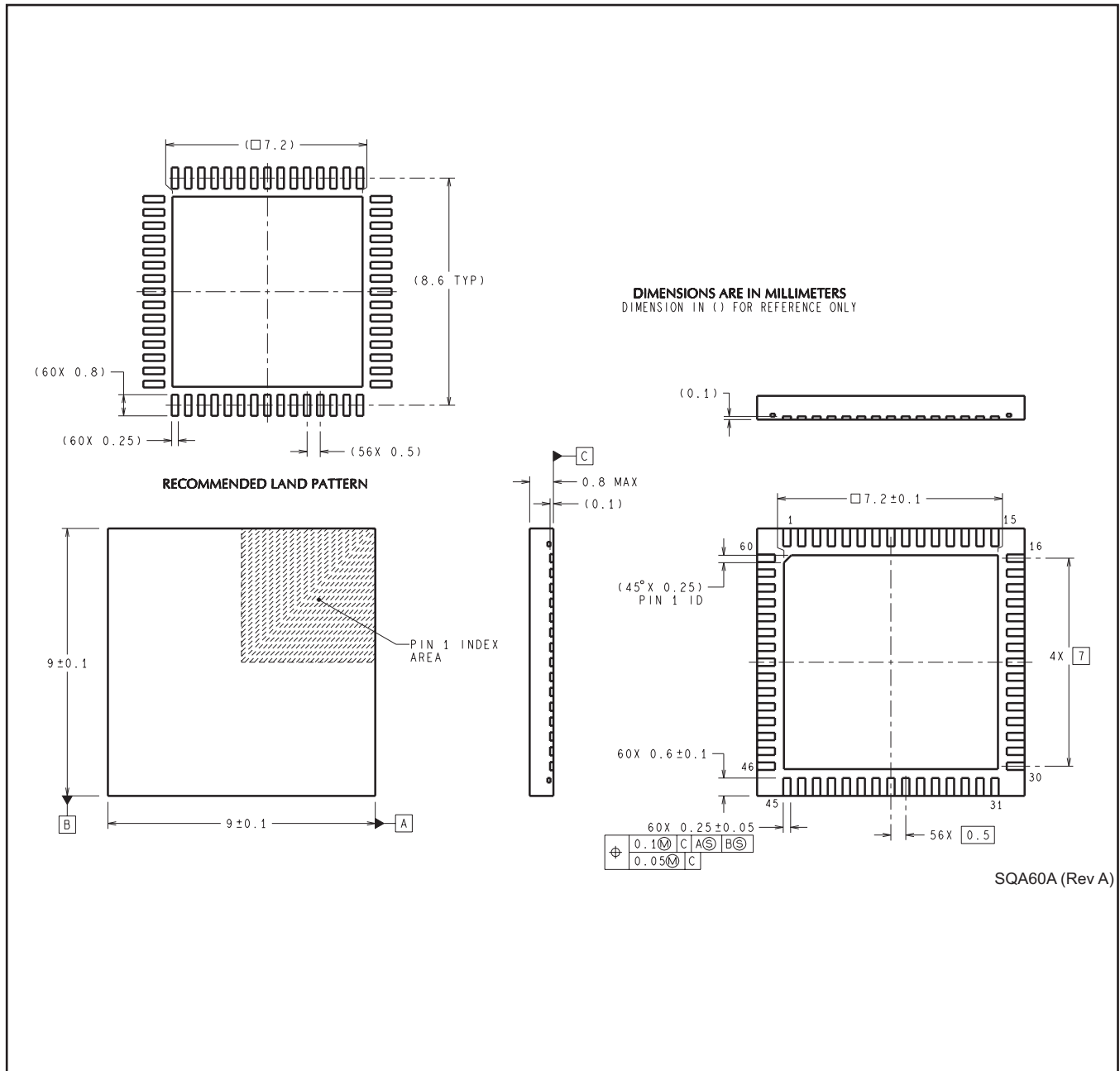

IMPORTANT NOTICE

Texas Instruments Incorporated and its subsidiaries (TI) reserve the right to make corrections, enhancements, improvements and other changes to its semiconductor products and services per JESD46, latest issue, and to discontinue any product or service per JESD48, latest issue. Buyers should obtain the latest relevant information before placing orders and should verify that such information is current and complete. All semiconductor products (also referred to herein as "components") are sold subject to TI's terms and conditions of sale supplied at the time of order acknowledgment.

TI warrants performance of its components to the specifications applicable at the time of sale, in accordance with the warranty in TI's terms and conditions of sale of semiconductor products. Testing and other quality control techniques are used to the extent TI deems necessary to support this warranty. Except where mandated by applicable law, testing of all parameters of each component is not necessarily performed.

TI assumes no liability for applications assistance or the design of Buyers' products. Buyers are responsible for their products and applications using TI components. To minimize the risks associated with Buyers' products and applications, Buyers should provide adequate design and operating safeguards.

TI does not warrant or represent that any license, either express or implied, is granted under any patent right, copyright, mask work right, or other intellectual property right relating to any combination, machine, or process in which TI components or services are used. Information published by TI regarding third-party products or services does not constitute a license to use such products or services or a warranty or endorsement thereof. Use of such information may require a license from a third party under the patents or other intellectual property of the third party, or a license from TI under the patents or other intellectual property of TI.

Reproduction of significant portions of TI information in TI data books or data sheets is permissible only if reproduction is without alteration and is accompanied by all associated warranties, conditions, limitations, and notices. TI is not responsible or liable for such altered documentation. Information of third parties may be subject to additional restrictions.

Resale of TI components or services with statements different from or beyond the parameters stated by TI for that component or service voids all express and any implied warranties for the associated TI component or service and is an unfair and deceptive business practice. TI is not responsible or liable for any such statements.

Buyer acknowledges and agrees that it is solely responsible for compliance with all legal, regulatory and safety-related requirements concerning its products, and any use of TI components in its applications, notwithstanding any applications-related information or support that may be provided by TI. Buyer represents and agrees that it has all the necessary expertise to create and implement safeguards which anticipate dangerous consequences of failures, monitor failures and their consequences, lessen the likelihood of failures that might cause harm and take appropriate remedial actions. Buyer will fully indemnify TI and its representatives against any damages arising out of the use of any TI components in safety-critical applications.

In some cases, TI components may be promoted specifically to facilitate safety-related applications. With such components, TI's goal is to help enable customers to design and create their own end-product solutions that meet applicable functional safety standards and requirements. Nonetheless, such components are subject to these terms.

No TI components are authorized for use in FDA Class III (or similar life-critical medical equipment) unless authorized officers of the parties have executed a special agreement specifically governing such use.

Only those TI components which TI has specifically designated as military grade or "enhanced plastic" are designed and intended for use in military/aerospace applications or environments. Buyer acknowledges and agrees that any military or aerospace use of TI components which have **not** been so designated is solely at the Buyer's risk, and that Buyer is solely responsible for compliance with all legal and regulatory requirements in connection with such use.

TI has specifically designated certain components as meeting ISO/TS16949 requirements, mainly for automotive use. In any case of use of non-designated products, TI will not be responsible for any failure to meet ISO/TS16949.

Products

Audio	www.ti.com/audio
Amplifiers	amplifier.ti.com
Data Converters	dataconverter.ti.com
DLP® Products	www.dlp.com
DSP	dsp.ti.com
Clocks and Timers	www.ti.com/clocks
Interface	interface.ti.com
Logic	logic.ti.com
Power Mgmt	power.ti.com
Microcontrollers	microcontroller.ti.com
RFID	www.ti-rfid.com
OMAP Applications Processors	www.ti.com/omap
Wireless Connectivity	www.ti.com/wirelessconnectivity

Applications

Automotive and Transportation	www.ti.com/automotive
Communications and Telecom	www.ti.com/communications
Computers and Peripherals	www.ti.com/computers
Consumer Electronics	www.ti.com/consumer-apps
Energy and Lighting	www.ti.com/energy
Industrial	www.ti.com/industrial
Medical	www.ti.com/medical
Security	www.ti.com/security
Space, Avionics and Defense	www.ti.com/space-avionics-defense
Video and Imaging	www.ti.com/video

TI E2E Community

e2e.ti.com