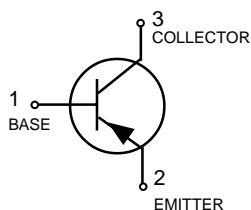


# High Voltage Transistor

## LMBT6520LT1



SOT-23

### MAXIMUM RATINGS

Rating	Symbol	Value	Unit
Collector–Emitter Voltage	$V_{CEO}$	-350	Vdc
Collector–Base Voltage	$V_{CBO}$	-350	Vdc
Emitter–Base Voltage	$V_{EBO}$	-5.0	Vdc
Base Current	$I_B$	-250	mA
Collector Current — Continuous	$I_C$	-500	mAdc

### THERMAL CHARACTERISTICS

Characteristic	Symbol	Max	Unit
Total Device Dissipation FR-5 Board, (1) $T_A = 25^\circ\text{C}$	$P_D$	225	mW
Derate above $25^\circ\text{C}$		1.8	mW/ $^\circ\text{C}$
Thermal Resistance, Junction to Ambient	$R_{\theta JA}$	556	$^\circ\text{C}/\text{W}$
Total Device Dissipation Alumina Substrate, (2) $T_A = 25^\circ\text{C}$	$P_D$	300	mW
Derate above $25^\circ\text{C}$		2.4	mW/ $^\circ\text{C}$
Thermal Resistance, Junction to Ambient	$R_{\theta JA}$	417	$^\circ\text{C}/\text{W}$
Junction and Storage Temperature	$T_J, T_{stg}$	-55 to +150	$^\circ\text{C}$

### DEVICE MARKING

LMBT6520LT1 = 2Z

### ELECTRICAL CHARACTERISTICS ( $T_A = 25^\circ\text{C}$ unless otherwise noted.)

Characteristic	Symbol	Min	Max	Unit
----------------	--------	-----	-----	------

### OFF CHARACTERISTICS

Collector–Emitter Breakdown Voltage ( $I_C = -1.0\text{ mA}$ )	$V_{(BR)CEO}$	-350	—	Vdc
Collector–Base Breakdown Voltage ( $I_E = -100\text{ }\mu\text{A}$ )	$V_{(BR)CBO}$	-350	—	Vdc
Emitter–Base Breakdown Voltage ( $I_E = -10\text{ }\mu\text{A}$ )	$V_{(BR)EBO}$	-5.0	—	Vdc
Collector Cutoff Current ( $V_{CB} = -250\text{ V}$ )	$I_{CBO}$	—	-50	nA
Emitter Cutoff Current ( $V_{EB} = -4.0\text{ V}$ )	$I_{EBO}$	—	-50	nA

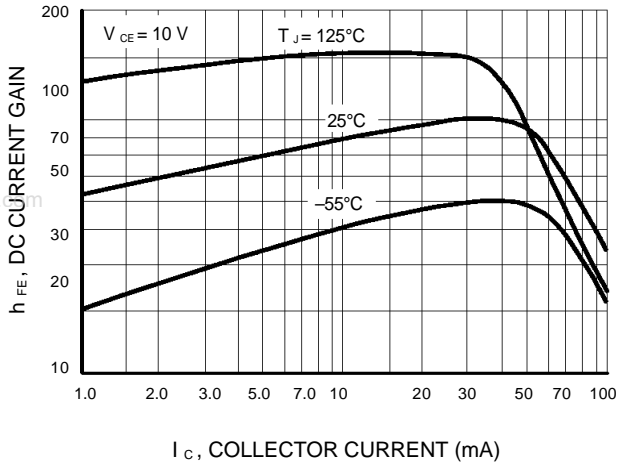
1. FR-5 = 1.0 x 0.75 x 0.062 in.

2. Alumina = 0.4 x 0.3 x 0.024 in. 99.5% alumina.

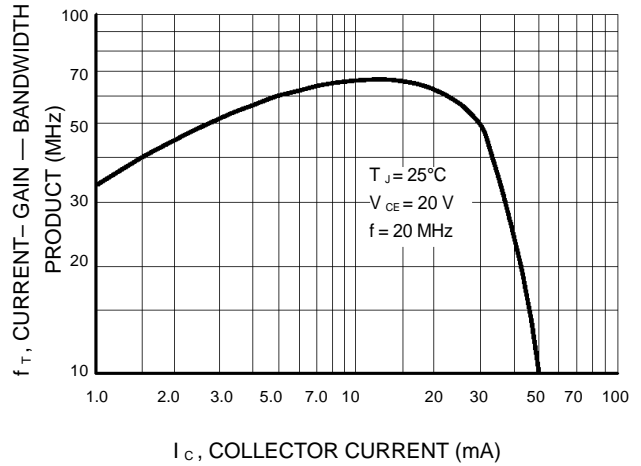
**LMBT6520LT1**
**ELECTRICAL CHARACTERISTICS** ( $T_A = 25^\circ\text{C}$  unless otherwise noted) (Continued)

Characteristic	Symbol	Min	Max	Unit
<b>ON CHARACTERISTICS</b>				
DC Current Gain	$h_{FE}$			—
( $I_C = -1.0\text{ mAdc}$ , $V_{CE} = -10\text{ Vdc}$ )		20	—	
( $I_C = -10\text{ mAdc}$ , $V_{CE} = -10\text{ Vdc}$ )		30	—	
( $I_C = -30\text{ mAdc}$ , $V_{CE} = -10\text{ Vdc}$ )		30	200	
( $I_C = -50\text{ mAdc}$ , $V_{CE} = -10\text{ Vdc}$ )		20	200	
( $I_C = -100\text{ mAdc}$ , $V_{CE} = -10\text{ Vdc}$ )		15	—	
Collector–Emitter Saturation Voltage	$V_{CE(sat)}$			Vdc
( $I_C = -10\text{ mAdc}$ , $I_B = -1.0\text{ mAdc}$ )		—	-0.30	
( $I_C = -20\text{ mAdc}$ , $I_B = -2.0\text{ mAdc}$ )		—	-0.35	
( $I_C = -30\text{ mAdc}$ , $I_B = -3.0\text{ mAdc}$ )		—	-0.50	
( $I_C = -50\text{ mAdc}$ , $I_B = -5.0\text{ mAdc}$ )		—	-1.0	
Base – Emitter Saturation Voltage	$V_{BE(sat)}$			Vdc
( $I_C = -10\text{ mAdc}$ , $I_B = -1.0\text{ mAdc}$ .)		—	-0.75	
( $I_C = -20\text{ mAdc}$ , $I_B = -2.0\text{ mAdc}$ .)		—	-0.85	
( $I_C = -30\text{ mAdc}$ , $I_B = -3.0\text{ mAdc}$ .)		—	-0.90	
Base–Emitter On Voltage	$V_{BE(on)}$			Vdc
( $I_C = -100\text{ mAdc}$ , $V_{CE} = -10\text{ V}$ )		—	-2.0	
<b>SMALL–SIGNAL CHARACTERISTICS</b>				
Current Gain–Bandwidth Product	$f_T$	40	200	MHz
( $V_{CE} = -20\text{ V}$ , $I_C = -10\text{ mA}$ , $f = 20\text{ MHz}$ )				
Collector –Base Capacitance	$C_{cb}$	—	6.0	pF
( $V_{CB} = -20\text{ V}$ , $f = 1.0\text{ MHz}$ )				
Emitter –Base Capacitance	$C_{eb}$	—	100	pF
( $V_{EB} = -0.5\text{ V}$ , $f = 1.0\text{ MHz}$ )				

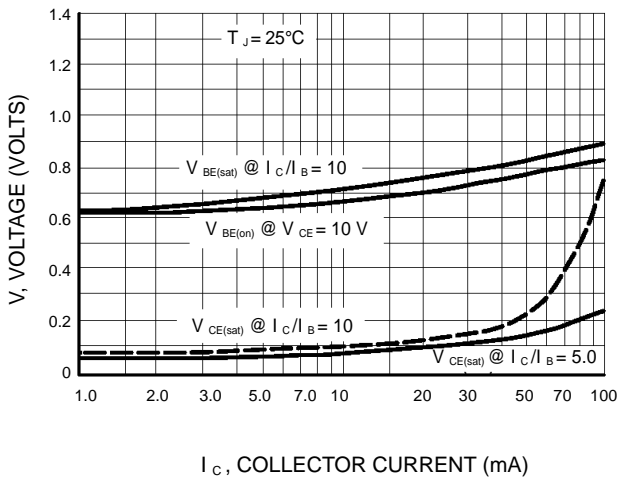
**LMBT6520LT1**



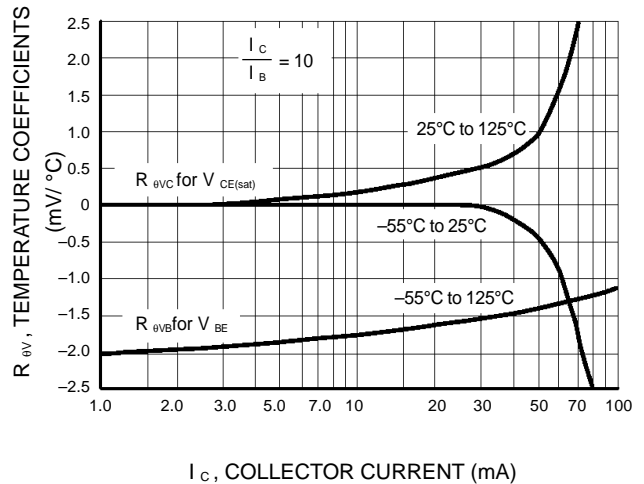
**Figure 1. DC Current Gain**



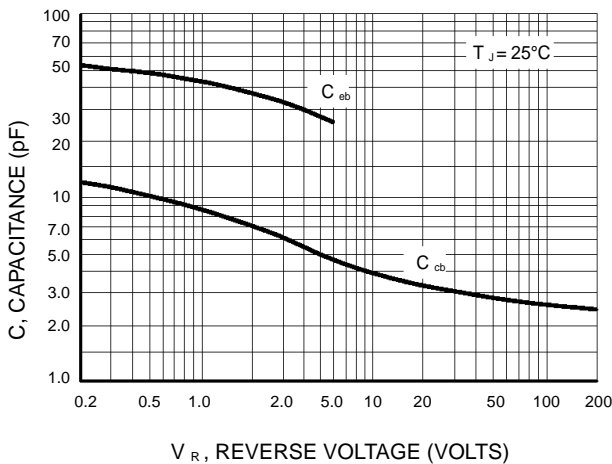
**Figure 2. Current-Gain — Bandwidth Product**



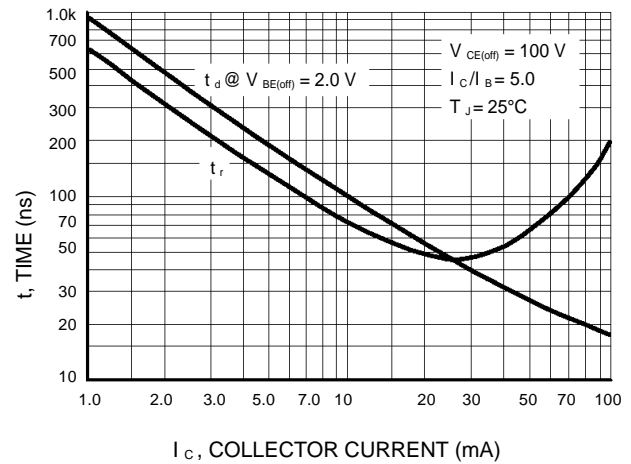
**Figure 3. "On" Voltages**



**Figure 4. Temperature Coefficients**

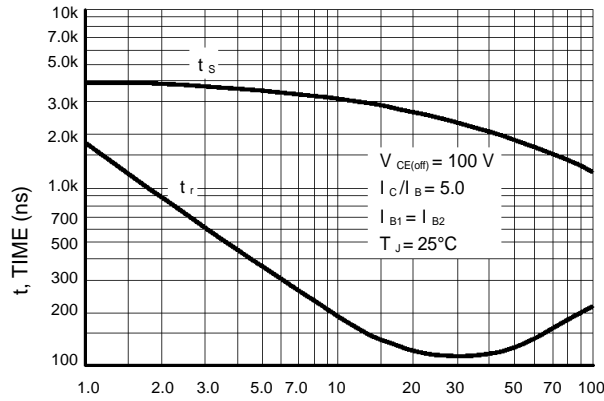


**Figure 5. Capacitance**



**Figure 6. Turn-On Time**

LMBT6520LT1



$I_C$ , COLLECTOR CURRENT (mA)

Figure 7. Turn-On Time

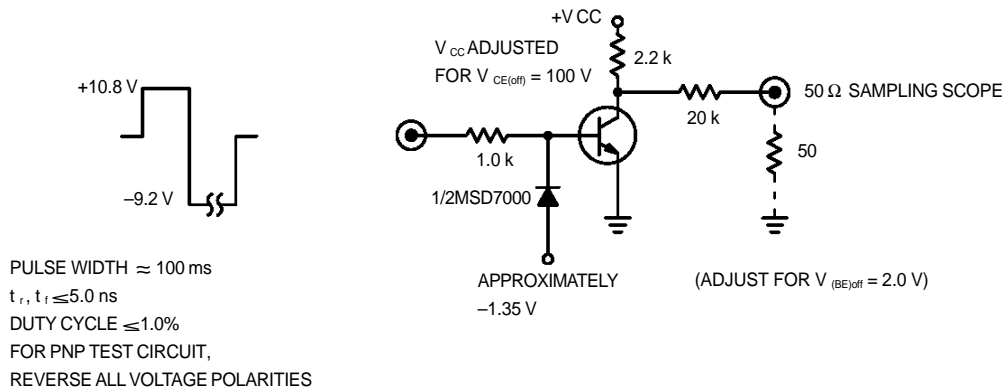


Figure 8. Switching Time Test Circuit

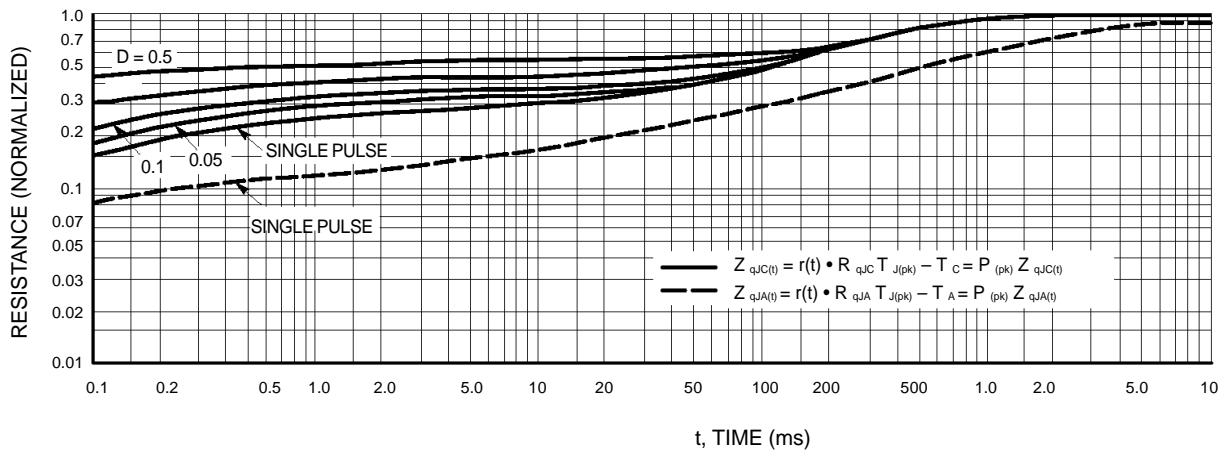
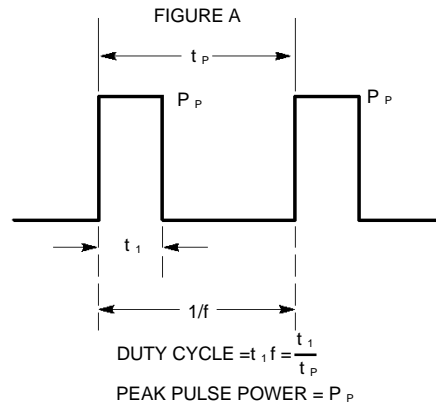


Figure 9. Thermal Response

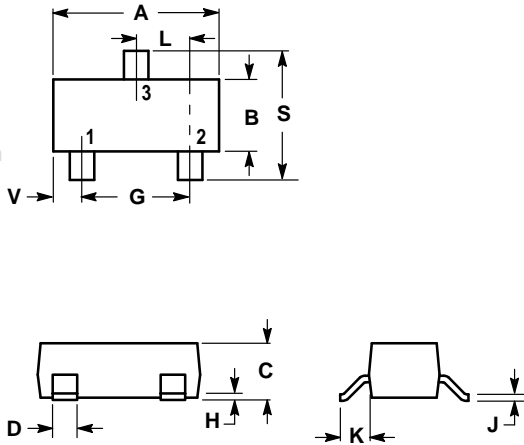
**LMBT6520LT1**

www.DataSheet4U.com

**Design Note: Use of Transient Thermal Resistance Data**

**LMBT6520LT1**

**SOT-23**



NOTES:

1. DIMENSIONING AND TOLERANCING PER ANSI Y14.5M, 1982.
2. CONTROLLING DIMENSION: INCH.

DIM	INCHES		MILLIMETERS	
	MIN	MAX	MIN	MAX
A	0.1102	0.1197	2.80	3.04
B	0.0472	0.0551	1.20	1.40
C	0.0350	0.0440	0.89	1.11
D	0.0150	0.0200	0.37	0.50
G	0.0701	0.0807	1.78	2.04
H	0.0005	0.0040	0.013	0.100
J	0.0034	0.0070	0.085	0.177
K	0.0140	0.0285	0.35	0.69
L	0.0350	0.0401	0.89	1.02
S	0.0830	0.1039	2.10	2.64
V	0.0177	0.0236	0.45	0.60

- PIN 1. BASE  
 2. EMITTER  
 3. COLLECTOR

