

FEATURES

- ◆ Blue on White STN Type
- ◆ Transmissive Mode
- ◆ High Brightness CFL Backlight

- ◆ High Contrast LC Material
- ◆ Built-in LCD Controller HD61830B

MECHANICAL DATA

Item	Value	Unit
Module Dimensions	159.4*101*11	mm
Viewing Area	123*68	mm
Resolution	240*128	dots
Dot Size	0.47*0.47	mm
Dot Pitch	0.5*0.5	mm
Weight	180	g

OPTICAL DATA

Item	Symbol	Condition	Min	Typ	Max	Unit
Contrast Ratio	K	∅=10°, θ=0°, Note 1	-	(18)	-	-
Brightness	-	T=25°C, IL=5mA, Note 8	(60.0)	(80.0)	-	cd/m ²
Viewing Direction	-	-	6			o'clock
Viewing Angle	∅2 - ∅1	K=2, Note 1	30	40	-	degree
Response Time (Rise)	t _R	∅=10°, θ=0°, Note 1	-	(160)	(210)	ms
Response Time (Fall)	t _F	∅=10°, θ=0°, Note 1	-	(110)	(160)	ms

ABSOLUTE MAXIMUM RATINGS

Item	Symbol	Condition	Min	Max	Unit
Supply Voltage (Logic)	V _{DD} - V _{SS}	-	0	6.5	V
Supply Voltage (LC Drive)	V _{DD} - V _{EE}	-	0	20.5	V
Input Voltage	V _I	-	-0.3	0.3+V _{DD}	V
Operating Temperature	T _{OP}	Note 5,6	0	50	°C
Storage Temperature	T _{ST}	Note 7	-20	60	°C

DATA INTERFACE PIN ASSIGNMENT

Pin No	Symbol	Level	Function
A1	VSS (0V)	-	Ground
A2	VDD (+5V)	-	Power supply for logic circuit
A3	V0	-	Power supply for LCD drive
A4	RS	-	Register select
A5	R/W	-	Read / Write
A6	E	-	Enable
A7-A14	DB0 - DB7	-	Display data
A15	Not CS	-	Chip select
A16	Not RET	-	Reset
A17	VEE (-15V)	-	Power supply for LCD drive
A18	Not DISP OFF	-	NC for ON, GND for OFF
A1 - A20	NC	-	No connection

CFL INTERFACE PIN ASSIGNMENT

Pin No	Symbol	Level	Function
1	GND	-	CFL Ground
2	NC	-	No connection
3	NC	-	No connection
4	HV	-	Power supply for CFL

Note 1: Definition of optical data, see page XXX

Note 2: fFRAME=75Hz, VDD-V0=15.8V, Ta=25°C

Note 3: Recommended LCD driving may fluctuate about +/- 1.0V by each module.

Note 4: Flicker or ripples may occur if the LCD is operated at higher or lower frame frequencies.

ELECTRICAL CHARACTERISTICS

Item	Symbol	Condition	Min	Typ	Max	Unit
Supply Voltage (Logic)	V _{DD} - V _{SS}	-	4.75	5.0	5.25	V
Supply Voltage (LC Drive)	V _{EE} - V _{SS}	-	-14.5	-15.0	-15.5	V
Supply Current	I _{DD}	Note 2	-	9.7	12.0	mA
	I _{EE}	Note 2	-	2.5	4.0	mA
Input Voltage (High Level)	V _{IH}	High Level	0.8* V _{DD}	-	V _{DD}	V
Input Voltage (Low Level)	V _{IL}	Low Level	0	-	0.2* V _{DD}	V
Frame Frequency	f _{FLM}	Note 4	-	75	-	Hz
Duty Ratio	-	-	-	1/128	-	-
Recommended LC Drive Voltage	V _{DD} - V _O	Duty=1/128 T=0°C, ∅=10°, Note 3	-	16.9	-	V
		Duty=1/128 T=25°C, ∅=10°, Note 3	-	15.8	-	V
		Duty=1/128 T=40°C, ∅=10°, Note 3	-	15.4	-	V
Backlight Lamp Voltage	V _{BL}	T=25°C	-	360	-	V _{rms}
Backlight Lamp Frequency	f _{BL}	T=25°C	30	70	85	kHz
Backlight Lamp Current	I _{BL}	T=25°C	2.5	5.0	5.5	mA _{rms}
Lamp Start Voltage	V _S	T=25°C, Note 9	(1000)	-	-	V

TIMING CHARACTERISTICS

Item	Symbol	Min	Typ	Max	Unit
Enable cycle time	tCYC	1.0	-	-	us
Enable pulse width (High level)	tWEH	0.45	-	-	us
Enable pulse width (Low level)	tWEL	0.45	-	-	us
Enable rise time	tEr	-	-	25	ns
Enable fall time	tEf	-	-	25	ns
Set up time of CS, R/W, RS	tAS	140	-	-	ns
Set up time of Input Data	tDIS	225	-	-	ns
Data delay time	tDD	-	-	225	ns
Hold time of Data	tH	10	-	-	ns
Hold time of CS, R/W, RS	tAH	10	-	-	ns
Data hold time	tDH	20	-	-	ns

INVERTER AND CONNECTORS

Recommended Inverter	Starter Kit
HITACHI INVC191, INVC445, INVC473	START74xx
Lamp Connector	Lamp Housing Connector
MITSUMI M63M83-04	M61M73-04, M60-04-30-114P or M60-04-30-134P

Note 5: Background colour of the LCD changes depending on temperature. Between 40-50°C optical characteristics of the LCD like contrast and viewing angle change but the LCD remains readable.

Note 6: Operating voltage is increased when CFL is operated at 0°C. Lifetime of CFL is reduced at 0°C.

Note 7: Storage at -20°C < 48 hrs at 60°C < 168 hrs

Note 8: Measurement after 10 minutes of CFL operating. Brightness control 100%

Note 9: Starting discharge voltage is increased when CFL is operating at lower temperature. Please check the characteristics of inverter before applying.

For ordering information of LMG7401PLBC and other Displays, please visit <http://lcdquote.com/LMG7401PLBC> or call +1-888-394-4998.

MECHANICAL DIMENSIONS

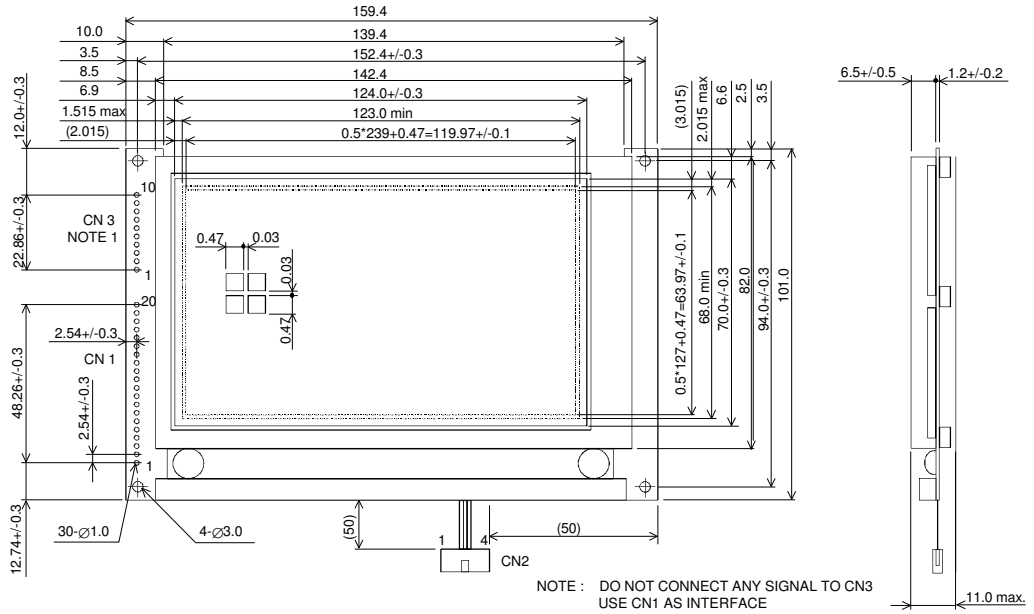

BLOCK DIAGRAM

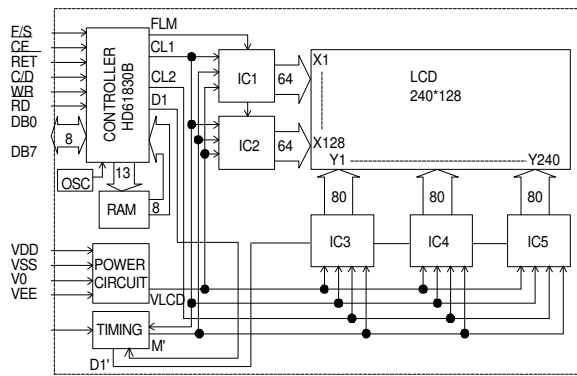

POWER SUPPLY / POWER UP TIMING DIAGRAM

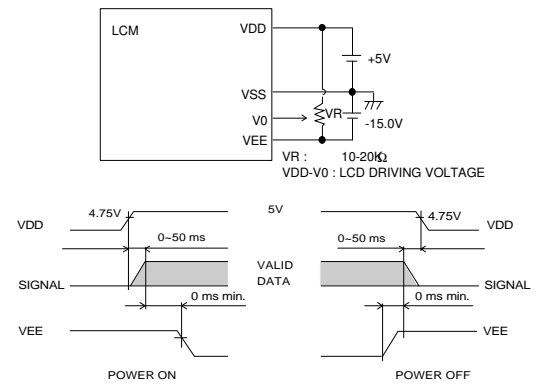

INTERFACE TIMING DIAGRAM

