



## RECORD OF REVISION

DATE	SHEET No.	SUMMARY																
MAR.27.'98	7B64PS 2710- LMG7550XUFC-2 PAGE 10-3/5	CHANGE: CONTRAST IRREGULARITY (SPOT) IS CHANGED.																
Oct.18,'04	7B64PS 2712- LMG7550XUFC-3 PAGE 12-1/1	<p>12. DESIGNATION OF LOT MARK</p> <p>LOT MARK LOT MARK IS CONSISTED OF 4 DIGITS FOR PRODUCTION. LOT AND 8 DIGITS FOR PRODUCTION CONTROL.</p> <div style="text-align: center;"> <table border="1" style="display: inline-table; border-collapse: collapse;"> <tr> <td style="padding: 2px 5px;">2</td> <td style="padding: 2px 5px;">0</td> <td style="padding: 2px 5px;">3</td> <td style="padding: 2px 5px;">1</td> <td style="padding: 2px 5px;"> </td> <td style="padding: 2px 5px;"> </td> <td style="padding: 2px 5px;"> </td> <td style="padding: 2px 5px;"> </td> <td style="padding: 2px 5px;"> </td> <td style="padding: 2px 5px;"> </td> <td style="padding: 2px 5px;"> </td> </tr> </table> </div> <div style="margin-left: 100px;"> <p>└─── DIGITS FOR PRODUCTION CONTROL</p> <p>└─── WEEK</p> <p>└─── MONTH</p> <p>└─── YEAR</p> </div> <p style="text-align: center;">↓</p> <p>12. DESIGNATION OF LOT MARK</p> <p>LOT MARK LOT MARK IS CONSISTED OF 4 DIGITS FOR PRODUCTION. LOT AND 6 DIGITS FOR PRODUCTION CONTROL.</p> <div style="text-align: center;"> <table border="1" style="display: inline-table; border-collapse: collapse;"> <tr> <td style="padding: 2px 5px;">4</td> <td style="padding: 2px 5px;">1</td> <td style="padding: 2px 5px;">0</td> <td style="padding: 2px 5px;">1</td> <td style="padding: 2px 5px;">T</td> </tr> </table> </div> <div style="margin-left: 100px;"> <p>└─── T : MADE IN TAIWAN</p> <p>└─── WEEK</p> <p>└─── MONTH</p> <p>└─── YEAR</p> </div>	2	0	3	1								4	1	0	1	T
2	0	3	1															
4	1	0	1	T														
May.28,'07	7B64PS 2709- LMG7550XUFC-4 PAGE 9-3/3	9.3 Internal Pin Connection Changed : CFL I / F : Mitsumi M63M83 - 04 → JAE IL-G-4S-S3C2-SA																
	7B64PS 2712- LMG7550XUFC-4 PAGE 12-1/1	<p>12. DESIGNATION OF LOT MARK</p> <p>Added</p> <table border="1" style="width: 100%; border-collapse: collapse; text-align: center;"> <thead> <tr> <th style="width: 20%;">REV No.</th> <th style="width: 50%;">ITEM</th> <th style="width: 30%;">LOT No.</th> </tr> </thead> <tbody> <tr> <td>B</td> <td>CFL I/F Connector : Mitsumi M63M83 - 04</td> <td>-</td> </tr> <tr> <td>C</td> <td>CFL I/F Connector : JAE IL-G-4S-S3C2-SA</td> <td>7102T</td> </tr> </tbody> </table>	REV No.	ITEM	LOT No.	B	CFL I/F Connector : Mitsumi M63M83 - 04	-	C	CFL I/F Connector : JAE IL-G-4S-S3C2-SA	7102T							
REV No.	ITEM	LOT No.																
B	CFL I/F Connector : Mitsumi M63M83 - 04	-																
C	CFL I/F Connector : JAE IL-G-4S-S3C2-SA	7102T																

### 3. MECHANICAL DATA

(1) PART NAME	LMG7550XUFC
(2) MODULE SIZE	264.0(W)mm*183.0(H)mm*9.0(D)mm max.
(3) DOT SIZE	0.3 (W)mm*0.3 (H)mm
(4) DOT PITCH	0.33 (W)mm*0.33 (H)mm
(5) NUMBER OF DOTS	640 (W) * 480 (H)DOTS
(6) DUTY	1/244 (DISPLAY IS DIVIDED INTO 2 BLOCKS)
(7) LCD	FILM TYPE BLACK/WHITE (NEGATIVE TYPE) THE UPPER POLARIZER IS ANTI-GLARE TYPE (HARDNESS:3H) THE BOTTOM POLARIZER IS TRANSMISSIVE TYPE.
(8) VIEWING DIRECTION	12 O'CLOCK
(9) BACK LIGHT	COLD CATHODE FLUORESCENT LAMP

## 4. ABSOLUTE MAXIMUM RATINGS

### 4.1 ELECTRICAL ABSOLUTE MAXIMUM RATINGS.

VSS=0V:STANDARD

ITEM	SYMBOL	MIN.	MAX.	UNIT	COMMENT
POWER SUPPLY FOR LOGIC	VDD-VSS	0	6.5	V	
POWER SUPPLY FOR LC DRIVE	VDD-VEE	0	27.5	V	
INPUT VOLTAGE	$V_i$	-0.3	VDD+0.3	V	NOTE 1
INPUT CURRENT	$I_i$	0	1	A	
STATIC ELECTRICITY	-	-	-	-	NOTE 2

NOTE 1 :DISP.OFF,FRAME,LOAD,CP,UD0~UD3,LD0~LD3.

NOTE 2 :.MAKE CERTAINS YOU ARE GROUNDED WHEN HANDLING LCM.

### 4.2 ENVIRONMENTAL ABSOLUTE MAXIMUM RATINGS.

ITEM	OPERATING		STORAGE		COMMENT
	MIN.	MAX.	MIN.	MAX.	
AMBIENT TEMPERATURE	0°C NOTE 6	45°C NOTE 7	-25°C	60°C	NOTE 2,3
HUMIDITY	NOTE 1		NOTE 1		WITHOUT CONDENSATION
VIBRATION	-	2.45m/s <sup>2</sup> (0.25G)	-	11.76m/s <sup>2</sup> (1.2G) NOTE 5	NOTE 4
SHOCK	-	29.4m/s <sup>2</sup> (3G)	-	490m/s <sup>2</sup> (50G) NOTE 5	3 TIMES FOR EACH DIRECTION OF+/-X/+/-Y/+/-Z PULSE WIDTH 10MS
CORROSIVE GAS	NOT ACCEPTABLE		NOT ACCEPTABLE		

NOTE 1 :Ta<=40°C:85%RH max.

Ta>40°C:ABSOLUTE HUMIDITY MUST BE LOWER  
THAN THE HUMIDITY OF 85%RH AT 40°C.

NOTE 2 :Ta AT -25°C----- < 48H,AT 60°C----- < 168H.

NOTE 3 :BACKGROUND COLOR CHANGES SLIGHTLY DEPENDING ON AMBIENT  
TEMPERATURE. THIS PHENOMENON IS REVERSIBLE.

NOTE 4 :5Hz~500Hz (EXCEPT RESONANCE FREQUENCY) FOR EACH DIRECTION  
OF X/Y/Z.

ANY FAILURE CAUSED BY CONNECTOR LOOSENED WHILE TESTING  
SHALL BE IGNORED.

NOTE 5 :THIS MODULE SHOULD BE OPERATED NORMALLY AFTER FINISH  
THE TEST.

ANY FAILURE CAUSED BY CONNECTOR LOOSENED WHILE TESTING  
SHALL BE IGNORED.

NOTE 6 :HIGHER STARTING VOLTAGE OF CFL AND HIGHER LCD DRIVING  
VOLTAGE ARE NEEDED WHILE OPERATING AT 0°C. THE LIFE  
TIME CFL WILL BE REDUCED WHILE OPERATING AT 0°C. THE  
LIFE NEED TO MAKE SURE OF VALUE OF IL AND  
CHARACTERISTICS OF INVERTER. ALSO THE RESPONSE TIME AT 0°C  
WILL BE SLOWER.

NOTE 7 :THERE ARE POSSIBILITY THAT COLOR UN-UNIFORMITY HAPPENED  
WHILE OPERATING AT 45°C

## 5. ELECTRICAL CHARACTERISTICS OF LCM

### 5.1 ELECTRICAL CHARACTERISTICS

ITEM	SYMBOL	CONDITION	MIN.	TYP.	MAX.	UNIT
POWER SUPPLY VOLTAGE FOR LOGIC	VDD-VSS	-	4.75	-	5.25	V
	VEE-VSS			-22V		
INPUT VOLTAGE NOTE 1	VI	H LEVEL	0.7VDD	-	VDD	V
		L LEVEL	0	-	0.3VDD	V
POWER SUPPLY CURRENT FOR LOGIC NOTE 2	IDD	VDD-VSS=5.0V	-	(25.0)	(30.0)	mA
POWER SUPPLY CURRENT FOR LC DRIVING NOTE 2	IEE	VDD-VSS=5.0V	-	(19.0)	(30.0)	mA
RECOMMENDED LC DRIVING VOLTAGE NOTE 3	VDD-VEE	Ta= 0°C , $\phi=0^\circ$	-	(23.9)	-	V
		Ta= 25°C , $\phi=0^\circ$	-	(22.7)	-	V
		Ta=40°C , $\phi=0^\circ$	-	(21.6)	-	V
FRAME FREQUENCY NOTE4	fFRAME	-	(69)	-	(110)	Hz

NOTE 1 :DISP.OFF,FRAME,LOAD,CP,UD0~UD3, LD0~LD3.

NOTE 2 :fFRAME=140Hz,UD0~UD3=0,1,0,1,....LD0~LD3=1.0,1.0,...

VDD-V0=(22.7V),Ta=25°C

NOTE 3 :RECOMMENDED LC DRIVING VOLTAGE FLUCTUATE ABOUT  $\pm 1.0V$  BY EACH MODULE.

TEST PATTERN IS ALL "Q".

NOTE 4 :NEED TO MAKE SURE OF FLICKRING AND RIPPLING OF DISPLAY WHEN SETTING THE FRAME FREQUENCY IN YOUR SET.

## 5.2 ELECTRICAL CHARACTERISTICS OF BACKLIGHT

ITEM	SYMBOL	MIN.	TYP.	MAX.	UNIT	NOTE
LAMP VOLTAGE	VL	-	(430)	-	Vrms	Ta=25°C
FREQUENCY	fL	(50)	-	(70)	KHz	Ta=25°C
LAMP CURRENT	IL	4	4.5	6	mArms	Ta=25°C
STARTING DISCHARGE VOLTAGE	VS NOTE 2	1000	-	-	Vrms	Ta=25°C

NOTE 1 :PLEASE CERTAINLY INFORM HITACHI BEFORE DESIGNING LAMP DRIVE CIRCUIT ACCORDING TO THE ABOVE SPECIFICATIONS.

NOTE 2 :STARING DISCHARGE VOLTAGE IS INCREASED WHEN LCM IS OPERATING AT LOWER TEMPERATURE. PLEASE CHECK THE CHARACTERISTICS OF INVERTER BERFORE APPLING TO YOUR SET.

NOTE 3 :AVERAGE LIFE TIME OF CFL WILL BE DECREASED WHEN LCM IS OPREATING AT LOWER TEMPERATURE.

# 6. OPTICAL CHARACTERISTICS

## 6.1 OPTICAL CHARACTERISTICS

Ta=25°C (BACKLIGHT ON)

ITEM	SYMBOL	CONDITION	MIN.	TYP.	MAX.	UNIT	NOTE
VIEWING ANGLE	$\phi_2 - \phi_1$	$K \geq 2.0$	30	40	-	deg	1,2
CONTRAST RATIO	K	$\phi = 0^\circ \theta = 0^\circ$	(10)	(18)	-	-	3
RESPONSE TIME (RISE)	tr	$\phi = 0^\circ \theta = 0^\circ$	-	160	-	ms	4
RESPONSE TIME (FALL)	tf	$\phi = 0^\circ \theta = 0^\circ$	-	110	-	ms	4

(MEASURE CONDITION BY HITACHI)

NOTE 1. DEFINITION OF  $\theta$  AND  $\phi$   
Z (NORMAL)

NOTE 3. DEFINITION OF CONTRAST "K"

$$K = \frac{\text{BRIGHTNESS ON SELECTED DOT (B1)}}{\text{BRIGHTNESS ON NON-SELECTED DOT (B2)}}$$

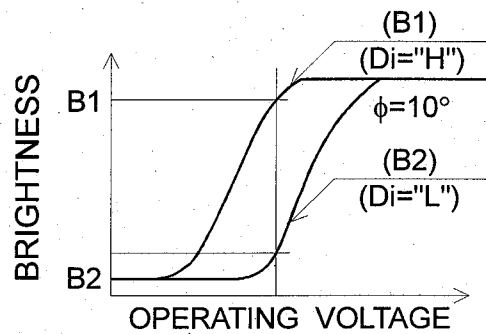
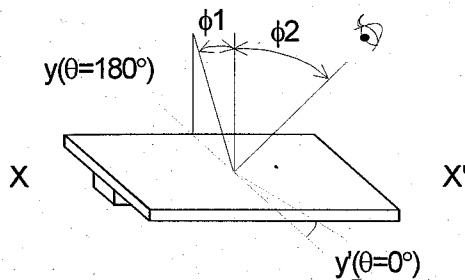

NOTE 2. DEFINITION OF VIEWING ANGLE  $\phi_1$  AND  $\phi_2$

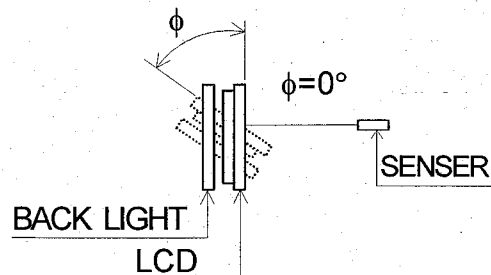
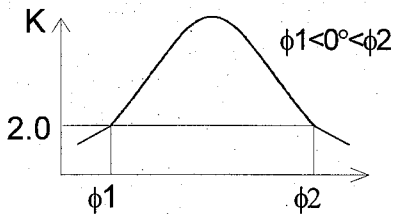

CONTRAST RATIO K VS VIEWING ANGLE  $\phi$

NOTE 4. DEFINITION OF OPTICAL RESPONSE

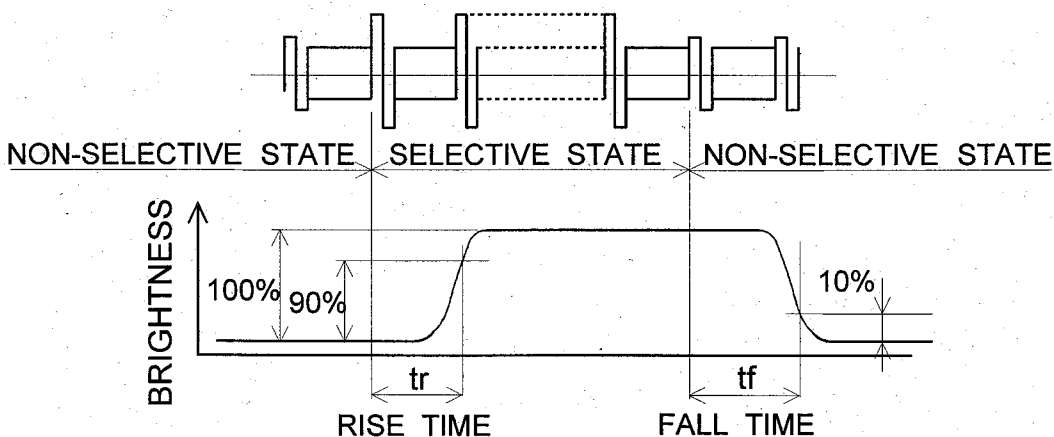

## 6.2 OPTICAL CHARACTERISTICS BACKLIGHT

(LCM, BACKLIGHT ON, Ta=25°C)

ITEM	MIN.	TYP.	MAX.	UNIT	NOTE
BRIGHTNESS	(80.0)	(100.0)	-	cd/m <sup>2</sup>	IL=5mA NOTE 1,2
RISE TIME	-	5	-	MINUTE	IL=5mA BRIGHTNESS 80%
BRIGHTNESS UNIFORMITY	-	-	+/-20	%	UNDERMENTIONED NOTE 1,3

CFL : INITIAL , Ta=25°C , VDD-VEE=(22.7V)  
DISPLAY DATA SHOULD BE ALL "ON".

NOTE 1 MEASUREMENT AFTER 10 MINUTES OF CFL OPERATING.

NOTE 2 BRIGHTNESS CONTROL :100%

NOTE 3 MEASUREMENT OF THE FOLLOWING 9 PLACES ON THE DISPLAY.  
DEFINITION OF THE BRIGHTNESS TOLERANCE.

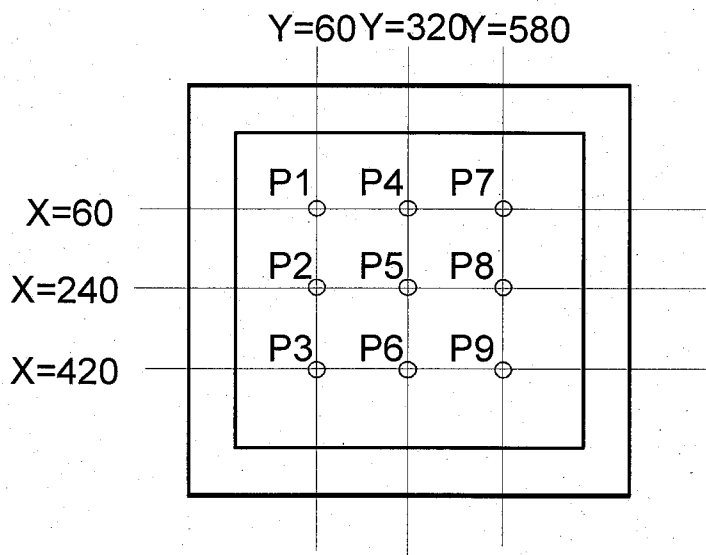

$$\left( \frac{\text{MAX BRIGHTNESS OR MIN BRIGHTNESS} - \text{AVERAGE BRIGHTNESS}}{\text{AVERAGE BRIGHTNESS}} \right) * 100$$



# 7. BLOCK DIAGRAM

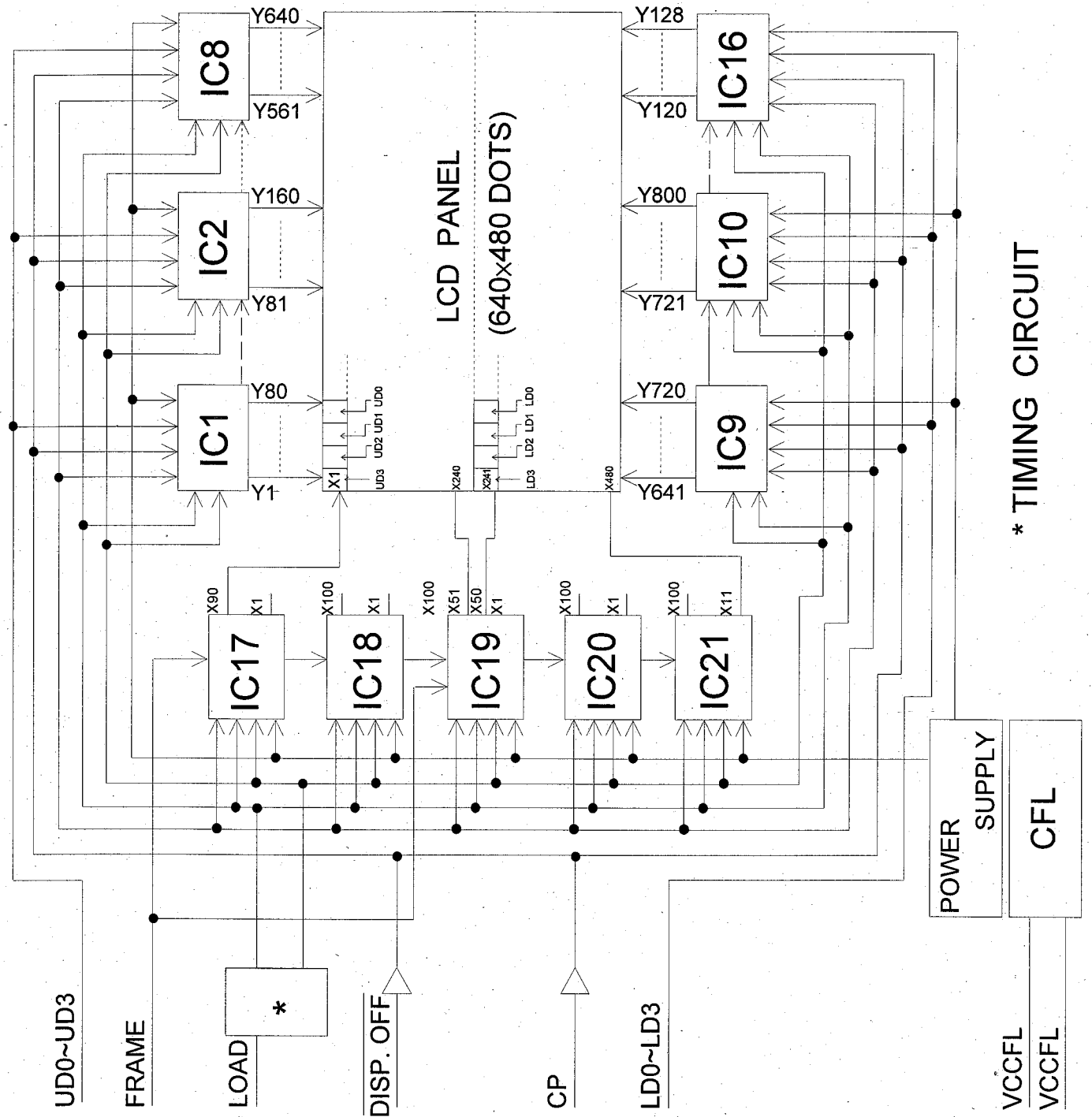

\* TIMING CIRCUIT

# 8. INTERFACE TIMING CHART

## 8.1 TIMING CHART

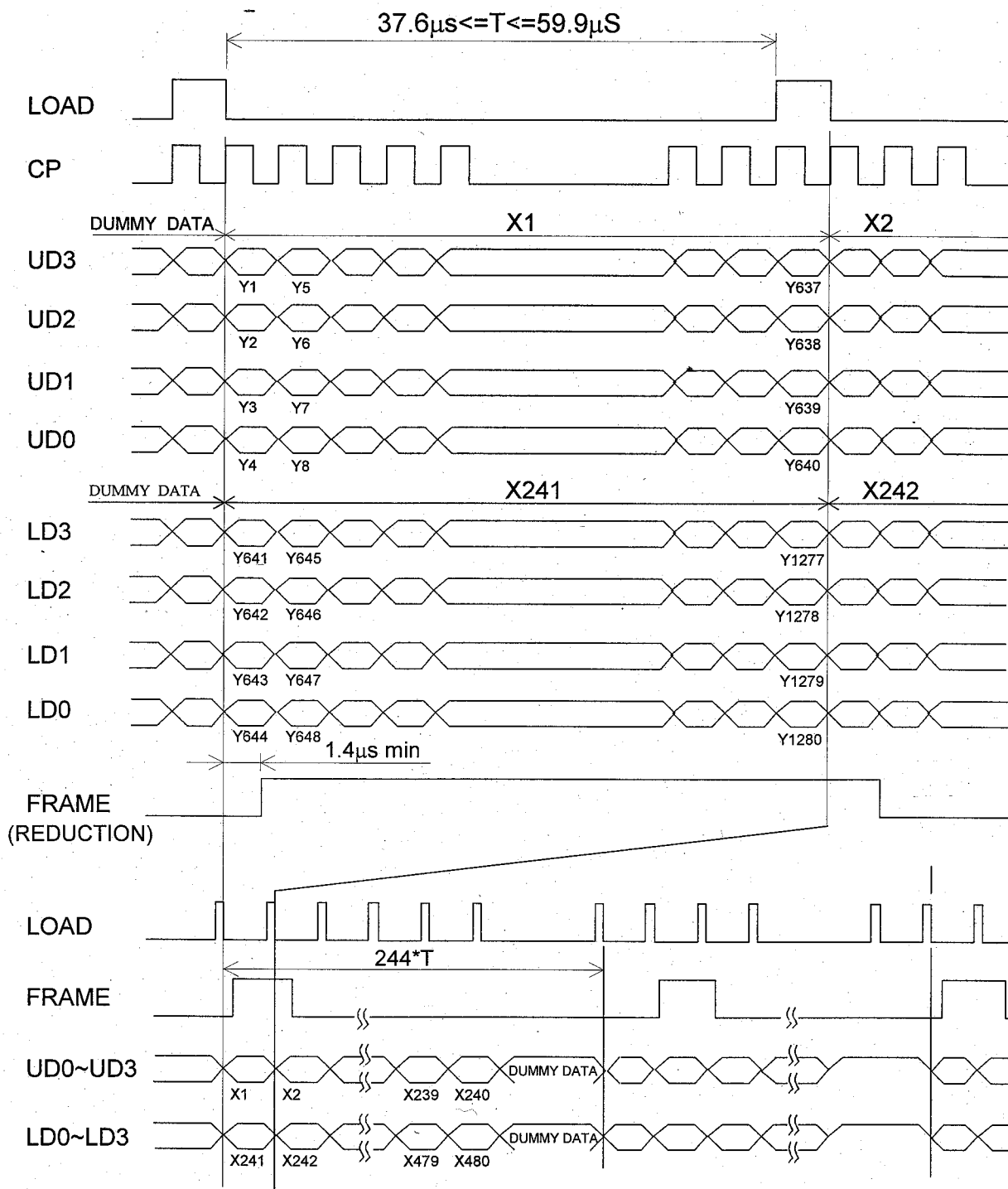

NOTE (1) DUMMY DATA : "H" LEVEL.

NOTE (2) DO NOT INPUT OVER 244 PULSES TO LOAD.

## 8.2 TIMING CHARACTERISTICS

$0^{\circ}\text{C} \leq T_a \leq 50^{\circ}\text{C}$

$V_{DD} = 5\text{V} \pm 0.25\text{V}$

ITEM	SYMBOL	MIN.	TYP.	MAX.	UNIT	
CLOCK FREQUENCY	fCP	-	-	6.5	MHz	
CLOCK PULSE WIDTH	tw	63	-	-	ns	
CLOCK PISE , FALL TIME	tr,tf	-	-	20	ns	
DATA SET UP TIME	tDSU	50	-	-	ns	
DATA HOLD TIME	tDHD	50	-	-	ns	
LOAD SET UP TIME	tLSU	80	-	-	ns	
LOAD→CLOCK TIME	tLC	VDD=3.3V	120	-	-	ns
		VDD=5V	80	-	-	
"FRAME" SET UP TIME	tSETUP	100	-	-	ns	
"FRAME" HOLD TIME	tHOLD	100	-	-	ns	
"LOAD" PULSE WIDTH	twc	125	-	-	ns	

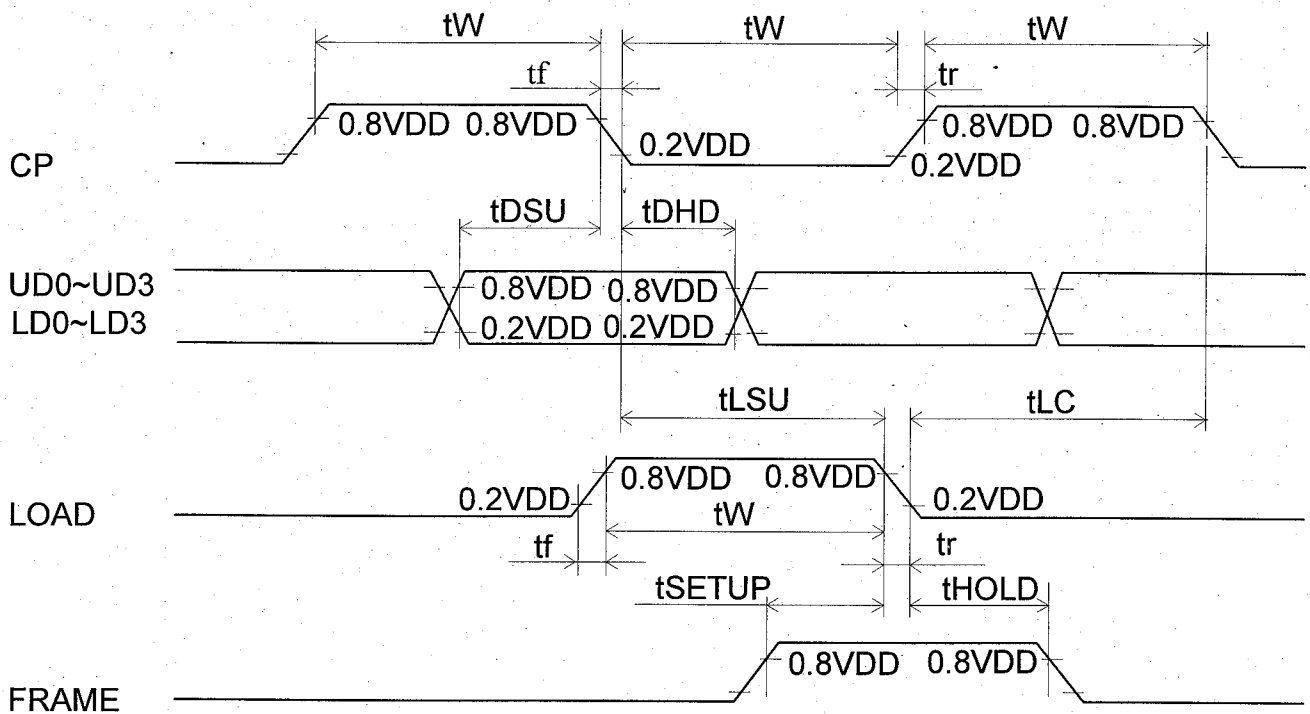

### 8.3 TIMING OF POWER SUPPLY AND INTERFACE SIGNAL

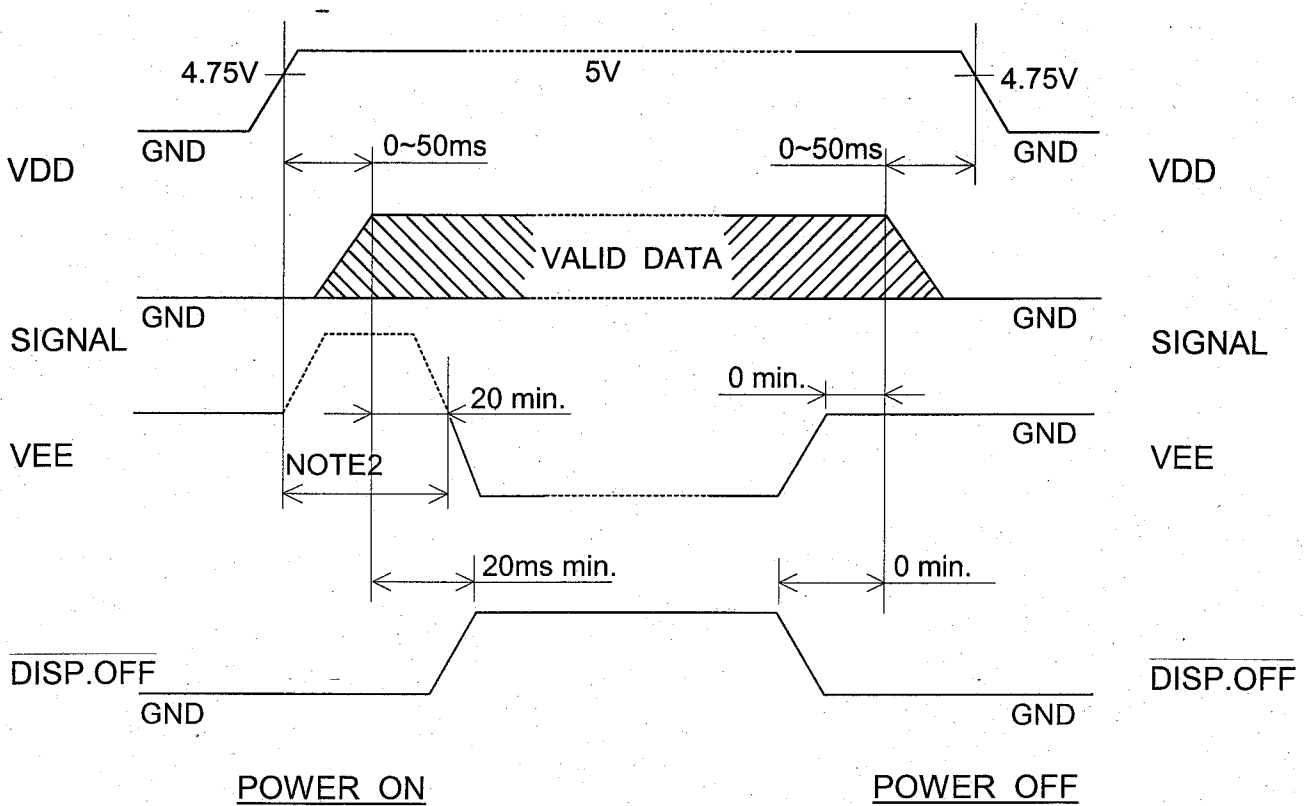

- NOTE 1. THE MISSING PIXELS MAY OCCUR WHEN THE LCM IS DRIVEN BEYOND ABOVE POWER INTERFACE TIMING SEQUENCE.
- NOTE 2. IN CASE OF NOT USING DISP.OFF CONTROLLING, VEE SHOULD BE AT VDD LEVEL OR OPEN IN THIS TIME PERIOD.

### 8.4 POWER SUPPLY FOR LCM (EXAMPLE)

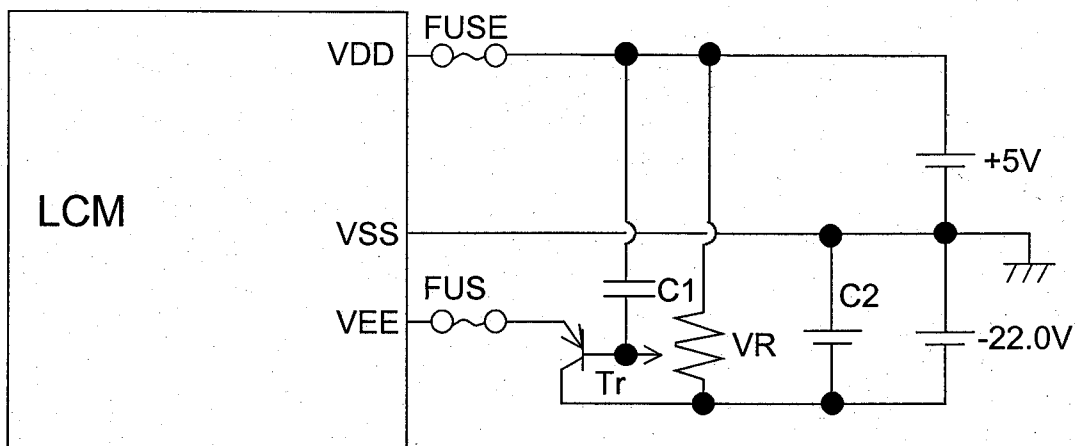

- C1,C2 : 3.3 $\mu$ F(ALUMINIUM ELECTROLYTIC CAPACITOR)  
 VR : 10 $\mu$ 20K $\Omega$   
 Tr : 2SA673APKC (HFE=100,IC=500mA)OR EQUIVALENT TR.

9. DIMENSIONAL OUTLINE  
9.1 DIMENSIONAL OUTLINE

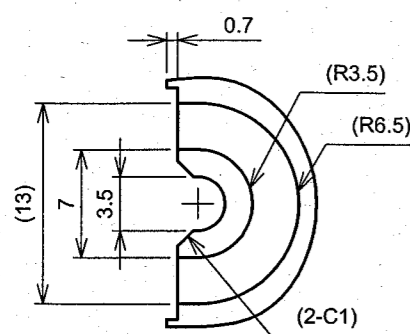
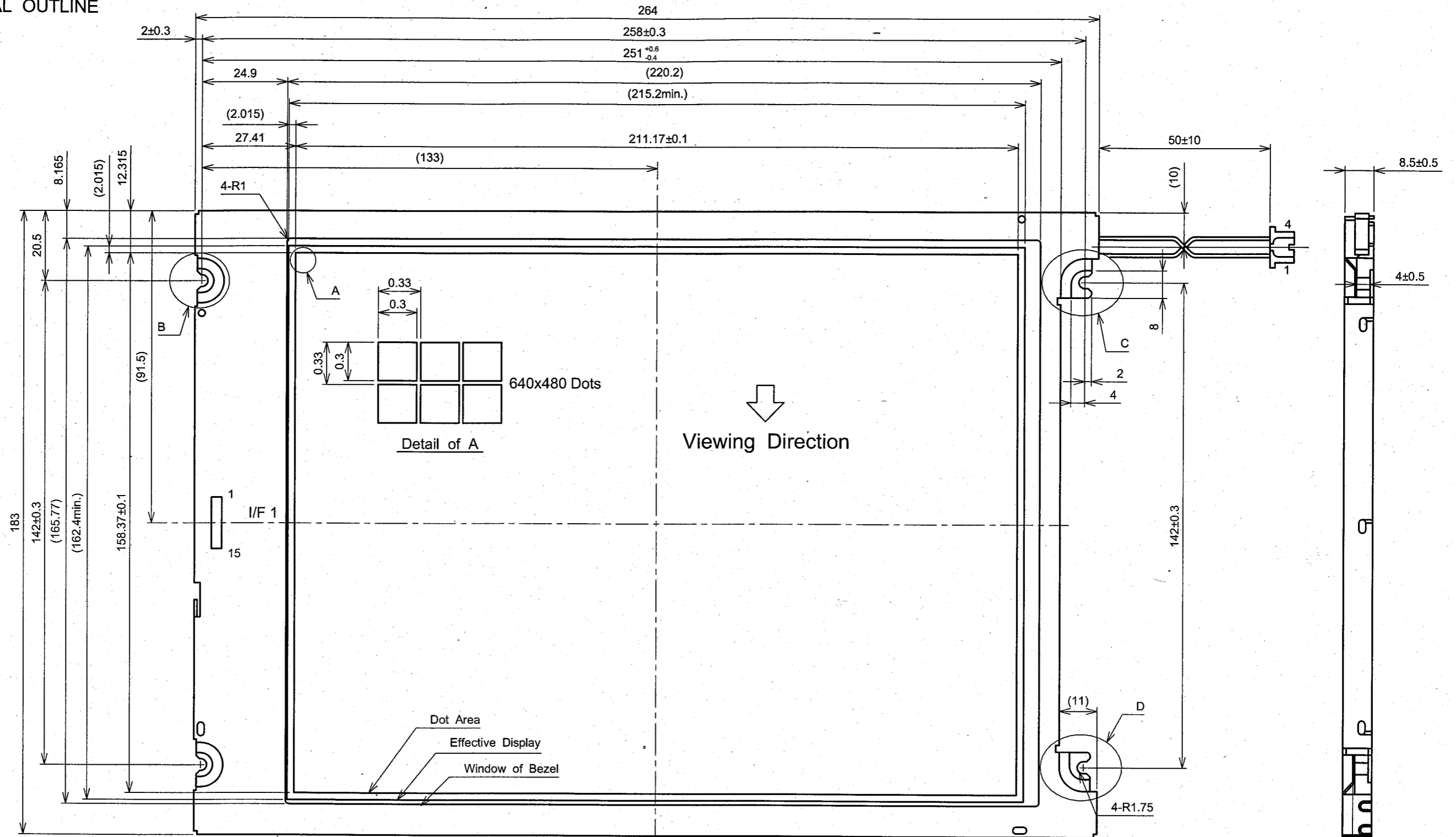

Detail of B

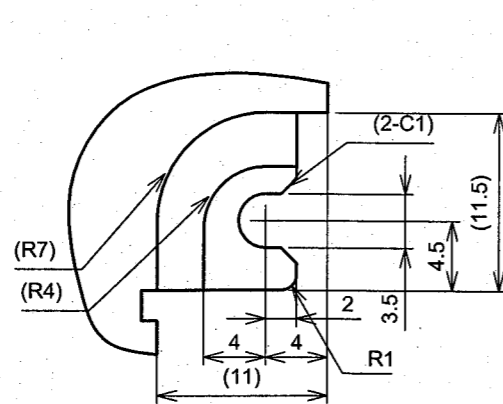

Detail of C

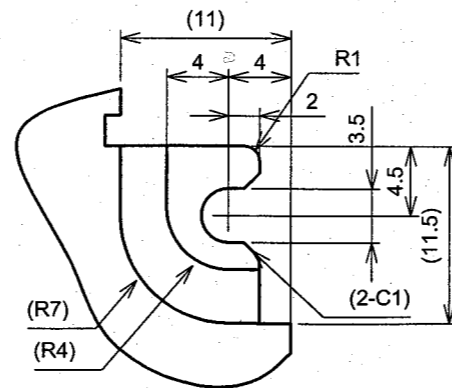

Detail of D

## 9.2 DISPLAY PATTERN

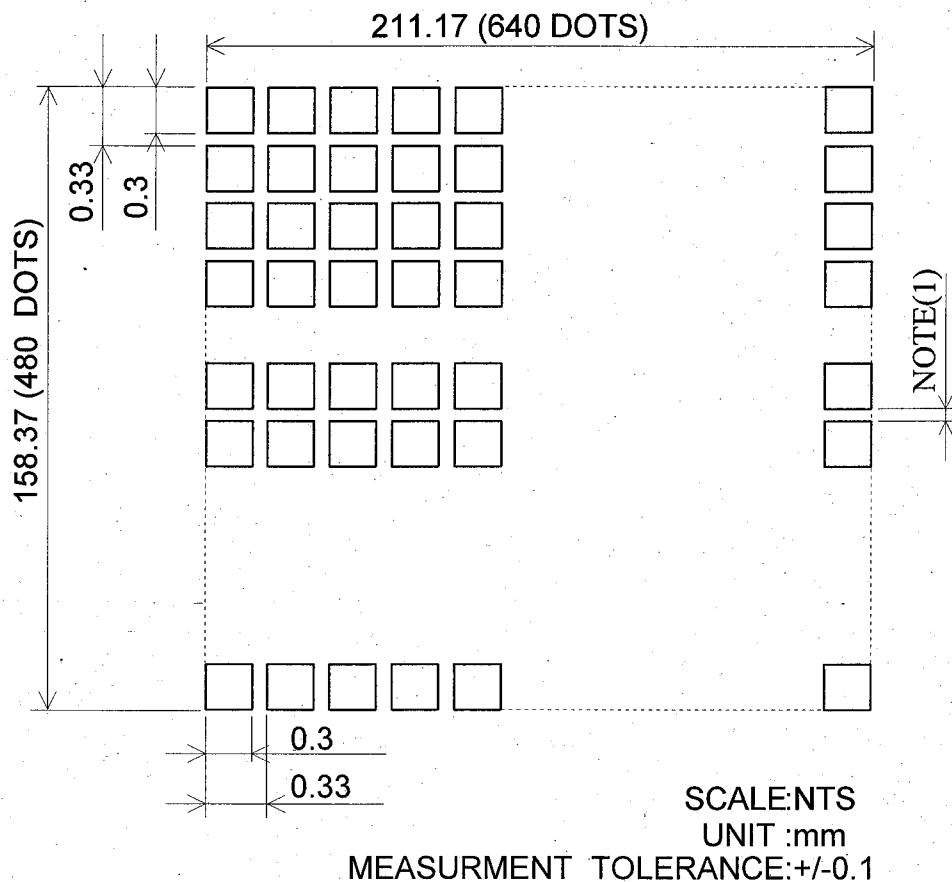

NOTE 1. CENTER-GAP 60 $\mu$ m MAX.

### 9.3 INTERNAL PIN CONNECTION

INTERFACE		PIN NO.	SIGNAL	LEVEL	FUNCTION
LCM	I/F1	1	FRAME	H	FIRST LINE MARKER
		2	LOAD	H→L	DATA LATCH
		3	CP	H→L	DATA SHIFT
		4	$\overline{\text{DISP.OFF}}$	H/L	H : ON / L : OFF
		5	VDD	-	POWER SUPPLY FOR LOGIC
		6	VSS	-	GND
		7	VEE	-	POWER SUPPLY FOR LC
		8	UD0	H/L	DISPLAY DATA (UPPER HALF)
		9	UD1		
		10	UD2		
		11	UD3		
		12	LD0	H/L	DISPLAY DATA (LOWER HALF)
		13	LD1		
		14	LD2		
		15	LD3		

I/F1 : MOLEX / 53261-1510  
 (SUITABLE CONNECTOR : MOLEX / 51021-1500)

INTERFACE		PIN NO.	SIGNAL	LEVEL	FUNCTION
CFL	CFL I/F	1	H.V	-	POWER SUPPLY FOR CFL
		2	N.C	-	-
		3	N.C	-	-
		4	GND	-	CFL GND

CFL I/F1 : JAE IL-G-4S-S3C2-SA

## 10. APPEARANCE STANDARD

### 10.1 APPEARANCE INSPECTION CONDITION

VISUAL INSPECTION SHOULD BE DONE UNDER THE FOLLOWING CONDITION.

- (1) IN THE DARK ROOM
- (2) WITH CFL PANEL LIGHTED WITH PRESCRIBED INVERTER CIRCUIT.
- (3) WITH EYES 25cm DISTANCE FROM LCM.
- (4) VIEWING ANGLE WITHIN 45 DEGREES FROM THE VERTICAL LINE TO THE CENTER OF LCD.

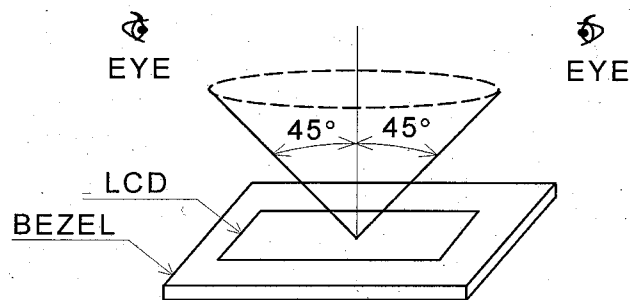

### 10.2 DEFINITION OF EACH ZONE

A ZONE : WITHIN THE EFFECTIVE DISPLAY AREA SPECIFIED AT PAGE 9-1/3 OF THIS DOCUMENT.

B ZONE : AREA BETWEEN THE WINDOW OF BEZEL LINE AND THE EFFECTIVE DISPLAY AREA LINE SPECIFIED AT PAGE 9-1/3 OF THIS DOCUMENT.

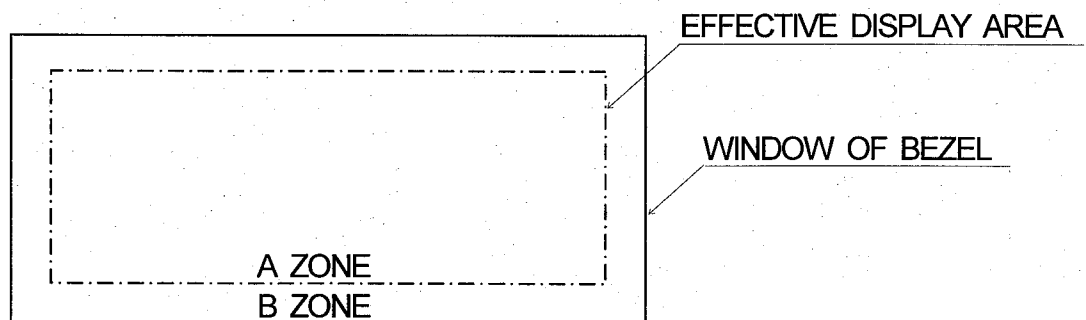



10.3 APPEARENCE SPECIFICATION

(1) LCD APPEARANCE

\*) IF THE PROBLEM OCCURES ABOUT THIS ITEM, THE RESPONSIBLE PERSON OF BOTH PARTY (CUSTOMER AND HITACHI) WILL DISCUSS MORE DETAIL.

No.	ITEM	CRITERIA		A	B	
	SCRATCHES	DISTINGUISHED ONE IS NOT ACCEPTABLE (TO BE JUDGED BY HITACHI STANDARD)		*	-	
	DENT	SAME AS ABOVE		*	-	
	WRINKLES IN POLARIZER	SAME AS ABOVE		*	-	
	BUBBLES	AVERAGE DIAMERET D(mm)	MAXIMUM NUMBER ACCEPTABLE	0	-	
		D<=0.3	IGNORED			
		0.3<D<=0.5	3			
		0.5<D<=1.0	1			
		1.0<D	NONE			
L C D	STAINS, FOREIGN MATERIALS	FILAMENTOUS			0	*
		LENGTH L(mm)	WIDTH W(mm)	MAXIMUM NUMBER ACCEPTABLE		
	DARK SPOT	L<=2.0	W<=0.03	IGNORED	0	*
		L<=2.0	0.03<W<=0.1	IGNORED		
		2.0<=L<=5.0	0.03<W<=0.1	9(10mm)		
		ROUND				
		AVERAGE DIAMETER D(mm)	MAXIMUM NUMBER ACCEPTABLE	MINIMUM SPACE	0	*
		D<0.25	IGNORED	-		
		0.25<=D<0.35	4	10mm		
		0.35<=D	NONE	30mm		
		THOSE WIPED OUT EASILY ARE ACCEPTABLE			0	0
		COLOR TONE	TO BE JUDGED BY HITACHI STANDARD		0	-
	COLOR UNIFORMITY	SAME AS ABOVE		0	-	
	PINHOLE	(A+B)/2<=0.15 MAXIMUM NUMBER : IGNORED		0	-	
		0.15<(A+B)/2<=0.3 MAXIMUM NUMBER : 10				
		C<=0.03 MAXIMUM NUMBER : IGNORED				

No.	ITEM	CRITERIA				A	B
L	CONTRAST IRREGULARITY (SPOT)	AVERAGE DIAMETER D(mm)	CONTRAST	MAXIMUM NUMBER ACCEPTABLE	MINIMUM SPACE	0	-
		$D \leq 0.3$	TO BE JUDGED	IGNORED	-		
		$0.3 < D \leq 0.45$	BY HITACHI	15	20mm		
		$0.45 < D \leq 0.6$	STANDARD	5	20mm		
		$0.6 < D \leq 0.8$		3	50mm		
		$0.8 < D$		NONE	-		
C D	CONTRAST IRREGULARITY (LINE) (A PAIR OF SCRATCH)	WIDTH W(mm)	LENGTH L(mm)	MAXIMUM NUMBER ACCEPTABLE	MINIMUM SPACE	0	-
		$W \leq 0.1$	$L \leq 3.0$	IGNORED	20mm		
		$0.1 < W \leq 0.15$	$L \leq 2.0$	3	20mm		
		$0.15 < W \leq 0.25$	$L \leq 1.5$	3	20mm		
		$0.25 < W \leq 0.35$	$L \leq 1.0$	3	20mm		
		$0.35 < W$	-	NONE	-		
	RUBBING SCRATCH	TO BE JUDGED BY HITACHI STANDRD					

(2) CFL BACKLIGHT APPEARANCE

No.	ITEM	CRITERIA			A	B
C F L	DARK SPOTS WHITE SPOT	AVERAGE DIAMETER D(mm)	MAXIMUM NUMBER ACCEPTABLE		0	-
	FOREIGN MATERIALS (SPOT)	$D \leq 0.4$	IGNORED			
		$0.4 < D$	NONE			
B A C K L I G H T	FOREIGN MATERIALS (LINE)	WIDTH W(mm)	LENGTH L(mm)	MAXIMUM NUMBER ACCEPTABLE	0	-
		$W < 0.2$	$L \leq 2.5$	1		
			$2.5 < L$	NONE		
	$0.2 < W$	-	NONE			
S C R A T C H E S	SCRATCHES	WIDTH W(mm)	LENGTH L(mm)	MAXIMUM NUMBER ACCEPTABLE	0	-
		$W \leq 0.1$	-	IGNORED		
		$0.1 \leq 0.2$	$L \leq 11.0$	1		
			$11.0 < L$	NONE		
$0.2 < W$	-	NONE				

**NOTE**

**(1) DEFINITION OF AVERAGE DIAMETER D**

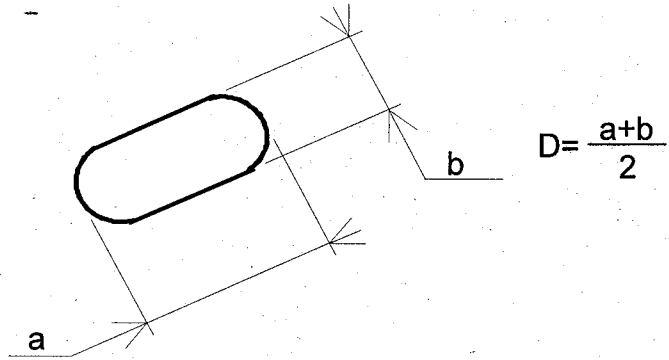

**(2) DEFINITION OF LENGTH L AND WIDTH W**

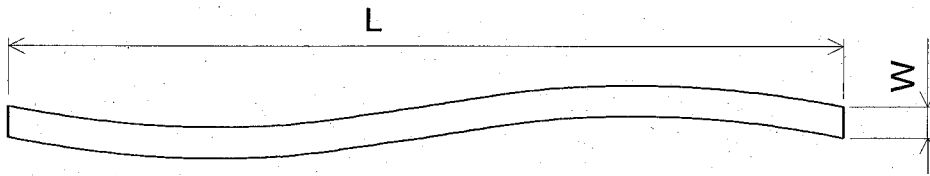

**(3) DEFINITION OF PINHOLE**

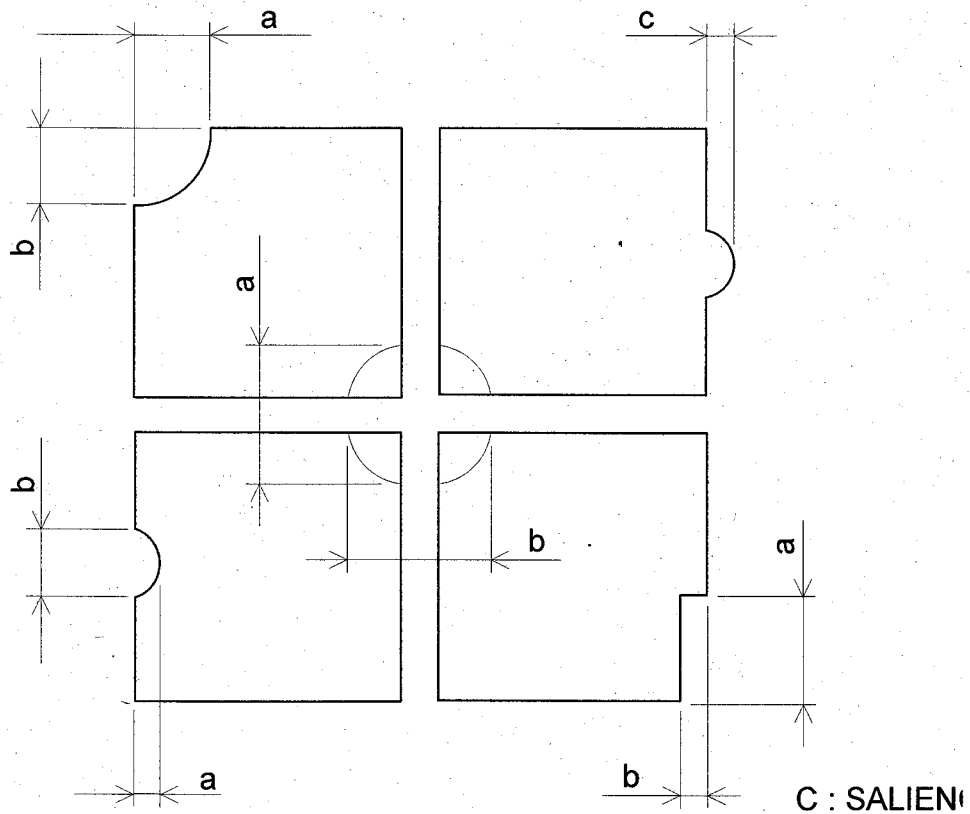

# 11. PRECAUTION IN DESIGN

## 11.1 MOUNTING METHOD

SINCE THE MODULE IS SO CONSTRUCTED AS TO BE FIXED BY UTILIZING FITTING HOLES IN THE MODULE AS SHOWN BELOW, IT IS NECESSARY TO TAKE CONSIDERATION THE FOLLOWING ITEMS ON ATTACHMENT TO A FRAME.

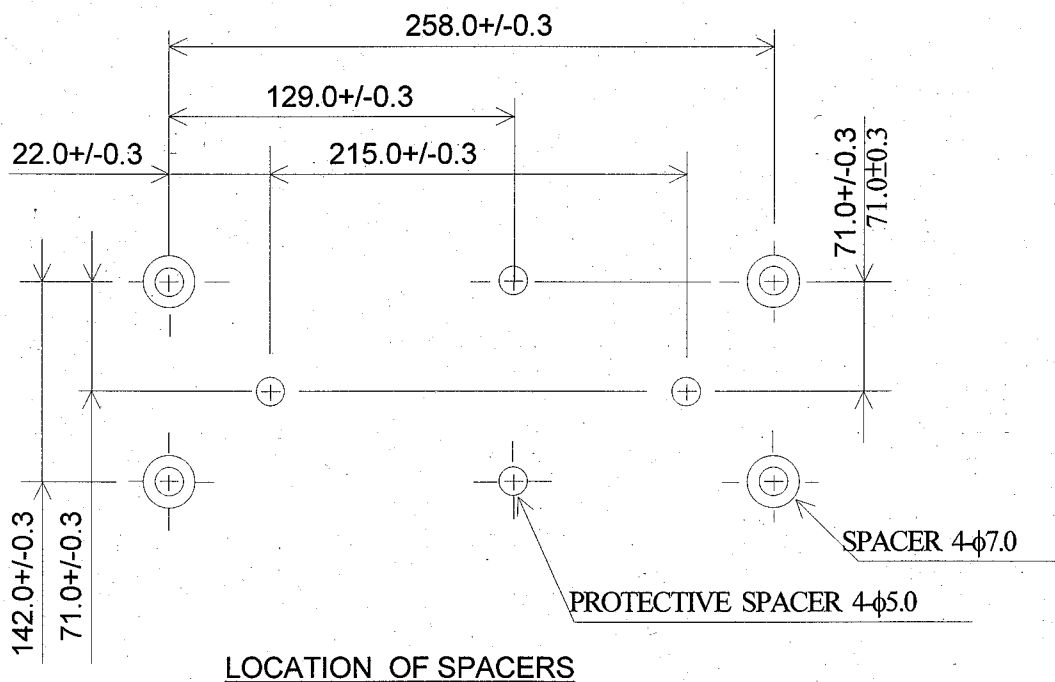
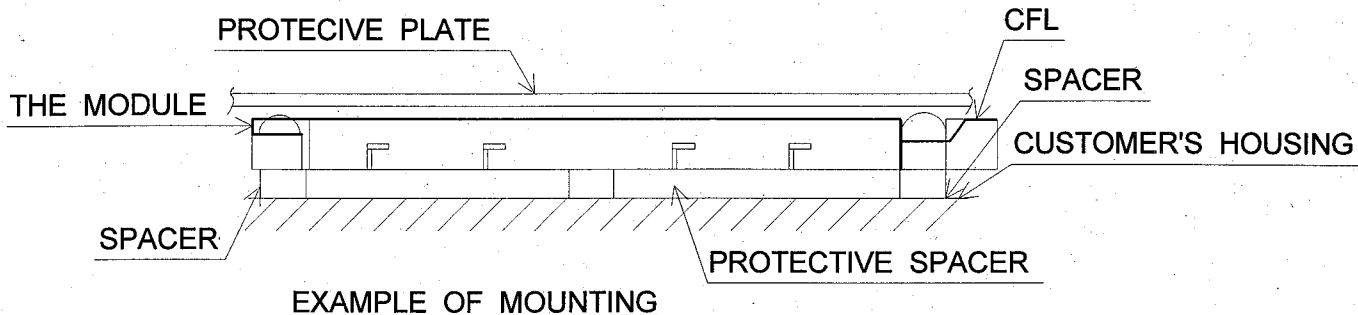

- (1) USE OF PROTECTIVE PLATE, MADE OF AN ACRYLIC PLATE, ETC, IN ORDER TO PROTECT A POLARIZER AND LC CELL.
- (2) TO PREVENT THE MODULE COVER FROM BEING PRESSED, THE SPACERS BETWEEN THE MODULE AND THE FITTING PLATES SHOULD BE LONGER THAN 0.5mm.
- (3) WE RECOMMEND YOU TO USE PROTECTIVE SPACER AS FIGURE FOR PROTECTING THE MODULE FROM ANY KIND OF SHOCK TO YOUR SET.

## 11.2 LC DRIVING VOLTAGE (VEE) AND VIEWING ANGLE RANGE.

SETTING VEE OUT OF THE RECOMMENDED CONDITION WILL BE A CAUSE FOR A CHANGE OF VIEWING ANGLE RANGE.

### 11.3 CAUTION AGAINST STATIC CHARGE

AS THIS MODULE IS PROVIDED WITH C-MOS LSI, THE CARE TO TAKE SUCH A PRECAUTION AS TO GROUNDING THE OPERATOR'S BODY IS REQUIRED WHEN HANDLING IT.

### 11.4 POWER ON SEQUENCE

INPUT SIGNALS SHOULD NOT BE APPLIED TO LCD MODULE BEFORE POWER SUPPLY VOLTAGE IS APPLIED AND REACHES TO SPECIFIED VOLTAGE (5+/-0.25V).

IF ABOVE SEQUENCE IS NOT KEPT, C-MOS LSIS OF LCD MODULES MAY BE DAMAGED DUE TO LATCH UP PROBLEM.

### 11.5 PACKAGING

- (1) NO. LEAVING PRODUCTS IS PREFERABLE IN THE PLACE OF HIGH HUMIDITY FOR A LONG PERIOD OF TIME. FOR THEIR STORAGE IN THE PLACE WHERE TEMPERATURE IS 35°C OR HIGHER, SPECIAL CARE TO PREVENT THEM FROM HIGH HUMIDITY IS REQUIRED. A COMBINATION OF HIGH TEMPERATURE AND HIGH HUMIDITY MAY CAUSE THEM POLARIZATION DEGRADATION AS WELL AS BUBBLE GENERATION AND POLARIZER PEEL-OFF. PLEASE KEEP THE TEMPERATURE AND HUMIDITY WITHIN THE SPECIFIED RANGE FOR USE AND STORING.
- (2) SINCE UPPER POLARIZERS AND LOWER ALUMINUM PLATES TEND TO BE EASILY DAMAGED, THEY SHOULD BE HANDLED WITH FULL CARE SO AS NOT TO GET THEM TOUCHED, PUSHED OR RUBBED BY A PIECE OF GLASS.  
TWEEZERS AND ANYTHING ELSE WHICH ARE HARDER THAN A PENCIL LEAD 3H.
- (3) AS THE ADHESIVES USED FOR ADHERING UPPER/LOWER POLARIZERS AND ALUMINUM PLATES ARE MADE OF ORGANIC SUBSTANCES WHICH WILL BE DETERIORATED BY A CHEMICAL REACTION WITH SUCH CHEMICALS AS ACETONE, TULUENE ETHANOLE AND ISOPROPYLALCOHOL. THE FOLLOWING SOLVENTS ARE RECOMMENDED FOR USE:

NORMAL HEXANE

PLEASE CONTACT US WHEN IT IS NECESSARY FOR YOU TO USE CHEMICALS OTHER THAN THE ABOVE.

- (4) LIGHTLY WIPE TO CLEAN THE DIRTY SURFACE WITH ABSORBENT COTTON WASTE OR OTHER SOFT MATERIAL LIKE CHAMOIS, SOAKED IN THE CHEMICALS RECOMMENDED WITHOUT SCRUBBING IT HARDLY. TO PREVENT THE DISPLAY SURFACE FROM DAMAGE AND KEEP THE APPEARANCE IN GOOD STATE, IT IS SUFFICIENT, IN GENERAL, TO WIPE IT WITH ABSORBENT COTTON.

- (5) IMMEDIATELY WIPE OFF ASLIVA OR WATER DROP ATTACHED ON THE DISPLAY AREA BECAUSE ITS LONG PERIOD ADHERANCE MAY CAUSE DEFORMATION OR FADED COLOR ON THE SPOT.
- (6) FOGY DEW DEPOSITED ON THE SURFACE AND CONTACT TERMINALS DUE TO COLDNESS WILL BE A CAUSE FOR POLARIZER DAMAGE, STAIN AND DIRT ON PRODUCT. WHEN NECESSARY TO TAKE OUT THE PRODUCTS FROM SOME PLACE AT LOW TEMPERATURE FOR TEST, ETC. IT IS REQUIRED FOR THEM TO BE WARMED UP IN A CONTAINER ONCE AT THE TEMPERATURE HIGHER THAN THAT OF ROOM.
- (7) TOUCHING THE DISPLAY AREA AND CONTACT TERMINALS WITH BARE HANDS AND CONTAMINATING THEM ARE PROHIBITED, BECAUSE THE STAIN ON THE DISPLAY AREA AND POOR INSULATION BETWEEN TERMINALS ARE OFTEN CAUSED BY BEING TOUCHED BY BARE HANDS.  
(THERE ARE SOME COSMETICS DETRIMENTAL TO POLARIZERS.)
- (8) IN GENERAL THE QUALITY OF GLASS IS FRAGILE SO THAT IT TENDS TO BE CRACKED OR CHIPPED IN HANDLING, SPECIALLY ON ITS PERIPHERY. PLEASE BE CAREFUL NOT TO GIVE IT SHARP SHOCK CAUSED BY DROPPING DOWN, ECT.

#### 11.6 CAUTION FOR OPERATION

- (1) IT IS AN INDISPENSABLE CONDITION TO DRIVE LCD'S WITHIN THE SPECIFIED VOLTAGE LIMIT SINCE THE HIGHER VOLTAGE THAN THE LIMIT CAUSES THE SHORTER LCD LIFE. AN ELECTROCHEMICAL REACTION DUE TO DIRECT CURRENT CAUSES LCD'S UNDESIRABLE DETERIORATION, SO THAT THE USE OF DIRECT CURRENT DRIVER SHOULD BE AVOIDED.
- (2) RESPONSE TIME WILL BE EXTREMELY DELAYED AT LOWER TEMPERATURE THAN THE OPERATING TEMPERATURE RANGE AND ON THE OTHER HAND AT HIGHER TEMPERATURE LCD'S SHOW DARK BULE COLOR IN THEM. HOWEVER THOSE PHENOMENA DO NOT MEAN INPEDIMENT OR OUT OF ORDER WITH LCD'S WHICH WILL COME BACK IN THE SPECIFIED OPERATING TEMPERATURE RANGE.
- (3) IF THE DISPLAY AREA IS PUSHED HARD DURING OPERATION, SOME FONT WILL BE ABNORMALLY DISPLAYED BUT IT RESUMES NORMAL CONDITION AFTER TURNING OFF ONCE.
- (4) A SLIGHT DEW DEPOSITING ON TERMINALS IS A CAUSE FOR ELECTROCHEMICAL REACTION RESULTING IN TERMINAL OPEN CIRCUIT. USAGE UNDER THE RELATIVE CONDITION OF 40°C 50%RH LESS IS REQUIRED.

### 11.7 STORAGE

IN CASE OF STORING FOR A LONG PERIOD OF TIME (FOR INSTANCE, FOR YEARS) FOR THE PURPOSE OF REPLACEMENT USE, THE FOLLOWING WAYS ARE RECOMMENDED.

- (1) STORAGE IN A POLYETHYLENE BAG WITH THE OPENING SEALED SO AS NOT TO ENTER FRESH AIR OUTSIDE IN IT, AND WITH NO DESICCANT.
- (2) PLACING IN A DARK PLACE WHERE NEITHER EXPOSURE TO DIRECT SUNLIGHT NOR LIGHT IS, KEEPING TEMPERATURE IN THE RANGE FROM 0°C TO 35°C.
- (3) STORING WITH NO TOUCH ON POLARIZER SURFACE BY ANYTHING ELSE.  
(IT IS RECOMMENDED TO STONE THEM AS THEY HAVE BEEN CONTAINED IN THE INNER CONTAINER AT THE TIME OF DELIVERY FROM US.)

### 11.8 SAFETY

- (1) IT IS RECOMMENDABLE TO CRASH DAMAGED OR UNNECESSARY LCD'S INTO PIECES AND WASH OFF LIQUID CRYSTAL BY EITHER OF SOLVENTS SUCH AS ACETONE AND ETHANOL, WHICH SHOULD BE BURNED UP LATER.
- (2) WHEN ANY LIQUID LEAKED OUT OF A DAMAGED GLASS GALL COMES IN CONTACT WITH YOUR HANDS, PLEASE WASH IT OFF WELL WITH SOAP AND WATER.



## 12. DESIGNATION OF LOT MARK

### 12.1 LOT MARK

LOT MARK IS CONSISTED OF 4 DIGITS FOR PRODUCTION.

LOT AND 6 DIGITS FOR PRODUCTION CONTROL.

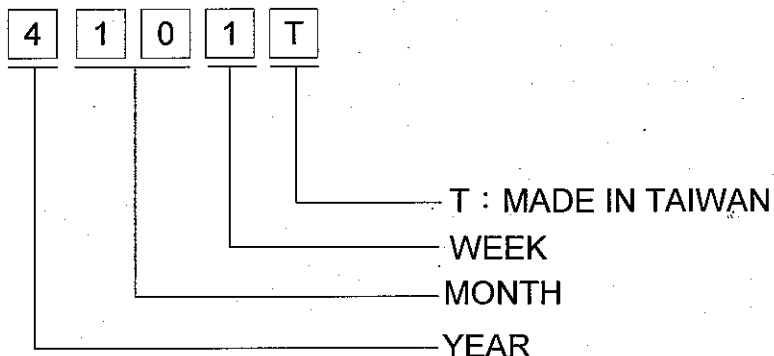

YEAR	FIGURE IN LOT MARK
2007	7
2008	8
2009	9
2010	0
2011	1

MONTH	FIGURE IN LOT MARK	MONTH	FIGURE IN LOT MARK
JAN.	01	JULY.	07
FEB.	02	AUG.	08
MAR.	03	SEPT.	09
APR.	04	OCT.	10
MAY.	05	NOV.	11
JUNE.	06	DEC.	12

WEEK (DAY IN CALENDAR)	FIGURE IN LOT MARK
1~7	1
8~14	2
15~21	3
22~28	4
29~31	5

### 12.2 REVISION

REV No.	ITEM	LOT No.
B	CFL I/F Connector : Mitsumi M63M83 - 04	-
C	CFL I/F Connector : JAE IL-G-4S-S3C2-SA	7102T

### 12.3 LOCATION OF LOT MARK

on the back side of LCM

4 1 0 1 \* \* \* \* \*

### 13. PRECAUTION FOR USE

- (1) A LIMIT SAMPLE SHOULD BE PROVIDED BY THE BOTH PARTIES ON AN OCCASION WHEN THE BOTH PARTIES AGREED ITS NECESSITY. JUDGEMENT BY A LIMIT SAMPLE SHALL TAKE EFFECT AFTER THE LIMIT SAMPLE HAS BEEN ESTABLISHED AND CONFIRMED BY THE BOTH PARTIES.
- (2) ON THE FOLLOWING OCCASIONS, THE HANDLING OF THE PROBLEM SHOULD BE DECIDED THROUGH DISCUSSION AND AGREEMENT BETWEEN RESPONSIBLE PERSONS OF THE BOTH PARTIES.
  - (1) WHEN A QUESTION IS ARISEN IN THE SPECIFICATIONS.
  - (2) WHEN A NEW PROBLEM IN ARISEN WHICH IS NOT SPECIFIED IN THIS SPECIFICATIONS.
  - (3) WHEN AN INSPECTION SPECIFICATIONS CHANGE OR OPERATING CONDITION CHANGE IN CUSTOMER IS REPORTED TO HITACHI, AND SOME PROBLEM IS ARISEN IN THIS SPECIFICATION DUE TO THE CHANGE.
  - (4) WHEN A NEW PROBLEM IS ARISEN AT THE CUSTOMER'S OPERATING SET FOR SAMPLE EVALUATION IN THE CUSTOMER SITE.
- (3) REGARDING THE TREATMENT FOR MAINTENANCE AND REPAIRING, BOTH PARTIES WILL DISCUSS IT IN SIX MONTHS LATER AFTER LATEST DELIVERY OF THIS PRODUCT.

THE PRECAUTION THAT SHOULD BE OBSERVED WHEN HANDLING LCM HAVE BEEN EXPLAINED ABOVE. IF ANY POINTS ARE UNCLEAR OF IF YOU HAVE ANY REQUESTS, PLEASE CONTACT HITACHI.