

LMH6570

2:1 High Speed Video Multiplexer

General Description

The LMH™6570 is a high performance analog multiplexer optimized for professional grade video and other high fidelity high bandwidth analog applications. The output amplifier selects one of two buffered input signals based on the state of the SEL pin. The LMH6570 provides a 400 MHz bandwidth at 2 V_{PP} output signal levels. Multimedia and high definition television (HDTV) applications can benefit from the LMH6570's 0.1 dB bandwidth of 150 MHz and its 2200 V/μs slew rate.

The LMH6570 supports composite video applications with its 0.02% and 0.05° differential gain and phase errors for NTSC and PAL video signals while driving a single, back terminated 75Ω load. An 80 mA linear output current is available for driving multiple video load applications.

The LMH6570 gain is set by external feedback and gain set resistors for maximum flexibility.

The LMH6570 is available in the 8 pin SOIC package.

Features

- 500 MHz, 500 mV_{PP}, -3 dB bandwidth, A_V=2
- 400 MHz, 2V_{PP}, -3 dB bandwidth, A_V=2
- 8 ns channel switching time
- 70 dB channel to channel isolation @ 10 MHz
- 0.02%, 0.05° diff. gain, diff. phase
- 0.1 dB gain flatness to 150 MHz
- 2200 V/μs slew rate
- Wide supply voltage range: 6V (±3V) to 12V (±6V)
- -68 dB HD2 @ 5 MHz
- -84 dB HD3 @ 5 MHz

Applications

- Video router
- Multi input video monitor
- Instrumentation / Test equipment
- Receiver IF diversity switch
- Multi channel A/D driver
- Picture in Picture video switch

Connection Diagram

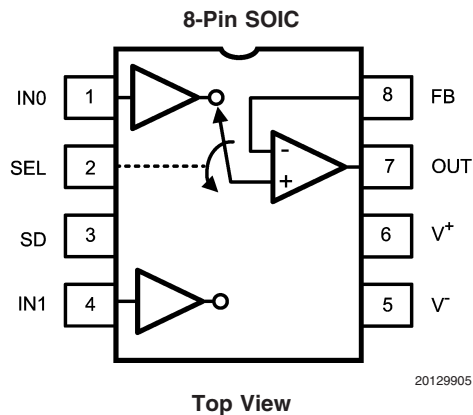

Truth Table

SEL	SD	OUTPUT
1	0	IN1 * (1+RF/RG)
0	0	IN0 * (1+RF/RG)
X	1	Shutdown

LMH™ is a trademark of National Semiconductor Corporation.

Absolute Maximum Ratings (Note 1)

If Military/Aerospace specified devices are required, please contact the National Semiconductor Sales Office/Distributors for availability and specifications.

ESD Tolerance	(Note 4)
Human Body Model	2000V
Machine Model	200V
Supply Voltage ($V^+ - V^-$)	13.2V
I_{OUT} (Note 3)	130 mA
Signal & Logic Input Pin Voltage	$\pm(V_S+0.6V)$
Signal & Logic Input Pin Current	± 20 mA
Maximum Junction Temperature	+150°C

Storage Temperature Range	-65°C to +150°C
Soldering Information	
Infrared or Convection (20 sec)	235 °C
Wave Soldering (10 sec)	260 °C

Operating Ratings (Note 1)

Operating Temperature	-40 °C to 85 °C
Supply Voltage Range	6V to 12V

Thermal Resistance

Package	(θ_{JA})	(θ_{JC})
8-Pin SOIC	150°C/W	50°C/W

 $\pm 5V$ Electrical Characteristics

$V_S = \pm 5V$, $R_L = 100\Omega$, $R_F = 576\Omega$, $A_V = 2$ V/V, $T_J = 25$ °C, Unless otherwise specified. **Bold** numbers specify limits at temperature extremes.

Symbol	Parameter	Conditions (Note 2)	Min (Note 5)	Typ (Note 9)	Max (Note 5)	Units
Frequency Domain Performance						
SSBW	-3 dB Bandwidth	$V_{OUT} = 0.5 V_{PP}$		500		MHz
LSBW	-3 dB Bandwidth	$V_{OUT} = 2 V_{PP}$		400		MHz
.1 dBBW	0.1 dB Bandwidth	$V_{OUT} = 0.25 V_{PP}$		150		MHz
DG	Differential Gain	$R_L = 150\Omega$, $f = 4.43$ MHz		0.02		%
DP	Differential Phase	$R_L = 150\Omega$, $f = 4.43$ MHz		0.05		deg
XTLK	Channel to Channel Crosstalk	All Hostile, $f = 5$ MHz		-70		dBc
Time Domain Response						
TRS	Channel to Channel Switching Time	Logic transition to 90% output		8		ns
	Enable and Disable Times	Logic transition to 90% or 10% output.		10		ns
TRL	Rise and Fall Time	4V Step		2.4		ns
TSS	Settling Time to 0.05%	2V Step		17		ns
OS	Overshoot	2V Step		5		%
SR	Slew Rate	4V Step, (Note 8)		2200		V/ μ s
Distortion						
HD2	2 nd Harmonic Distortion	2 V_{PP} , 5 MHz		-68		dBc
HD3	3 rd Harmonic Distortion	2 V_{PP} , 5 MHz		-84		dBc
IMD	3 rd Order Intermodulation Products	10 MHz, Two tones 2 Vpp at output		-80		dBc
Equivalent Input Noise						
VN	Voltage	>1 MHz, Input Referred		5		nV \sqrt{Hz}
ICN	Current	>1 MHz, Input Referred		5		pA \sqrt{Hz}
Static, DC Performance						
CHGM	Channel to Channel Gain Difference	DC, Difference in gain between channels		± 0.005	± 0.034 ± 0.036	%
VIO	Input Offset Voltage	$V_{IN} = 0V$		1	± 15 ± 21	mV
DVIO	Offset Voltage Drift (Note 10)			30		$\mu V/^\circ C$
IBN	Input Bias Current (Note 7)	$V_{IN} = 0V$		-3	± 5.5 ± 6.2	μA
DIBN	Bias Current Drift (Note 10)			11		nA/ $^\circ C$
IBI	Inverting Input Bias Current (Note 7)	Pin 8, Feedback point, $V_{IN} = 0V$		-3	± 18 ± 22	μA
PSRR	Power Supply Rejection Ratio	DC, Input referred	48 46	50		dB

±5V Electrical Characteristics (Continued)

$V_S = \pm 5V$, $R_L = 100\Omega$, $R_F = 576\Omega$, $A_V = 2 V/V$, $T_J = 25^\circ C$, Unless otherwise specified. **Bold** numbers specify limits at temperature extremes.

Symbol	Parameter	Conditions (Note 2)	Min (Note 5)	Typ (Note 9)	Max (Note 5)	Units
ICC	Supply Current	No Load, Shutdown Pin (SD) > 0.8V		13.8	15 16	mA
	Supply Current Shutdown	Shutdown Pin (SD) > 2V		1.1	1.3 1.4	mA
VIH	Logic High Threshold	Select Pin & Shutdown pin (SEL, SD)	2.0			V
VIL	Logic Low Threshold	Select Pin & Shutdown pin (SEL, SD)			0.8	V
II _L	Logic Pin Input Current Low (Note 7)	Logic Input = 0V Select Pin & Shutdown pin (SEL, SD)	-2.9 -10	-1		μA
II _H	Logic Pin Input Current High (Note 7)	Logic Input = 5.0V, Select Pin & Shutdown pin (SEL, SD)		57	68 75	μA
Miscellaneous Performance						
RIN+	Input Resistance			5		k Ω
CIN	Input Capacitance			0.8		pF
ROUT	Output Resistance	Output Active, (SD < 0.8V)		0.04		Ω
ROUT	Output Resistance	Output Disabled, (SD > 2V)		3000		Ω
COU _T	Output Capacitance	Output Disabled, (SD > 2V)		3.1		pF
VO	Output Voltage Range	No Load	± 3.51 ± 3.50	± 3.7		V
VOL		$R_L = 100\Omega$	± 3.16 ± 3.15	± 3.5		V
CMIR	Input Voltage Range		± 2.5	± 2.6		V
IO	Linear Output Current (Note 7)	$V_{IN} = 0V$,	+60 -70 ± 55	± 80		mA
ISC	Short Circuit Current (Note 3)	$V_{IN} = \pm 2V$, Output shorted to ground		± 230		mA

±3.3V Electrical Characteristics

$V_S = \pm 3.3V$, $R_L = 100\Omega$, $R_F = 576\Omega$, $A_V = 2 V/V$; Unless otherwise specified.

Symbol	Parameter	Conditions (Note 2)	Min (Note 5)	Typ (Note 9)	Max (Note 5)	Units
Frequency Domain Performance						
SSBW	-3 dB Bandwidth	$V_{OUT} = 0.5 V_{PP}$		475		MHz
LSBW	-3 dB Bandwidth	$V_{OUT} = 2.0 V_{PP}$		375		MHz
0.1 dBBW	0.1 dB Bandwidth	$V_{OUT} = 0.5 V_{PP}$		100		MHz
GFP	Peaking	DC to 200 MHz		0.4		dB
XTLK	Channel to Channel Crosstalk	All Hostile, $f = 5$ MHz		-70		dBc
Time Domain Response						
TRL	Rise and Fall Time	2V Step		2		ns
TSS	Settling Time to 0.05%	2V Step		20		ns
OS	Overshoot	2V Step		5		%
SR	Slew Rate	2V Step		1400		V/ μs
Distortion						
HD2	2 nd Harmonic Distortion	2 V_{PP} , 10 MHz		-67		dBc
HD3	3 rd Harmonic Distortion	2 V_{PP} , 10 MHz		-87		dBc
Static, DC Performance						

±3.3V Electrical Characteristics (Continued) $V_S = \pm 3.3V$, $R_L = 100\Omega$, $R_F = 576\Omega$, $A_V = 2$ V/V; Unless otherwise specified.

Symbol	Parameter	Conditions (Note 2)	Min (Note 5)	Typ (Note 9)	Max (Note 5)	Units
VIO	Input Offset Voltage	$V_{IN} = 0V$		1		mV
IBN	Input Bias Current (Note 7)	$V_{IN} = 0V$		-3		μA
PSRR	Power Supply Rejection Ratio	DC, Input Referred		49		dB
ICC	Supply Current	No Load		12.5		mA
VIH	Logic High Threshold	Select Pin & Shutdown pin (SEL, SD), $V_{IH} \cong V^+ * 0.4$		1.3		V
VIL	Logic Low Threshold	Select Pin & Shutdown pin (SEL, SD), $V_{IL} \cong V^+ * 0.12$		0.4		V

Miscellaneous Performance

RIN+	Input Resistance			5		k Ω
CIN	Input Capacitance			0.8		pF
ROUT	Output Resistance			0.06		Ω
VO	Output Voltage Range	No Load		± 2		V
VOL		$R_L = 100\Omega$		± 1.8		V
CMIR	Input Voltage Range			± 1.2		V
IO	Linear Output Current (Note 3)	$V_{IN} = 0V$		± 60		mA
ISC	Short Circuit Current (Note 3)	$V_{IN} = \pm 1V$, Output shorted to ground		± 150		mA

Note 1: Absolute Maximum Ratings indicate limits beyond which damage to the device may occur. Operating Ratings indicate conditions for which the device is intended to be functional, but specific performance is not guaranteed. For guaranteed specifications, see the Electrical Characteristics tables.

Note 2: Electrical Table values apply only for factory testing conditions at the temperature indicated. Factory testing conditions result in very limited self-heating of the device such that $T_J = T_A$. No guarantee of parametric performance is indicated in the electrical tables under conditions of internal self heating where $T_J > T_A$. See Applications Section for information on temperature de-rating of this device. Min/Max ratings are based on product testing, characterization and simulation. Individual parameters are tested as noted.

Note 3: The maximum output current (I_{OUT}) is determined by the device power dissipation limitations (The junction temperature cannot be allowed to exceed 150°C). See the Power Dissipation section of the Application Section for more details. A short circuit condition should be limited to 5 seconds or less.

Note 4: Human Body model, 1.5k Ω in series with 100pF. Machine model, 0 Ω in series with 200pF

Note 5: Limits are 100% production tested at 25°C. Limits over the operating temperature range are guaranteed through correlation using Statistical Quality Control (SQC) methods.

Note 6: Parameter guaranteed by design.

Note 7: Positive Value is current into device.

Note 8: Slew Rate is the average of the rising and falling edges.

Note 9: Typical numbers are the most likely parametric norm.

Note 10: Drift determined by dividing the change in parameter at temperature extremes by the total temperature change.

Ordering Information

Package	Part Number	Package Marking	Transport Media	NSC Drawing
8-Pin SOIC	LMH6570MA	LMH6570MA	95 Units/Rail	M08A
	LMH6570MAX		2.5k Units Tape and Reel	

Typical Performance Characteristics $V_S = \pm 5V$, $R_L = 100\Omega$, $A_V=2$, $R_F=R_G=576\Omega$; unless otherwise specified.

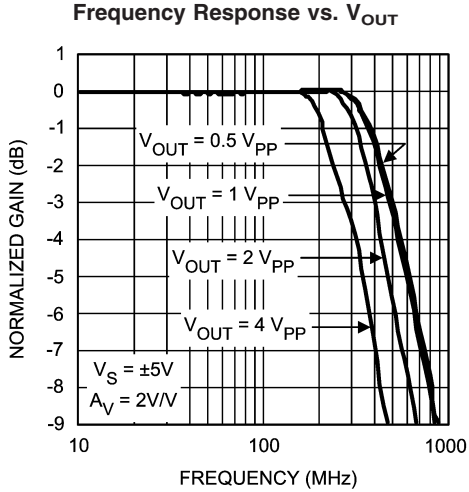

20129902

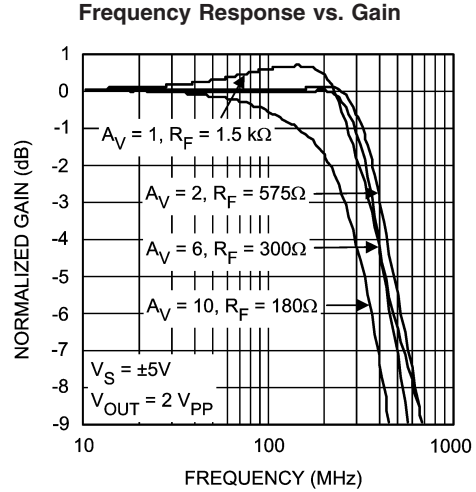

20129903

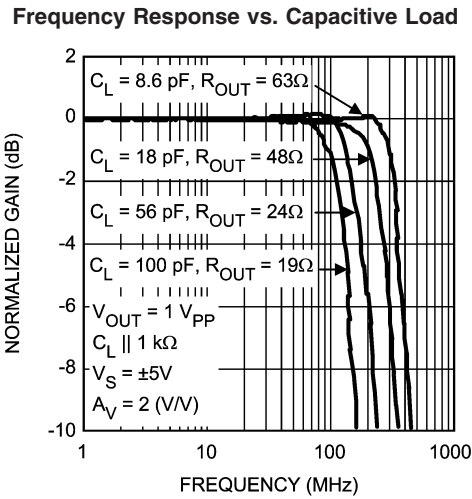

20129914

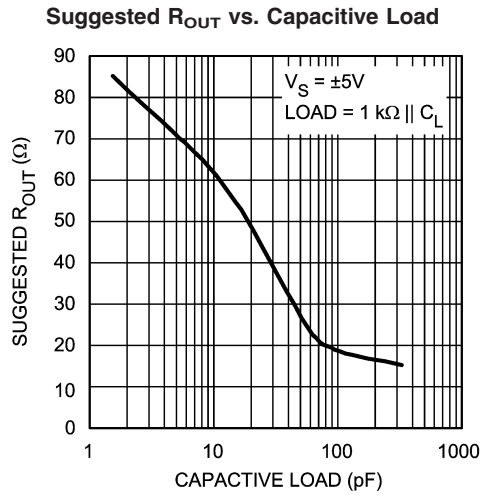

20129915

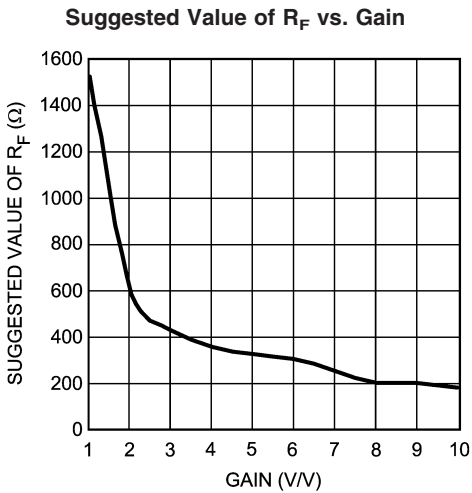

20129901

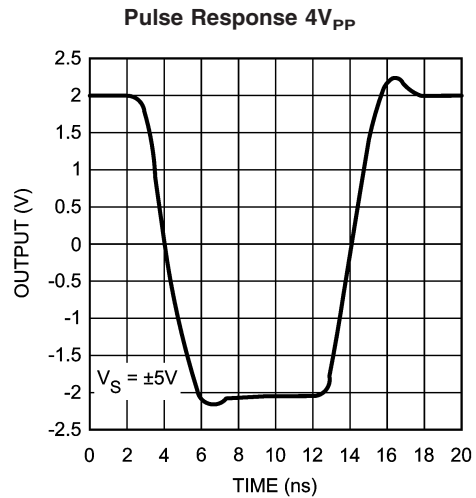

20129925

Typical Performance Characteristics $V_S = \pm 5V$, $R_L = 100\Omega$, $A_V=2$, $R_F=R_G=576\Omega$; unless otherwise specified. (Continued)

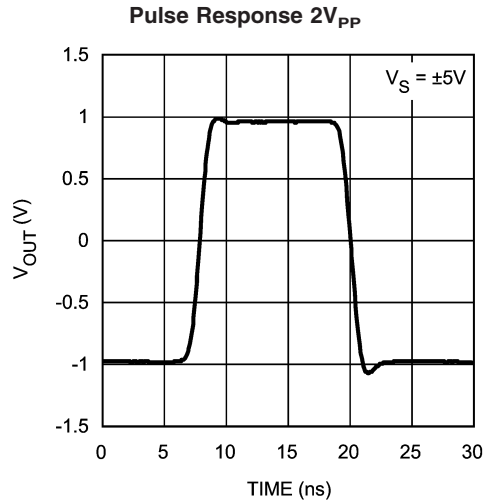

20129929

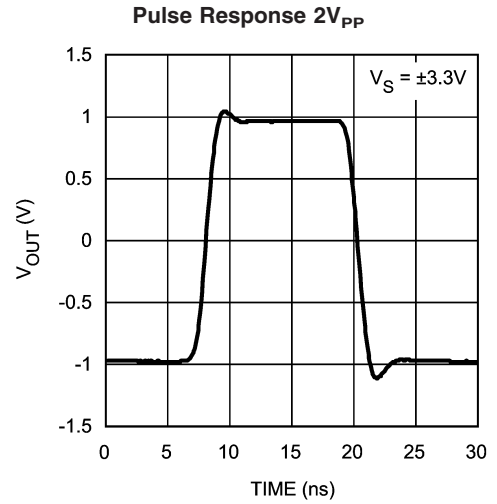

20129930

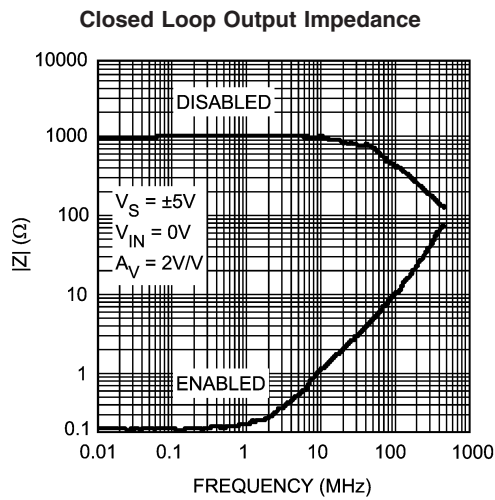

20129908

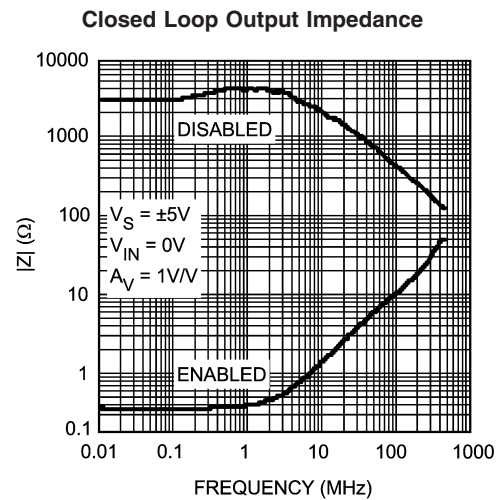

20129909

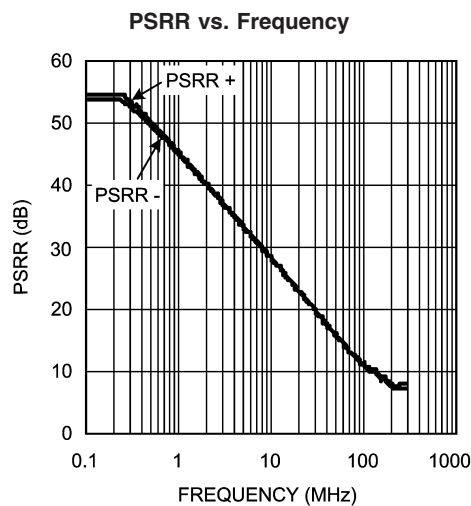

20129904

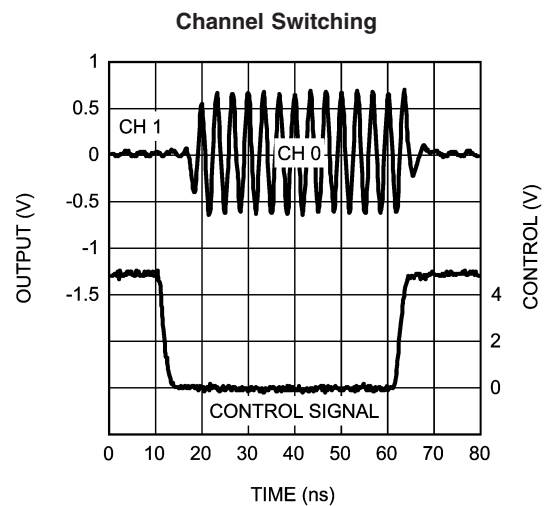

20129916

Typical Performance Characteristics $V_s = \pm 5V$, $R_L = 100\Omega$, $A_V=2$, $R_F=R_G=576\Omega$; unless otherwise specified. (Continued)

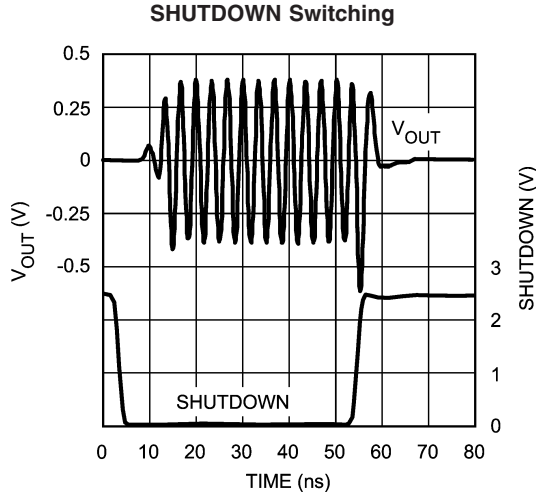

20129921

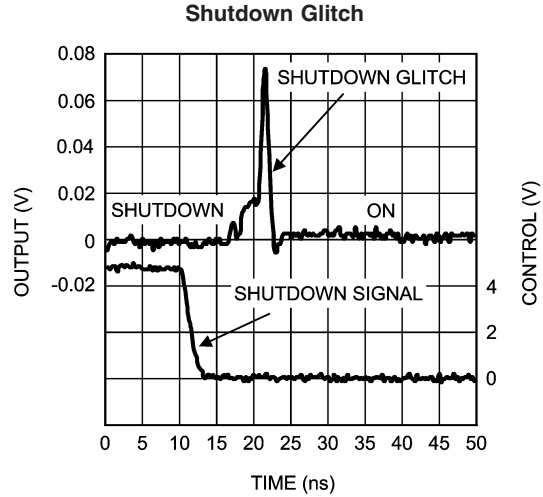

20129927

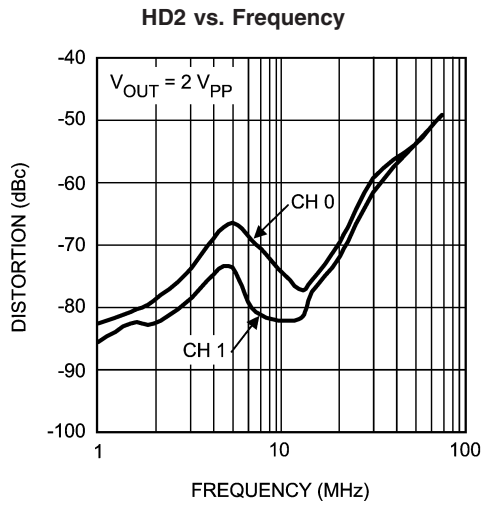

20129933

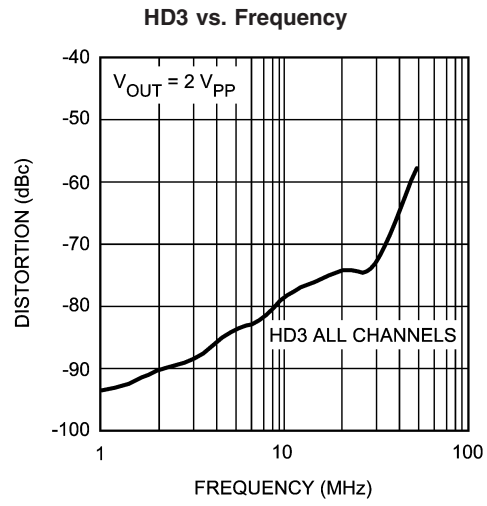

20129934

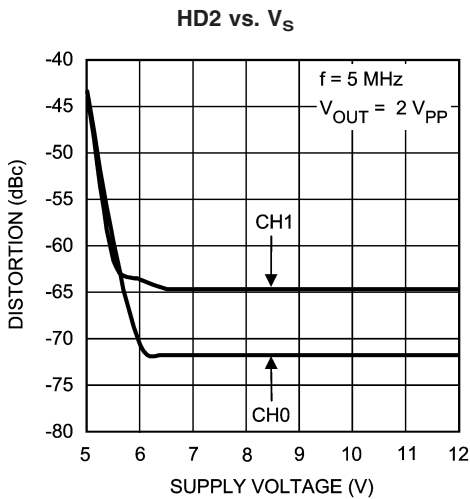

20129907

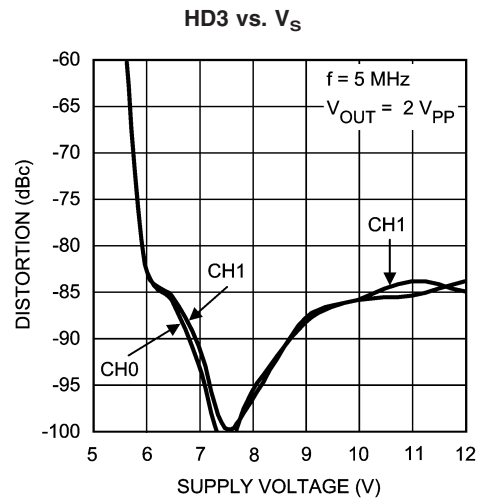

20129910

Typical Performance Characteristics $V_s = \pm 5V$, $R_L = 100\Omega$, $A_V=2$, $R_F=R_G=576\Omega$; unless otherwise specified. (Continued)

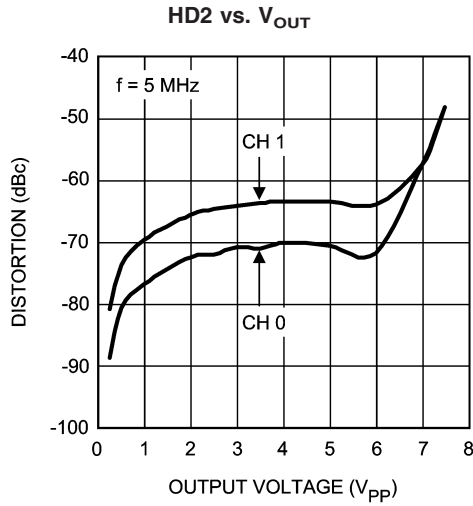

20129911

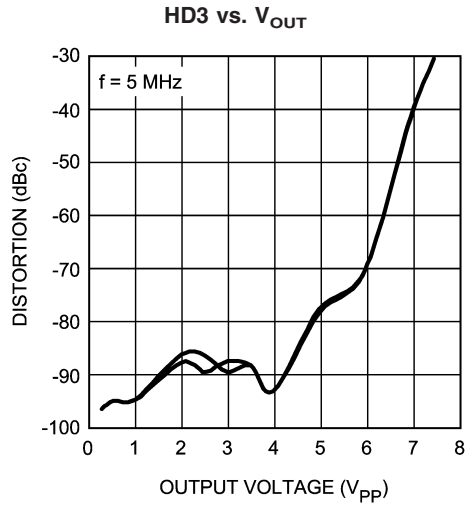

20129906

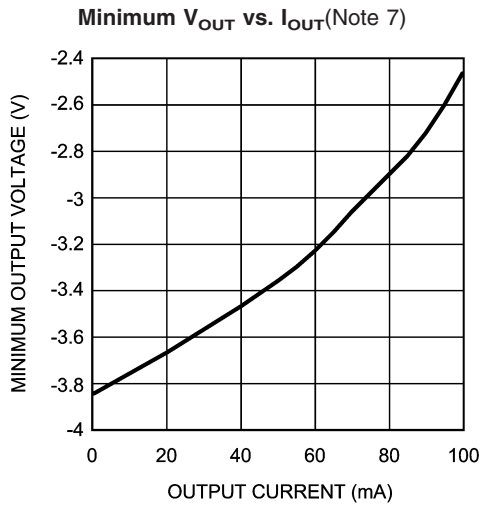

20129912

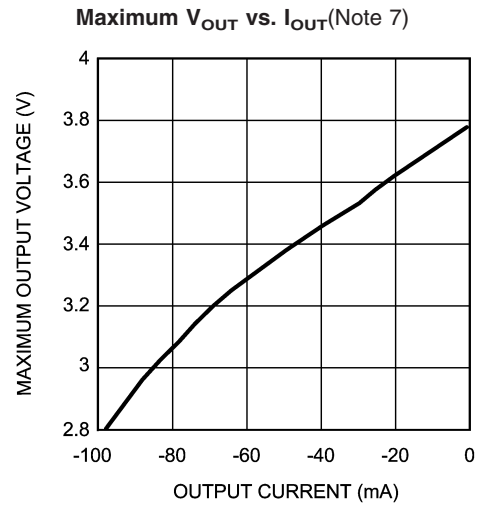

20129913

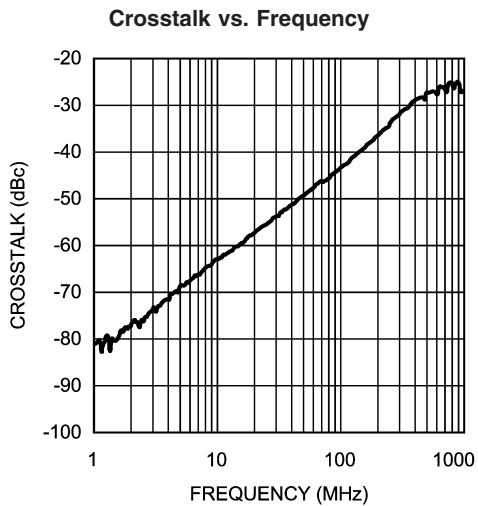

20129935

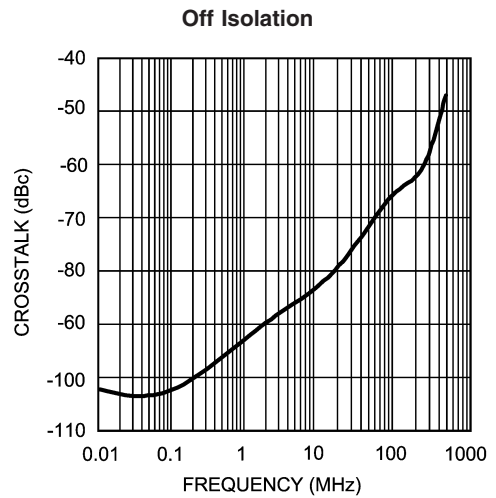

20129931

Application Notes

GENERAL INFORMATION

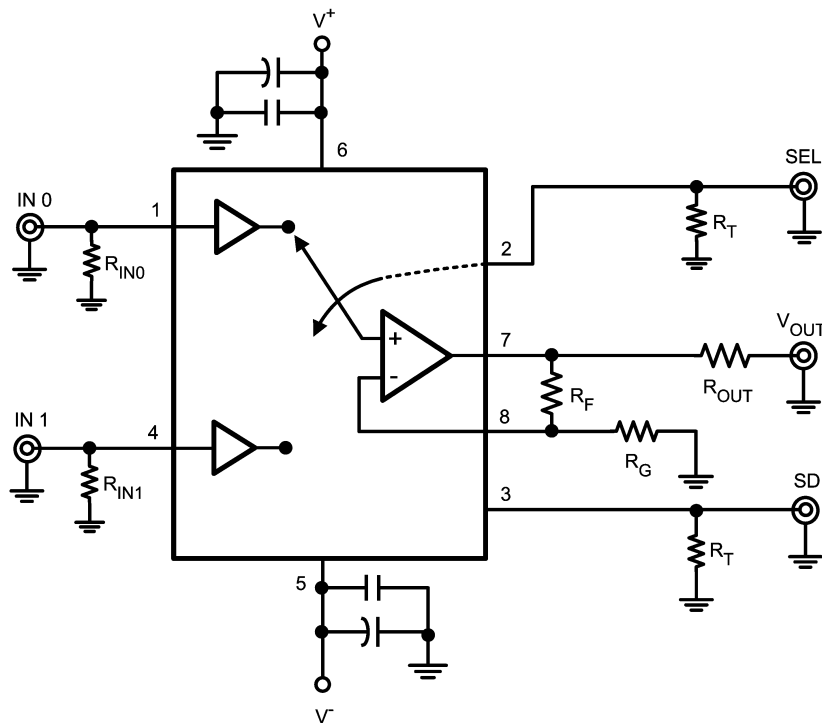

20129922

FIGURE 1. Typical Application

The LMH6570 is a high-speed 2:1 analog multiplexer, optimized for very high speed and low distortion. With selectable gain and excellent AC performance, the LMH6570 is ideally suited for switching high resolution, presentation grade video signals. The LMH6570 has no internal ground reference. Single or split supply configurations are both possible, however, all logic functions are referenced to the mid supply point. The LMH6570 features very high speed channel switching and disable times. When disabled the LMH6570 output is high impedance making MUX expansion possible by combining multiple devices. See "Multiplexer Expansion" section below. The LMH6570 SEL defaults to logic low (IN0 active). The default state for the SD pin is also logic low (device enabled). Both pins can be left floating if the default state is desired.

VIDEO PERFORMANCE

The LMH6570 has been designed to provide excellent performance with production quality video signals in a wide variety of formats such as HDTV and High Resolution VGA. Best performance will be obtained with back-terminated loads. The back termination reduces reflections from the transmission line and effectively masks transmission line and other parasitic capacitances from the amplifier output stage. *Figure 1* shows a typical configuration for driving a 75Ω cable. The output buffer is configured for a gain of 2, so using back terminated loads will give a net gain of 1.

FEEDBACK RESISTOR SELECTION

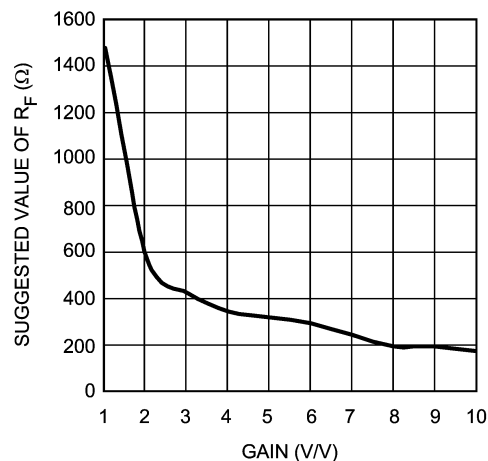

20129932

FIGURE 2. Suggested R_F vs. Gain

The LMH6570 has a current feedback output buffer with gain determined by external feedback (R_F) and gain set (R_G) resistors. With current feedback amplifiers, the closed loop frequency response is a function of R_F . For a gain of 2 V/V, the recommended value of R_F is 576Ω. For other gains see the chart "Suggested R_F vs Gain". Generally, lowering R_F from the recommended value will peak the frequency re-

Application Notes (Continued)

sponse and extend the bandwidth while increasing the value of R_F will cause the frequency response to roll off faster. Reducing the value of R_F too far below the recommended value will cause overshoot, ringing and, eventually, oscillation.

Since all applications are slightly different it is worth some experimentation to find the optimal R_F for a given circuit. For more information see Application Note OA-13 which describes the relationship between R_F and closed-loop frequency response for current feedback operational amplifiers. The impedance looking into pin 8 is approximately 20Ω . This allows for good bandwidth at gains up to 10 V/V. When used with gains over 10 V/V, the LMH6570 will exhibit a "gain bandwidth product" similar to a typical voltage feedback amplifier. For gains of over 10 V/V consider selecting a high performance video amplifier like the LMH6720 to provide additional gain.

EVALUATION BOARDS

National Semiconductor provides the following evaluation boards as a guide for high frequency layout and as an aid in device testing and characterization. Many of the data sheet plots were measured with this board.

Device	Package	Evaluation Board
LMH6570	SOIC	LMH730277

An evaluation board can be shipped when a sample request is placed with National Semiconductor. Samples can be ordered on the National web page. (www.national.com)

MULTIPLEXER EXPANSION

With the SHUTDOWN pin putting the output stage into a high impedance state, several LMH6570's can be tied together to form a larger input MUX. However, there is a

loading effect on the active output caused by the unselected devices. The circuit in *Figure 3* shows how to compensate for this effect. For the 8:1 MUX function shown in *Figure 3* below the gain error would be about 0.7% or -0.06dB . In the circuit in *Figure 3*, resistor ratios have been adjusted to compensate for this gain error. By adjusting the gain of each multiplexer circuit the error can be reduced to the tolerance of the resistors used (1% in this example).

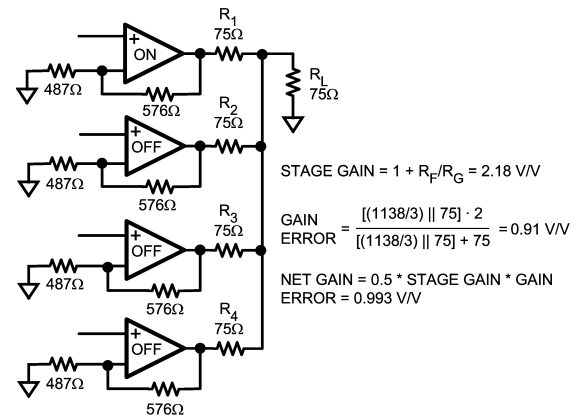

20129917

FIGURE 3. Multiplexer Gain Compensation

BUILDING A 4:1 MULTIPLEXER

Figure 4 shows an 4:1 MUX using two LMH6570's.

Application Notes (Continued)

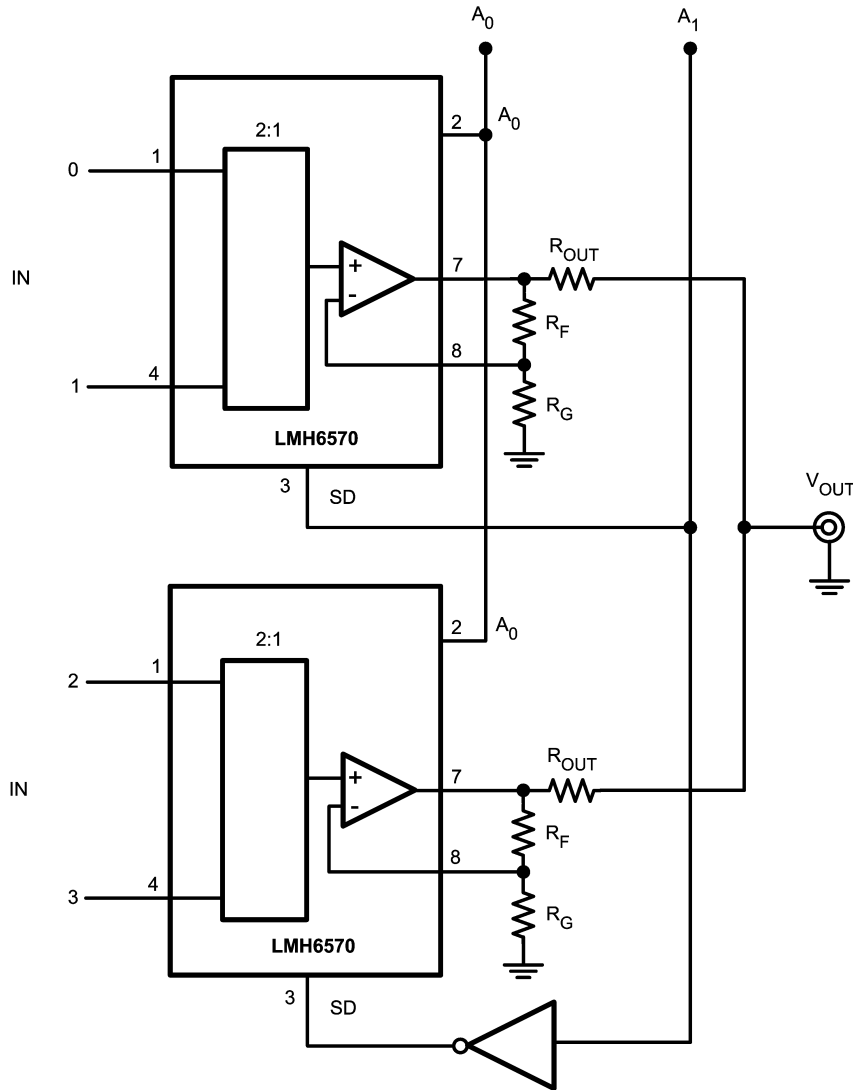

20129918

FIGURE 4. 4:1 MUX USING TWO LMH6570's

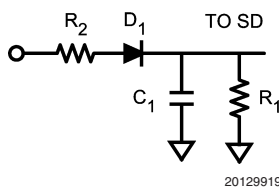

20129919

FIGURE 5. Delay Circuit Implementation

If it is important in the end application to make sure that no two inputs are presented to the output at the same time, an optional delay block can be added, to drive the SHUTDOWN pin of each device, as shown. *Figure 5* shows one possible approach to this delay circuit. The delay circuit shown will delay SHUTDOWN's H to L transitions (R_1 and C_1 decay)

but won't delay its L to H transition. R_2 should be kept small compared to R_1 in order to not reduce the SHUTDOWN voltage and to produce little or no delay to SHUTDOWN.

Other Applications

The LMH6570 could support a dual antenna receiver with two physically separate antennas. Monitoring the signal strength of the active antenna and switching to the other antenna when a fade is detected is a simple way to achieve spacial diversity. This method gives about a 3dB boost in average signal strength and is the least expensive method for combining signals.

DRIVING CAPACITIVE LOADS

Capacitive output loading applications will benefit from the use of a series output resistor R_{OUT} . *Figure 6* shows the use of a series output resistor, R_{OUT} , to stabilize the amplifier output under capacitive loading. Capacitive loads of

Other Applications (Continued)

5 to 120 pF are the most critical, causing ringing, frequency response peaking and possible oscillation. The chart "Suggested R_{OUT} vs. Cap Load" gives a recommended value for selecting a series output resistor for mitigating capacitive loads. The values suggested in the charts are selected for 0.5 dB or less of peaking in the frequency response. This gives a good compromise between settling time and bandwidth. For applications where maximum frequency response is needed and some peaking is tolerable, the value of R_{OUT} can be reduced slightly from the recommended values.

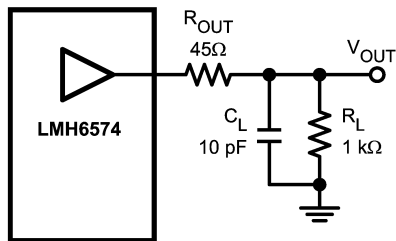

20129924

FIGURE 6. Decoupling Capacitive Loads

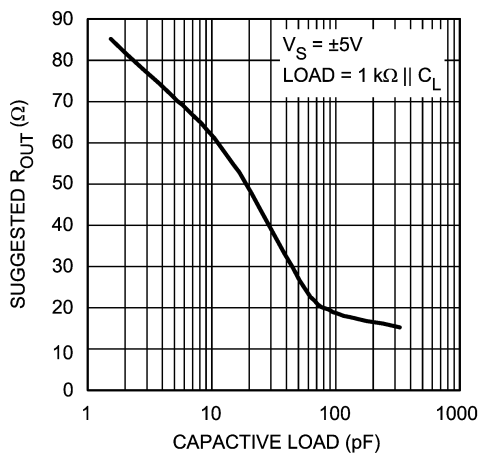

20129915

FIGURE 7. Suggested R_{OUT} vs. Capacitive Load

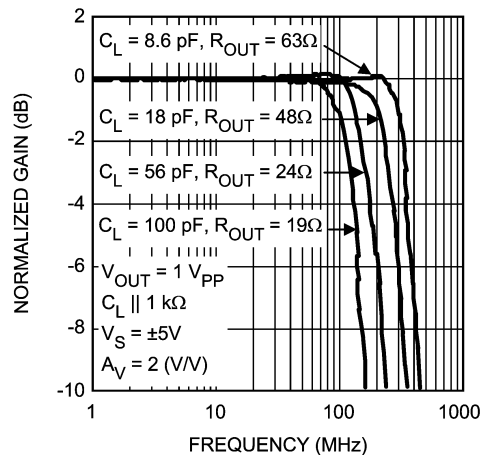

20129914

FIGURE 8. Frequency Response vs. Capacitive Load

LAYOUT CONSIDERATIONS

Whenever questions about layout arise, use the evaluation board as a guide. The LMH730277 is the evaluation board supplied with samples of the LMH6570. To reduce parasitic capacitances, ground and power planes should be removed near the input and output pins. For long signal paths controlled impedance lines should be used, along with impedance matching elements at both ends. Bypass capacitors should be placed as close to the device as possible. Bypass capacitors from each rail to ground are applied in pairs. The larger electrolytic bypass capacitors can be located farther from the device, the smaller ceramic capacitors should be placed as close to the device as possible. In Figure 1, the capacitor between V^+ and V^- is optional, but is recommended for best second harmonic distortion. Another way to enhance performance is to use pairs of 0.01 μ F and 0.1 μ F ceramic capacitors for each supply bypass.

POWER DISSIPATION

The LMH6570 is optimized for maximum speed and performance in the small form factor of the standard SOIC package. To ensure maximum output drive and highest performance, thermal shutdown is not provided. Therefore, it is of utmost importance to make sure that the T_{JMAX} is never exceeded due to the overall power dissipation.

Follow these steps to determine the maximum power dissipation for the LMH6570:

1. Calculate the quiescent (no-load) power: $P_{AMP} = I_{CC} \cdot (V_S)$, where $V_S = V^+ - V^-$.
2. Calculate the RMS power dissipated in the output stage: $P_D (rms) = rms((V_S - V_{OUT}) \cdot I_{OUT})$, where V_{OUT} and I_{OUT} are the voltage across and the current through the external load and V_S is the total supply voltage.
3. Calculate the total RMS power: $P_T = P_{AMP} + P_D$.

The maximum power that the LMH6570 package can dissipate at a given temperature can be derived with the following equation:

$P_{MAX} = (150^\circ - T_{AMB}) / \theta_{JA}$, where T_{AMB} = Ambient temperature ($^\circ$ C) and θ_{JA} = Thermal resistance, from junction package to ambient, for a given package ($^\circ$ C/W). For the SOIC package θ_{JA} is 150 $^\circ$ C/W.

Other Applications (Continued)

ESD PROTECTION

The LMH6570 is protected against electrostatic discharge (ESD) on all pins. The LMH6570 will survive 2000V Human Body model and 200V Machine model events. Under normal operation the ESD diodes have no effect on circuit performance. There are occasions, however, when the ESD di-

odes will be evident. If the LMH6570 is driven by a large signal while the device is powered down the ESD diodes will conduct. The current that flows through the ESD diodes will either exit the chip through the supply pins or will flow through the device, hence it is possible to power up a chip with a large signal applied to the input pins. Using the shutdown mode is one way to conserve power and still prevent unexpected operation.

Physical Dimensions inches (millimeters) unless otherwise noted

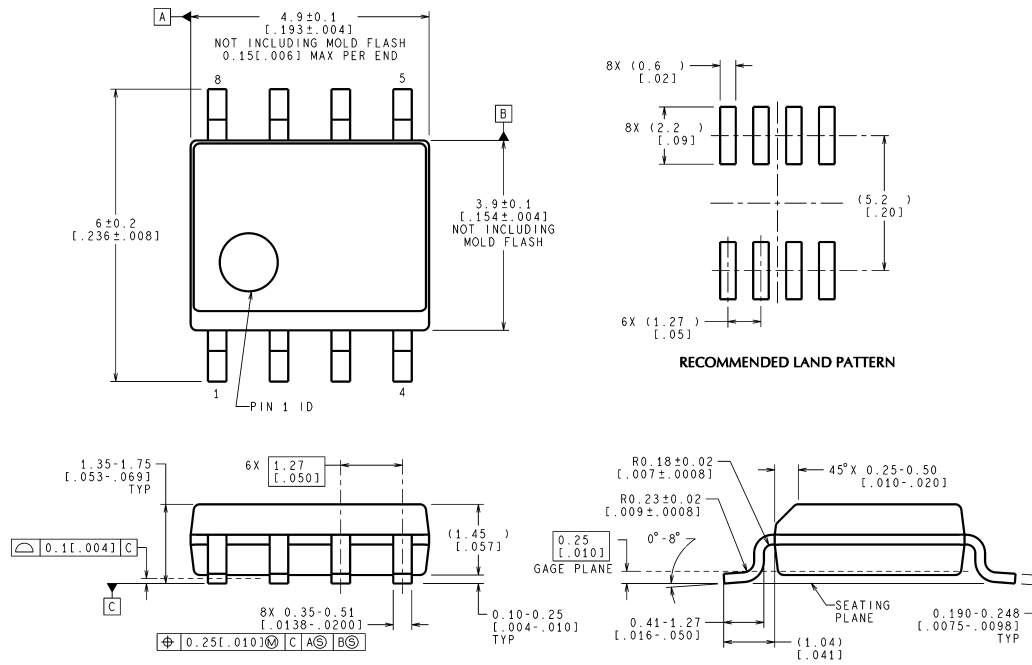

CONTROLLING DIMENSION IS MILLIMETER
VALUES IN [] ARE INCHES
DIMENSIONS IN () FOR REFERENCE ONLY

M08A (Rev K)

**8-Pin SOIC
NS Package Number M08A**

National does not assume any responsibility for use of any circuitry described, no circuit patent licenses are implied and National reserves the right at any time without notice to change said circuitry and specifications.

For the most current product information visit us at www.national.com.

LIFE SUPPORT POLICY

NATIONAL'S PRODUCTS ARE NOT AUTHORIZED FOR USE AS CRITICAL COMPONENTS IN LIFE SUPPORT DEVICES OR SYSTEMS WITHOUT THE EXPRESS WRITTEN APPROVAL OF THE PRESIDENT AND GENERAL COUNSEL OF NATIONAL SEMICONDUCTOR CORPORATION. As used herein:

1. Life support devices or systems are devices or systems which, (a) are intended for surgical implant into the body, or (b) support or sustain life, and whose failure to perform when properly used in accordance with instructions for use provided in the labeling, can be reasonably expected to result in a significant injury to the user.
2. A critical component is any component of a life support device or system whose failure to perform can be reasonably expected to cause the failure of the life support device or system, or to affect its safety or effectiveness.

BANNED SUBSTANCE COMPLIANCE

National Semiconductor manufactures products and uses packing materials that meet the provisions of the Customer Products Stewardship Specification (CSP-9-111C2) and the Banned Substances and Materials of Interest Specification (CSP-9-111S2) and contain no "Banned Substances" as defined in CSP-9-111S2.

 **National Semiconductor**
Americas Customer
Support Center
Email: new.feedback@nsc.com
Tel: 1-800-272-9959

National Semiconductor
Europe Customer Support Center
Fax: +49 (0) 180-530 85 86
Email: europe.support@nsc.com
Deutsch Tel: +49 (0) 69 9508 6208
English Tel: +44 (0) 870 24 0 2171
Français Tel: +33 (0) 1 41 91 8790

National Semiconductor
Asia Pacific Customer
Support Center
Email: ap.support@nsc.com

National Semiconductor
Japan Customer Support Center
Fax: 81-3-5639-7507
Email: jpn.feedback@nsc.com
Tel: 81-3-5639-7560

www.national.com