



深圳市拓普微科技开发有限公司
SHENZHEN TOPWAY TECHNOLOGY CO., LTD.

LMK070DICFWD-AMA

LCD Module User Manual

Prepared by: HeHongLiang Date: 2017-10-25	Checked by: Date:	Approved by: Date:
--	----------------------------------	-----------------------------------

Rev.	Descriptions	Release Date
0.1	Preliminary release	2016-04-14
0.2	Typing correction	2016-04-22
0.3	Update 2.0&8.0	2016-08-25
0.4	Assemble Precaution	2017-10-25

Table of Content

1. General Specification	3
2. Block Diagram	3
3. Terminal Function	4
3.1 Input/output Terminal (K1).....	4
4. Absolute Maximum Ratings	5
5. Electrical Characteristics	5
5.1 DC Characteristics.....	5
5.2 Touch panel Characteristics	5
5.3 POWER ON/OFF SEQUENCE	6
6. AC Characteristics	6
6.1 Timing Characteristics	6
6.2 Input Clock and Data Timing Diagram.....	7
6.3 Timing.....	7
6.4 Data Input Format.....	8
7. Optical Characteristics	9
8. Precautions for Use of LCD Modules	10
8.1 Handling Precautions	10
8.2 Storage precautions	10
8.3 Transportation Precautions	10
10 . Assemble Precaution	11

Applications

This Module is designed for application which require high quality flat panel displays. It is also a good substitute for many outmoded CSTN module in the industrial application.

1. General Specification

Signal Interface :	Digital 16-bits RGB
Display Technology :	a-Si TFT active matrix
Display Mode :	Transmissive / Normal White
Screen Size(Diagonal) :	7.0"
Outline Dimension :	207.6 x 132.6 x 30 MAX(mm) (with mounting Bezel) (see attached drawing for details)
Active Area :	154.08 x 85.92 (mm)
Number of dots :	800 x 3 (RGB) x 480
Pixel Pitch :	0.1926 x 0.179 (mm)
Pixel Configuration :	RGB Stripe
Backlight :	White LED
Viewing Direction :	6H (gray scale inverse) (*1) 12H (*2)
Touch Panel:	Toughened 4wire resistive
Operating Temperature :	-20 ~ +70°C
Storage Temperature :	-30 ~ +80°C

Note:

*1. For saturated color display content (eg. pure-red, pure-green, pure-blue or pure-colors-combinations).

*2. For "color scales" display content.

*3. Color tone may slightly change by temperature and driving condition.

2. Block Diagram

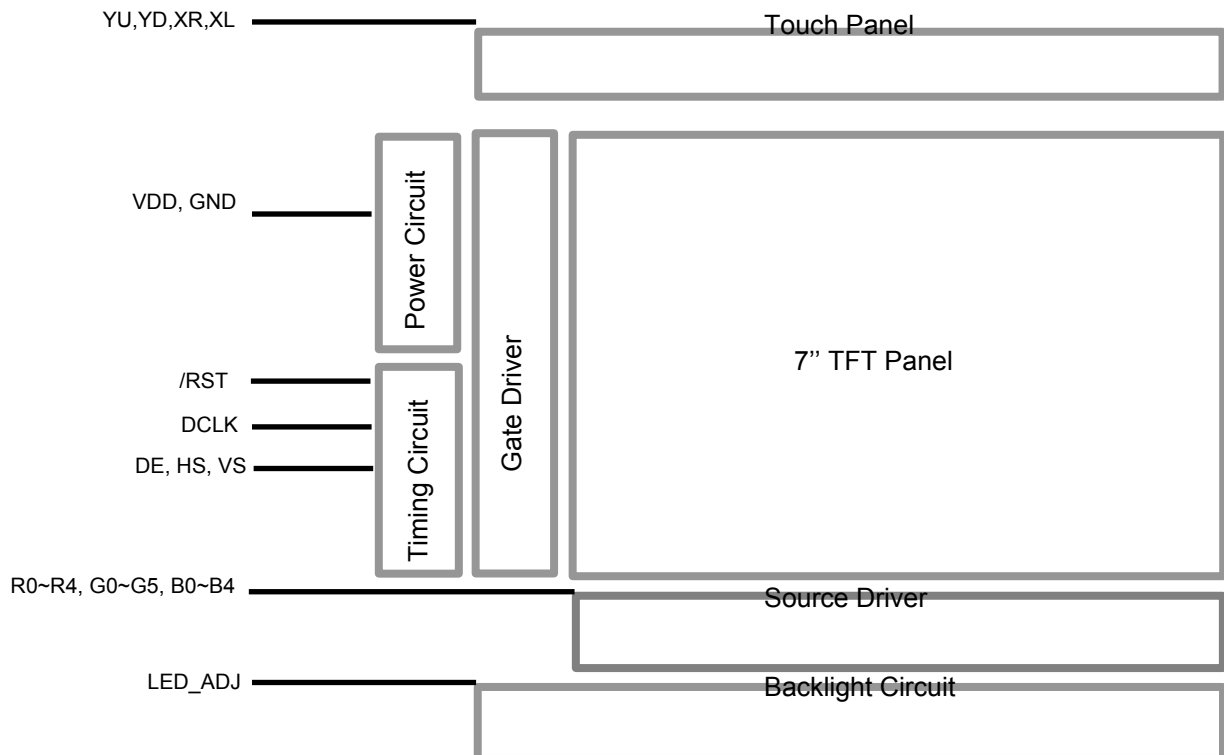

3. Terminal Function

3.1 Input/output Terminal (K1)

K2 Pin No.	Pin Name	I/O	Descriptions
1	VDD	Power	Positive Power Supply
2	B0	Input	Blue Data
3	B1		
4	B2		
5	VDD	Power	Positive Power Supply
6	B3	Input	Blue Data
7	B4		
8	G0	Input	Green Data
9	GND	Power	Power Supply Ground
10	G1	Input	Green Data
11	G2		
12	G3		
13	GND	Power	Power Supply Ground
14	G4	Input	Green Data
15	G5		
16	R0	Input	Red Data
17	GND	Power	Power Supply Ground
18	R1	Input	Red Data
19	R2		
20	R3		
21	GND	Power	Power Supply Ground
22	R4	Input	Red Data
23	/RST	Input	Reset Signal Input
24	GND	Power	Power Supply Ground
25	DE	Input	DE Signal Input(Default)
26	VS	Input	Vertical Sync Input
27	HS	Input	Horizontal Sync Input
28	GND	Power	Power Supply Ground
29	DCLK	Input	Data Clock Input Data shall be latched at the falling edge of DCLK.
30	GND	Power	Power Supply Ground
31	LED_ADJ	Input	LED driver adjust control
32	GND	Power	Power Supply Ground
33	YU	Passive	Touch Panel Up side sensing
34	YD	Passive	Touch Panel Down side sensing
35	XR	Passive	Touch Panel Right side sensing
36	XL	Passive	Touch Panel Left side sensing

4. Absolute Maximum Ratings

Items	Symbol	Min.	Max.	Unit	Condition
Power Supply voltage	V _{CC}	-0.3	6.0	V	
Operating Temperature	T _{OP}	-20	70	°C	No Condensation
Storage Temperature	T _{ST}	-30	80	°C	No Condensation

Note:

- *1. This rating applies to all parts of the module. And it should be not exceeded.
- *2. The operating temperature only guarantees operation of the circuit. The contrast, response speed, and the other specification related to electro-optical display quality is determined at the room temperature, T_{OP}=25.
- *3. Ambient temperature when the backlight is lit (reference value)
- *4. Any Stresses exceeding the Absolute Maximum Ratings may cause substantial damage to the device. Functional operation of this device at other conditions beyond those listed in the specification is not implied and prolonged exposure to extreme conditions may affect device reliability.

5. Electrical Characteristics

5.1 DC Characteristics

VCC=5.0V, GND=0V ,Top=25°C

Items	Symbol	Min.	Typ.	Max.	Unit	Remark
Power Supply Voltage	V _{CC}	4.7	5.0	5.3	V	(*1)
Input logic high voltage	V _{IH}	3.0	-	3.6	V	
Input logic low voltage	V _{IL}	0	-	0.7	V	
Logic Supply (VDD)	I _{VDD}	-	550	-	mA	LED_ADJ=High (*2)

Note1:

- *1. LED_ADJ=Hi;
- *2. Recommended LED_ADJ PWM Freq. is 3kHz.

*3. Terminal circuit.

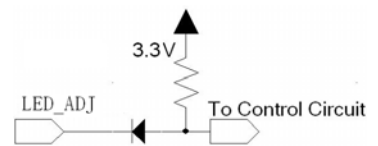

5.2 Touch panel Characteristics

Items	MIN.	TYP.	MAX.	Unit	Applicable Pin
Terminal resistance	100	-	900	Ω	X- terminal
	200	-	1200	Ω	Y- terminal
Operating Voltage	-	-	7	V	-
Response time	-	-	10	ms	-
Life Time	-	1,000,000	-	times	-

Note1:

Exceeding the recommended Condition could cause substantial damage to the touch panel and shorten its lifetime.

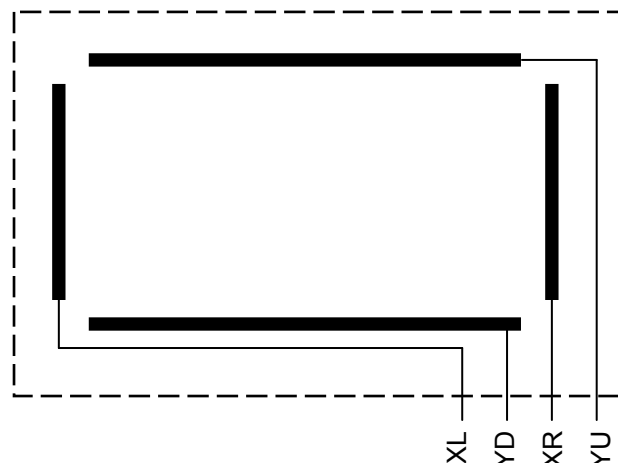

5.3 POWER ON/OFF SEQUENCE

Parameter	Symbol	MIN.	TYP.	MAX.	Unit	Note
VDD 5.0V to signal starting	Tp1	0	-	50	ms	
Signal starting to backlight on	Tp2	150	-	-	ms	
Signal off to VDD 5.0V	Tp3	0	-	50	ms	
Backlight off to signal off	Tp4	150	-	-	ms	

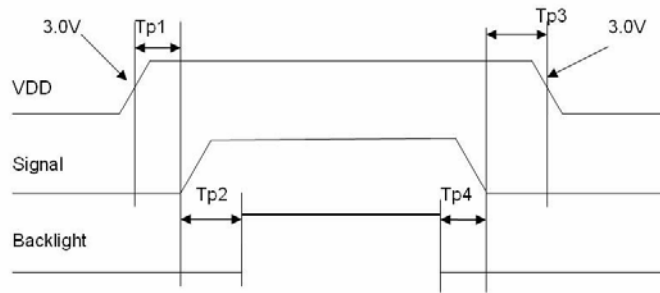

Interface Power On/Off Sequence

6. AC Characteristics

6.1 Timing Characteristics

Item	Symbol	MIN.	TYP.	MAX.	Unit	Remark
HS setup time	Thst	8	-	-	ns	
HS hold time	Thhd	8	-	-	ns	
VS setup time	Tvst	8	-	-	ns	
VS hold time	Tvhd	8	-	-	ns	
Data setup time	Tdsu	8	-	-	ns	
Data hole time	Tdhd	8	-	-	ns	
DE setup time	Tesu	8	-	-	ns	
V _{CC} Power On Slew rate	TPOR	-	-	20	ms	From 0 to 90% V _{CC}
DCLK cycle time	Tcph	20	-	-	ns	
DCLK pulse duty	Tcwh	40	50	60	%	

6.2 Input Clock and Data Timing Diagram

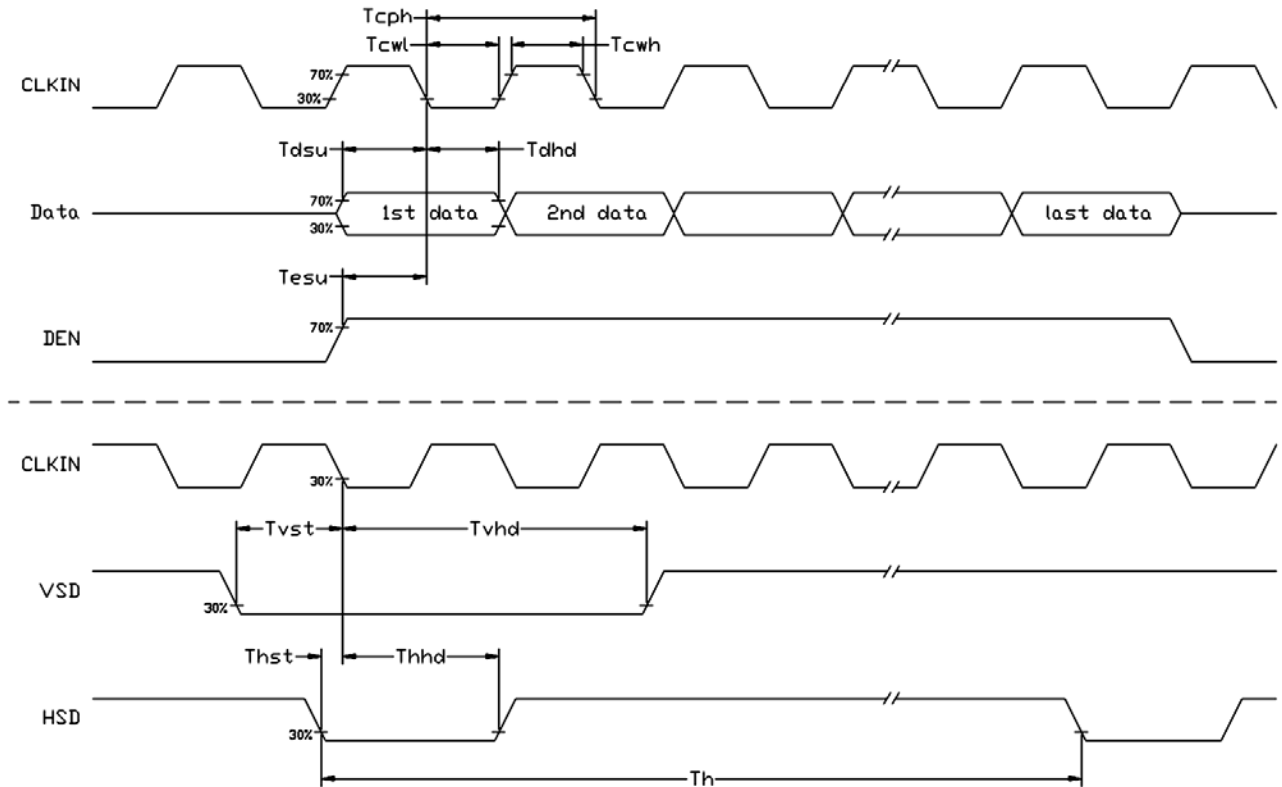

6.3 Timing

Item	Symbol	MIN.	TYP.	MAX.	Unit	Remark
Horizontal Display Area	thd	-	800	-	DCLK	
DCLK Frequency	fclk	26.4	33.3	46.8	MHz	
One Horizontal Line	th	862	1056	1200	DCLK	
HS pulse width	thpw	1	-	40	DCLK	
HS Blanking	thb	46	46	46	DCLK	
HS Front Porch	thfp	16	210	354	DCLK	
Vertical Display Area	tvd	-	480	-	TH	
VS period time	tv	510	525	650	TH	
VS pulse width	tpw	1	-	20	TH	
VS Blanking	tvb	23	23	23	TH	
VS Front Porch	tvfp	7	22	147	TH	

6.4 Data Input Format

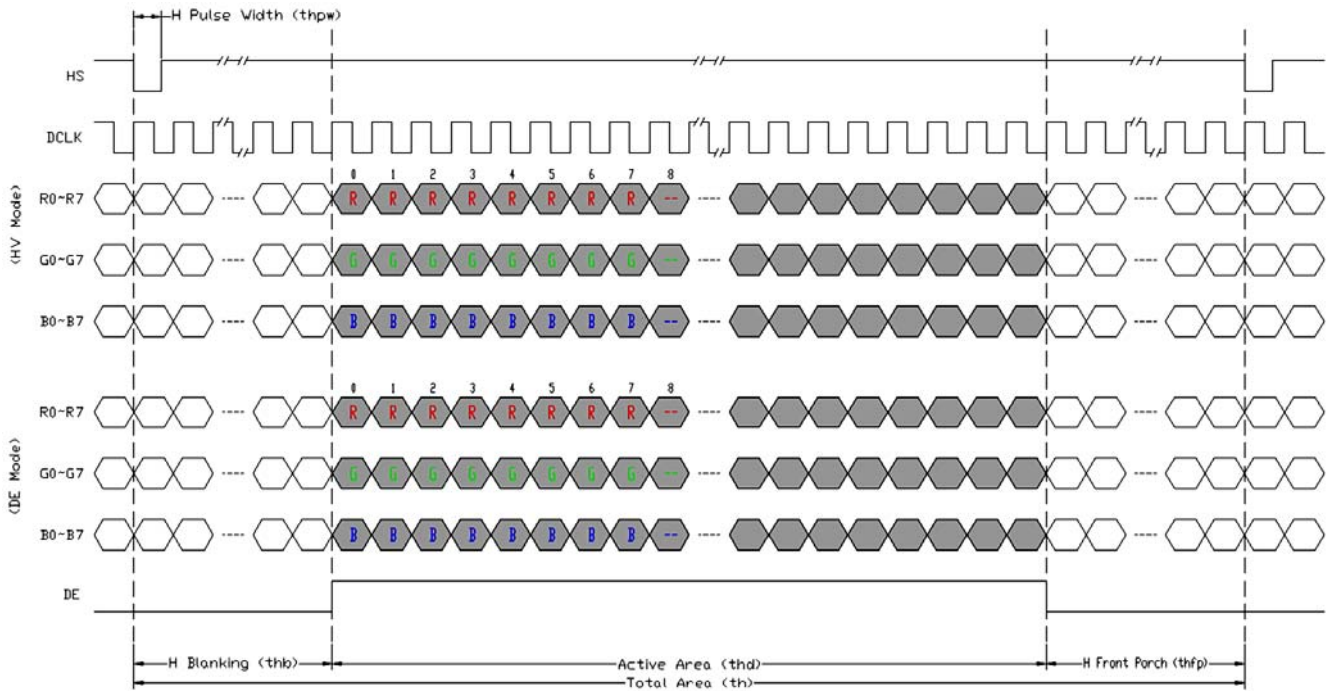

Horizontal input timing diagram.

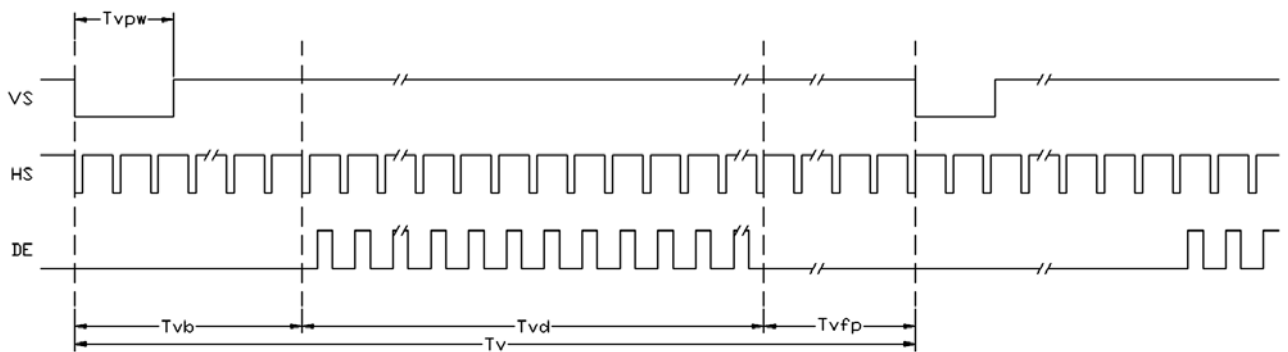

Vertical input timing diagram.

7. Optical Characteristics

Item	Symbol	Condition	MIN.	TYP.	MAX.	UNIT	Note.
Viewing angle (CR ≥ 10)	θ_L	9 o'clock	60	70	-	degree	*2
	θ_R	3 o'clock	60	70	-		
	θ_T	12 o'clock	40	50	-		
	θ_B	6 o'clock	60	70	-		
Response Time	T_f	Normal $\theta=0^\circ$	-	10	20	msec	*3
	T_r		-	15	30	msec	
Contrast ratio	CR		400	500	-	-	*1
Color chromaticlty	W_X		0.26	0.31	0.26	-	
	W_Y		0.28	0.33	0.38	-	
Luminance	L		-	900	-	cd/m ²	*5
Luminance uniformity	Y_U		70	75	-	%	*4

Note:

***1. Definition of Contrast Ratio**

The contrast ratio could be calculate by the following expression:

Contrast Ratio (CR) = Luminanc with all pixels white / Luminance with all pixels black

***2 Definition of Viewing Angle**

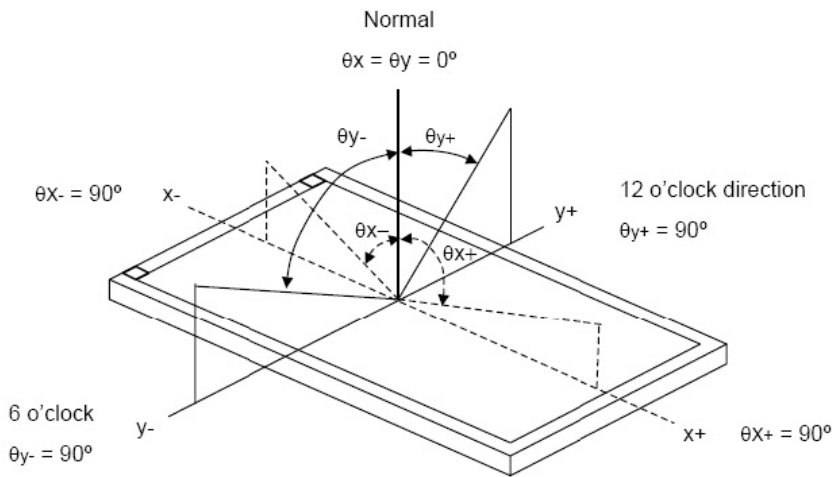

***3 Definition of response time**

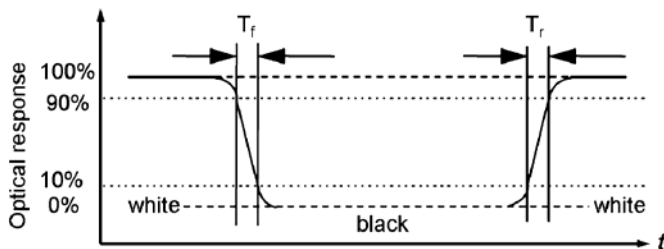

*5 Exclude TP & Cover Film

***4 Definition of Luminance Uniformity**

Luminance uniformity (Lu) =
Min. Luminance form pt1~pt9 / Max Luminance form Pt1~pt9

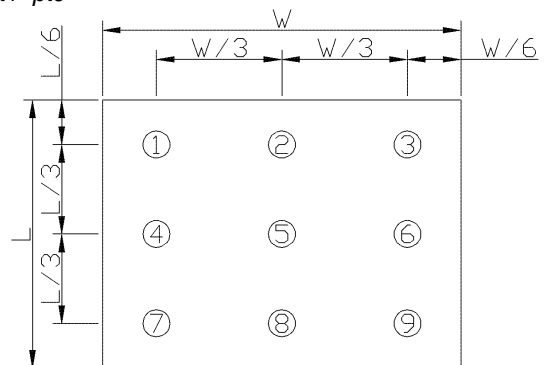

8. Precautions for Use of LCD Modules

8.1 Handling Precautions

- 9.1.1 The display panel is made of glass. Do not subject it to a mechanical shock by dropping it from a high place, etc.
- 9.1.2 If the display panel is damaged and the liquid crystal substance inside it leaks out, be sure not to get any in your mouth, if the substance comes into contact with your skin or clothes, promptly wash it off using soap and water.
- 9.1.3 Do not apply excessive force to the display surface or the adjoining areas since this may cause the color tone to vary.
- 9.1.4 The polarizer covering the display surface of the LCD module is soft and easily scratched. Handle this polarizer carefully.
- 9.1.5 If the display surface is contaminated, breathe on the surface and gently wipe it with a soft dry cloth. If still not completely clear, moisten cloth with one of the following solvents:
 - Isopropyl alcohol
 - Ethyl alcoholSolvents other than those mentioned above may damage the polarizer. Especially, do not use the following:
 - Water
 - Ketone
 - Aromatic solvents
- 9.1.6 Do not attempt to disassemble the LCD Module.
- 9.1.7 If the logic circuit power is off, do not apply the input signals.
- 9.1.8 To prevent destruction of the elements by static electricity, be careful to maintain an optimum work environment.
 - 9.1.8.1 Be sure to ground the body when handling the LCD Modules.
 - 9.1.8.2 Tools required for assembly, such as soldering irons, must be properly ground.
 - 9.1.8.3 To reduce the amount of static electricity generated, do not conduct assembly and other work under dry conditions.
 - 9.1.8.4 The LCD Module is coated with a film to protect the display surface. Be care when peeling off this protective film since static electricity may be generated.

8.2 Storage precautions

- 9.2.1 When storing the LCD modules, avoid exposure to direct sunlight or to the light of fluorescent lamps.
- 9.2.2 The LCD modules should be stored under the storage temperature range. If the LCD modules will be stored for a long time, the recommend condition is:
Temperature : 0°C ~ 40°C Relatively humidity: ≤80%
- 9.2.3 The LCD modules should be stored in the room without acid, alkali and harmful gas.

8.3 Transportation Precautions

The LCD modules should be no falling and violent shocking during transportation, and also should avoid excessive press, water, damp and sunshine.

10 . Assemble Precaution

安装注意事项

1. Customer front panel opening and thickness for TOPWAY display module should be fit for its assembling and sealing.

- The suggested assemble gap(A) should be about 0.3~0.5mm on each side.
- The suggested front panel thickness(B) should be about 1.5~4.0mm.

客户面板开窗及厚度应适合 TOPWAY 显示模块的安装及密封.

- 建议每边安装间隙(A)约为 0.3 ~0.5mm.
- 建议面板厚度(B) 约为 1.5~4.0mm.

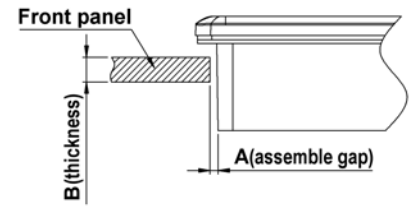

2. A silicon sealing ring ships with TOPWAY display module. It should be in place before assembling to the front panel.

TOPWAY 显示模块上的硅胶密封圈在安装时确保嵌入到位.

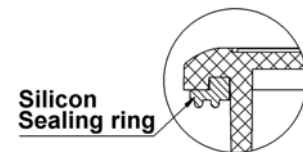

3. It should fix the TOPWAY display module into the front panel with two steps.

- Pre-fixing: Slightly tighten the screws on beam clamp in sequence as picture on the right side.
- Final-fixing: Tighten the fixing screws on beam clamp in sequence as well with twist torque about 6~8kg.cm (*1) . and put the beam clamp straight.

Note:

*1. Over tightening might damage the shell and cause bad sealing result.

应分两步将 TOPWAY 显示模块固定在面板上.

- 预紧: 将卡扣螺钉按右图所示顺序稍加预紧.
- 紧定:再次按顺序用 **6~8kg.cm** 扭力拧紧卡扣螺钉(*1),并注意卡扣置正无歪斜.

注:

*1. 过度拧紧可能会损坏外壳和影响密封效果.

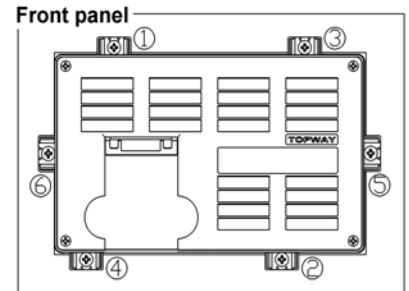

4. It is strongly suggested to check the seal balancing of the four-side of the TOPWAY display module.

- The suggested after assemble sealed gap(C) should be about 1.0~1.5mm.

需注意检查 TOPWAY 显示模块四周在安装后保证平衡密封.

- 建议组装后的密封间隙(C)约为 1.0 ~1.5 mm.

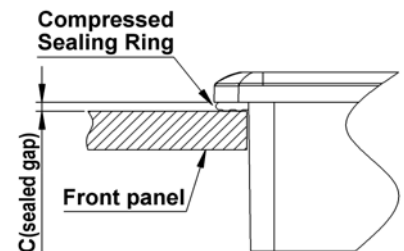

5. Others:

- Never hot plug the device! Power off the device before connect or disconnect the display module.
- Don't forget to remove the cover protective film for normal operation.

其它:

- 视频线禁止带电插拔! 在连接或断开显示模块之前先关闭设备电源.
- 使用前请揭去保护膜.