

Operational Amplifiers

Low Supply Current Ground Sense Operational Amplifiers



LMR341G

● **General Description**

LMR341G is single CMOS Op-Amp with shutdown function, low supply voltage operation and output full swing. There are suitable for battery equipment. MOS-FET input stage provide low input bias current. It is capable to use for sensor applications.

● **Features**

- Low operating supply voltage
- Input Ground Sense, Output Full Swing
- High large signal voltage gain
- Low input bias current
- Low supply current
- Low input offset voltage
- Shutdown function

● **Applications**

- Customer electronics
- Buffer
- Active filter
- Mobile equipment
- Battery equipment

● **Simplified Schematic**

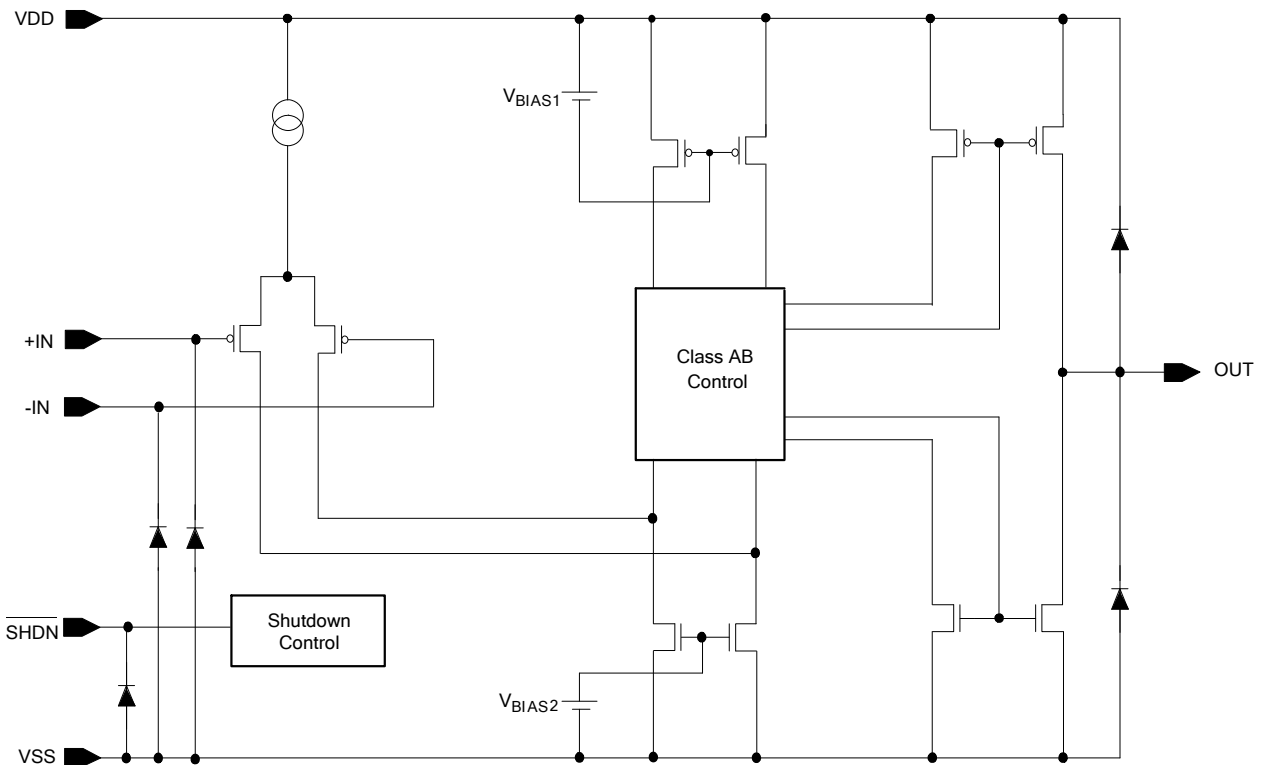

Figure 1. Simplified Schematic

● **Key Specifications**

- Low Operating Supply Voltage (single supply): +2.7V to +5.0V
- High voltage gain (RL=2KΩ): 103dB(Typ.)
- Wide Temperature Range: -40°C to +85°C
- Turn on time from shutdown: 15μs (Typ.)
- Low Input Offset Voltage: 4mV (Max.)
- Low Input Bias Current: 1pA (Typ.)

● **Package**

SSOP6

W(Typ.) xD(Typ.) xH(Max.)
2.90mm x 2.80mm x 1.25mm

○Product structure : Silicon monolithic integrated circuit ○This product is not designed protection against radioactive rays.

●Pin Configuration

LMR341G : SSOP6

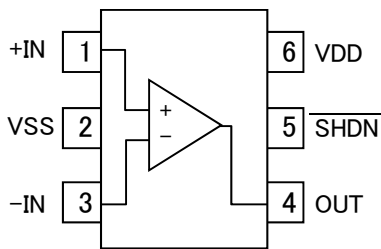

Pin No.	Pin Name
1	+IN
2	VSS
3	-IN
4	OUT
5	SHDN
6	VDD

Package
SSOP6
LMR341G

●Shutdown

Pin	Input condition	State
SHDN	VSS	Shutdown
	VDD	Active

Note: Please refer to Electrical Characteristics regarding the turn on and off voltage.

●Ordering Information

L M R 3 4 1 G	-	T R
Part Number LMR341	Package G:SSOP6	Packaging and forming specification TR: Embossed tape and reel

●Line-up

Topr	Package		Operable Part Number
-40°C to +85°C	SSOP6	Reel of 3000	LMR341G-TR

●Absolute Maximum Ratings(Ta=25°C)

Parameter	Symbol	Ratings	Unit
Supply Voltage	VDD-VSS	+7	V
Power dissipation	Pd	SSOP6 675 ^{*1*2}	mW
Differential Input Voltage ^{*3}	Vid	VDD to VSS	V
Input Common-mode Voltage Range	Vicm	(VSS - 0.3) to (VDD + 0.3)	V
Operable with low voltage	Vopr	+2.7 to +5.0	V
Operating Temperature	Topr	- 40 to +85	°C
Storage Temperature	Tstg	- 55 to +150	°C
Maximum Junction Temperature	Tjmax	+150	°C

Note: Absolute maximum rating item indicates the condition which must not be exceeded.
Application of voltage in excess of absolute maximum rating or use out absolute maximum rated temperature environment may cause deterioration of characteristics.

- *1 To use at temperature above Ta=25°C reduce 5.4mW/°C.
- *2 Mounted on a FR4 glass epoxy PCB (70mm×70mm×1.6mm).
- *3 The voltage difference between inverting input and non-inverting input is the differential input voltage. Then input terminal voltage is set to more than VSS.

●Electrical Characteristics:

OLMR341G (Unless otherwise specified VDD=+2.7V, VSS=0V, SHDN=VDD)

Parameter	Symbol	Temperature Range	Limits			Unit	Condition
			Min.	Typ.	Max.		
Input Offset Voltage ^{*4 *5}	Vio	25°C	-	0.25	4	mV	VDD=2.7V to 5.0V
		Full Range	-	-	4.5		
Input Offset Voltage Drift	$\Delta V_{io}/\Delta T$	25°C	-	1.7	-	$\mu V/^\circ C$	-
Input Offset Current ^{*4}	Iio	25°C	-	1	-	pA	-
Input Bias Current ^{*4}	Ib	25°C	-	1	-	pA	-
Supply Current	IDD	25°C	-	100	170	μA	Av=0dB, VIN=1.35V
		Full range	-	-	230		
Shutdown Current	IDD_SD	25°C	-	0.2	1000	nA	SHDN=0V
Maximum Output Voltage(High)	VOH	25°C	60	26	-	mV	RL=2k Ω to VDD/2
			30	5	-		RL=10k Ω to VDD/2
Maximum Output Voltage(Low)	VOL	25°C	-	24	60	mV	RL=2k Ω to VDD/2
			-	5	30		RL=10k Ω to VDD/2
Large Signal Voltage Gain	Av	25°C	78	113	-	dB	RL=10k Ω to VDD/2
			-	103	-		RL=2k Ω to VDD/2
Input Common-mode Voltage Range	Vicm	25°C	VSS	-	VDD-1	V	-
Common-mode Rejection Ratio	CMRR	25°C	56	80	-	dB	VCM=1.35V
Power Supply Rejection Ratio	PSRR	25°C	65	85	-	dB	VDD=2.7V to 5.0V VCM=0.5V
Output Source Current ^{*6}	Isource	25°C	20	32	-	mA	OUT=0V, short current
Output Sink Current ^{*6}	Isink	25°C	15	24	-	mA	OUT=2.7V, short current
Slew Rate	SR	25°C	-	1.0	-	V/ μs	RL=10k Ω , VIN=1.7V _{P-P}
Gain Bandwidth	GBW	25°C	-	1.0	-	MHz	CL=200pF, RL=100k Ω Av=40dB, f=100kHz
Unit Gain Frequency	fr	25°C	-	1.0	-	MHz	CL=200pF, RL=100k Ω Av=40dB, gain=0dB
Phase Margin	θ	25°C	-	45	-	Deg	CL=20pF, RL=100k Ω Av=40 dB
Gain Margin	GM	25°C	-	4.5	-	dB	CL=20pF, RL=100k Ω Av=40dB
Input Referred Noise Voltage	Vn	25°C	-	40	-	nV/ \sqrt{Hz}	f=1kHz
Total Harmonic Distortion + Noise	THD+N	25°C	-	0.017	-	%	OUT=1V _{P-P} , f=1kHz RL=600 Ω Av=0dB, DIN-AUDIO
Turn On Time From Shutdown	TON	25°C	-	15	-	μs	-
Turn On Voltage High	VSHDN_H	25°C	-	1.8	-	V	-
Turn On Voltage Low	VSHDN_L		-	1.1	-	V	-

*4 Absolute value.

*5 Full range: Ta=-40°C to +85°C

*6 Under the high temperature environment, consider the power dissipation of IC when selecting the output current.
When the terminal short circuits are continuously output, the output current is reduced to climb to the temperature inside IC.

OLMR341G (Unless otherwise specified VDD=+5.0V, VSS=0V, SHDN=VDD)

Parameter	Symbol	Temperature Range	Limits			Unit	Condition
			Min.	Typ.	Max.		
Input Offset Voltage ^{*7 *8}	Vio	25°C	-	0.25	4	mV	VDD=2.7V to 5.0V
		Full Range	-	-	4.5		
Input Offset Voltage Drift	$\Delta V_{io}/\Delta T$	25°C	-	1.9	-	$\mu V/^\circ C$	-
Input Offset Current ^{*7}	Iio	25°C	-	1	-	pA	-
Input Bias Current ^{*7}	Ib	25°C	-	1	-	pA	-
Supply Current	IDD	25°C	-	110	200	μA	Av=0dB, VIN=2.5V
		Full range	-	-	260		
Shutdown Current	IDD_SD	25°C	-	0.5	1000	nA	SHDN=0V
Maximum Output Voltage(High)	VOH	25°C	60	34	-	mV	RL=2k Ω to VDD/2
			30	7	-		RL=10k Ω to VDD/2
Maximum Output Voltage(Low)	VOL	25°C	-	32	60	mV	RL=2k Ω to VDD/2
			-	7	30		RL=10k Ω to VDD/2
Large Signal Voltage Gain	Av	25°C	78	116	-	dB	RL=10k Ω to VDD/2
			-	107	-		RL=2k Ω to VDD/2
Input Common-mode Voltage Range	Vicm	25°C	VSS	-	VDD-1	V	-
Common-mode Rejection Ratio	CMRR	25°C	56	90	-	dB	VCM=2.5V
Power Supply Rejection Ratio	PSRR	25°C	65	85	-	dB	VDD=2.7V to 5.0V VCM=0.5V
Output Source Current ^{*9}	Isource	25°C	85	113	-	mA	OUT=0V, short current
Output Sink Current ^{*9}	Isink	25°C	50	75	-	mA	OUT=5V, short current
Slew Rate	SR	25°C	-	1.0	-	V/ μs	RL=10k Ω , VIN=2V _{P-P}
Gain Bandwidth	GBW	25°C	-	1.0	-	MHz	CL=200pF, RL=10k Ω Av=40dB, f=100kHz
Unit Gain Frequency	fr	25°C	-	1.0	-	MHz	CL=200pF, RL=10k Ω Av=40dB, gain=0dB
Phase Margin	θ	25°C	-	45	-	Deg	CL=20pF, RL=100k Ω Av=40dB
Gain Margin	GM	25°C	-	4.5	-	dB	CL=20pF, RL=100k Ω Av=40dB
Input Referred Noise Voltage	Vn	25°C	-	40	-	nV/ \sqrt{Hz}	Av=40dB, DIN-AUDIO
							f=1kHz
Total Harmonic Distortion + Noise	THD+N	25°C	-	0.012	-	%	OUT=1V _{P-P} , f=1kHz RL=600 Ω Av=0dB, DIN-AUDIO
Turn On Time From Shutdown	TON	25°C	-	15	-	μs	-
Turn On Voltage High	VSHDN_H	25°C	-	3.2	-	V	-
Turn On Voltage Low	VSHDN_L	25°C	-	2.2	-	V	-

*7 Absolute value

*8 Full range: Ta=-40°C to +85°C

*9 Under the high temperature environment, consider the power dissipation of IC when selecting the output current.

When the terminal short circuits are continuously output, the output current is reduced to climb to the temperature inside IC.

Notice

●General Precaution

- 1) Before you use our Products, you are requested to carefully read this document and fully understand its contents. ROHM shall not be in any way responsible or liable for failure, malfunction or accident arising from the use of any ROHM's Products against warning, caution or note contained in this document.
- 2) All information contained in this document is current as of the issuing date and subject to change without any prior notice. Before purchasing or using ROHM's Products, please confirm the latest information with a ROHM sales representative.

●Precaution on using ROHM Products

- 1) Our Products are designed and manufactured for application in ordinary electronic equipments (such as AV equipment, OA equipment, telecommunication equipment, home electronic appliances, amusement equipment, etc.). If you intend to use our Products in devices requiring extremely high reliability (such as medical equipment, transport equipment, traffic equipment, aircraft/spacecraft, nuclear power controllers, fuel controllers, car equipment including car accessories, safety devices, etc.) and whose malfunction or failure may cause loss of human life, bodily injury or serious damage to property ("Specific Applications"), please consult with the ROHM sales representative in advance. Unless otherwise agreed in writing by ROHM in advance, ROHM shall not be in any way responsible or liable for any damages, expenses or losses incurred by you or third parties arising from the use of any ROHM's Products for Specific Applications.
- 2) ROHM designs and manufactures its Products subject to strict quality control system. However, semiconductor products can fail or malfunction at a certain rate. Please be sure to implement, at your own responsibilities, adequate safety measures including but not limited to fail-safe design against the physical injury, damage to any property, which a failure or malfunction of our Products may cause. The following are examples of safety measures:
 - [a] Installation of protection circuits or other protective devices to improve system safety
 - [b] Installation of redundant circuits to reduce the impact of single or multiple circuit failure
- 3) Our Products are designed and manufactured for use under standard conditions and not under any special or extraordinary environments or conditions, as exemplified below. Accordingly, ROHM shall not be in any way responsible or liable for any damages, expenses or losses arising from the use of any ROHM's Products under any special or extraordinary environments or conditions. If you intend to use our Products under any special or extraordinary environments or conditions (as exemplified below), your independent verification and confirmation of product performance, reliability, etc. prior to use, must be necessary:
 - [a] Use of our Products in any types of liquid, including water, oils, chemicals, and organic solvents
 - [b] Use of our Products outdoors or in places where the Products are exposed to direct sunlight or dust
 - [c] Use of our Products in places where the Products are exposed to sea wind or corrosive gases, including Cl₂, H₂S, NH₃, SO₂, and NO₂
 - [d] Use of our Products in places where the Products are exposed to static electricity or electromagnetic waves
 - [e] Use of our Products in proximity to heat-producing components, plastic cords, or other flammable items
 - [f] Sealing or coating our Products with resin or other coating materials
 - [g] Use of our Products without cleaning residue of flux (even if you use no-clean type fluxes, cleaning residue of flux is recommended); or Washing our Products by using water or water-soluble cleaning agents for cleaning residue after soldering
 - [h] Use of the Products in places subject to dew condensation
- 4) The Products are not subject to radiation-proof design.
- 5) Please verify and confirm characteristics of the final or mounted products in using the Products.
- 6) In particular, if a transient load (a large amount of load applied in a short period of time, such as pulse) is applied, confirmation of performance characteristics after on-board mounting is strongly recommended. Avoid applying power exceeding normal rated power; exceeding the power rating under steady-state loading condition may negatively affect product performance and reliability.
- 7) De-rate Power Dissipation (Pd) depending on Ambient temperature (Ta). When used in sealed area, confirm the actual ambient temperature.
- 8) Confirm that operation temperature is within the specified range described in the product specification.
- 9) ROHM shall not be in any way responsible or liable for failure induced under deviant condition from what is defined in this document.

●Precaution for Mounting / Circuit board design

- 1) When a highly active halogenous (chlorine, bromine, etc.) flux is used, the residue of flux may negatively affect product performance and reliability.
- 2) In principle, the reflow soldering method must be used; if flow soldering method is preferred, please consult with the ROHM representative in advance.

For details, please refer to ROHM Mounting specification

●Precautions Regarding Application Examples and External Circuits

- 1) If change is made to the constant of an external circuit, please allow a sufficient margin considering variations of the characteristics of the Products and external components, including transient characteristics, as well as static characteristics.
- 2) You agree that application notes, reference designs, and associated data and information contained in this document are presented only as guidance for Products use. Therefore, in case you use such information, you are solely responsible for it and you must exercise your own independent verification and judgment in the use of such information contained in this document. ROHM shall not be in any way responsible or liable for any damages, expenses or losses incurred by you or third parties arising from the use of such information.

●Precaution for Electrostatic

This Product is electrostatic sensitive product, which may be damaged due to electrostatic discharge. Please take proper caution in your manufacturing process and storage so that voltage exceeding the Products maximum rating will not be applied to Products. Please take special care under dry condition (e.g. Grounding of human body / equipment / solder iron, isolation from charged objects, setting of Ionizer, friction prevention and temperature / humidity control).

●Precaution for Storage / Transportation

- 1) Product performance and soldered connections may deteriorate if the Products are stored in the places where:
 - [a] the Products are exposed to sea winds or corrosive gases, including Cl₂, H₂S, NH₃, SO₂, and NO₂
 - [b] the temperature or humidity exceeds those recommended by ROHM
 - [c] the Products are exposed to direct sunshine or condensation
 - [d] the Products are exposed to high Electrostatic
- 2) Even under ROHM recommended storage condition, solderability of products out of recommended storage time period may be degraded. It is strongly recommended to confirm solderability before using Products of which storage time is exceeding the recommended storage time period.
- 3) Store / transport cartons in the correct direction, which is indicated on a carton with a symbol. Otherwise bent leads may occur due to excessive stress applied when dropping of a carton.
- 4) Use Products within the specified time after opening a humidity barrier bag. Baking is required before using Products of which storage time is exceeding the recommended storage time period.

●Precaution for Product Label

QR code printed on ROHM Products label is for ROHM's internal use only.

●Precaution for Disposition

When disposing Products please dispose them properly using an authorized industry waste company.

●Precaution for Foreign Exchange and Foreign Trade act

Since our Products might fall under controlled goods prescribed by the applicable foreign exchange and foreign trade act, please consult with ROHM representative in case of export.

●Precaution Regarding Intellectual Property Rights

- 1) All information and data including but not limited to application example contained in this document is for reference only. ROHM does not warrant that foregoing information or data will not infringe any intellectual property rights or any other rights of any third party regarding such information or data. ROHM shall not be in any way responsible or liable for infringement of any intellectual property rights or other damages arising from use of such information or data.:
- 2) No license, expressly or implied, is granted hereby under any intellectual property rights or other rights of ROHM or any third parties with respect to the information contained in this document.

●Other Precaution

- 1) The information contained in this document is provided on an "as is" basis and ROHM does not warrant that all information contained in this document is accurate and/or error-free. ROHM shall not be in any way responsible or liable for any damages, expenses or losses incurred by you or third parties resulting from inaccuracy or errors of or concerning such information.
- 2) This document may not be reprinted or reproduced, in whole or in part, without prior written consent of ROHM.
- 3) The Products may not be disassembled, converted, modified, reproduced or otherwise changed without prior written consent of ROHM.
- 4) In no event shall you use in any way whatsoever the Products and the related technical information contained in the Products or this document for any military purposes, including but not limited to, the development of mass-destruction weapons.
- 5) The proper names of companies or products described in this document are trademarks or registered trademarks of ROHM, its affiliated companies or third parties.