



Product Information

ISSUE DATE : MARCH. 06, 2007

MODEL : LMS283GF05_(without TSP General)

Note : This product information is subject to change without any notice.

**Mobile Display Development Team
LCD Business
Samsung Electronics Co . , LTD.**



Doc . No	LMS283GF05	Rev.No	001-070306	Page	1/29
----------	------------	--------	------------	------	------

Revision History

Data	Rev. No.	Page	Summary
Feb. 22. 2007	000		Rev.000 was issued.
Mar. 06. 2007	001	18	Add power sequence timing
		21	Add flow chart

Contents

General Description	-----	(4)
1. Absolute Maximum Ratings	-----	(5)
1.1 Absolute Ratings Of Environment		
1.2 Electrical Absolute Ratings		
2. Optical Characteristics	-----	(7)
3. Electrical Characteristics	-----	(11)
3.1 TFT-LCD Module		
3.2 Back-Light Unit		
4. Block Diagram	-----	(13)
4.1 TFT-LCD Block Diagram		
4.2 Back-light Unit		
5. Input Terminal Pin Assignment	-----	(14)
5.1 TFT-LCD Module		
5.2 Back-Light Unit		
5.3 Input Signal, Basic Display Colors and Gray Scale of Each Colors		
6. Interface Specification	-----	(17)
6.1 Serial Peripheral interface		
6.2 Data format for 16/18-bit RGB interface		
6.3 Input signal timing spec		
6.4 Input Timing Characteristics		
7. Operating Sequence	-----	(21)
7.1 Power On / Off		
8. Outline Dimensions	-----	(22)
8.1 Module Outline Dimensions (Total Assa'y)		
9. Packing	-----	(24)
10. Marking & Others	-----	(25)
11. Reliability Test Result	-----	(26)
11.1 Condition		
11.2 Judgement		
12. General Precaution	-----	(28)
12.1 Handling		
12.2 Storage		
12.3 Operation		
12.4 Others		

General Description*** Description**

LMS283GF05 is a TMR type color active matrix TFT (Thin Film Transistor) liquid crystal display (LCD) that uses amorphous silicon TFT as a switching devices. This model is composed of a TFT-LCD module(TFT-LCD panel, driver ICs and FPC), a Back-light unit. The resolution of a 2.83" contains 240 x 320 pixels and can display up to 262,144 colors.

*** Features**

- TMR(Transmissive with micro reflective) type.
- 4 LED Back-light
- Line Inversion mode.
- Low Power Consumption.

*** Applications**

- Display terminals for PDA application products.
- Smart phone / Game machine / Camcoder.

*** General Information**

Items	Specification	Unit	Note
Display area	43.2(H) x 57.6(V)	mm	-
Driver element	a-Si TFT active matrix	-	-
Display colors	262,144	colors	-
Number of pixels	240(H) x RGB x 320(V)	pixel	-
Pixel arrangement	RGB vertical stripe	-	-
Pixel pitch	0.180(H) x 0.180(V)	mm	-
Display mode	Normally White	-	-
Viewing Direction	12:00	o'clock	(3)

*** Mechanical Information**

Item		Min.	Typ.	Max.	Unit	Note
Module Size	Horizontal(H)	52.75	52.9	53.05	mm	(1)
	Vertical(V)	71.55	71.7	71.85	mm	
	Depth(D)	-	1.9	2.0	mm	(1),(2)
Weight		-	(16)	(18)	g	(1)

Note (1) Back-light unit are included.

(2) FPC & Component height is not included

(3) Dark gray scale Inversion

1. Absolute Maximum Ratings

1.1 Absolute Ratings of Environment

Item	Min.	Max.	Unit	Note
Storage temperature	-30	70	°C	(1)
Operating temperature (Ambient temperature)	-20	60	°C	(2),(3)

Note (1) 90 % RH maximum humidity, 60°C maximum wet-bulb temperature

- (2) When operated at a temperature lower than 0°C, the LCD worked slowly and the screen appeared low-contrast images due to the characteristics of LC(Liquid Crystal).
- (3) If any fixed pattern is displayed on LCD for minutes, image-sticking phenomenon may occur.
- (4) Degradation could occur to pixels' TFT when DC BIOS is input into its gate-signal under POWER OFF WAITING STAND-BY & SLEEP MODE. Therefore, LCD should be turn off then.
- (5) Please operate a LCD module on the basis of the recommended S/W(Register DATA). If you want to change any part of the S/W, you must take Samsung's confirmation.

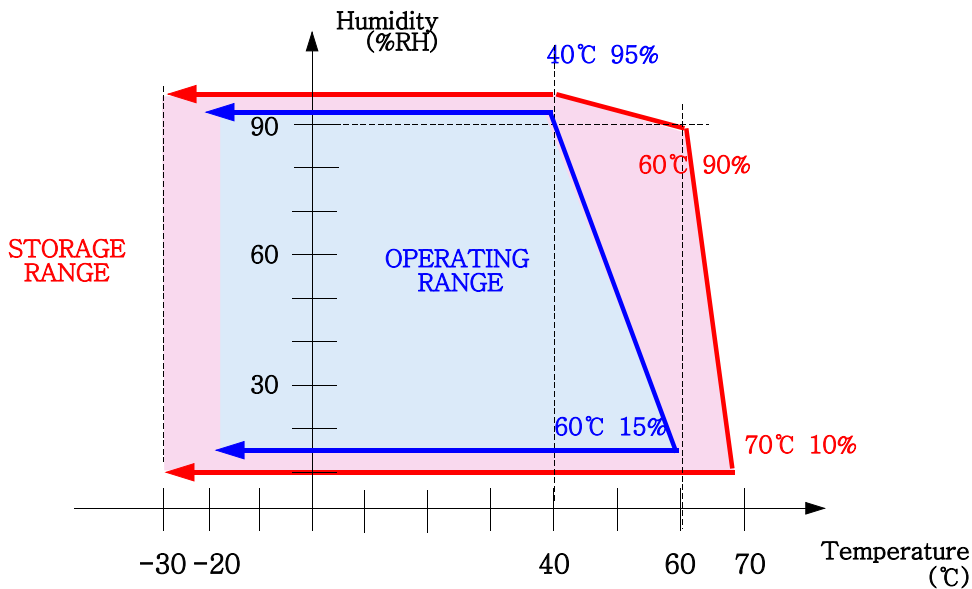

Temperature & Humidity Graph at Absolute Environment

1.2 Electrical Absolute Ratings

(1) TFT-LCD Module

(Ta = Room Temp, V_{ss}=GND=0V)

Characteristics	Symbol	Min.	Max.	Unit	Note
Supply Voltage	V _{DD}	-0.3	5	V	-
Supply Voltage for Step-up	V _{ci}	-0.3	5	V	-

(2) Back-Light Unit

(Ta = Room Temp)

Characteristics	Symbol	Min.	Max.	Unit	Note
Current	I _B	-	25	mA	(1)

Note (1) Permanent damage to the device may occur if maximum values are exceeded or reverse voltage is loaded.

Functional operation should be restricted to the conditions described under normal operating conditions.

2. Optical Characteristics

The following items are measured under stable conditions. The optical characteristics should be measured in a dark room or equivalent state with the methods shown in Note (1),(2),(3)

Measuring equipment: SR-3, BM-7, EZ-Contrast

* Optical Characteristics can be changed without special notice

(Ta = Room Temp, V_{ci} = 2.8V I_B = 20mA)

Item	Symbol	Condition	Min.	Typ.	Max.	Unit	Note	
Contrast ratio (Center point)	C/R1	Normal Viewing Angle B/L On	(290)	(360)	-	-	(4) SR-3	
Luminance of white (Center point)	YL		(260)	(320)	-	cd/m ²	(5) SR-3	
White uniformity	Uw		Φ=0 Θ=0	70	-	-	%	(5) SR-3
Response time	Rising:Tr Falling:Tf		Tr+Tf	-	35	50	msec	(6) BM-7
Color chromaticity (CIE 1931)	White	Wx1	-0.05	(0.31)	+0.05	-	(7) SR-3	
		Wy1		(0.33)				
	Red	Wx1		(0.61)				
		Wy1		(0.36)				
	Green	Wx1		(0.33)				
		Wy1		(0.60)				
	Blue	Wx1		(0.15)				
		Wy1		(0.10)				
Viewing angle	Hor.	θL1	(35)	(50)	-	Degrees	(8) Ez-Contrast	
		θR1	(35)	(50)	-			
	Ver.	φH1	(35)	(50)	-			
		φL1	(15)	(20)	-			

Note (1) The optical characteristics is measured with Back-light.

(2) If product is exposed to high temperatures for extended time, there is a possibility of the polarizer film damage which could degrade the optical characteristics.

Preliminary Specification

Note (3) Test Equipment Setup for the Transmissive Mode (Back-light On)

After stabilizing and leaving the panel alone at a given temperature for 30 min , the measurement should be executed. Measurement should be executed in a stable, windless, and dark room. 30 min after lighting the back-light. This should be measured in the center of screen.

- Back-light Current : 20mA
- Back-Light On condition

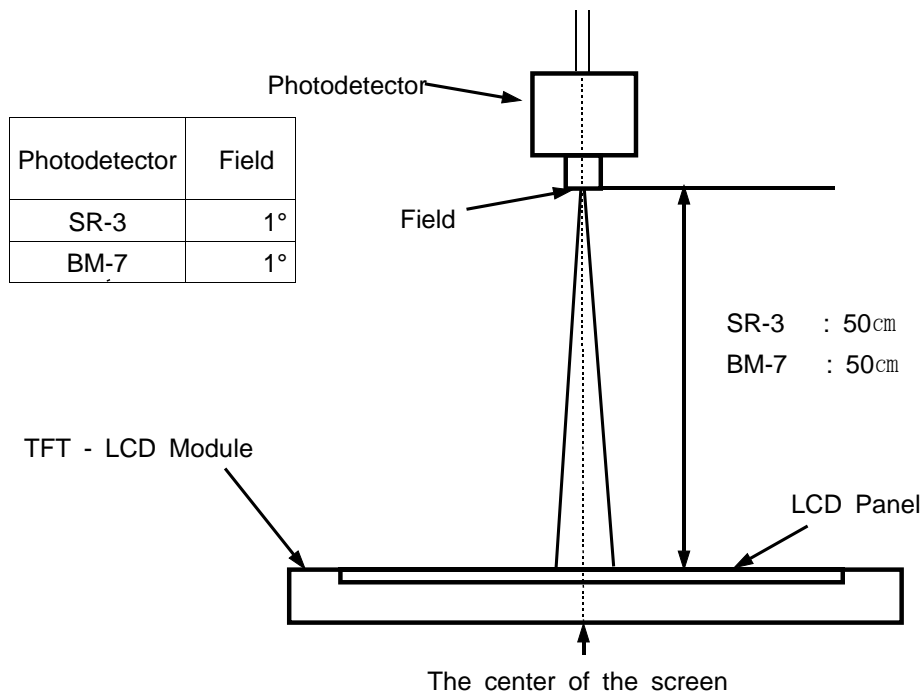

Preliminary Specification

Note (4) Definition of Contrast Ratio (C/R) : Ratio of gray max (Gmax) & gray min (Gmin) at the center point of the panel. If Back-light is on state, it is the light source and the SR-3 will be used to measure.

$$C/R = \frac{G_{\max}}{G_{\min}}$$

* Gmax : Luminance with all pixels white
* Gmin : Luminance with all pixels black

Note (5) Definition of Luminance of White : Luminance of white at center point.

In this case, the incident light is not from the light source but from the Back-light that generates the reflected light source on LCD in the dark room.

$$\text{White Uniformity} = \frac{\text{Min luminance of white among 5-points}}{\text{Max luminance of white among 5-points}} \times 100\%$$

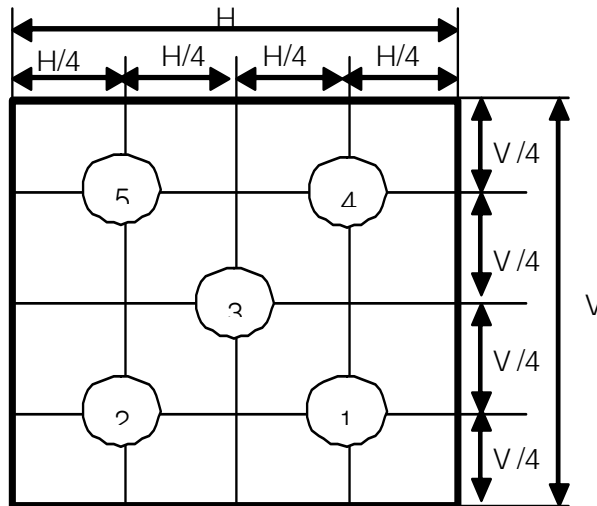

※ Light Source(Chip type white LED : 4EA)

Preliminary Specification

Note (6) Definition of Response time : Sum of T_r , T_f

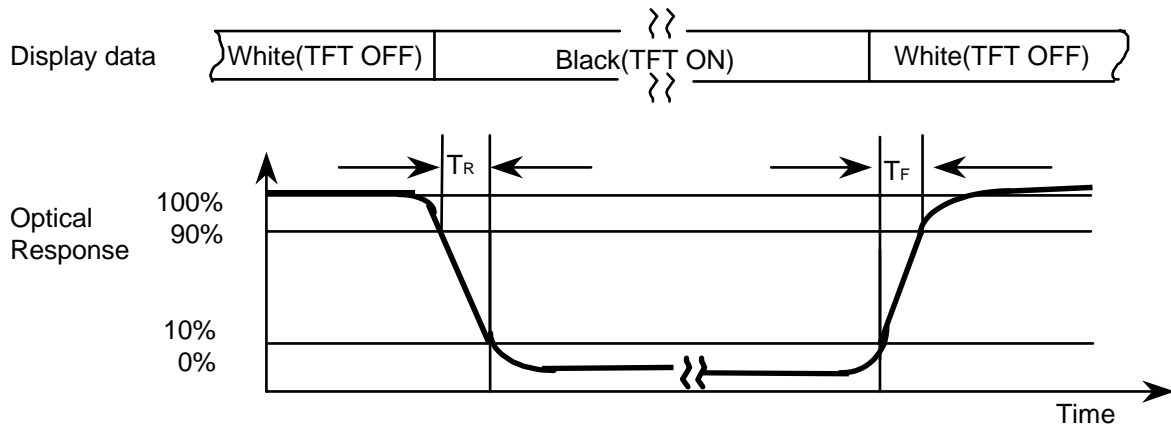

Note (7) Definition of Color Chromaticity (CIE 1931)

Color coordinate of white & red, green, blue at center point.

Note (8) Definition of Viewing Angle : Viewing angle range ($CR \geq 10$)

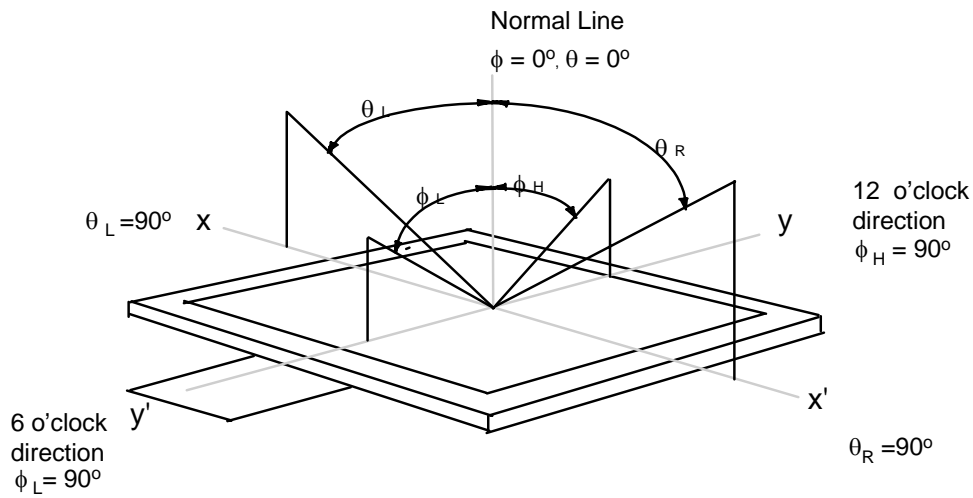

3. Electrical Characteristics

3.1 TFT-LCD Module

(Input Voltage = 2.8V, Ta = Room Temp)

Characteristics		Symbol	MIN.	TYP.	MAX.	Unit	Note
Logic IO supply voltage		IOVCC	1.65	2.8	3.3	V	(1),(2),(6)
DC/DC supply voltage		VCC	2.5	2.8	3.3	V	(1),(2)
Input High Voltage		V _{IH}	0.7xIOVCC	-	IOVCC	V	
Input Low Voltage		V _{IL}	0	-	0.3xIOVCC	V	
Dissipation Current	Full	I _F	-	(10.5)	(14.0)	mA	(1),(2),(4)
Power Dissipation	White	PW	-	(15)	(20)	mW	(1),(2),(5)
	Blue	PB _{lue}	-	(23)	(29)	mW	
	Black	PB	-	(30)	(42)	mW	
	Vertical Stripe	PV	-	(22)	(26)	mW	

* To prevent a latch-up or DC operation of the LCD module, the power on/off sequence should be as the Chapter 7 power on/off Sequence

Note (1) Condition : TFT-LCD module only with typ. electrical characteristics
(Frame Frequency : 80Hz)

(2) V_P = IOVCC = VCC

(3) V_P = 2.8V, The standby mode, where display operation completely stops, halting all the internal operations.

(4) V_P = 2.8V, Power supply current value of motion picture is high speed write mode.

(5) Power dissipation check pattern

[White patten]

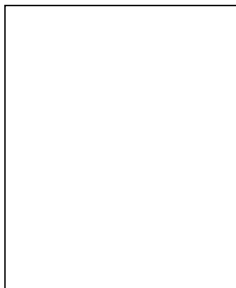

[Black patten]

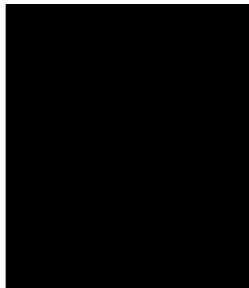

[Blue pattern]

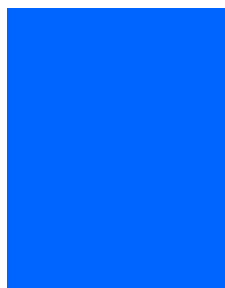

[Vertical Stripe patten]

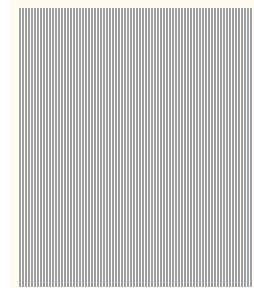

(6) If you change IOVCC(1.65V~3.3V) Typ. value, we must change our FPC circuit design and retest SEC Reliability Test.

(7) Power On Sequence

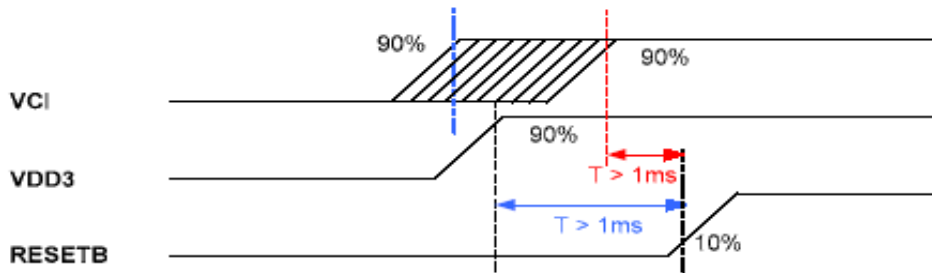
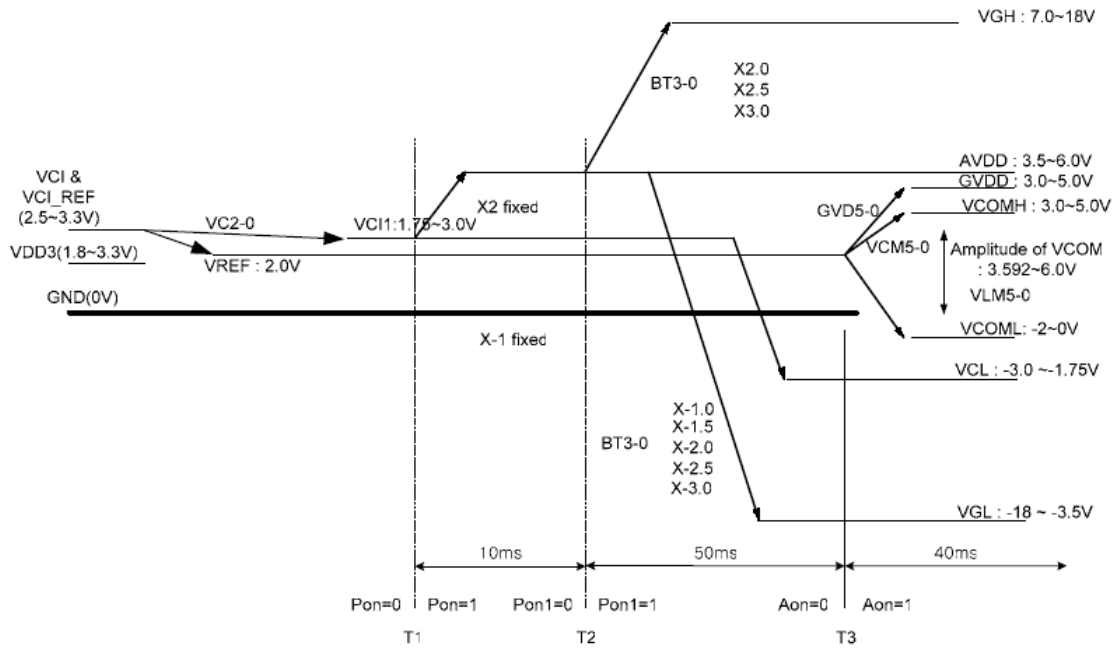

Note : During Power On sequence, VCI may be slower or faster than VDD3
 When VCI goes slower than VDD3(Red case), VCI should reach 90% 10usec before RESETB goes high 10%.
 When VCI goes faster than VDD3(Blue case), VDD3 should reach 90% 10usec before RESETB goes high 10%.

3.2 Back-Light Unit

The Back-light system is an edge-lighting type with 4 white LED(Light Emitting Diode)s. The characteristics of 4 white LEDs are shown in the following tables.

(Ta = Room Temp)

Characteristics	Symbol	Min.	Typ.	Max.	Unit	Note
Current	I_B	-	20	25	mA	(1)
Power Consumption	P_{BL}	-	264	340	mW	(2),(3)

Note (1) 4 white LEDs serial type.

(2) In Typical case, $I_B = 20\text{mA}$, $V_B = 13.2\text{ V}$, $P_{BL} = V_B \times I_B$

(3) In Maximum case, $I_B = 25\text{mA}$, $V_B = 13.6\text{ V}$, $P_{BL} = V_B \times I_B$

4. Block Diagram

4.1 TFT-LCD Block Diagram

12:00 Viewing Direction
(Dark gray Inversion)

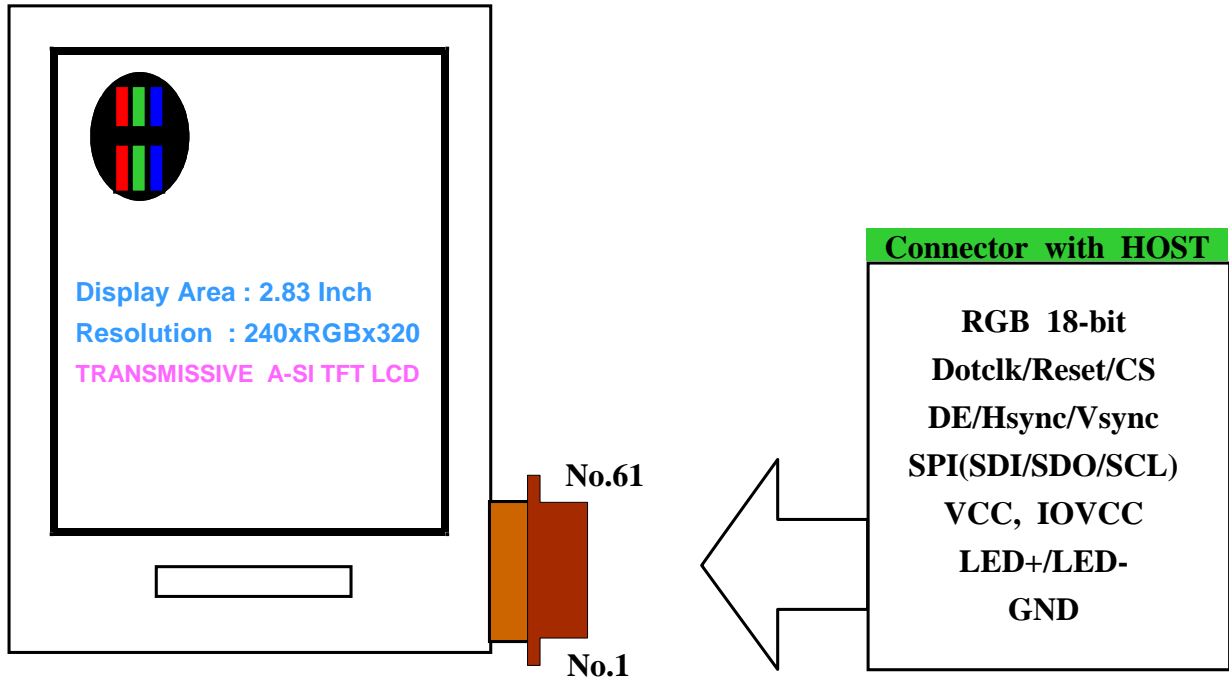

4.2 Back-light Unit

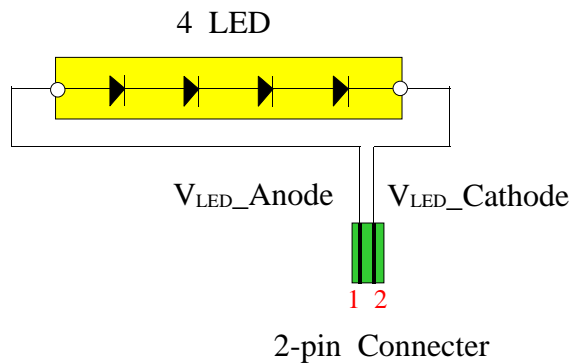

Pin No.	Symbol	I/O
1	LED_ANODE	Anode
2	LED_CATHODE	Cathode

5. Input Terminal Pin Assignment

5.1 TFT-LCD Module (Mating Connector : 61PIN (Part Name:FH23-61S-0.3SHW, HIROSE))

Pin No	Symbol	Description	Remark
1	DE	Data enable	Low active
2	MCLK	Main clock	Rising edge
3	RST	IC Reset	Low active
4	N.C	No connection	
5	GND	Ground	
6	N.C.	No connection	
7	N.C.	No connection	
8	GND	Ground	
9	N.C.	No connection	
10	N.C.	No connection	
11	N.C.	No connection	
12	N.C.	No connection	
13	GND	Ground	
14	N.C	No connection	
15	N.C.	No connection	
16	N.C.	No connection	
17	N.C.	No connection	
18	N.C.	No connection	
19	GND	GROUND	
20	VCC	Logic Power	
21	VCC	Logic Power	
22	N.C.	No connection	
23	N.C.	No connection	
24	N.C	No connection	
25	GND	Ground	
26	N.C.	No connection	
27	N.C	No connection	
28	VCC	Logic Power	
29	PD17	Red data(R5)	(1)
30	PD16	Red data(R4)	
31	PD15	Red data(R3)	
32	PD14	Red data(R2)	
33	PD13	Red data(R1)	
34	PD12	Red data(R0)	(1)

Preliminary Specification

Pin No	Symbol	Description	Remark
35	PD11	Green data(G5)	(1)
36	PD10	Green data(G4)	
37	PD9	Green data(G3)	
38	PD8	Green data(G2)	
39	PD7	Green data(G1)	
40	PD6	Green data(G0)	(1)
41	PD5	Blue data(B5)	(1)
42	PD4	Blue data(B4)	
43	PD3	Blue data(B3)	
44	PD2	Blue data(B2)	
45	PD1	Blue data(B1)	
46	PD0	Blue data(B0)	(1)
47	N.C.	No connection	
48	CS	Chip select	Low active
49	SCL	SPI / Write clock	Rising edge
50	SDI	SPI / Data input	(2)
51	SDO	SPI / Data output	
52	HSYNC	Horizontal sync signal	Low active
53	GND	Ground	
54	N.C.	No connection	
55	N.C.	No connection	
56	VSYNC	Vertical sync signal	Low active
57	LED+	LED ANODE	
58	LED+	LED ANODE	
59	LED-	LED CATHODE	
60	LED-	LED CATHODE	
61	N.C.	No connection	

Remark (1) LSB : B0, G0, R0

MSB : B5, G5, R5

Unused pins(PD12, PD0) must be connected to VCC or GND level

(2) We need a "SPI" for initial power setting of driver IC including the power block

5.2 Back-Light Unit (Connector : 2 pin FPC Solder type)

Pin No.	Symbol	Function
1	LED+	LED Anode
2	LED-	LED Cathode

5.3 Input Signal, Basic Display Colors and Gray Scale of Each Colors

COLOR	DISPLAY	DATA SIGNAL																GRAY SCALE LEVEL	
		RED					GREEN					BLUE							
		R0	R1	R2	R3	R4	R5	G0	G1	G2	G3	G4	G5	B0	B1	B2	B3		B4
BASIC COLOR	BLACK	0	0	0	0	0	0	0	0	0	0	0	0	0	0	0	0	0	-
	BLUE	0	0	0	0	0	0	0	0	0	0	0	0	1	1	1	1	1	-
	GREEN	0	0	0	0	0	0	1	1	1	1	1	1	0	0	0	0	0	-
	CYAN	0	0	0	0	0	0	1	1	1	1	1	1	1	1	1	1	1	-
	RED	1	1	1	1	1	1	0	0	0	0	0	0	0	0	0	0	0	-
	MAGENTA	1	1	1	1	1	1	0	0	0	0	0	0	1	1	1	1	1	-
	YELLOW	1	1	1	1	1	1	1	1	1	1	1	1	0	0	0	0	0	-
	WHITE	1	1	1	1	1	1	1	1	1	1	1	1	1	1	1	1	1	-
GRAY SCALE OF RED	BLACK	0	0	0	0	0	0	0	0	0	0	0	0	0	0	0	0	0	R0
	DARK ↑	1	0	0	0	0	0	0	0	0	0	0	0	0	0	0	0	0	R1
		0	1	0	0	0	0	0	0	0	0	0	0	0	0	0	0	0	R2
		:	:	:	:	:	:	:	:	:	:	:	:	:	:	:	:	:	R3~R60
	:	:	:	:	:	:	:	:	:	:	:	:	:	:	:	:	:		
	LIGHT ↓	1	0	1	1	1	1	0	0	0	0	0	0	0	0	0	0	0	R61
		0	1	1	1	1	1	0	0	0	0	0	0	0	0	0	0	0	R62
	RED	1	1	1	1	1	1	0	0	0	0	0	0	0	0	0	0	0	R63
GRAY SCALE OF GREEN	BLACK	0	0	0	0	0	0	0	0	0	0	0	0	0	0	0	0	0	G0
	DARK ↑	0	0	0	0	0	0	1	0	0	0	0	0	0	0	0	0	0	G1
		0	0	0	0	0	0	0	1	0	0	0	0	0	0	0	0	0	G2
		:	:	:	:	:	:	:	:	:	:	:	:	:	:	:	:	:	G3~G60
	:	:	:	:	:	:	:	:	:	:	:	:	:	:	:	:	:		
	LIGHT ↓	0	0	0	0	0	0	1	0	1	1	1	1	0	0	0	0	0	G61
		0	0	0	0	0	0	0	1	1	1	1	1	0	0	0	0	0	G62
	GREEN	0	0	0	0	0	0	1	1	1	1	1	1	0	0	0	0	0	G63
GRAY SCALE OF BLUE	BLACK	0	0	0	0	0	0	0	0	0	0	0	0	0	0	0	0	0	B0
	DARK ↑	0	0	0	0	0	0	0	0	0	0	0	0	1	0	0	0	0	B1
		0	0	0	0	0	0	0	0	0	0	0	0	0	1	0	0	0	B2
		:	:	:	:	:	:	:	:	:	:	:	:	:	:	:	:	:	B3~B60
	:	:	:	:	:	:	:	:	:	:	:	:	:	:	:	:	:		
	LIGHT ↓	0	0	0	0	0	0	0	0	0	0	0	0	1	0	1	1	1	B61
		0	0	0	0	0	0	0	0	0	0	0	0	0	1	1	1	1	B62
	BLUE	0	0	0	0	0	0	0	0	0	0	0	0	1	1	1	1	1	B63

Note) Definition of Gray :

Rn : Red Gray, Gn : Green Gray, Bn : Blue Gray (n = Gray level)

Input Signal : 0 = Low level voltage, 1 = High level voltage

※R5,G5,B5 : MSB R0,G0,B0 : LSB

6. Interface Specifications.

6.1 Serial Peripheral interface

RS	R/W	Function
0	0	Sets Index Register
0	1	Read Status
1	0	Writes Instruction
1	1	Reads Instruction

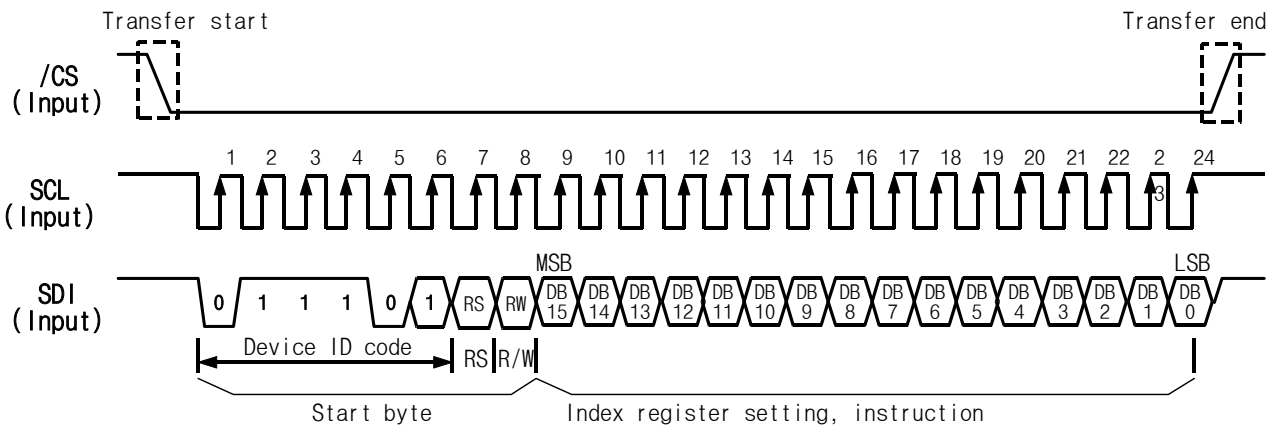

- The data format of instruction is serial 16bit.

6.2 Data Format for 16bit/18bit RGB Interface

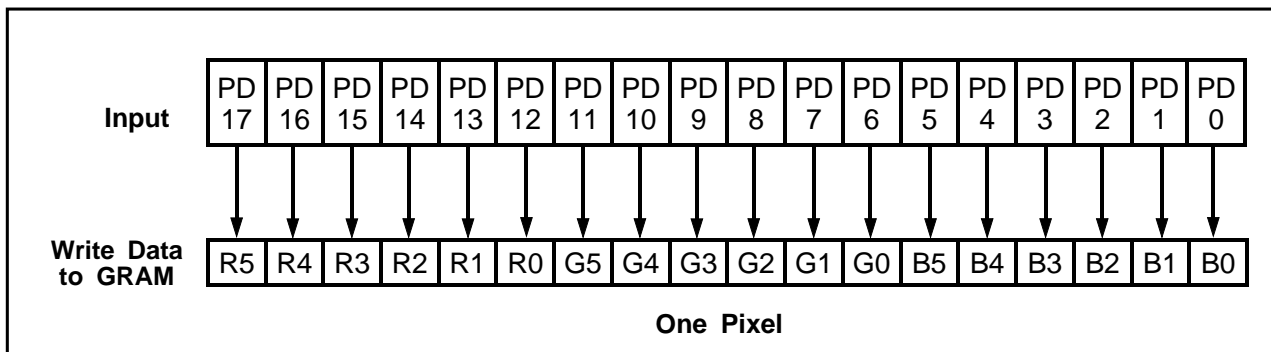

*Note : Unused pins(PD12, PD0) must be connected to VCC or GND level

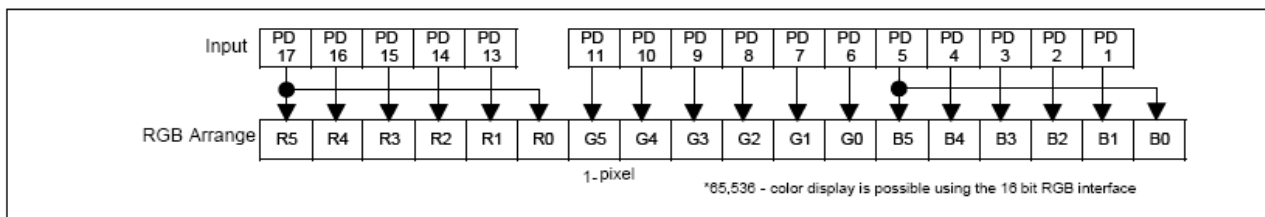

6.3 Input Signal Timing SPEC

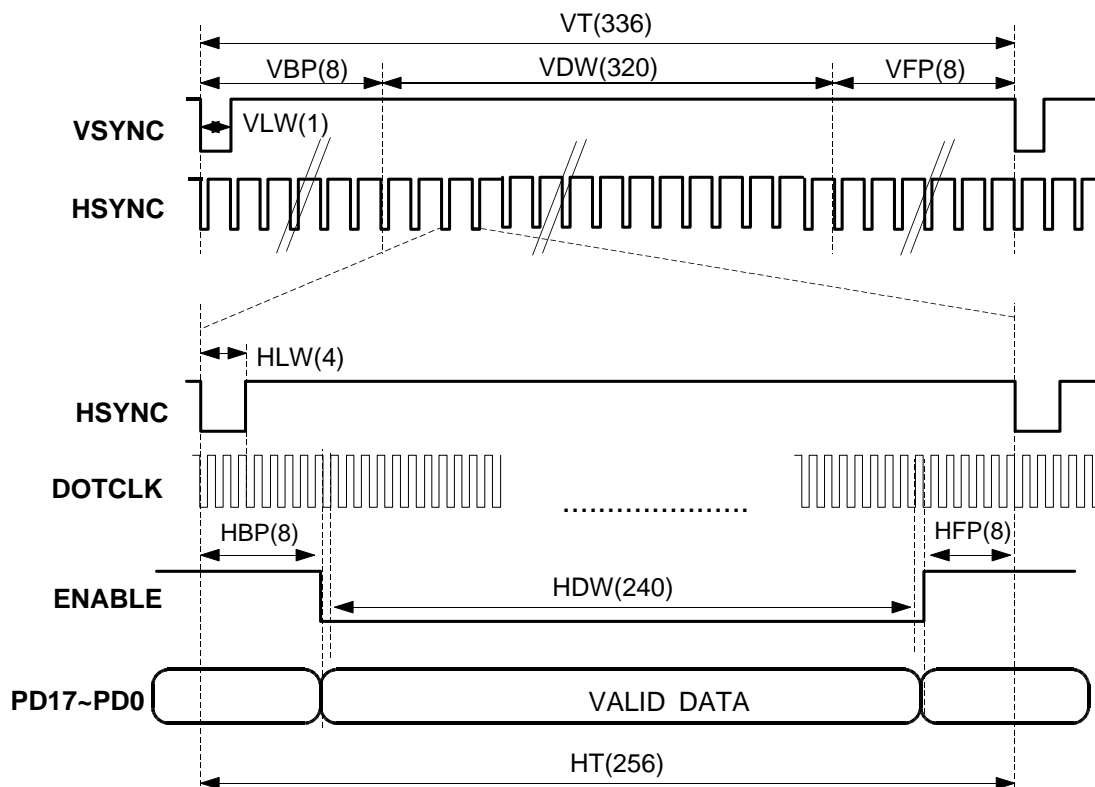
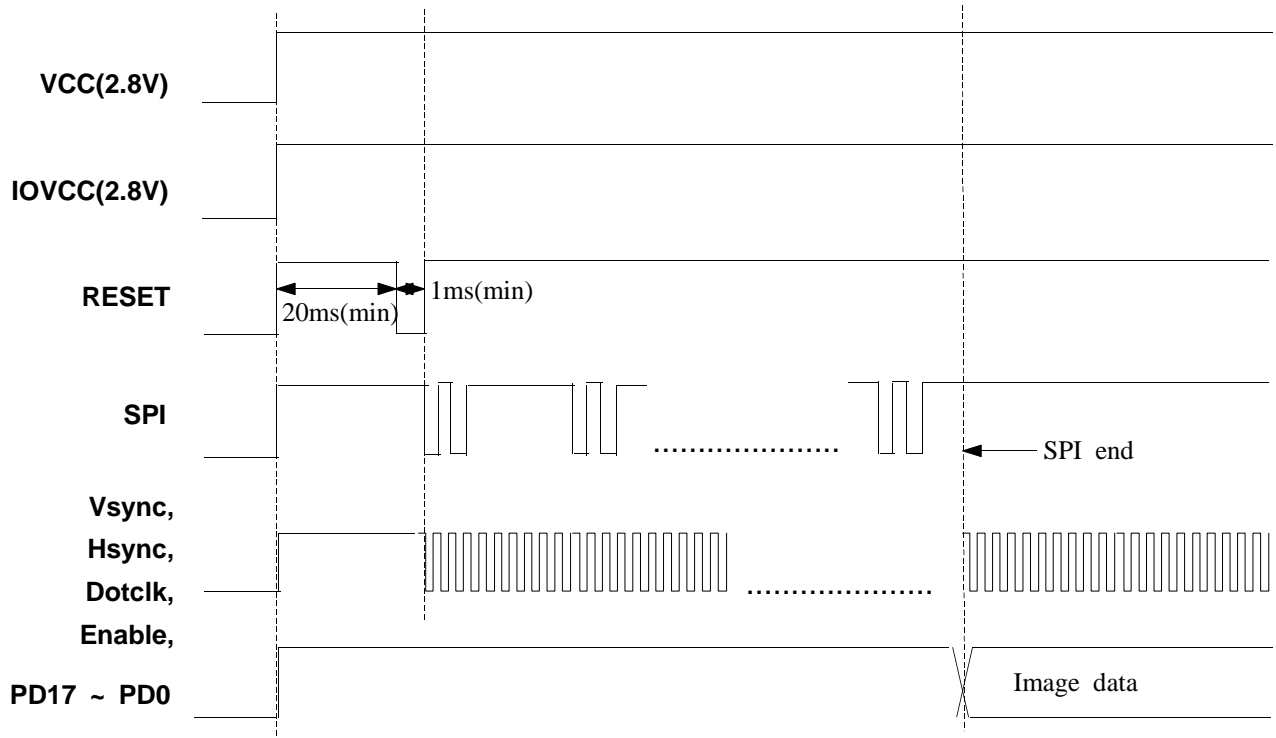

$$\begin{aligned}
 *DOTCLK &= \text{Frame} \times (\text{VDW} + \text{VBP} + \text{VFP}) \times (\text{HDW} + \text{HBP} + \text{HFP}) \\
 &= 80 \text{ Hz} \times \text{VT}(336) \times \text{HT}(256) \\
 &= 6.88\text{MHz}
 \end{aligned}$$

- Note (1) Dot clock signal must be always supplied. Also, there must not be frequency changing
 (2) Horizontal and vertical back porch periods of interface signal must accord with R08h register setting value

6.4 Input Timing Characteristics

Characteristic	Symbol	Min.	Max.	Unit
DOTCLK cycle time	tDCYC	110	194	ns
DOTCLK rise / fall time	tR, tF	-	15	
DOTCLK Pulse width high	tDCHW	40	-	
DOTCLK Pulse width low	tDCLW	40	-	
SYNC setup time	tSYS	30	-	
SYNC hold time	tSYH	30	-	
ENABLE setup time	tENS	15	-	
ENABLE hold time	tENH	7	-	
PD data setup time	tPDS	15	-	
PD data hold time	tPDH	7	-	
Reset low pulse width	tRES	1	-	
Phase difference of sync signal falling edge	tHV	-7	7	tmclk

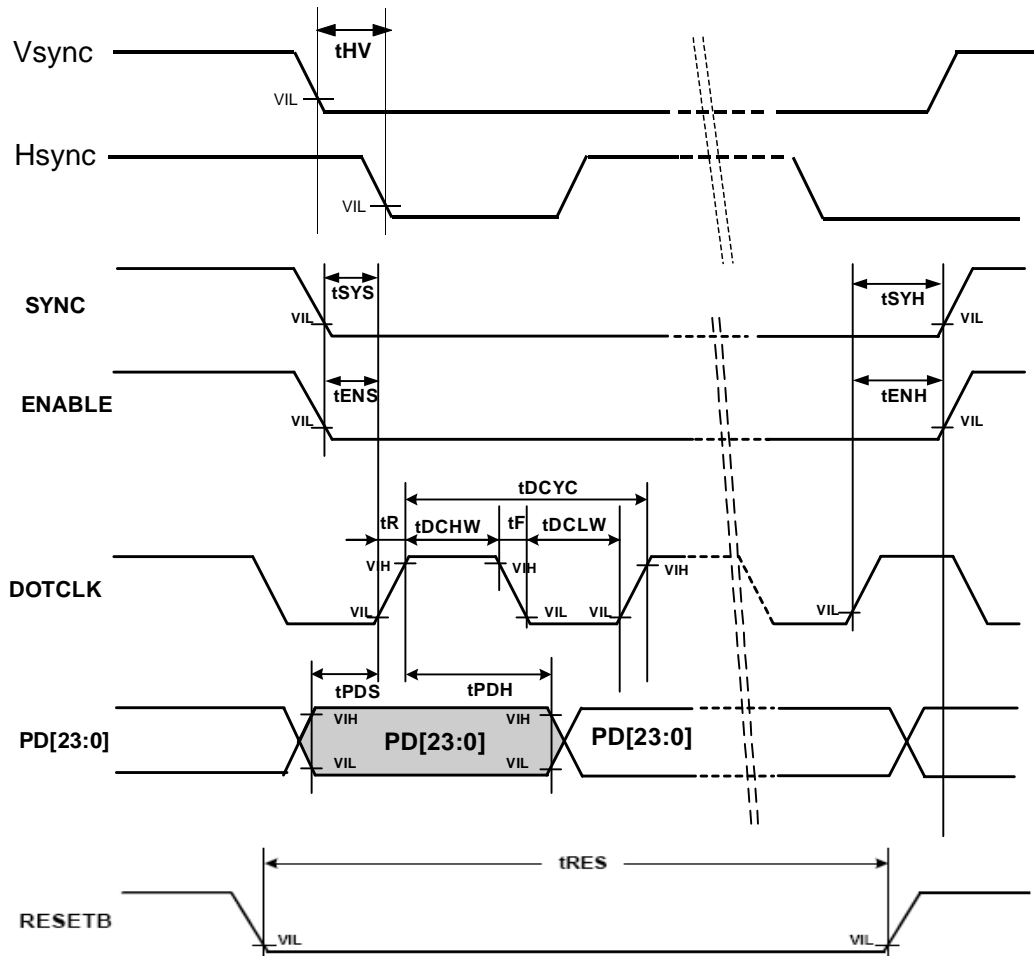

(T_A = -40 to +85 °C)

Characteristic		Symbol	Min.	Max.	Unit
Serial clock cycle time	Write	T _{scycw}	130	-	ns
	Read	T _{scycr}	250	-	
Serial clock rise / fall time		t _R , t _F	-	15	
Pulse width high	Write	t _{SCHW}	50	-	
	Read	t _{SCHR}	110	-	
Pulse width low	Write	t _{SCLW}	50	-	
	Read	t _{SCLR}	110	-	
Chip Select setup time		t _{CSS}	20	-	
Chip Select hold time		t _{CSH}	60	-	
Serial input data setup time		t _{SIDS}	30	-	
Serial input data hold time		t _{SIDH}	30	-	
Serial output data delay time		t _{SODD}	-	130	
Serial output data hold time		t _{SODH}	5	-	

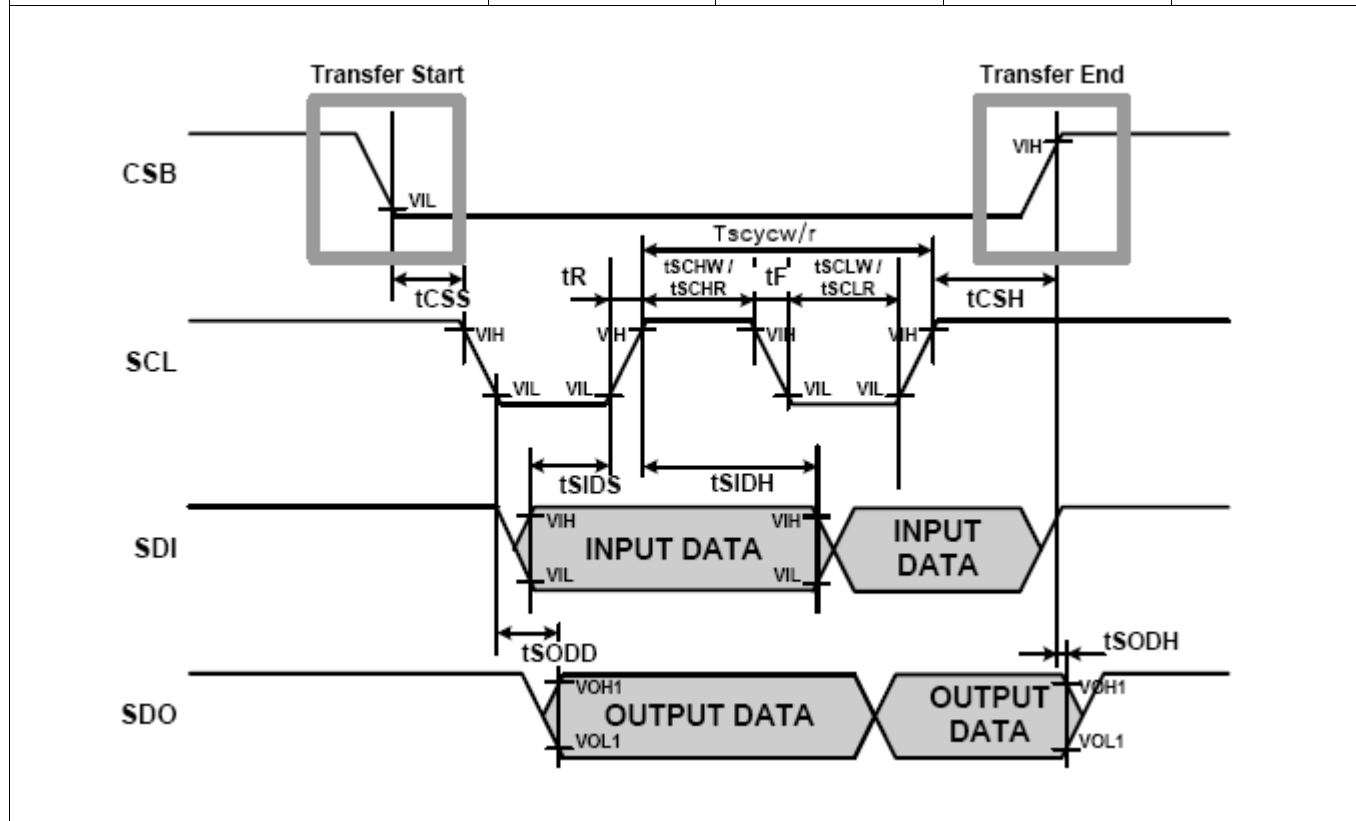

7. Operating Sequence

7-1. Power On/Off Sequence

POWER ON

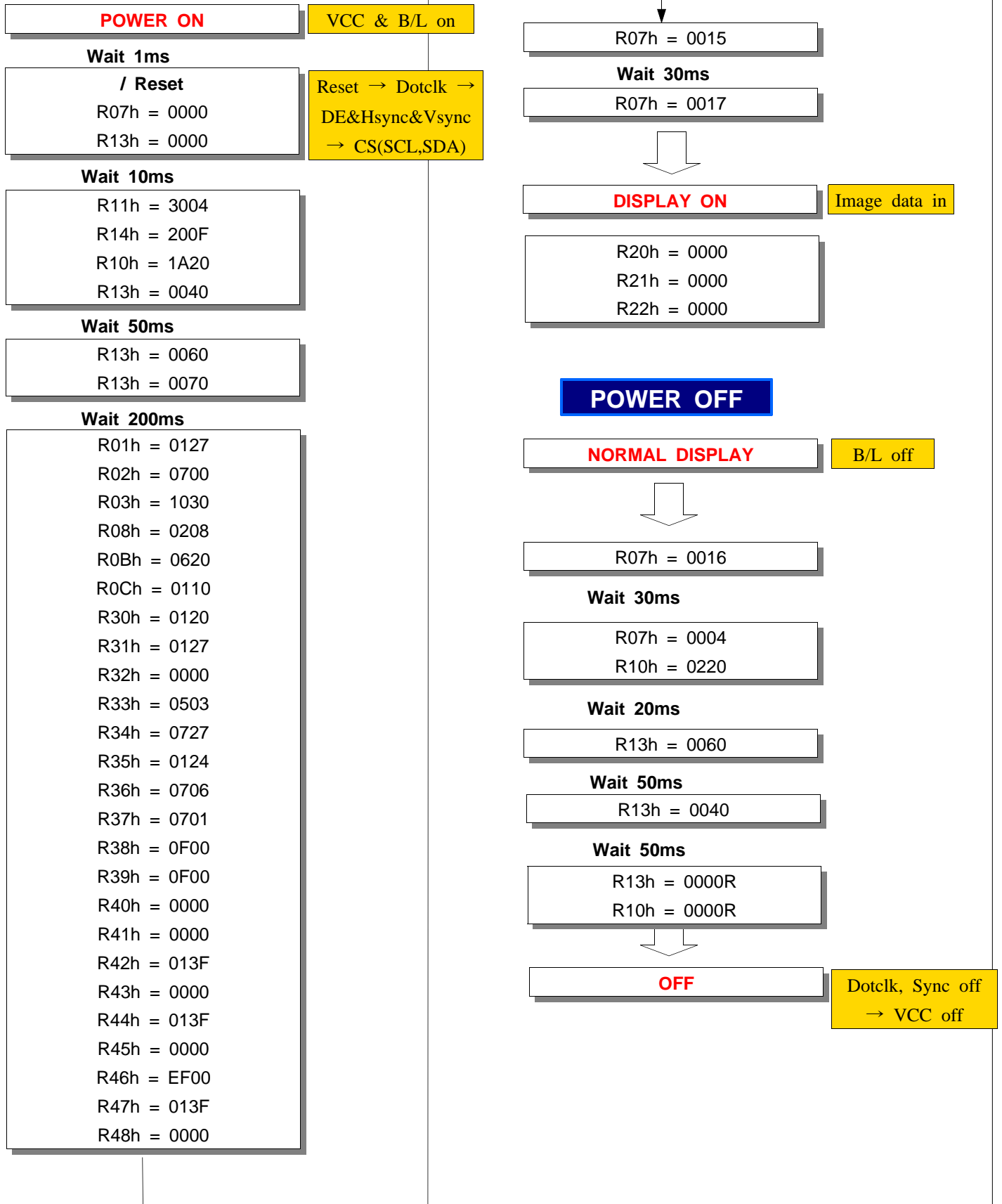

8. Outline Dimensions

8.1 Module Outline Dimensions (Total Assa'y)

- Refer to the Next Page.

NO	PART NAME	CODE NO	SPECIFICATION	Q'TY	SPEC NO	REMARK

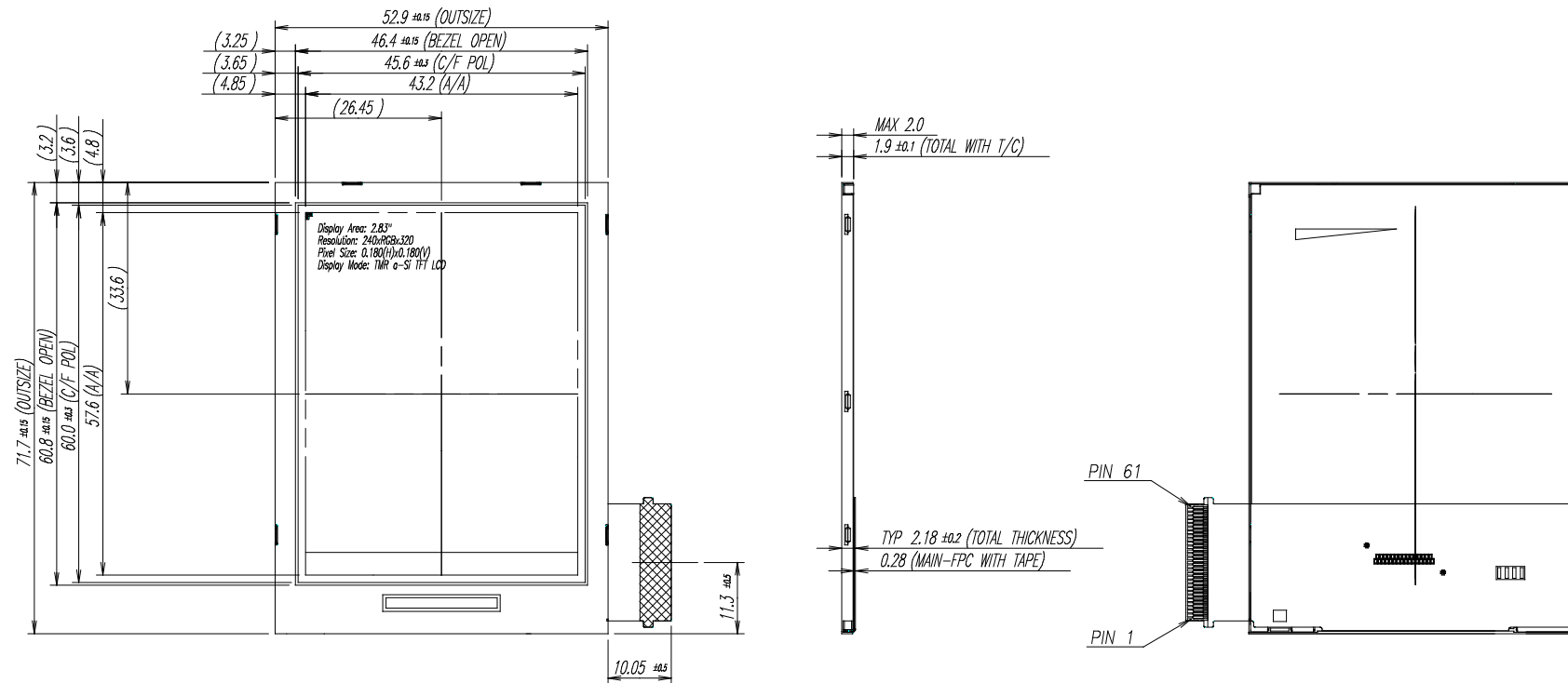

PRELIMINARY

GENERAL TOLERANCE				REV	DATE							
STEP	LEVEL 1	LEVEL 2	LEVEL 3	UNIT	mm	DRA'N BY	DES'D BY	CHK'D BY	APP'D BY	MODEL NAME		
0 < X ≤ 4	±0.05	±0.1	±0.2	SCALE	1/1	S.J.PARK		I.S.LEE	Y.B.JOO	2.83' QVGA(without TSP)		
4 < X ≤ 16	±0.08	±0.15	±0.3	TOLERANCE		'07.01.04		'07.01.04	'07.01.04	PART/SHEET NAME	Outline Dimension	SHEET 1/1
16 < X ≤ 64	±0.12	±0.25	±0.5	LEVEL 3					SPEC. NO	CODE NO.		VER. 000
64 < X ≤ 256	±0.25	±0.4	±0.8	SAMSUNG ELECTRONICS								

9. Packing

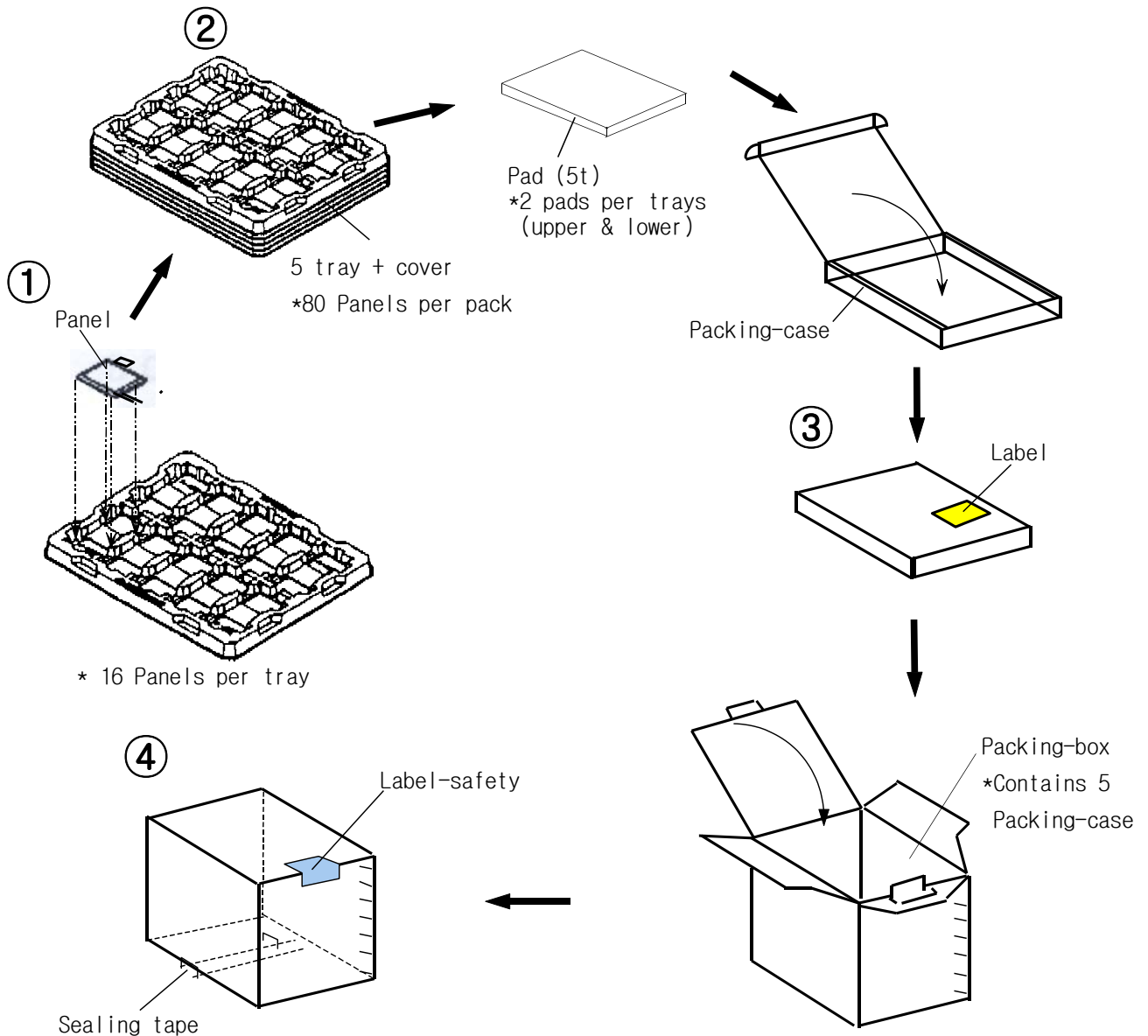

Note (1) Total : Case: Approx. TBD Kg

Box: Approx. TBD Kg

(2) Size : Case: 490(W) x 342(D) x 58(H)

Box: 505(W) x 355(D) x 319(H)

(3) Pad Material : Polyethylene Foam T=3.0

(4) Resistance of tray surface : $10^3 \sim 10^6 \Omega$

(5) ESD of tray surface : 20~100V

(6) Place the panels in the tray facing the direction shown in the figure.

(7) Place 3 tray and cover(empty tray) and pads inside the packing-case.

(8) Place 5 packing-case inside the packing-box.(Affix the label)

(9) Seal the packing-box. Affix the label-safety.

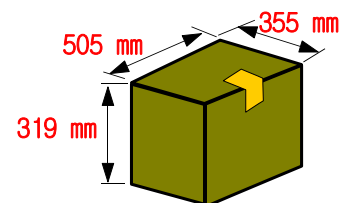

10. Marking & Others

(1) Packing case attach

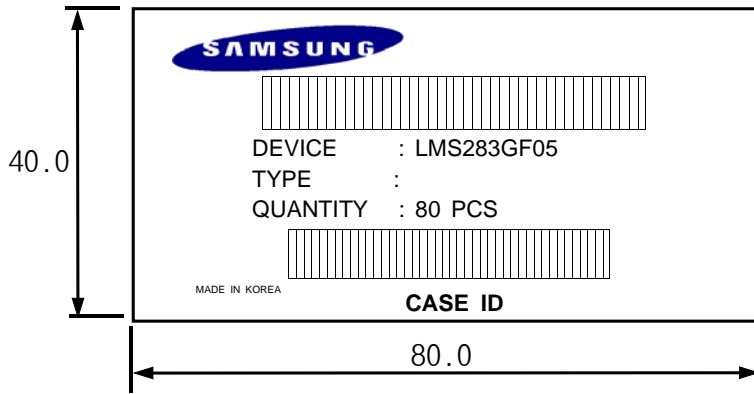

CASE ID : NA 0 00 00001

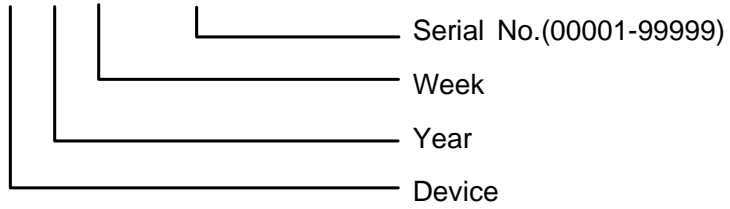

11. Reliability Test Result except Touch Screen Panel

11. 1 Condition

Item		Condition	Sample Size	Test Result
High Temperature Operating Life test		60°C, 160HR	10EA	
Low Temperature Operating Life test		-20°C, 160HR	5EA	
Thermal Humidity Bias		60°C, 90%RH, 160HR	10EA	
High Temperature Storage test		85°C, 160HR	5EA	
Low Temperature Storage test		-40°C, 160HR	5EA	
Thermal Cycle		-40°C ⇔ 85°C	10EA	
Wet Humidity Temperature Storage test		60°C, 90%RH, 160HR	5EA	
Low Pressure(Altitude) Storage test		188mbar, 25±3°C, 72HR	5EA	
Power ON/OFF test		-20°C ~ 70°C	10EA	
ESD	Contact	Shield ±4kV Nude ± 8kV, 150pF/330Ω	5EA	
	Air	Shield ±8kV Nude ±15kV, 150pF/330Ω	5EA	

11. 2 Judgement

- > Main LCD should work under the normal condition.
- > After the temperature and humidity test,
the luminance and CR(Contrast Ratio) should not be changed over 50%
compared with those before the test.

12. General Precautions

12.1 Handling

- (a) When the module is assembled, it should be attached to the system firmly. Be careful not to twist and bend the module.
- (b) Refrain from strong mechanical shock and / or any force to the module. In addition to damage, this may cause improper operation or damage to the module and back-light unit.
- (c) Note that polarizers are very fragile and could be easily damaged. Do not press or scratch the surface harder than a HB pencil lead.
- (d) Wipe off water droplets or oil immediately. If you leave the droplets for a long time, Staining and discoloration may occur.
- (e) If the surface of the polarizer is dirty, clean it using some absorbent cotton or soft cloth.
- (f) The desirable cleaners are water, IPA(Isopropyl Alcohol) or Hexane. Do not use Ketone type materials(ex. Acetone), Ethyl alcohol, Toluene, Ethyl acid or Methyl chloride. It might permanent damage to the polarizer due to chemical reaction.
- (g) If the liquid crystal material leaks from the panel, it should be kept away from the eyes or mouth . In case of contact with hands, legs or clothes, it must be washed away thoroughly with soap.
- (h) Protect the module from static , it may cause damage to the Integrated Gate Circuit.
- (i) Use finger-stalls with soft gloves in order to keep display clean during the incoming inspection and assembly process.
- (j) Do not disassemble the module.
- (k) Protection film for polarizer on the module shall be slowly peeled off just before use so that the electrostatic charge can be minimized.
- (l) Pins of I/F connector shall not be touched directly with bare hands.

12.2 Storage

- (a) Do not leave the panel in high temperature, and high humidity for a long time. It is highly recommended to store the module with temperature from 0 to 35°C and relative humidity of less than 70%.
- (b) Do not store the TFT-LCD module in direct sunlight.
- (c) The module shall be stored in a dark place. It is prohibited to apply sunlight or fluorescent light during the store.

12.3 Operation

- (a) Do not connect, disconnect the module in the "Power On" condition.
- (b) Power supply should always be turned on/off by the item 3.1 "Power on/off sequence"

12.4 Others

- (a) The liquid-crystal is deteriorated by ultraviolet rays. Do not leave it in direct sunlight and strong ultraviolet rays for many hours.
- (b) Avoid condensation of water. It may result in improper operation or disconnection of electrode.
- (c) Do not exceed the absolute maximum rating value. (the supply voltage variation, input voltage variation, variation in part contents and environmental temperature, and so on)
Otherwise the panel may be damaged.
- (d) If the panel displays the same pattern continuously for a long period of time, it can be the situation when the image "Sticks" to the screen.
- (e) This panel has its circuitry FPC on the bottom side and should be handled carefully in order not to be stressed.