



ELECTRONICS

APPROVAL

TO :

DATE : August. 14. 2007

**SAMSUNG TFT-LCD**  
**MODEL NO. : LMS430HF05**

Customer Approval

\_\_\_\_\_  
\_\_\_\_\_  
\_\_\_\_\_  
\_\_\_\_\_

*Any Modification of Spec is not allowed without SEC's permission.*

Approved by :           **S.C. OH**          

**Mobile Display Business Team**  
**LCD Business**  
**Samsung Electronics Co., LTD.**



**Revision History**

Date	Rev. No.	Page	Summary
July.27.2007	000		Rev.000 was first issues.
July.30.2007	001	12	3. Electrical Characteristics
		29	12. Reliability Test Result
Aug. 14.2007	002	8	2.Optical Characteristics (VDD:2.5V->3.3V)
		12	3.Electrical Characteristics (VDD:2.5V->3.3V)
		15	5.Input Terminal Pin Assignment (VDD:2.5V->3.3V)
		18	6.INTERFACE TIMING

## Contents

General Description	----- (4)
1. Absolute Maximum Ratings	----- (6)
1.1 Absolute Ratings Of Environment	
1.2 Electrical Absolute Ratings	
2. Optical Characteristics	----- (8)
3. Electrical Characteristics	----- (12)
3.1 TFT-LCD Module	
3.2 Back-light Unit	
4. Block Diagram	----- (14)
4.1 TFT-LCD Module(Interface System Structure) with Back Light Unit	
4.2 Back-light Unit	
5. Input Terminal Pin Assignment	----- (15)
5.1 Input Signal & Power	
5.2 Input Signal, Basic Display colors and Gray Scale of Each Colors	
5.3 Pixel Format	
6. Interface Timing	----- (18)
6.1 Vertical timing	
6.2 Horizontal timing	
6.3 AC characteristics	
6.4 PON timing characteristics.	
7. Power On/Off Sequence	----- (23)
8. Outline Dimension	----- (24)
9. Packing	----- (25)
10. Marking & Others	----- (26)
11. General Precaution	----- (27)
11.1 Handling	
11.2 Storage	
11.3 Operation	
11.4 Others	
12. Reliability Test Result	----- (29)

## General Description

### \* Description

LMS430HF05 is a TMR(Transmissive with Micro Reflective) type color active matrix TFT (Thin Film Transistor) liquid crystal display (LCD) that uses amorphous silicon TFT as a switching devices. This model is composed of a TFT-LCD module, a driver circuit and a back-light unit.

The resolution of a 4.3" contains 480x272xRGB dots and can display up to 16.7M colors.

### \* Features

- Transmissive with Micro Reflective type and back-light with 10 LEDs are available.
- Visible in outdoor & back-light off condition with reflectivity.
- VA(Normally black) mode.
- 24bit RGB Interface
- DE(Data Enable) & SYNC mode - DE, Vsync, Hsync, DOTCLK

### \* Applications

- Display terminals for PMP(Portable Multimedia Player) , Potable CNS(P-CNS) application products.
- Display terminals for AV application products

**\* General information**

Items	Specification	Unit	Note
Display area	95.04(H) x 53.856(V) (4.3" diagonal)	mm	-
Driver element	a-Si TFT active matrix	-	-
Display colors	16,777,212	colors	-
Number of pixels	480 x 272 x RGB	dot	-
Pixel arrangement	RGB stripe	-	-
Pixel pitch	0.198(H) x 0.198(V)	mm	128ppi
Display mode	Normally black	-	-

**\* Mechanical information**

Item		Min.	Typ.	Max.	Unit	Note
Module size	Horizontal(H)	105.3	105.5	105.7	mm	-
	Vertical(V)	67.0	67.2	67.4	mm	(1)
	Depth(D)	2.7	2.9	3.1	mm	(1)
Weight		40	45	50	g	(2)

Note (1) Not include FPC.

Refer to the Outline Dimension in the "8. Outline Dimension" for further information.

## 1. Absolute Maximum Ratings

### 1.1 Absolute Ratings Of Environment

ITEM	MIN	MAX	REMARK
Storage Temperature	-40℃	85℃	Note(1)
Operating Temperature	-20℃	70℃	Note(2)(3)

Note(1) 90%RH maximum humidity, 60℃ maximum wet-bulb temperature

- (2) When operated at a temperature lower than 0℃, the LCD worked slowly and the screen appeared low-contrast images due to the characteristics of LC(Liquid Crystal).
- (3) If any fixed pattern is displayed on LCD for minutes, image-sticking phenomenon may occur.

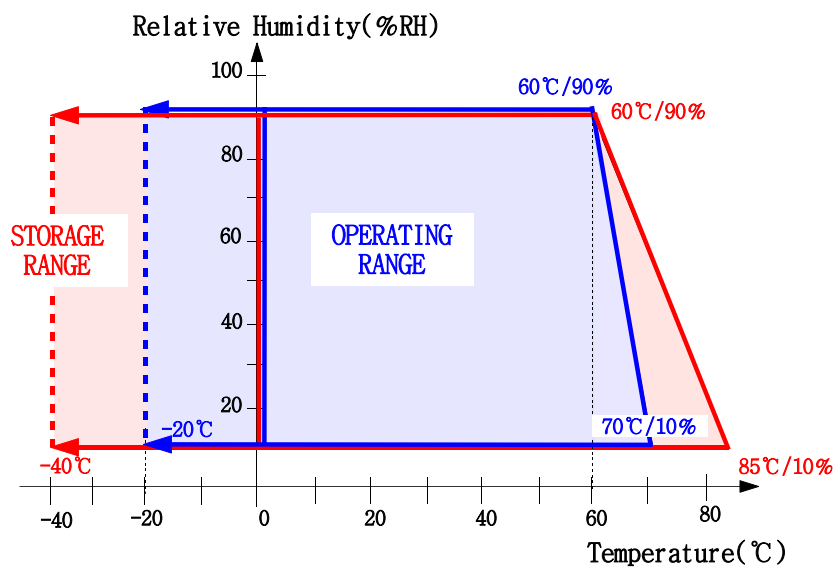

Temperature & Humidity Graph at Absolute Environment

## 1.2 Electrical Absolute Ratings

### (1) TFT-LCD Module

(Ta = 25 ± 2°C, VSS=GND=0)

Item	Symbol	Min.	Max.	Unit	Note
Digital Input voltage	VDD	-0.3	4.6	V	-

### (2) Back-Light Unit

(Ta = 25 ± 2°C)

Item	Symbol	Min.	Max.	Unit.	Note
Current	I <sub>B</sub>	-	25	mA	(1)

Note (1) Permanent damage to the device may occur if maximum values are exceeded or reverse voltage is loaded.

Functional operation should be restricted to the conditions described under normal operating conditions.

## 2. Optical Characteristics

The following items are measured under stable conditions. The optical characteristics should be measured in a dark room or equivalent state with the methods shown in Note (1).

Measuring equipment : SR-3, BM-7, EZ-Contrast

(Ta = 25 ± 2°C, VDD=3.3V, fv= 60Hz, fDCLK=9.2MHz, IL = 22mA)

Item		Symbol	Condition	Min.	Typ.	Max.	Unit	Note
Contrast ratio (Center point)		C/R	NOTE (1)  Θ = 0 Φ = 0 Normal Viewing Angle  B/L On	500	900	-	-	(2) SR-3
Luminance of white (Center point)		YL		370	500	-	cd/m <sup>2</sup>	(3) SR-3
Response time	Rising	T <sub>R</sub>		-	17	22	msec	(4) BM-7
	Falling	T <sub>F</sub>		-	15	20		
Color chromaticity (CIE 1931)	White	W <sub>X</sub>		0.26	0.31	0.36	-	(5) SR-3
		W <sub>Y</sub>		0.28	0.33	0.38		
	Red	R <sub>X</sub>		0.55	0.60	0.65		
		R <sub>Y</sub>		0.31	0.36	0.41		
	Green	G <sub>X</sub>		0.31	0.36	0.41		
		G <sub>Y</sub>		0.51	0.56	0.61		
Blue	B <sub>X</sub>	0.10	0.15	0.20				
	B <sub>Y</sub>	0.06	0.11	0.16				
Viewing angle	Hor.	Θ <sub>L</sub>	C/R ≥ 10 B/L On	70	80	-	Degrees	(6) EZ-Contrast
		Θ <sub>R</sub>		70	80	-		
	Ver.	Φ <sub>H</sub>		70	80	-		
		Φ <sub>L</sub>		70	80	-		



Note (1) Test Equipment Setup

After stabilizing and leaving the panel alone at a given temperature for 10 min , the measurement should be executed. Measurement should be executed in a stable, windless, and dark room. 10 min after lighting the back-light. This should be measured in the center of screen.

Environment condition :  $T_a = 25 \pm 2 \text{ }^\circ\text{C}$

Back-Light On condition

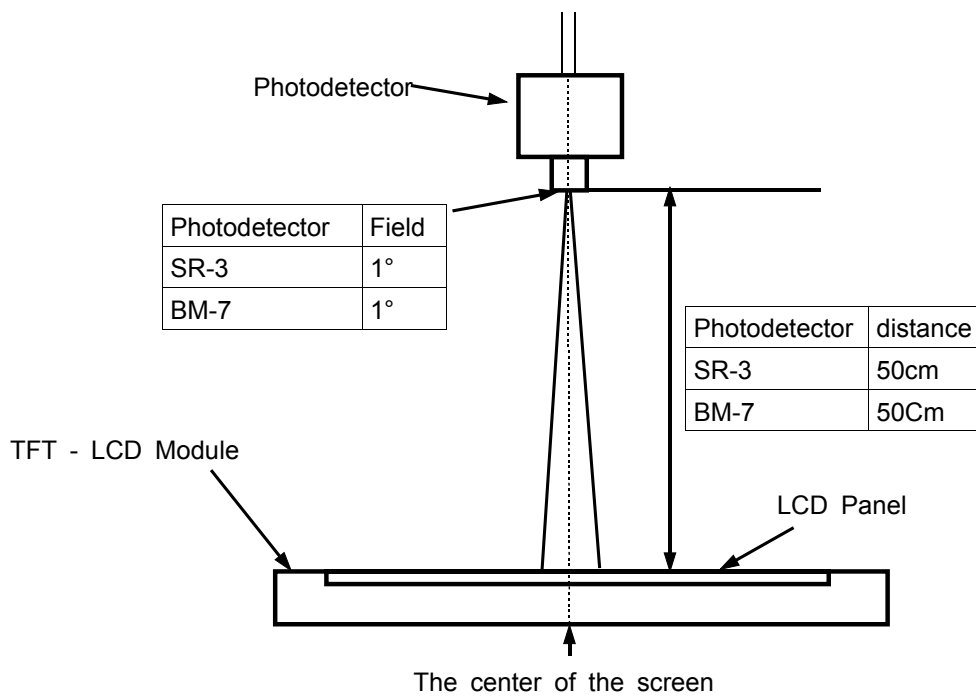

Note (2) Definition of Contrast Ratio (C/R) : Ratio of gray max (Gmax) & gray min (Gmin) at the center point

$$CR = \frac{G \text{ max}}{G \text{ min}}$$

\* Gmax : Luminance with all pixels white  
\* Gmin : Luminance with all pixels black

Note (3) Definition of Luminance of White : Luminance of white at the center point(@ ③).

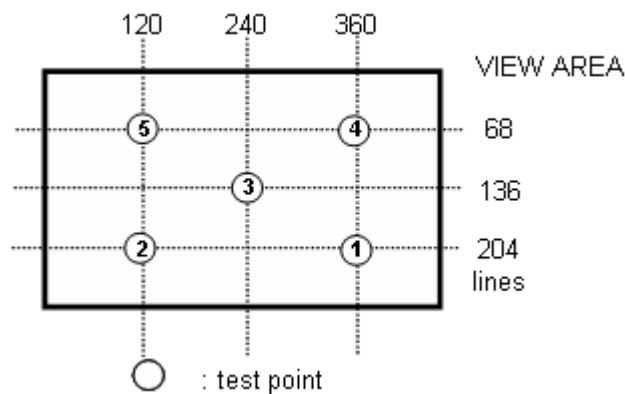

Note (4) Definition of Response time : Sum of Tr ,Tf

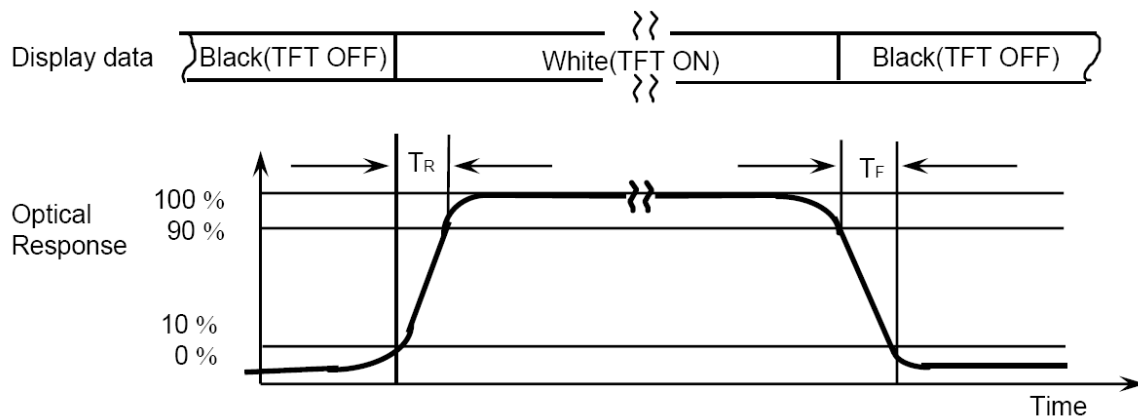

Note (5) Definition of Color Chromaticity (CIE 1931)

Color coordinate of white & red, green, blue at center point(@ ③).

Note (6) Definition of Viewing Angle : Viewing angle range ( $CR \geq 10$  )

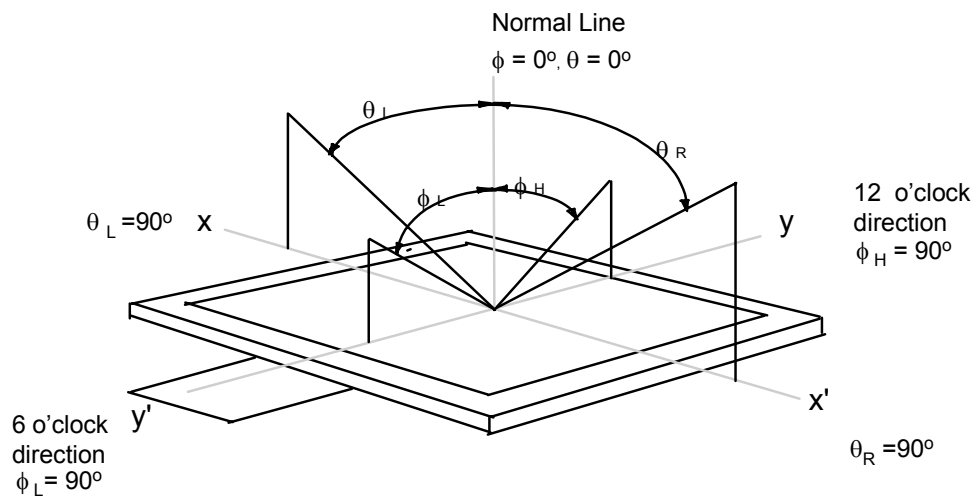

### 3. Electrical Characteristics

#### 3.1 TFT-LCD Module

Ta = 25 ± 2°C

ITEM	Symbol	Min.	Typ.	Max.	Unit	Note
Logic supply voltage	VDD	2.9	3.3	3.5	V	
Input "High" level voltage	VIH	0.7*VDD	-	VDD	V	
Input "Low" level voltage	VIL	0	-	0.3*VDD	V	
Vsync Frequency	f <sub>v</sub>	-	60	70	Hz	
Hsync Frequency	f <sub>H</sub>	-	17.28	-	kHz	
Main Frequency	f <sub>DCLK</sub>	-	9.2	15.0	MHZ	
Power Dissipation	White	-	100	120	mW	(1), (2)
	Black		85	105	mW	

Note (1). f<sub>v</sub>=60Hz, f<sub>DCLK</sub>=9.2MHZ, VDD=3.3V

Note (2). Power Dissipation check pattern

a) White Pattern

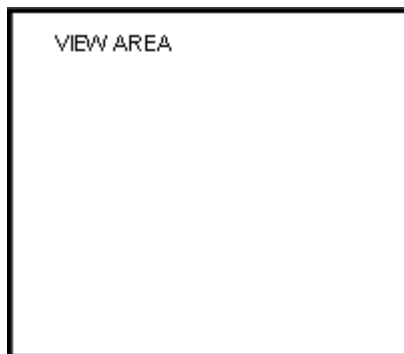

b) Black Pattern

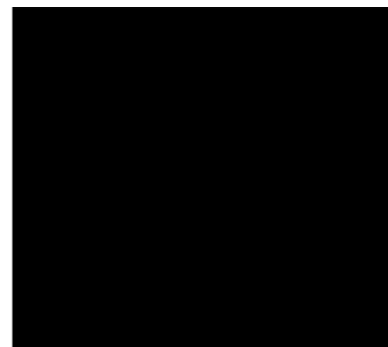

### 3.2 Back-Light unit

The back-light system is an edge-lighting type with 10 white LED(Light Emitting Diode)s.

(Ta=25 ± 2°C)

Item	Symbol	Min.	Typ.	Max.	Unit	Note
LEDs Current	$I_B$	-	22	23	mA	(1)
Power Consumption	$P_{BL}$	-	730	-	mW	(2)

Note (1) 10 LEDs serial type.

(2) Where  $I_B = 22 \text{ mA}$ ,  $V_B = P_{BL} / I_B$

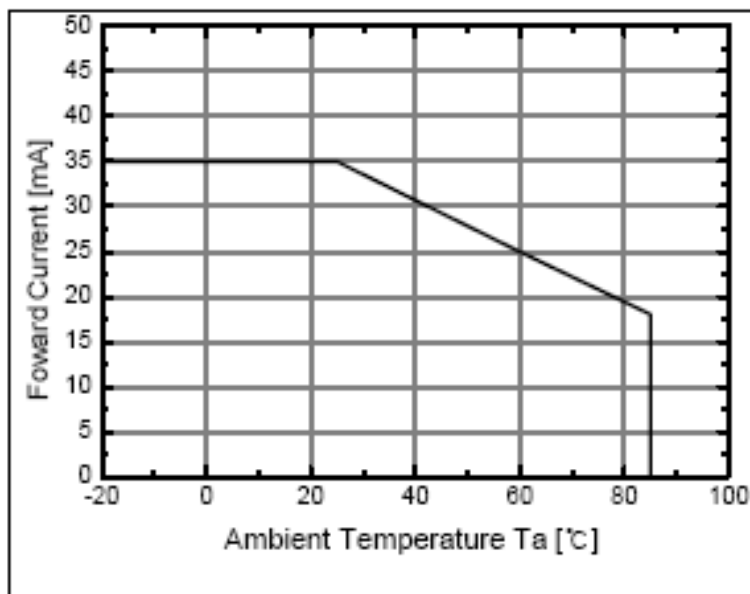

### 4. Block Diagram

#### 4.1 TFT-LCD Module (Interface System Structure) with Back Light Unit

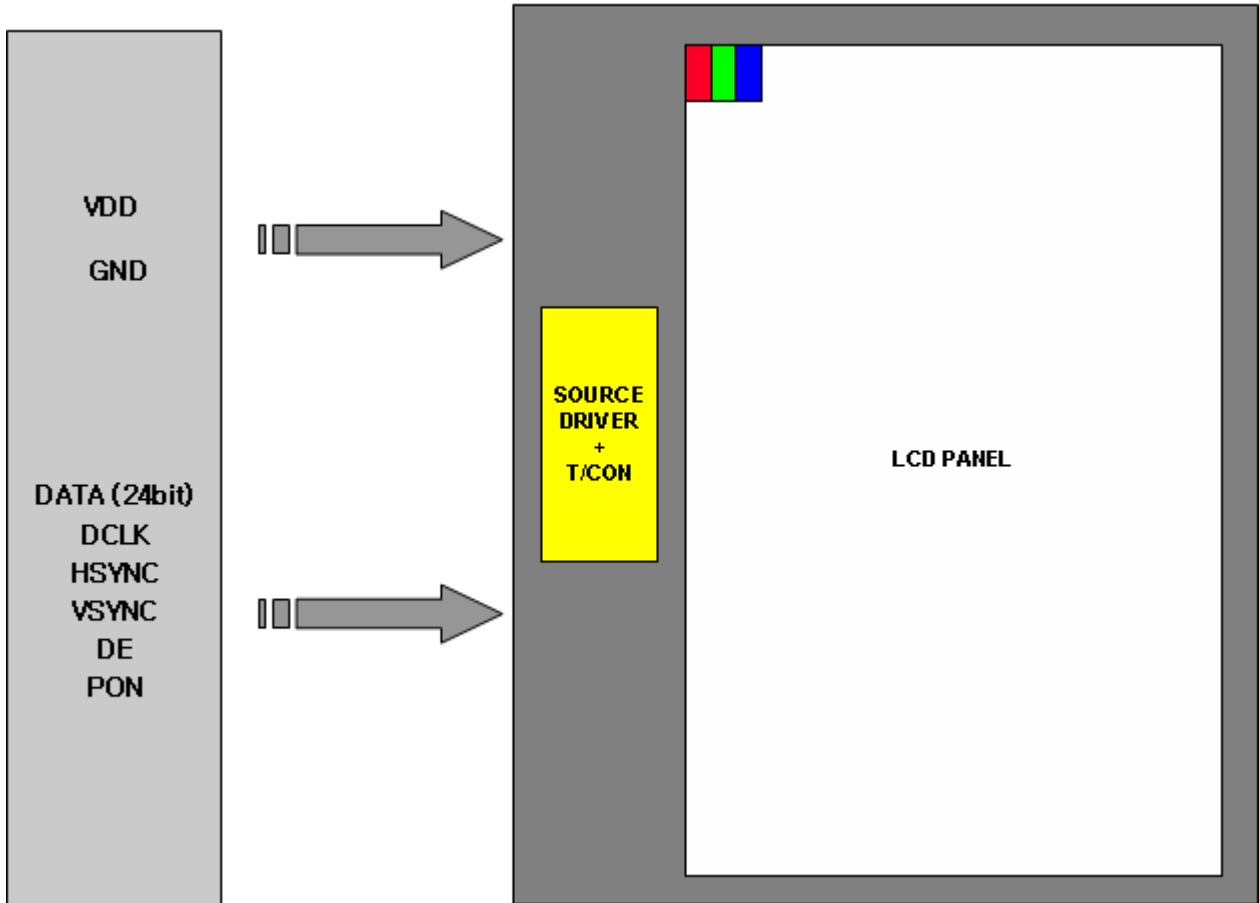

#### 4.2 Back-light Unit (Connector : 2 pin FPC Solder type)

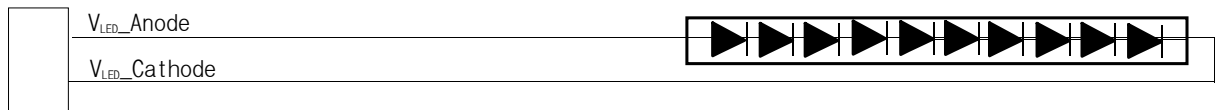

## 5. Input Terminal Pin Assignment

### 5.1 Input Signal & Power (Connector type : 45Pin / 0.5mm pitch)

- Hirose : FH12 series

Pin No.	Symbol	Description	Remark	Pin No.	Symbol	Description	Remark
1	VSS	Ground		24	B1	Blue data	
2	VSS	Ground		25	B2	Blue data	
3	VDD	Power Supply	3.3V	26	B3	Blue data	
4	VDD	Power Supply	3.3V	27	B4	Blue data	
5	VSS	Ground		28	B5	Blue data	
6	VSS	Ground		29	B6	Blue data	
7	R0	Red data (LSB)		30	B7	Blue data (MSB)	
8	R1	Red data		31	VSS	Ground	
9	R2	Red data		32	PCLK	dot clock	
10	R3	Red data		33	PON	Disply on/off	
11	R4	Red data		34	HSYNC	Horizontal Sync	
12	R5	Red data		35	YSYNC	Vertical Sync	
13	R6	Red data		36	DE	Data Enable	
14	R7	Red data (MSB)		37	VSS	Ground	
15	G0	Green data (LSB)		38	VSS	Ground	
16	G1	Green data		39	LED-	LED Cathode	
17	G2	Green data		40	VSS	Ground	
18	G3	Green data		41	N/C	No Connect	
19	G4	Green data		42	LED+	LED Anode	
20	G5	Green data		43	N/C	No Connect	
21	G6	Green data		44	VSS	Ground	
22	G7	Green data (MSB)		45	VSS	Ground	
23	B0	Blue data(LSB)					

### 5.2 Input Signal, Basic Display Colors and Gray Scale of Each Colors

COLOR	DISPLAY	DATA SIGNAL																								GRAY SCALE LEVEL
		RED							GREEN							BLUE										
		R0	R1	R2	R3	R4	R5	R6	R7	G0	G1	G2	G3	G4	G5	G6	G7	B0	B1	B2	B3	B4	B5	B6	B7	
BASIC COLOR	BLACK	0	0	0	0	0	0	0	0	0	0	0	0	0	0	0	0	0	0	0	0	0	0	0	0	-
	BLUE	0	0	0	0	0	0	0	0	0	0	0	0	0	0	0	0	1	1	1	1	1	1	1	1	-
	GREEN	0	0	0	0	0	0	0	0	1	1	1	1	1	1	1	1	0	0	0	0	0	0	0	0	-
	CYAN	0	0	0	0	0	0	0	0	1	1	1	1	1	1	1	1	1	1	1	1	1	1	1	1	-
	RED	1	1	1	1	1	1	1	1	0	0	0	0	0	0	0	0	0	0	0	0	0	0	0	0	-
	MAGENTA	1	1	1	1	1	1	1	1	0	0	0	0	0	0	0	0	1	1	1	1	1	1	1	1	-
	YELLOW	1	1	1	1	1	1	1	1	1	1	1	1	1	1	1	1	0	0	0	0	0	0	0	0	-
	WHITE	1	1	1	1	1	1	1	1	1	1	1	1	1	1	1	1	1	1	1	1	1	1	1	1	-
GRAY SCALE OF RED	BLACK	0	0	0	0	0	0	0	0	0	0	0	0	0	0	0	0	0	0	0	0	0	0	0	R0	
	DARK ↑	1	0	0	0	0	0	0	0	0	0	0	0	0	0	0	0	0	0	0	0	0	0	0	R1	
		0	1	0	0	0	0	0	0	0	0	0	0	0	0	0	0	0	0	0	0	0	0	0	R2	
		:	:	:	:	:	:	:	:	:	:	:	:	:	:	:	:	:	:	:	:	:	:	:	R3~R252	
		:	:	:	:	:	:	:	:	:	:	:	:	:	:	:	:	:	:	:	:	:	:	:		
	LIGHT ↓	1	0	1	1	1	1	1	1	0	0	0	0	0	0	0	0	0	0	0	0	0	0	0	R253	
		0	1	1	1	1	1	1	1	0	0	0	0	0	0	0	0	0	0	0	0	0	0	0	R254	
	RED	1	1	1	1	1	1	1	1	0	0	0	0	0	0	0	0	0	0	0	0	0	0	0	R255	
GRAY SCALE OF GREEN	BLACK	0	0	0	0	0	0	0	0	0	0	0	0	0	0	0	0	0	0	0	0	0	0	0	G0	
	DARK ↑	0	0	0	0	0	0	0	0	1	0	0	0	0	0	0	0	0	0	0	0	0	0	0	G1	
		0	0	0	0	0	0	0	0	0	1	0	0	0	0	0	0	0	0	0	0	0	0	0	G2	
		:	:	:	:	:	:	:	:	:	:	:	:	:	:	:	:	:	:	:	:	:	:	:	G3~G252	
		:	:	:	:	:	:	:	:	:	:	:	:	:	:	:	:	:	:	:	:	:	:	:		
	LIGHT ↓	0	0	0	0	0	0	0	0	1	0	1	1	1	1	1	1	0	0	0	0	0	0	0	G253	
		0	0	0	0	0	0	0	0	0	1	1	1	1	1	1	1	0	0	0	0	0	0	0	G254	
	GREEN	0	0	0	0	0	0	0	0	1	1	1	1	1	1	1	1	0	0	0	0	0	0	0	G255	
GRAY SCALE OF BLUE	BLACK	0	0	0	0	0	0	0	0	0	0	0	0	0	0	0	0	0	0	0	0	0	0	0	B0	
	DARK ↑	0	0	0	0	0	0	0	0	0	0	0	0	0	0	0	0	1	0	0	0	0	0	0	B1	
		0	0	0	0	0	0	0	0	0	0	0	0	0	0	0	0	1	0	0	0	0	0	0	B2	
		:	:	:	:	:	:	:	:	:	:	:	:	:	:	:	:	:	:	:	:	:	:	:	B3~B252	
		:	:	:	:	:	:	:	:	:	:	:	:	:	:	:	:	:	:	:	:	:	:	:		
	LIGHT ↓	0	0	0	0	0	0	0	0	0	0	0	0	0	0	0	0	1	0	1	1	1	1	1	B253	
		0	0	0	0	0	0	0	0	0	0	0	0	0	0	0	0	0	1	1	1	1	1	1	B254	
	BLUE	0	0	0	0	0	0	0	0	0	0	0	0	0	0	0	0	1	1	1	1	1	1	1	B255	

Note) Definition of Gray :

Rn : Red Gray, Gn : Green Gray, Bn : Blue Gray (n = Gray level)

Input Signal : 0 = Low level voltage, 1 = High level voltage



5.3 PIXEL FORMAT

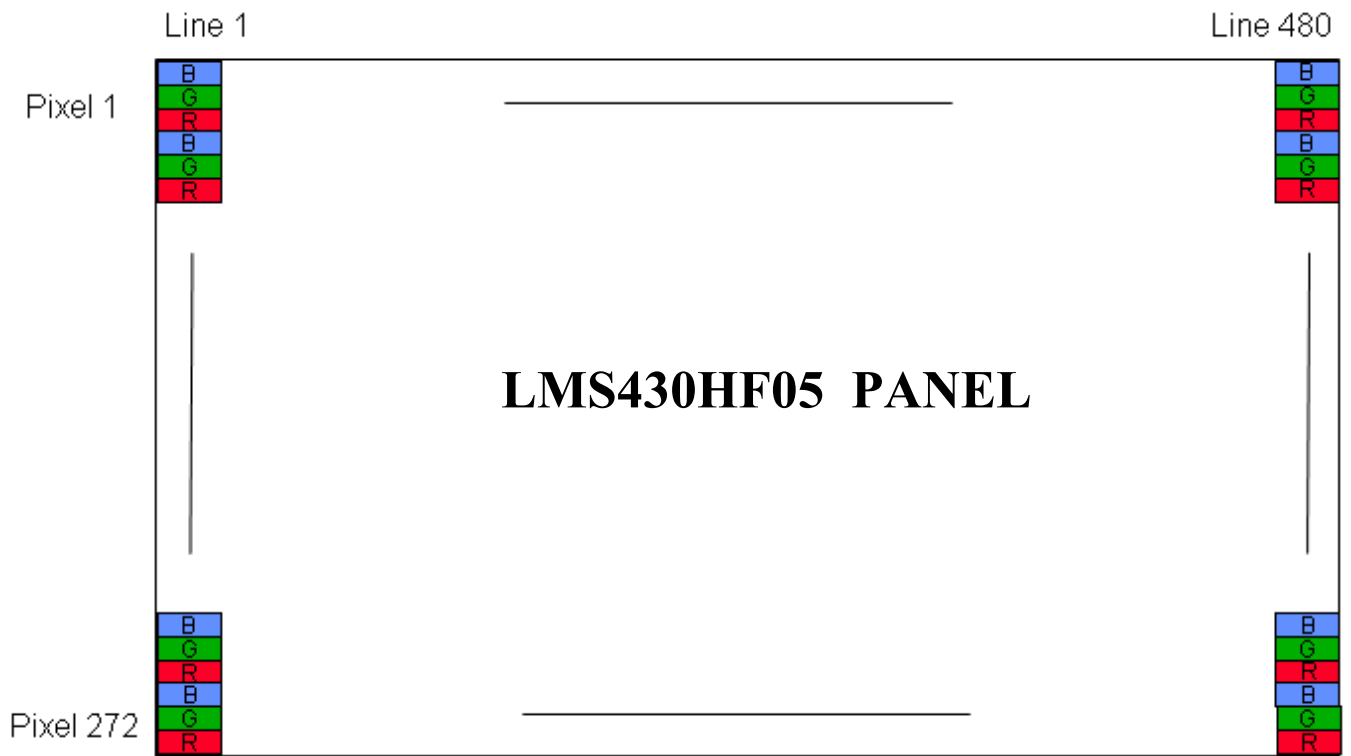

## 6. INTERFACE TIMING

### 6.1 Vertical timing

Signal	Symbol	Min.	Typ.	Max.	Unit	Note
Frame Frequency	fFRM	-	60	70	Hz	
VSYNC(Frame) Period	VCYC	248	288	335	H	
VSYNC Low width	VLW	1	10	-	H	
Vertical Display Period	VDP		272	-	H	
Vertical Back porch	VBP	-	12	-	H	
Vertical Front porch	VFP	2	4	-	H	

### 6.2 Horizontal timing

Signal	Symbol	Min.	Typ.	Max.	Unit	Note
HSYNC(1H) Period	HCYC	490	533	605	DOTCLK	
HSYNC Low width	HLW	4	41	-	DOTCLK	
Horizontal Display Period	HDP	-	480	-	DOTCLK	
Horizontal Back porch	HBP	8	45	-	DOTCLK	
Horizontal Front porch	HFP	2	8	-	DOTCLK	
DOTCLK Frequency	f <sub>DOTCLK</sub>	-	9.2	15	MHz	@fFRM=60Hz

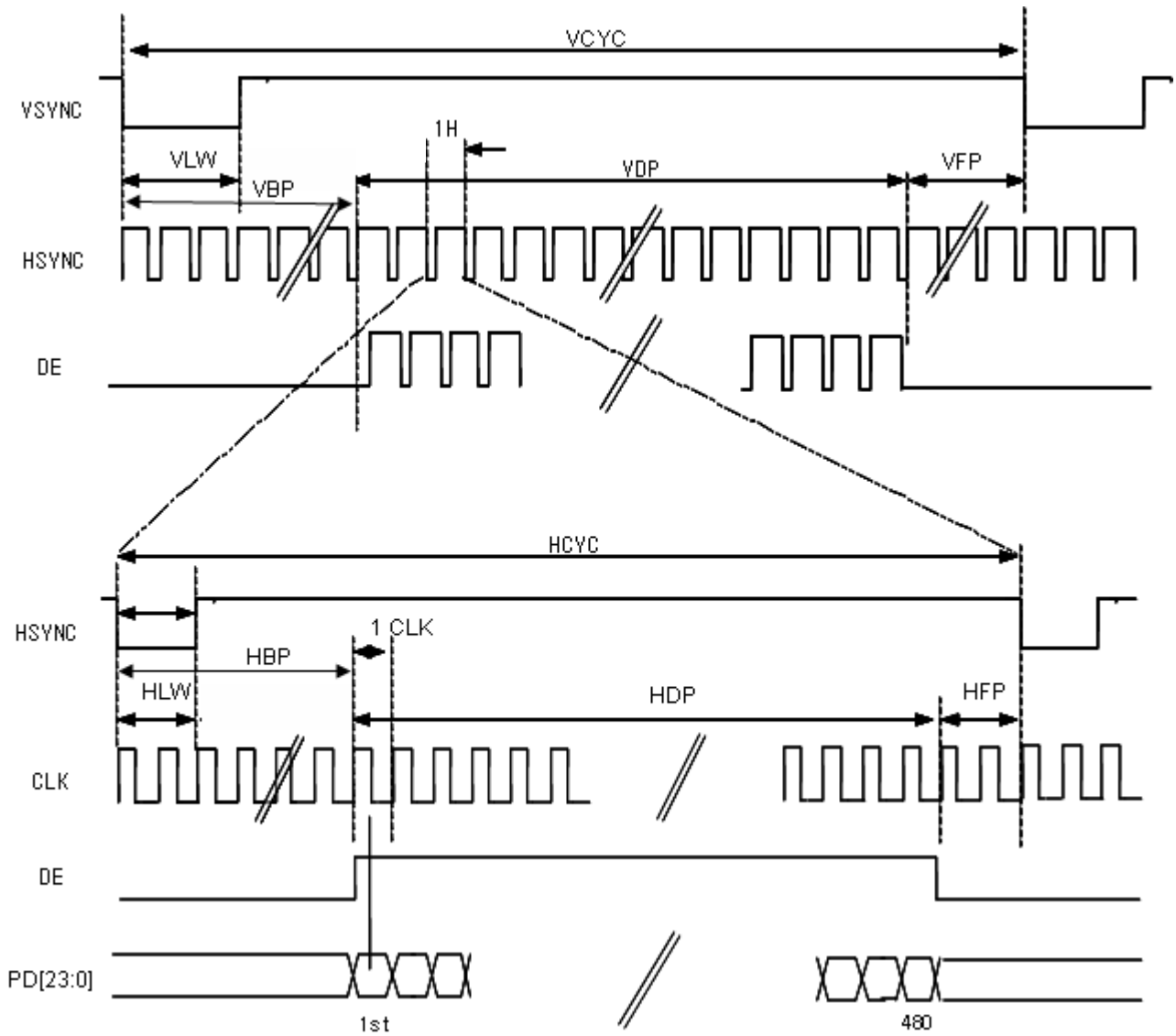

### 6.3 AC characteristics

※ Operating at VDD=2.25~2.9V , Ta = -40°C~+85°C

Parameter	Symbol	Min.	Typ.	Max.	Unit
VSYNC,HSYNC setup time	$t_{SYNCS}$	10	-	-	ns
ENABLE (DE) setup time	$t_{ENS}$	10	-	-	
ENABLE (DE) hold time	$t_{ENH}$	10	-	-	
DOTCLK "Low" level pulse width	$P_{WDL}$	25	-	-	
DOTCLK "High" level pulse width	$P_{WDH}$	25	-	-	
DOTCLK cycle time	$t_{CYCD}$	66.7	-	-	
Data setup time	$t_{PDS}$	10	-	-	
Data hold time	$t_{PDH}$	10	-	-	
DOTCLK,VSYNC,HSYNC clock rise/fall time	$t_{rgrb}$ $t_{rgbf}$	-	-	5	

※ Operating at VDD=2.9~3.5V , Ta = -40°C~+85°C

Parameter	Symbol	Min.	Typ.	Max.	Unit
VSYNC,HSYNC setup time	$t_{SYNCS}$	10	-	-	ns
ENABLE (DE) setup time	$t_{ENS}$	10	-	-	
ENABLE (DE) hold time	$t_{ENH}$	10	-	-	
DOTCLK "Low" level pulse width	$P_{WDL}$	25	-	-	
DOTCLK "High" level pulse width	$P_{WDH}$	25	-	-	
DOTCLK cycle time	$t_{CYCD}$	66.7	-	-	
Data setup time	$t_{PDS}$	10	-	-	
Data hold time	$t_{PDH}$	10	-	-	
DOTCLK,VSYNC,HSYNC clock rise/fall time	$t_{rgrb}$ $t_{rgbf}$	-	-	5	

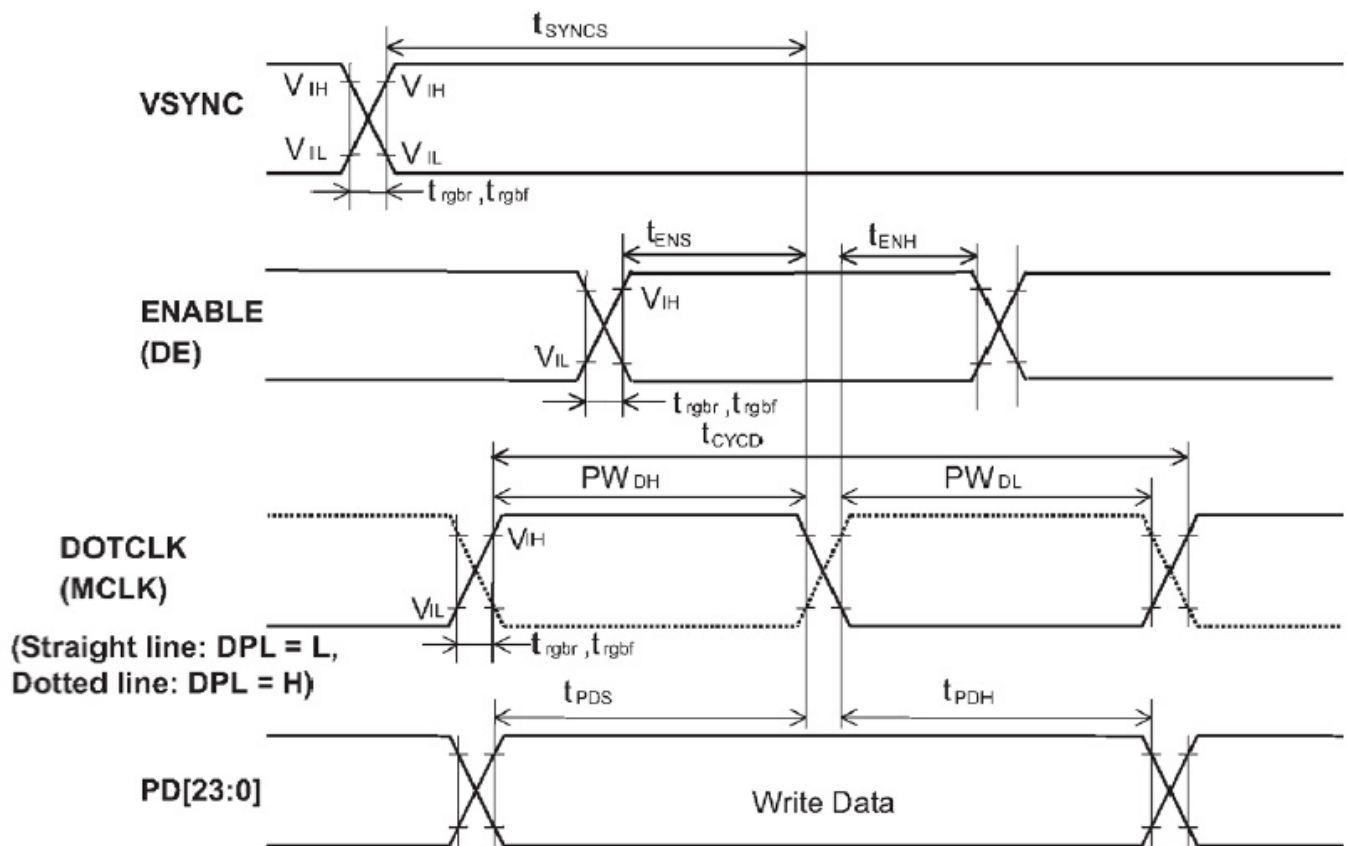

### 6.4 PON timing characteristics

※ Operating at VDD=2.25~3.5V , Ta = -40°C~+85°C

Item	Symbol	Min.	Typ.	Max.	unit
PON setup (SYNC mode)	$t_{PONS\bar{V}}$	10	-	-	DOTCLK

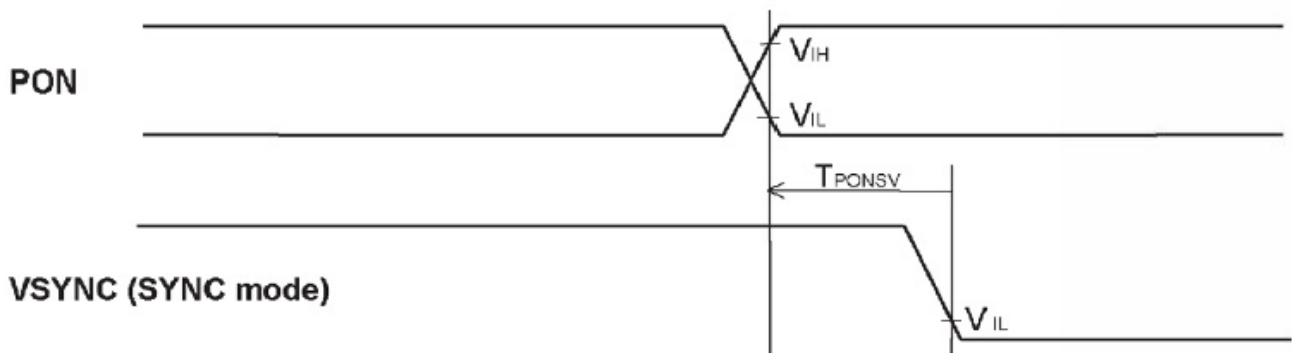

## 7. Power On/Off Sequence

- To prevent a latch-up or DC operation of the LCD module, the power on/off sequence should be as the diagram below.

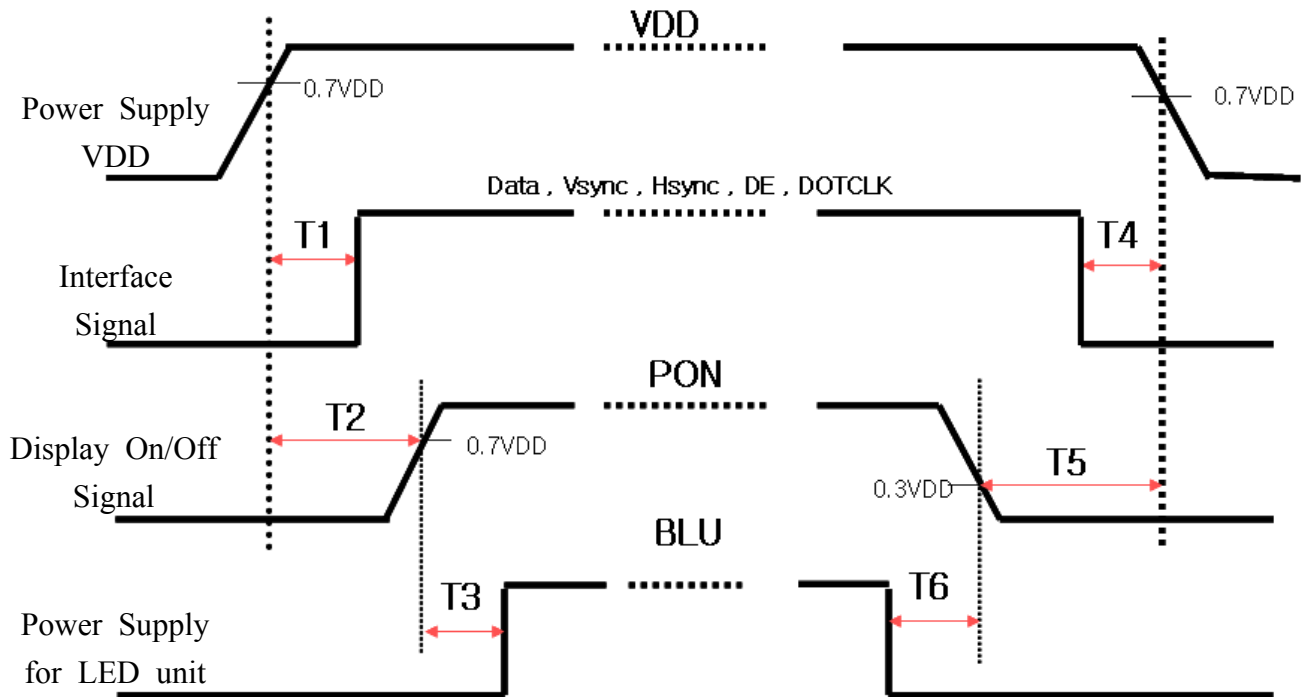

Symbol	Specification	Note
T1	$0 \text{ ms} < T1 < T2$	
T2	$10 \text{ ms} < T2$	(1)
T3	$10 \text{ frames} < T3$	
T4	$10 \text{ ms} < T4 < T5$	
T5	$(5 \text{ frames} + T4) < T5$	(1)
T6	$10 \text{ frames} < T6$	

Note(1) Refer to "6-4. PON timing characteristics."

APPROVAL

### 8. Outline Dimension

NO	PART NAME	CODE NO	SPECIFICATION	Q'TY	SPEC NO	REMARK
1	OUTLINE DIMENSION	-	LMS430HF05	1EA		

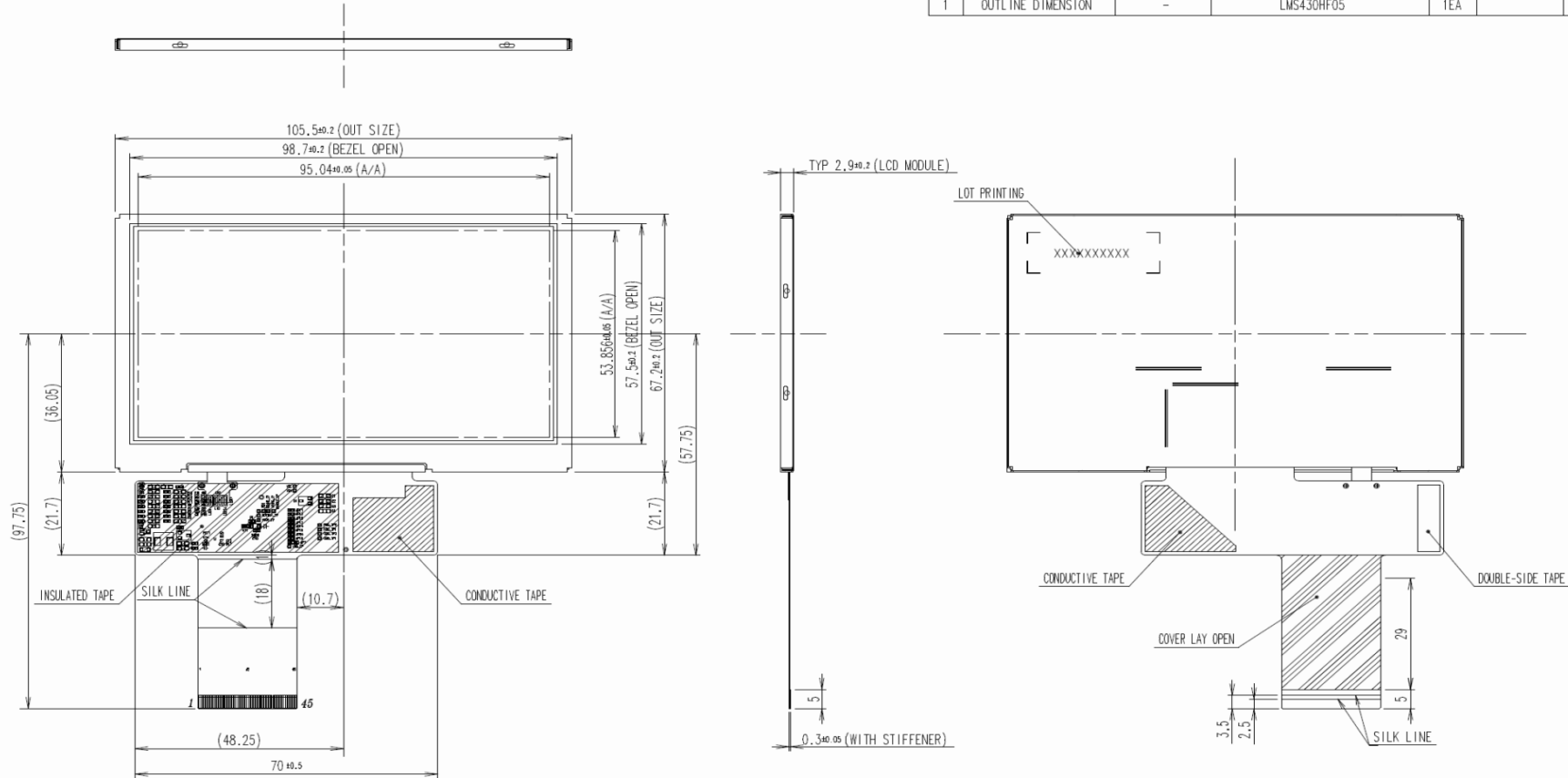

NO-9-9-VER	GENERAL TOLERANCE				REV	DATE	DESCRIPTION OF REVISION				REASON		CHG'D BY
	STEP	LEVEL 1	LEVEL 2	LEVEL 3	UNIT	mm	DRA'N BY	DES'D BY	CHK'D BY	APP'D BY	MODEL NAME	LMS430HF05	
	0 < X ≤ 4	±0.05	±0.1	±0.2	SCALE	1 / 1	S.M.KIM				Y.B.CHU	PART/SHEET NAME	OUTLINE DIMENSION
	4 < X ≤ 16	±0.08	±0.15	±0.3	TOLERANCE	LEVEL 3	07.07.27				07.07.27	SHEET	1 / 1
	16 < X ≤ 64	±0.12	±0.25	±0.5	SAMSUNG ELECTRONICS				SPEC. NO	CODE NO.	VER.	000	
64 < X ≤ 256	±0.25	±0.4	±0.8										



## 9. Packing

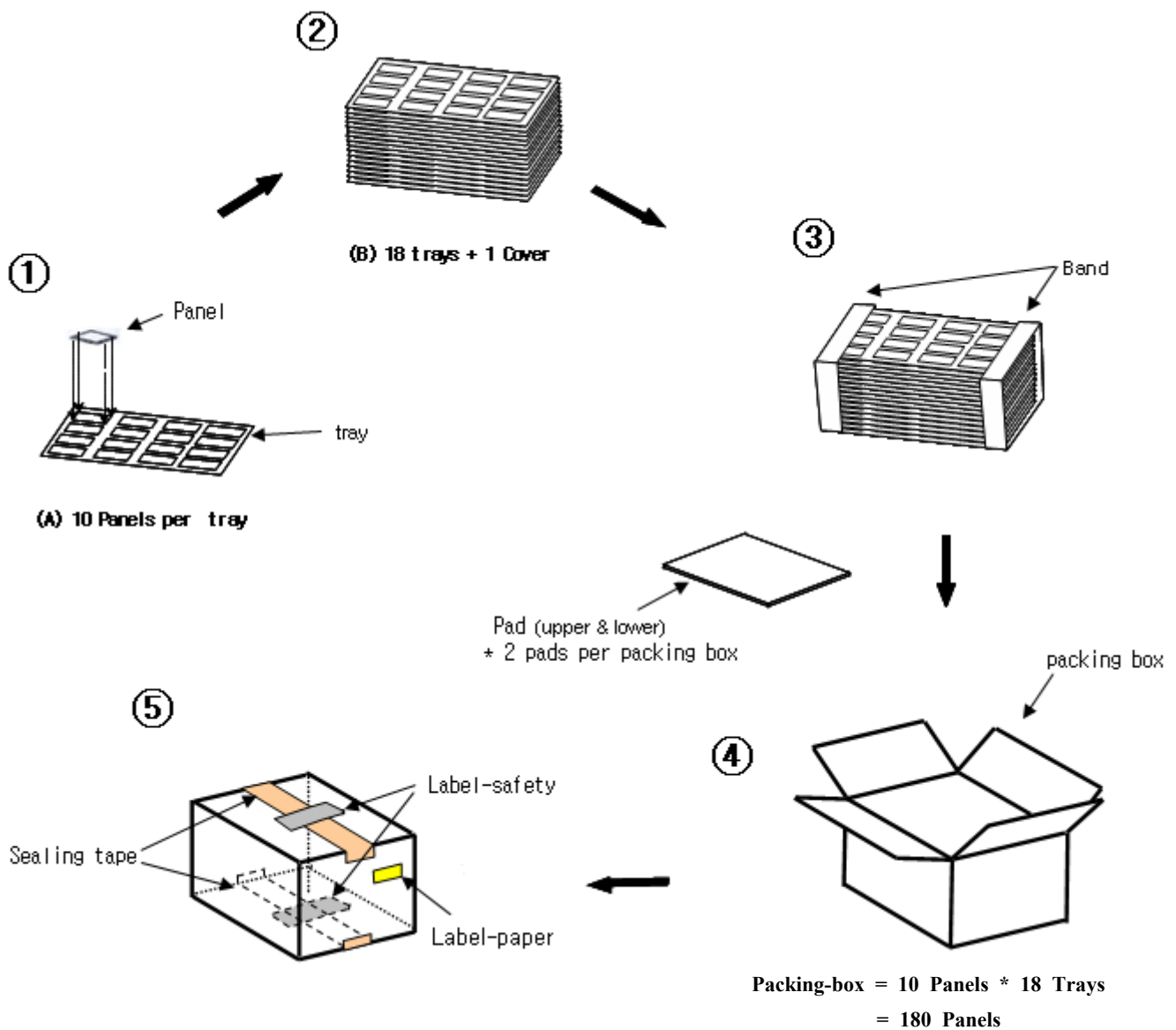

### Note

- (1) Total : Box: Approx. : 11.6 Kg
- (2) Size : Box: 505(W) x 355(D) x 200(H)
- (3) Place the panels in the tray facing the direction shown in the figure.
- (4) Place 18 tray and cover(empty tray) and pads inside the packing-box.
- (5) Seal the packing-box. Affix the label-safety.

## 10. Marking & Others

A nameplate bearing followed by is affixed to a shipped product at the Specified location on each product.

(1) Packing case attach

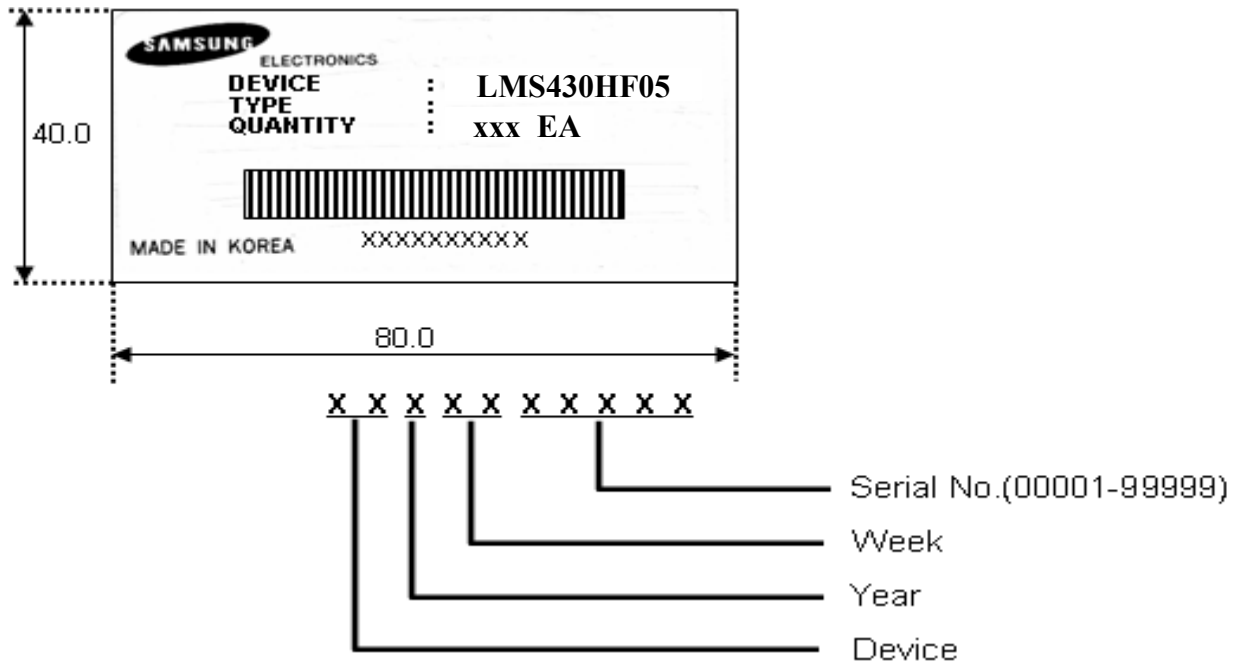

## 11. General Precautions

### 11.1 Handling

- (a) When the module is assembled, it should be attached to the system firmly. Be careful not to twist and bend the module.
- (b) Refrain from strong mechanical shock and / or any force to the module. In addition to damage, this may cause improper operation or damage to the module and back-light unit.
- (c) Note that polarizers are very fragile and could be easily damaged. Do not press or scratch the surface harder than a HB pencil lead.
- (d) Wipe off water droplets or oil immediately. If you leave the droplets for a long time, Staining and discoloration may occur.
- (e) If the surface of the polarizer is dirty, clean it using some absorbent cotton or soft cloth.
- (f) The desirable cleaners are water, IPA(Isopropyl Alcohol) or Hexane. Do not use Ketone type materials(ex. Acetone), Ethyl alcohol, Toluene, Ethyl acid or Methyl chloride. It might permanent damage to the polarizer due to chemical reaction.
- (g) If the liquid crystal material leaks from the panel, it should be kept away from the eyes or mouth. In case of contact with hands, legs or clothes, it must be washed away thoroughly with soap.
- (h) Protect the module from static , it may cause damage to the Integrated Gate Circuit.
- (i) Use finger-stalls with soft gloves in order to keep display clean during the incoming inspection and assembly process.
- (j) Do not disassemble the module.
- (k) Do not adjust the variable resistor which is located on the back side.
- (l) Protection film for polarizer on the module shall be slowly peeled off just before use so that the electrostatic charge can be minimized.
- (m) Pins of I/F connector shall not be touched directly with bare hands

**11.2 Storage**

- (a) Do not leave the panel in high temperature, and high humidity for a long time. It is highly recommended to store the module with temperature from 0 to 35°C and relative humidity of less than 70%.
- (b) Do not store the TFT-LCD module in direct sunlight.
- (c) The module shall be stored in a dark place. It is prohibited to apply sunlight or fluorescent light during the store.

**11.3 Operation**

- (a) Do not connect, disconnect the module in the "Power On" condition.
- (b) Power supply should always be turned on/off by the "Power on/off sequence"
- (c) Module has high frequency circuits. Sufficient suppression to the electromagnetic interference shall be done by system manufacturers. Grounding and shielding methods may be important to minimize the interference.

**11.4 Others**

- (a) The Liquid crystal is deteriorated by ultraviolet, do not leave it in direct sunlight and strong ultraviolet ray for many hours.
- (b) Avoid condensation of water. It may result in improper operation or disconnection of electrode.
- (c) Do not exceed the absolute maximum rating value. ( the supply voltage variation, input voltage variation, variation in part contents and environmental temperature, and so on) Otherwise the panel may be damaged.
- (d) If the panel displays the same pattern continuously for a long period of time, it can be the situation when the image "Sticks" to the screen.
- (e) This panel has its circuitry FPC on the bottom side and should be handled carefully in order not to be stressed.
- (f) Avoid shortness between LED soldering pad and TSP soldering pad.

## 12. Reliability Test Result

Item	Condition	Sample Size	Test Result	Remark
High Temperature Operating Life test	70°C 160HR	10EA	PASS	Panel Surface
Low Temperature Operating Life test	-20°C 160HR	5EA	PASS	
Thermal Humidity Bias	60°C 90%RH 160HR	10EA	PASS	Panel Surface
On/Off Test	70°C ⇔ -30°C (5CYC),	10EA	PASS	Note(1)
High Temperature Storage test	85°C 160HR	5EA	PASS	Panel Surface
Low Temperature Storage test	-40°C 160HR	5EA	PASS	
Wet Humidity Temperature Storage test	60°C/90%RH 160HR	10EA	PASS	
Thermal Cycle storage test	-40~85°C, 30CYC	10EA	PASS	Note(2)
Electrical Static Discharge	Contact:±4kV, 150pF/330Ω Non-contact:±8kV, 150pF/330Ω	5EA 5EA	PASS	Note(3)
Box Vibration	Random Vibration MIN-STD 810E, up/down(Z)Axis	(1BOX Small)	PASS	Note(4)
Box Drop	1 corner, 3 edges, 6 surfaces under 9.1kg:76cm, 9.2~18.2kg: 66cm	(1BOX Medium)	PASS	

Note(1) ON Time over 10 seconds, OFF Time under 10 seconds.

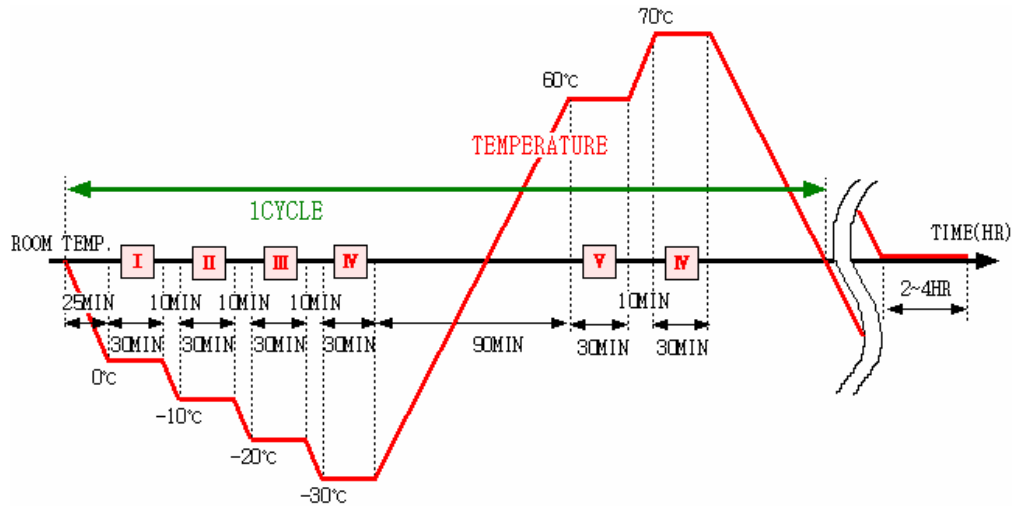

Note(2) STORAGE

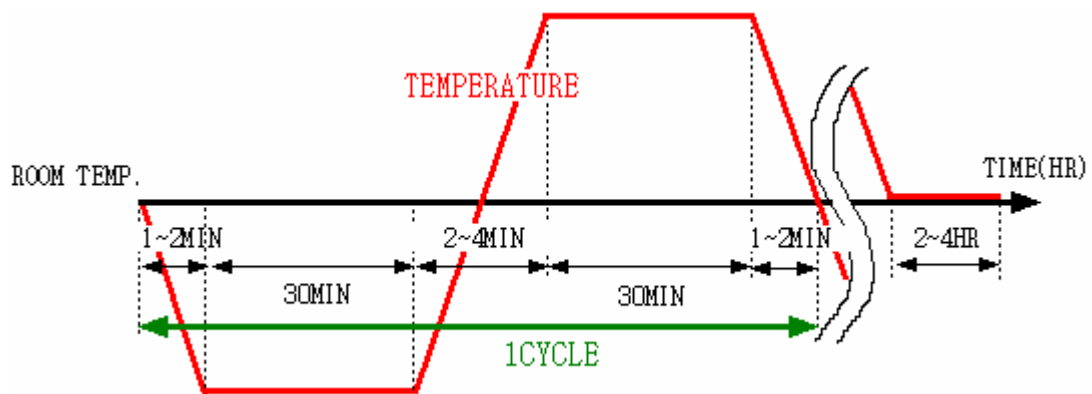

Note(3) Main-LCD, 5 times to every 4 corners of active area.

Note(4) Basic transportation by common carrier environmental, 514.4 MIL-STD-810E.

OVERALL RMS LEVEL	BREAK POINT					
	FREQUENCY	PSD VALUE	FREQUENCY	PSD VALUE	FREQUENCY	PSD VALUE
0.74G	10Hz	0.00650	121Hz	0.00300	340Hz	0.00003
	20Hz	0.00650	200Hz	0.00300	500Hz	0.00015
	120Hz	0.00020	240Hz	0.00150	-	-