

Reference Only

Preliminary

www.DataSheet4U.com

Product Information

MODEL NO. : LMS800SF01
(General형)

Issued date : JAN. 08. 2008

Note : This product information is subject to change without notice.

Mobile LCD Development Team
Samsung Electronics Co . , LTD.



Contents

Revision History	-----	(3)
General Description	-----	(4)
1. Absolute Maximum Ratings	-----	(5)
1.1 Absolute Ratings Of Environment		
1.2 Electrical Absolute Ratings		
2. Optical Characteristics	-----	(7)
3. Electrical Characteristics	-----	(11)
3.1 TFT-LCD Module		
3.2 Back-light Unit		
3.3 Power on/off sequence		
4. Block Diagram	-----	(15)
4.1 TFT-LCD Module		
4.2 Back Light Unit		
5. Input Terminal Pin Assignment	-----	(16)
5.1 Input Signal & Power		
5.2 Back light unit		
5.3 Input Signals, Basic Display Colors and Gray Scale of Each Color		
5.4 Pixel format		
5.5 Display scan direction		
6. Interface Timing	-----	(22)
6.1 Timing Parameters		
6.2 Timing diagram of interface signals		
6.3 Power ON/OFF Sequence		
7. Mechanical Outline Dimension	-----	(26)
8. Packing	-----	(27)
9. Marking & Others	-----	(28)
10.1 Packing case attach		
10.2 Module attach		
10. General Precaution	-----	(29)
10.1 Handling		
10.2 Storage		
10.3 Operation		
10.4 Others		



Revision History

Date	Ver No	Page	Summary
Jau. 08. 2008	000		Ver 000 was issued.



General Description

www.DataSheet4U.com

*** Description**

LMS800SF01 is a color active matrix TFT (Thin Film Transistor) liquid crystal display (LCD) that uses amorphous silicon TFT as a switching devices. This model is composed of a TFT LCD panel, a driver circuit and a back-light system. The resolution of a 8.0 SVGA contains 800 x 600 pixels and can display up to 262,144colors.

*** Features**

- High Brightness
- Wide viewing angle
- High Speed response time
- High contrast ratio
- SVGA(800x600pixels) resolution
- Low power consumption
- TTL Interface

*** Applications**

- Display terminals for Digital Photo frame application products
- Amusement application products
- Monitors for Industrial machine
- Please contact SEC When using on not specified applications

*** General information**

Items	Specification	Unit	Note
Display area	162.0(H) x 121.5(V)	mm	-
Driver element	a-Si TFT active matrix	-	-
Display colors	262.144	colors	-
Number of pixels	800(H) x 600(V) (SVGA)	dot	-
Pixel arrangement	RGB stripe	-	-
Dot pitch	0.2025(H) x 0.2025(V) (Typ)	mm	-
Display mode	Normally White	-	-
Gray inversion direction	6	o'clock	-

*** Mechanical information**

Item	Min.	Typ.	Max.	Unit	Note
Module size	Horizontal(H)	(183)		mm	-
	Vertical(V)	(141)		mm	-
	Depth(D)	(6.3)		mm	-
Weight		TBD		g	-



1. Absolute Maximum Ratings

www.DataSheet4U.com

1.1 Absolute Ratings of Environment

Item	Symbol	Min.	Max.	Unit	Note
Storage temperature	T _{STG}	(-20)	(60)	°C	(1)
Operating temperature	T _{OPR}	(-10)	(50)	°C	(1)
Shock (non-operating)	S _{NOP}	-	100	G	(2),(4)
Vibration (non-operating)	V _{NOP}	-	1.5	G	(3),(4)

Note (1) Temperature and relative humidity range are shown in the figure below.

90% RH Max.

Maximum wet - bulb temperature at 39°C or less. (No condensation.)

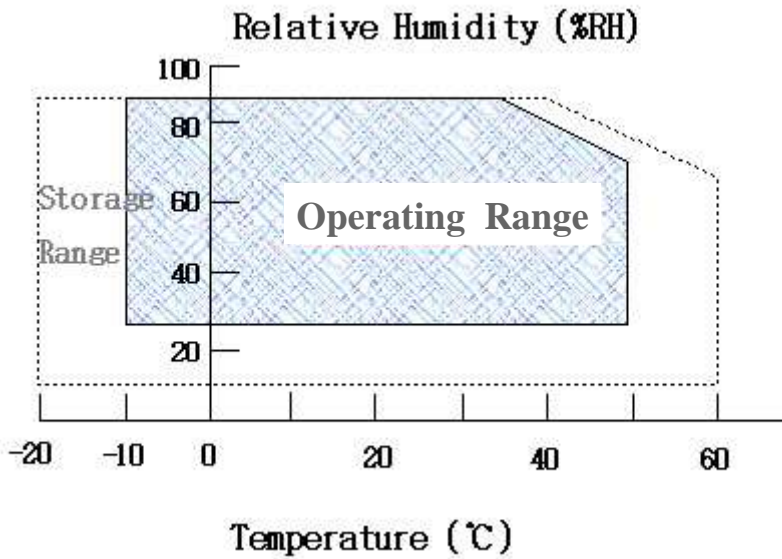

- (2) 6ms, (half) sine wave, one time for ±X, ±Y, ±Z.
- (3) (10) - (500) Hz, Sweep rate (1)hr, (3)hr for X,Y,Z.
- (4) At testing Vibration and Shock, the fixture in holding the Module to be tested have to be hard and rigid enough so that the Module would not be twisted or bent by the fixture.



1.2 Electrical Absolute Maximum Ratings

(1) TFT-LCD Module

(Ta=25°C, Vss=GND=0V)

Item	Symbol	Min	Max	Unit	Note
Power supply (Source IC)	VCC	-0.5	5.0	V	
Power supply (Source IC)	AVDD	-0.5	13.5	V	
Power supply (Gate IC)	VGH	-0.3	42.0	V	
Power supply (Gate IC)	VDD	-0.3	7.0	V	
Power supply (Gate IC)	VEE	VGH-42	0.3	V	
Input voltage (Source IC)	VIs	-0.5	VCC+0.5	V	(1)
Input voltage (Source IC)	V γ	-0.3	AVDD+0.3	V	(2)
Input voltage (Gate IC)	V γ	-0.3	VDD+0.3	V	(3)
Common electrode driving signal	VCOM	(4.0)	(5.0)	V	(4)
Operating temperature	Topr	(-10)	(50)	°C	(5)
Storage temperature	Tstg	(-20)	(60)	°C	

*Note

(1) R0~R5, G0~G5, B0~B5, CLK, DIO1, DIO2, LD, POL, REV, SHL

(2) V1, V2, V3, V4, V6, V7, V8, V9, V10, V11, V12, V13, V14

(3) OE, L/R, CPV, STV1, STV2

(4) The operating temperature only guarantees operation of the circuit.

In case of below 0°C, the response time of liquid crystal (LC) becomes slower and the color of panel becomes darker than normal one. Level of retardation depends on temperature, because of LC's characteristics. If product is exposed to high temperatures for extended time, there is a possibility of the polarizer film damage which could degrade the optical characteristics

(2) Back-Light Unit

(Ta = 25 ± 2°C)

Item	Symbol	Min.	Max.	Unit.	Note
Lamp Current	I _L	TBD	TBD	mA	(1)
Lamp frequency	F _L	TBD	TBD	khz	(1)

Note (1) Permanent damage to the device may occur if maximum values are exceeded or reverse voltage is loaded.

Functional operation should be restricted to the conditions described under normal operating conditions.



2. Optical Characteristics

www.DataSheet4U.com

The following items are measured under stable conditions. The optical characteristics should be measured in a dark room or equivalent state with the methods shown in Note

(1). Measuring equipment: SR-3, BM-7, EZ-Contrast

(Ta = 25 ± 2°C, Vcc = 3.3V, fv = 60Hz, IL = 7mA)

Item	Symbol	Condition	Min.	Typ.	Max.	Unit	Note	
Contrast ratio (Center point)	C/R	NOTE (1)	-	(800)	-	-	(2) SR-3	
Luminance of white (Center point)	YL		-	(250)	-	cd/m ²	(3) SR-3	
Response time	Rising:Tr Falling:Tf		Tr+Tf	-	(16)	-	msec	(4) BM-7
Color chromaticity (CIE 1931)	White	Wx	-	(0.310)	-	-	(5) SR-3	
		Wy	-	(0.340)	-			
	Red	Rx	Normal Viewing Angle	-	(0.610)			-
		Ry	B/L On	-	(0.350)			-
	Green	Gx		-	(0.305)			-
		Gy		-	(0.550)			-
	Blue	Bx		-	(0.150)			-
		By	-	(0.135)	-			
Viewing angle	Hor.	θL	-	(80)	-	Degrees	(6) Ez-Contrast	
		θR	-	(80)	-			
	Ver.	ΦH	B/L On	-	(80)			-
		ΦL	-	-	(80)			-
5 Points White variation	δL		-	1.25	1.45		(7) SR-3	



Note (1) Test Equipment Setup

www.DataSheet4U.com

After stabilizing and leaving the panel alone at a given temperature for 30 min , the measurement should be executed. Measurement should be executed in a stable, windless, and dark room. 30 min after lighting the back-light. This should be measured in the center of screen.

Environment condition : $T_a = 25 \pm 2 \text{ }^\circ\text{C}$

Back-Light On condition

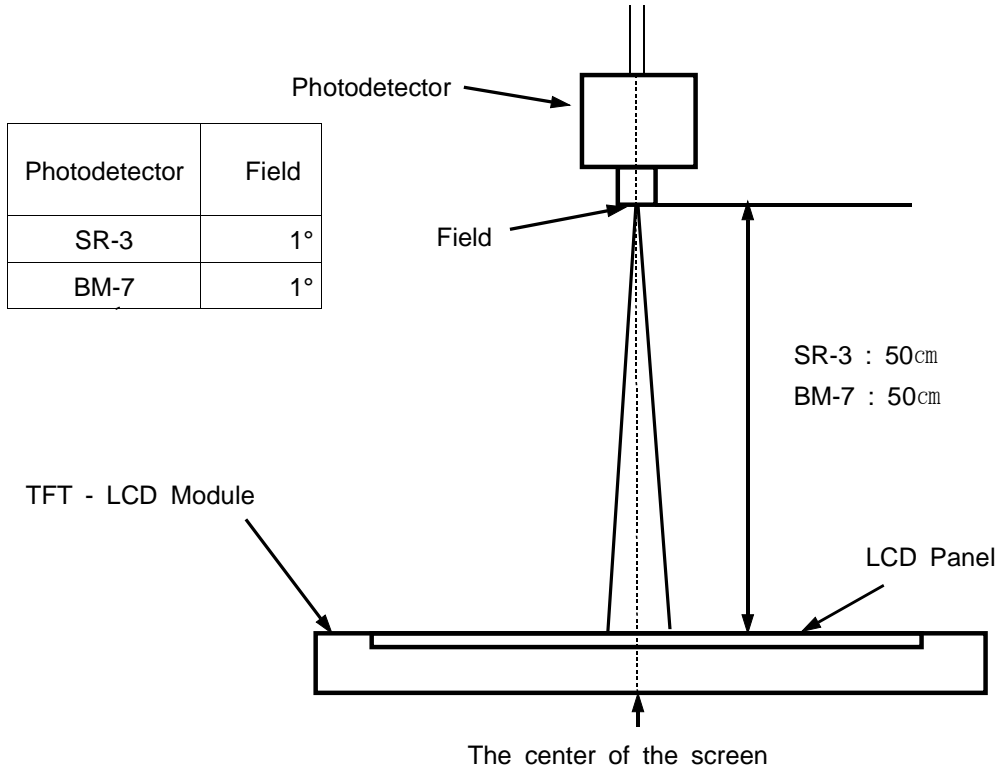

Note (2) Definition of Contrast Ratio (C/R) : Ratio of gray max (Gmax) & gray min (Gmin) at the center point

$$CR = \frac{G_{max}}{G_{min}}$$

* Gmax : Luminance with all pixels white

* Gmin : Luminance with all pixels black

Note (3) Definition of Luminance of White : Luminance of white at the center point

Note (4) Definition of Response time : Sum of Tr ,Tf

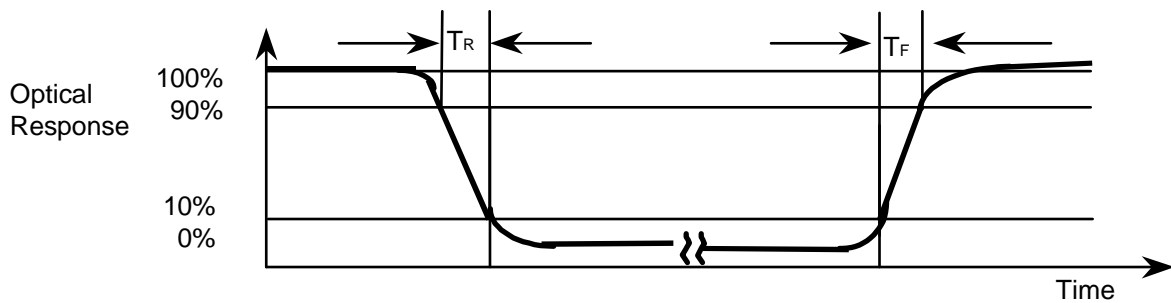
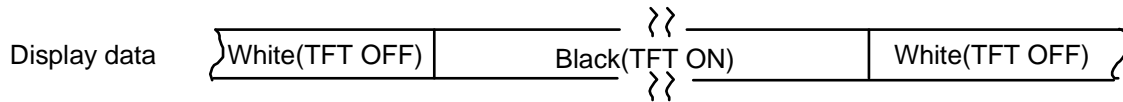

Note (5) Definition of Color Chromaticity (CIE 1931)

Color coordinate of white & red, green, blue at center point.



www.DataSheet4U.com

Note (6) Definition of Viewing Angle : Viewing angle range (CR ≥ 10)

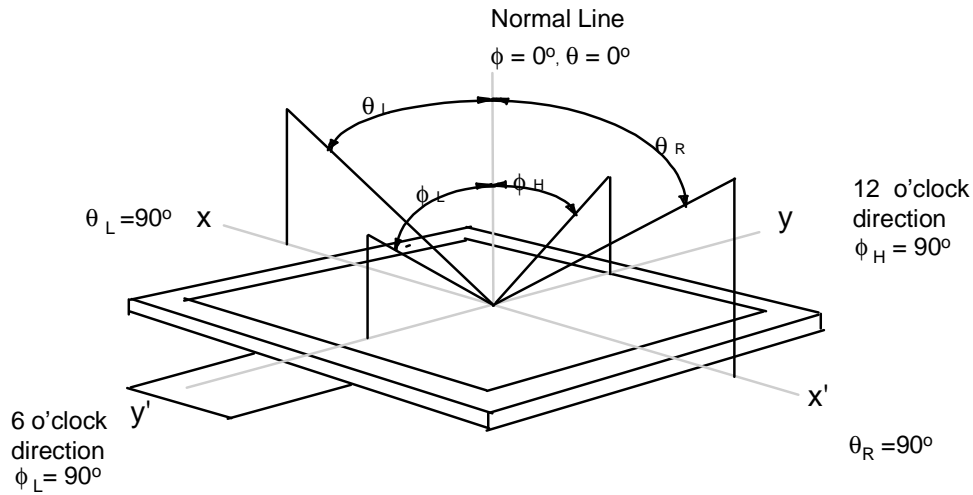

Note (7) Definition of 5 points white variation (δL) [① ~ ⑤]

$$\delta L = \frac{\text{Maximum luminance of 5 points}}{\text{Minimum luminance of 5 points}}$$

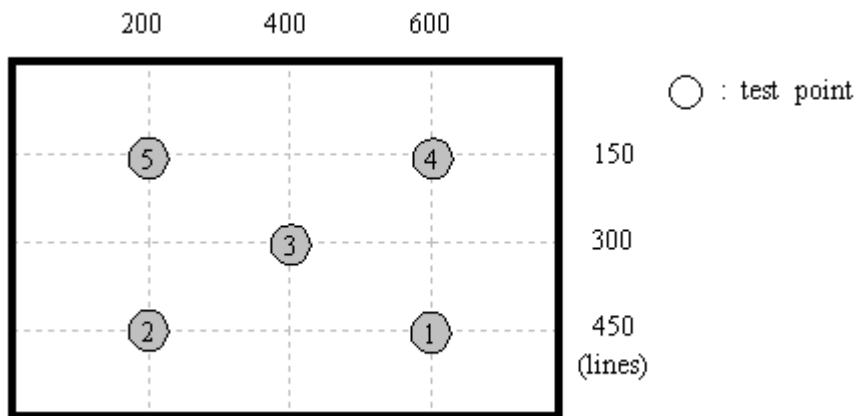

3. Electrical Characteristics

www.DataSheet4U.com

3.1 TFT-LCD Module

Ta = 25 ± 2°C

Item		Symbol	MIN	TYP	MAX	Unit	Remark
Source power supply	Digital	VCC	2.7	3.3	3.6	V	
		Ivcc	-	TBD	TBD	mA	
	Analog	AVDD	6.5	(10)	13.5	V	
		Iavdd	TBD	TBD	TBD	mA	
Gate power supply	Gate On	VGH	7	(20)	VGL+40	V	
	Gate Off	VGL	-20	(-10)	-5	V	
	Input	VDD	2.3	3.3	5.5	V	
		Ivls	-	TBD	TBD	uA	
Input voltage (Source)	Low	VIsl	GND	-	0.3VCC	V	(1)
	High	Vlsh	0.7VCC	-	VCC	V	(1)
Input voltage (Gate)	Low	Vlgl	GND	-	0.3VDD	V	(2)
	High	Vlgh	0.7VDD	-	VDD	V	(2)
Reference voltage		Vlgamma	0	-	AVDD	V	(3)
Common Electrode Driving Signal							

* Note

(1) R0~R5, G0~G5, B0~B5, CLK, DIO1, DIO2, LD, POL, REV, SHL

(2) OE, L/R, CPV, STV1, STV2

(3) V1, V2, V3, V4, V6, V7, V8, V9, V10, V11, V12, V13, V14



www.DataSheet4U.com

(4) Power dissipation check pattern

*a) White Pattern

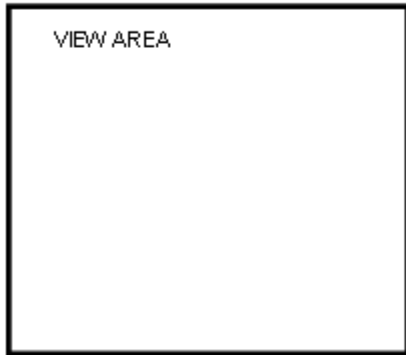

*b) Mosaic Pattern

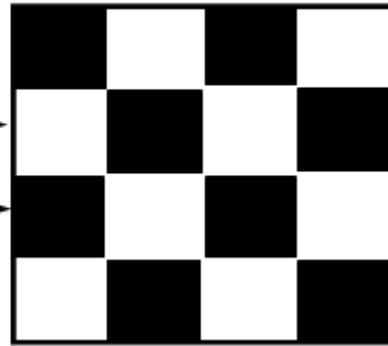

Display Brightest Gray Level →

Display Darkest Gray Level →

*c) Black pattern



3.2 Back-Light unit

Item	Symbol	MIN	TYP	MAX	Unit	Note
Lamp current	IL	TBD	7.0	TBD	mArms	(1)
Lamp voltage	VL	-	TBD	-	Vrms	(2)
Power consumption	PL	-	TBD	-	W	
Lamp frequency	FR	TBD	TBD	TBD	KHz	(3)
Lamp startup voltage	VS		-	TBD	Vrms	Ta = +25°C
			-	TBD	Vrms	Ta = +0°C
Lamp life time	-	TBD	-		Hour	(4)

* Note

(1) Current range that lifetime and reliability can be guaranteed.

Lamp current is measured with high frequency current meter as shown below.

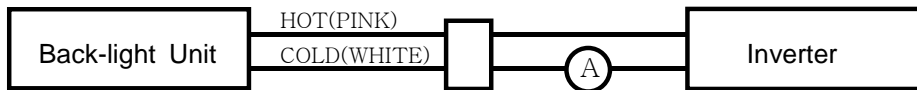

(2) The waveform of the inverter output voltage must be area symmetric.

(3) Lamp frequency may produce interference with horizontal synchronous frequency and may cause line flow on the display. Therefore lamp frequency should be detached from the horizontal synchronous frequency and its harmonics as far as possible in order to avoid interference.

(4) Lamp life time is defined as the time when the brightness of the Lamp not to become less than 50% of the original value in the continuous operation under the condition of lamp allowed current at the ambient temperature 25±5°C.



3.3 Power on/off sequence

www.DataSheet4U.com

To prevent a latch-up or DC operation of the LCD module, the power on/off sequence should be as the diagram below.

- Power On : VCC,VDD → VEE → AVDD → VGH

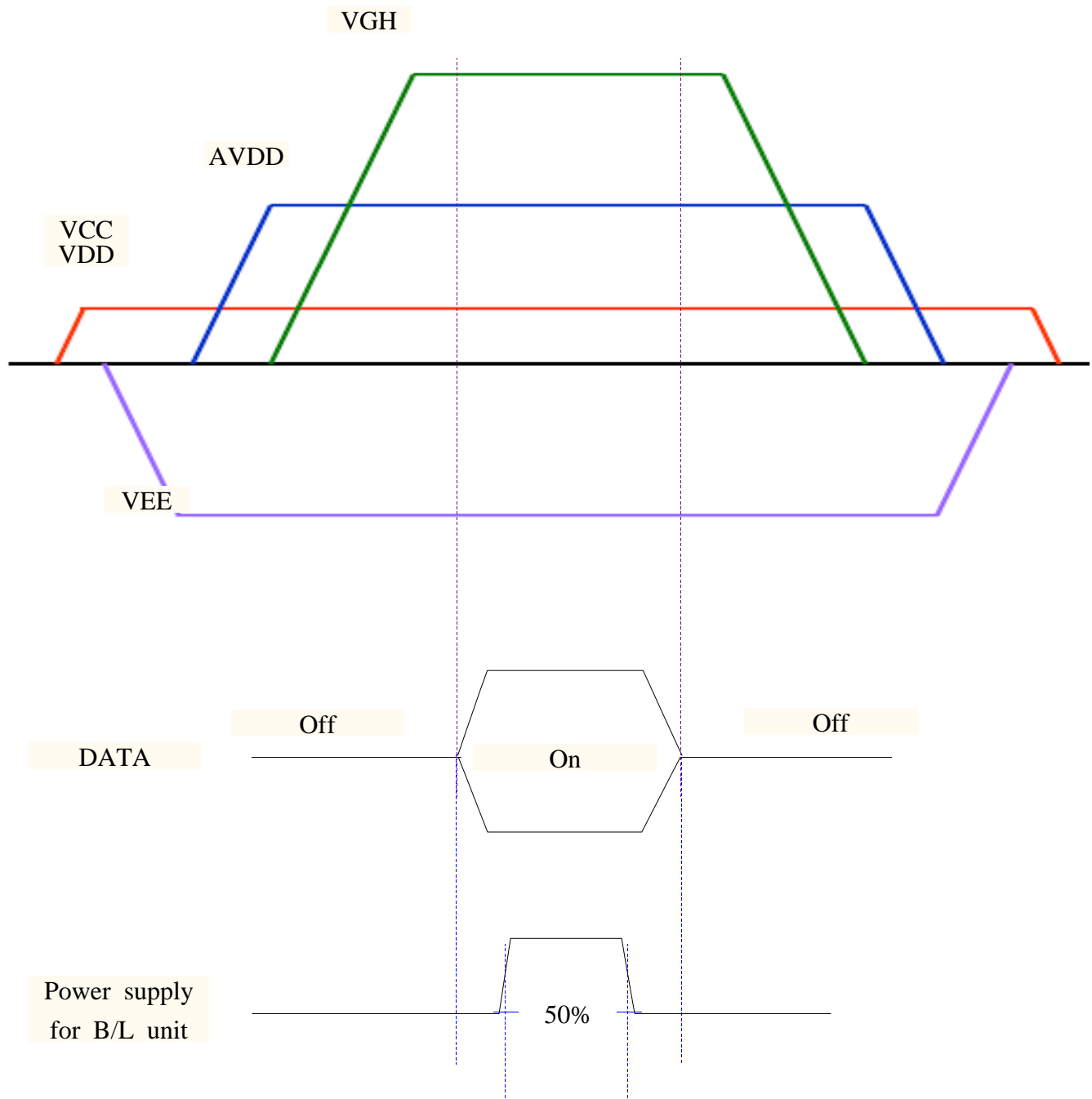

4. Block Diagram

www.DataSheet4U.com

4.1 TFT LCD Module

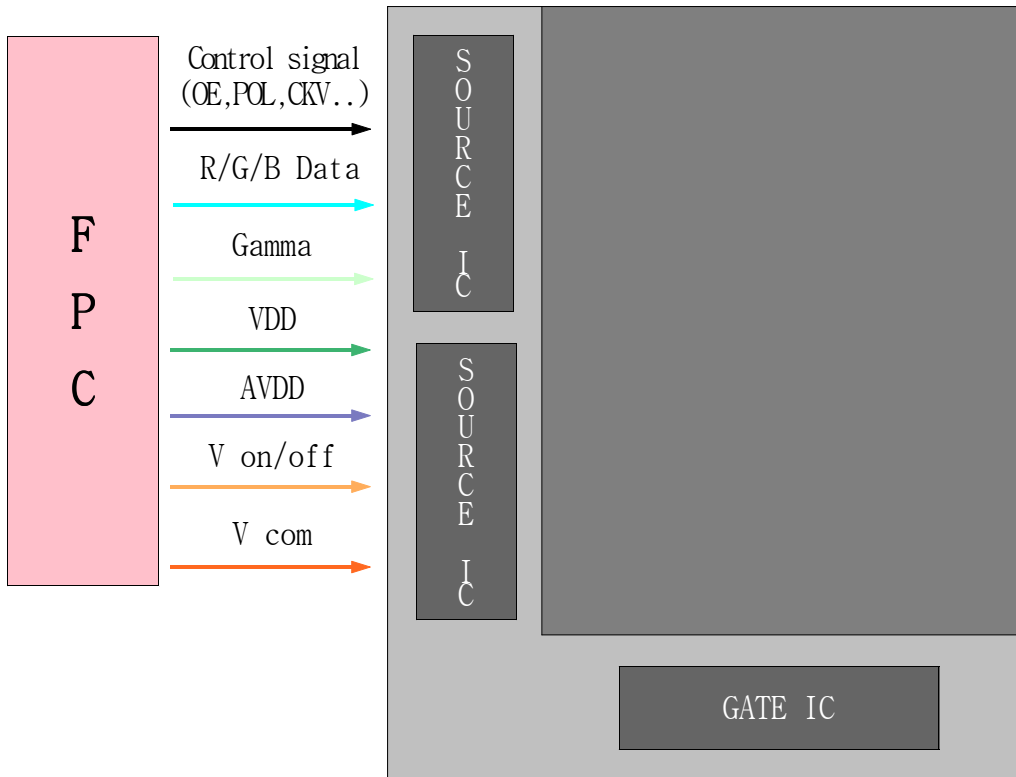

4.2 Back-light Unit

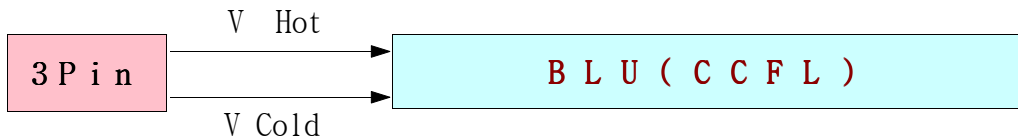

5. Input Terminal Pin Assignment

www.DataSheet4U.com

5.1 Input Signal & Power(TTL, Connector :)

Pin No	Symbol	Function	Remark
1	VCOM	VCOM	
2	N.C	No connection	
3	DIO1	Start pulse of source IC	
4	VCC	Power supply for digital (Source)	
5	SHL	Source IC output direction	
6	GND	Ground	
7	CLK	Source IC clock	
8	GND	Ground	
9	R0	Red data LSB	
10	R1	Red data	
11	R2	Red data (Note 6-2)	
12	R3	Red data (Note 6-2)	
13	R4	Red data (Note 6-2)	
14	R5	Red data MSB (Note 6-2)	
15	G0	Green data LSB (Note 6-2)	
16	G1	Green data (Note 6-2)	
17	G2	Green data (Note 6-2)	
18	G3	Green data (Note 6-2)	
19	G4	Green data (Note 6-2)	
20	G5	Green data MSB (Note 6-2)	
21	AVDD	Power supply for analog (Source)	
22	V1	Reference voltage (Note 6-3,4)	
23	V2	Reference voltage (Note 6-3,4)	
24	V3	Reference voltage (Note 6-3,4)	
25	V4	Reference voltage (Note 6-3,4)	
26	V5	Reference voltage (Note 6-3,4)	
27	V6	Reference voltage (Note 6-3,4)	
28	V7	Reference voltage (Note 6-3,4)	
29	V8	Reference voltage (Note 6-3,4)	
30	V9	Reference voltage (Note 6-3,4)	



www.DataSheet4U.com

Pin No	Symbol	Function	Remark
31	V10	Reference voltage (Note 6-3,4)	
32	V11	Reference voltage (Note 6-3,4)	
33	V12	Reference voltage (Note 6-3,4)	
34	V13	Reference voltage (Note 6-3,4)	
35	V14	Reference voltage (Note 6-3,4)	
36	B0	Blue data LSB (Note 6-2)	
37	B1	Blue data (Note 6-2)	
38	B2	Blue data (Note 6-2)	
39	B3	Blue data (Note 6-2)	
40	B4	Blue data (Note 6-2)	
41	B5	Blue data MSB (Note 6-2)	
42	LD	Data Transfer (Source IC)	
43	REV	Data inversion (Source IC,connect to GND)	
44	POL	Data polarity inversion (Note 6-3)	
45	GND	Ground	
46	DIO2	Start pulse of source IC (Note 6-1)	
47	VCOM	VCOM	
48	OE	Gate IC Enable controle pulse input	
49	L/R	Gate IC output direction (Note 6-1)	
50	CPV	Gate IC clock	
51	STV2	Start pulse of Gate IC (Note 6-1)	
52	STV1	Start pulse of Gate IC (Note 6-1)	
53	N.C	No connection	
54	VGH	Power supply for gate On(Gate IC)	
55	N.C	No connection	
56	VEE	Power supply for Gate Off (Gate IC)	
57	N.C	No connection	
58	VDD	Power supply for digital (Gate)	
59	N.C	No connection	
60	VCOM	VCOM	



5.2 Back light unit (Connector : TBD)

www.DataSheet4U.com

Pin No	Symbol	Color	Function
1	HOT	Pink	High voltage
2	NC		No connection
3	COLD	White	Low voltage



www.DataSheet4U.com

5.3 Input Signal, Basic Display Colors and Gray Scale of Each Colors

COLOR	DISPLAY	DATA SIGNAL																		GRAY SCALE LEVEL
		RED						GREEN						BLUE						
		R0	R1	R2	R3	R4	R5	G0	G1	G2	G3	G4	G5	B0	B1	B2	B3	B4	B5	
BASIC COLOR	BLACK	0	0	0	0	0	0	0	0	0	0	0	0	0	0	0	0	0	0	-
	BLUE	0	0	0	0	0	0	0	0	0	0	0	0	1	1	1	1	1	1	-
	GREEN	0	0	0	0	0	0	1	1	1	1	1	1	0	0	0	0	0	0	-
	CYAN	0	0	0	0	0	0	1	1	1	1	1	1	1	1	1	1	1	1	-
	RED	1	1	1	1	1	1	0	0	0	0	0	0	0	0	0	0	0	0	-
	MAGENTA	1	1	1	1	1	1	0	0	0	0	0	0	1	1	1	1	1	1	-
	YELLOW	1	1	1	1	1	1	1	1	1	1	1	1	0	0	0	0	0	0	-
	WHITE	1	1	1	1	1	1	1	1	1	1	1	1	1	1	1	1	1	1	-
GRAY SCALE OF RED	BLACK	0	0	0	0	0	0	0	0	0	0	0	0	0	0	0	0	0	0	R0
	DARK ↑	1	0	0	0	0	0	0	0	0	0	0	0	0	0	0	0	0	0	R1
		0	1	0	0	0	0	0	0	0	0	0	0	0	0	0	0	0	0	R2
		:	:	:	:	:	:	:	:	:	:	:	:	:	:	:	:	:	:	R3~R60
		:	:	:	:	:	:	:	:	:	:	:	:	:	:	:	:	:	:	
	LIGHT ↓	1	0	1	1	1	1	0	0	0	0	0	0	0	0	0	0	0	0	R61
		0	1	1	1	1	1	0	0	0	0	0	0	0	0	0	0	0	0	R62
	RED	1	1	1	1	1	1	0	0	0	0	0	0	0	0	0	0	0	0	R63
GRAY SCALE OF GREEN	BLACK	0	0	0	0	0	0	0	0	0	0	0	0	0	0	0	0	0	0	G0
	DARK ↑	0	0	0	0	0	0	1	0	0	0	0	0	0	0	0	0	0	0	G1
		0	0	0	0	0	0	0	1	0	0	0	0	0	0	0	0	0	0	G2
		:	:	:	:	:	:	:	:	:	:	:	:	:	:	:	:	:	:	G3~G60
		:	:	:	:	:	:	:	:	:	:	:	:	:	:	:	:	:	:	
	LIGHT ↓	0	0	0	0	0	0	1	0	1	1	1	1	0	0	0	0	0	0	G61
		0	0	0	0	0	0	0	1	1	1	1	1	0	0	0	0	0	0	G62
	GREEN	0	0	0	0	0	0	1	1	1	1	1	1	0	0	0	0	0	0	G63
GRAY SCALE OF BLUE	BLACK	0	0	0	0	0	0	0	0	0	0	0	0	0	0	0	0	0	0	B0
	DARK ↑	0	0	0	0	0	0	0	0	0	0	0	0	1	0	0	0	0	0	B1
		0	0	0	0	0	0	0	0	0	0	0	0	0	1	0	0	0	0	B2
		:	:	:	:	:	:	:	:	:	:	:	:	:	:	:	:	:	:	B3~B60
		:	:	:	:	:	:	:	:	:	:	:	:	:	:	:	:	:	:	
	LIGHT ↓	0	0	0	0	0	0	0	0	0	0	0	0	0	1	0	1	1	1	B61
		0	0	0	0	0	0	0	0	0	0	0	0	0	1	1	1	1	1	B62
	BLUE	0	0	0	0	0	0	0	0	0	0	0	0	1	1	1	1	1	1	B63

Note)

- (1) Definition of Gray : Rn : Red Gray, Gn : Green Gray, Bn : Blue Gray (n = Gray level)
- (2) Input Signal : 0 = Low level voltage, 1 = High level voltage



www.DataSheet4U.com
5.4 Pixel Format

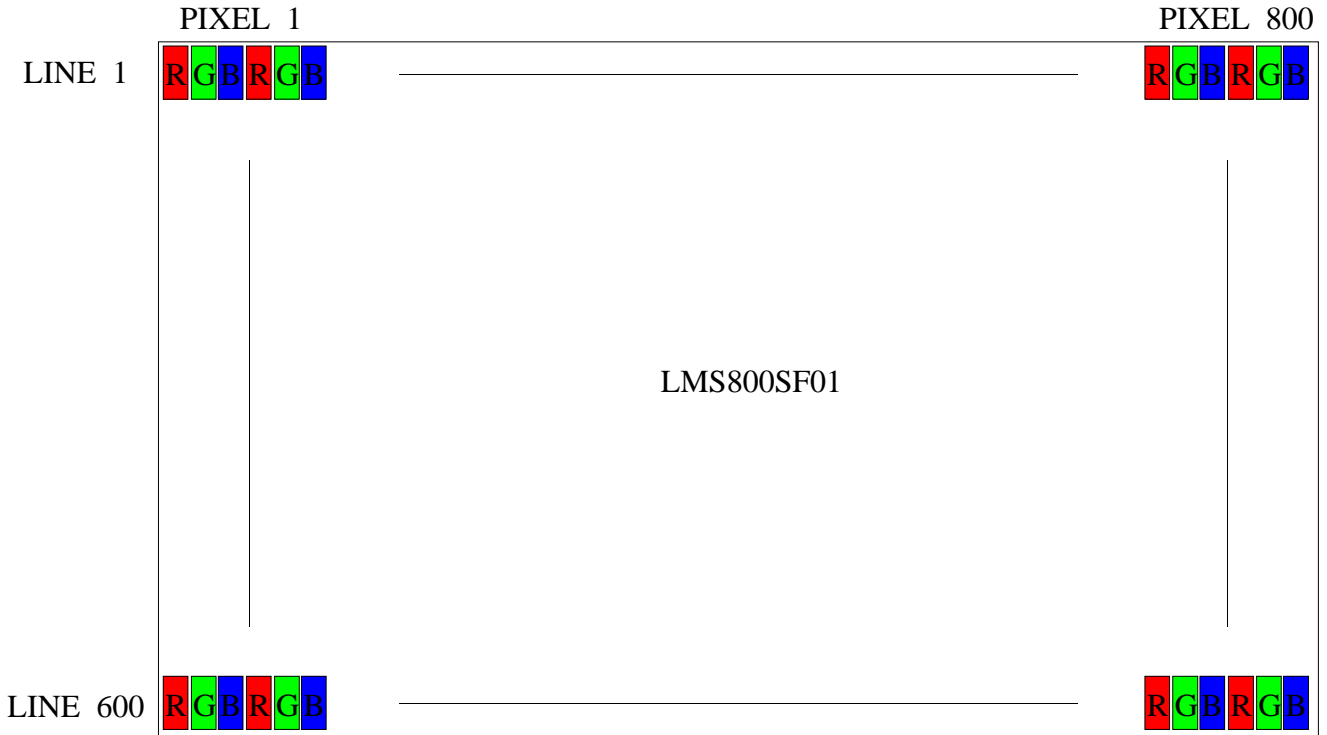

5.5 Display scan direction

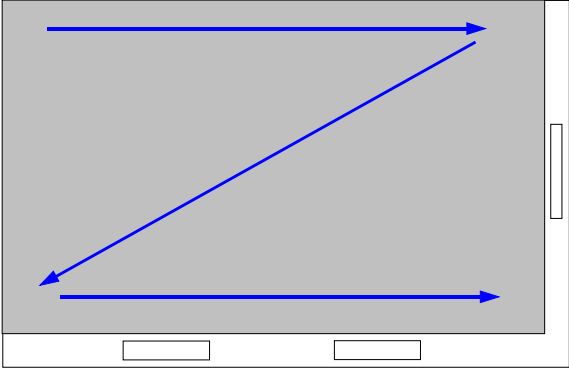
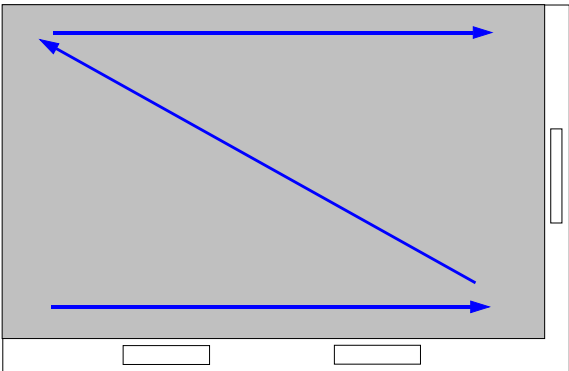
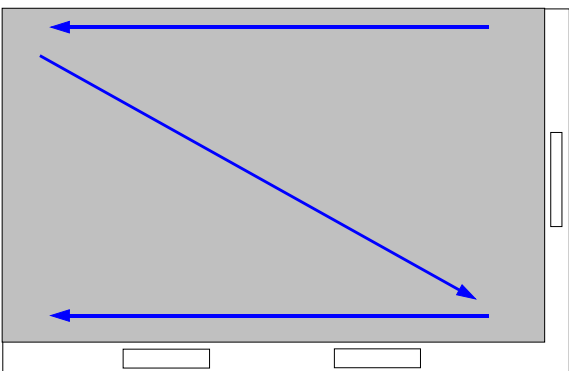
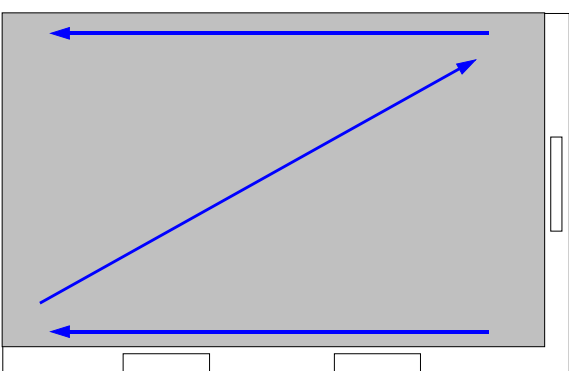
SHL	L/R	Display scan direction
H	L	 <p> ■ DIO11→S1→...→S1200→DIO12→DIO21→S1201→...→S2400→DIO22 ■ STV2→G600→...→G1→STV1 </p>
H	H	 <p> ■ DIO11→S1→...→S1200→DIO12→DIO21→S1201→...→S2400→DIO22 ■ STV1→G1→...→G600→STV2 </p>
L	L	 <p> ■ DIO22→S1200→...→S601→DIO21→DIO12→S600→...→S1→DIO11 ■ STV2→G600→...→G1→STV1 </p>
L	H	 <p> ■ DIO22→S1200→...→S601→DIO21→DIO12→S600→...→S1→DIO11 ■ STV1→G1→...→G600→STV2 </p>



6. Interface Timing

www.DataSheet4U.com

6.1 Timing Parameters

		Item	Symbol	MIN	TYP	MAX	Unit	Remark
S O U R C E	Clock	frequency	Fcph	-	33.2	41	MHz	
		period	Tcph		30.1	24.39	ns	
		high level width	Tcw	6	-	-	ns	
		low level width	Tcw	6	-	-	ns	
	Start pulse	frequency	Fdio	-	31.5	31.8	kHz	
		setup time	Tsudio	4	-	-	ns	
		hold time	Thdio	2	-	-	ns	
	Latch	start position	Tlds	5	-	-	Tcph	
		frequency	Fld	-	Fdio	-	kHz	
		latch position	Tld	1	-	-	Tcph	
	Data	pulse width of LD	Twld	2	-	-	Tcph	
		setup time	Tsuda	4	-	-	ns	
		hold time	Thda	2	-	-	ns	
	POL	frequency	Fpol	-	Fdio	-	kHz	
		setup time	Tsupol	6	-	-	ns	
hold time		Thpol	6	-	-	ns		
G A T E	Clock	frequency	Fcpv	-	Fdio	-	kHz	
		pulse width (Low)	Tcpvh	2.5	-	-	us	
		pulse width (High)	Tcpvl	2.5	-	-	us	
		pulse width	Tcpv	5	-	-	us	
	Start pulse	frequency		55	60	75	Hz	
		setup time	Tsustv	700	-	-	ns	
Blank Time	hold time	Thstv	700	-	-	ns		
	Vertical	Vbk	-	45	-	cpv		
	Horizontal	Hbk	-	254	-	clk		



T-CON USER INTERFACE INPUT SIGNAL FOR REFERENCE

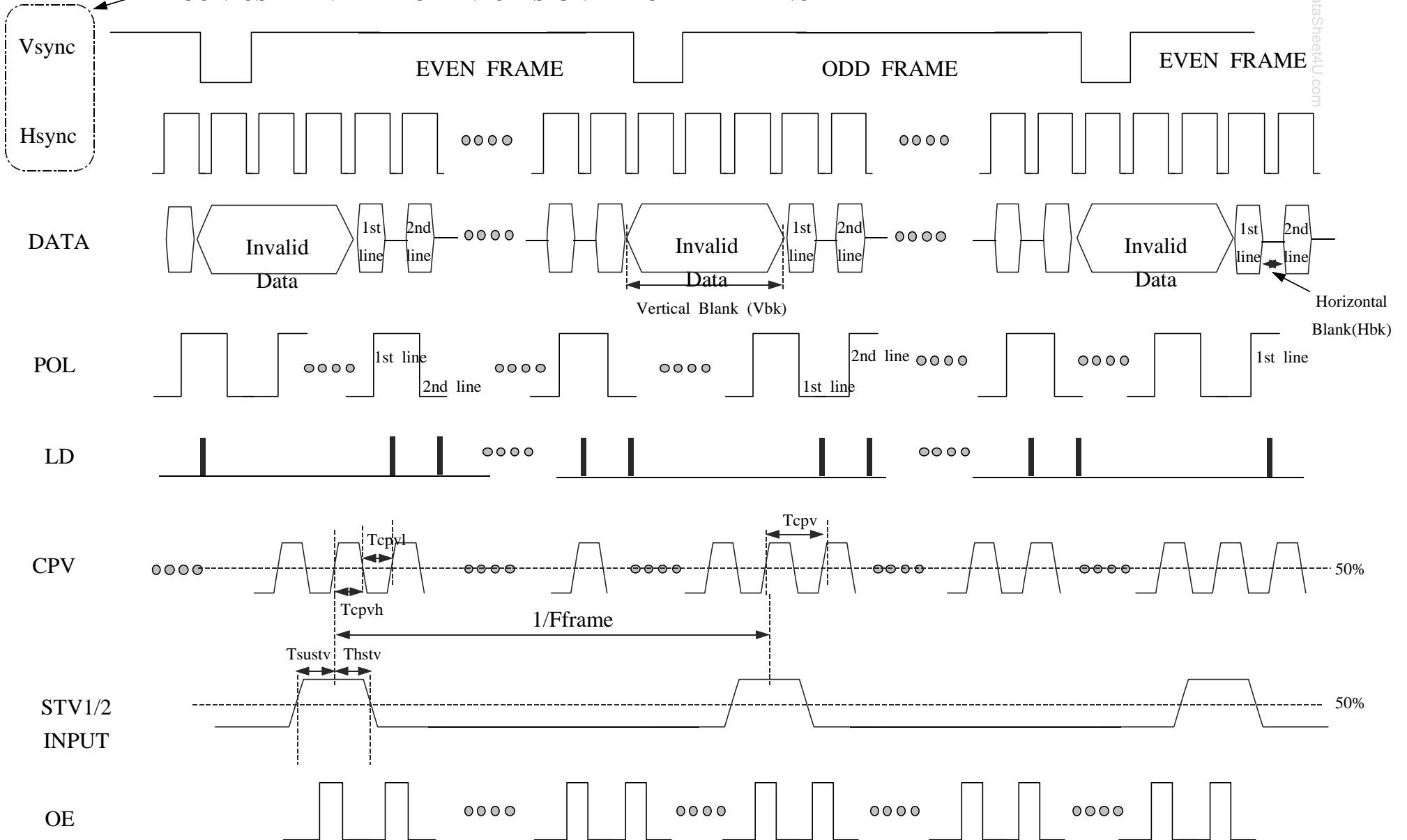

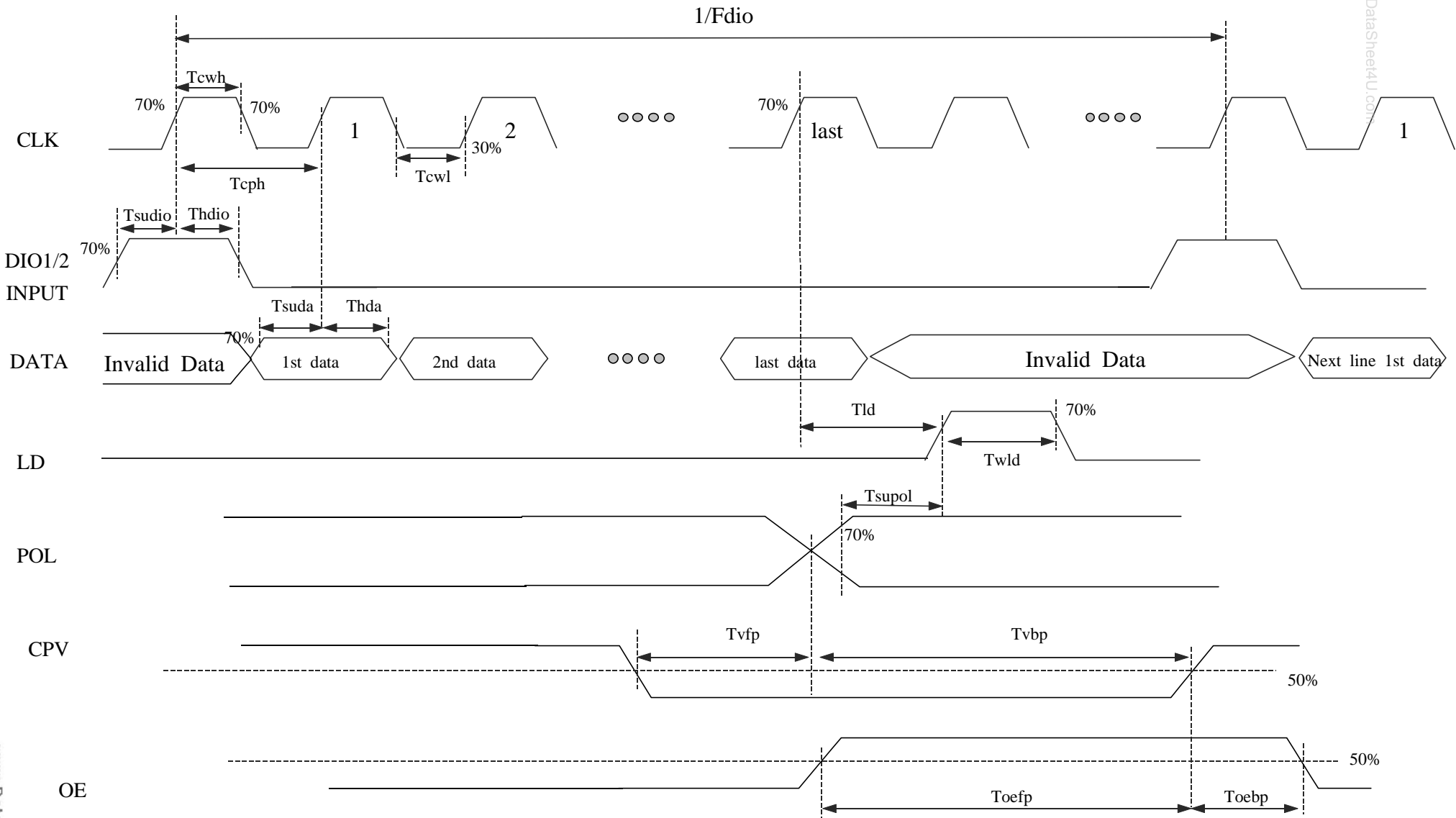

6.3 Power ON/OFF Sequence

To prevent a latch-up or DC operation of the LCD module, the power ON/OFF sequence should be as the diagram below.

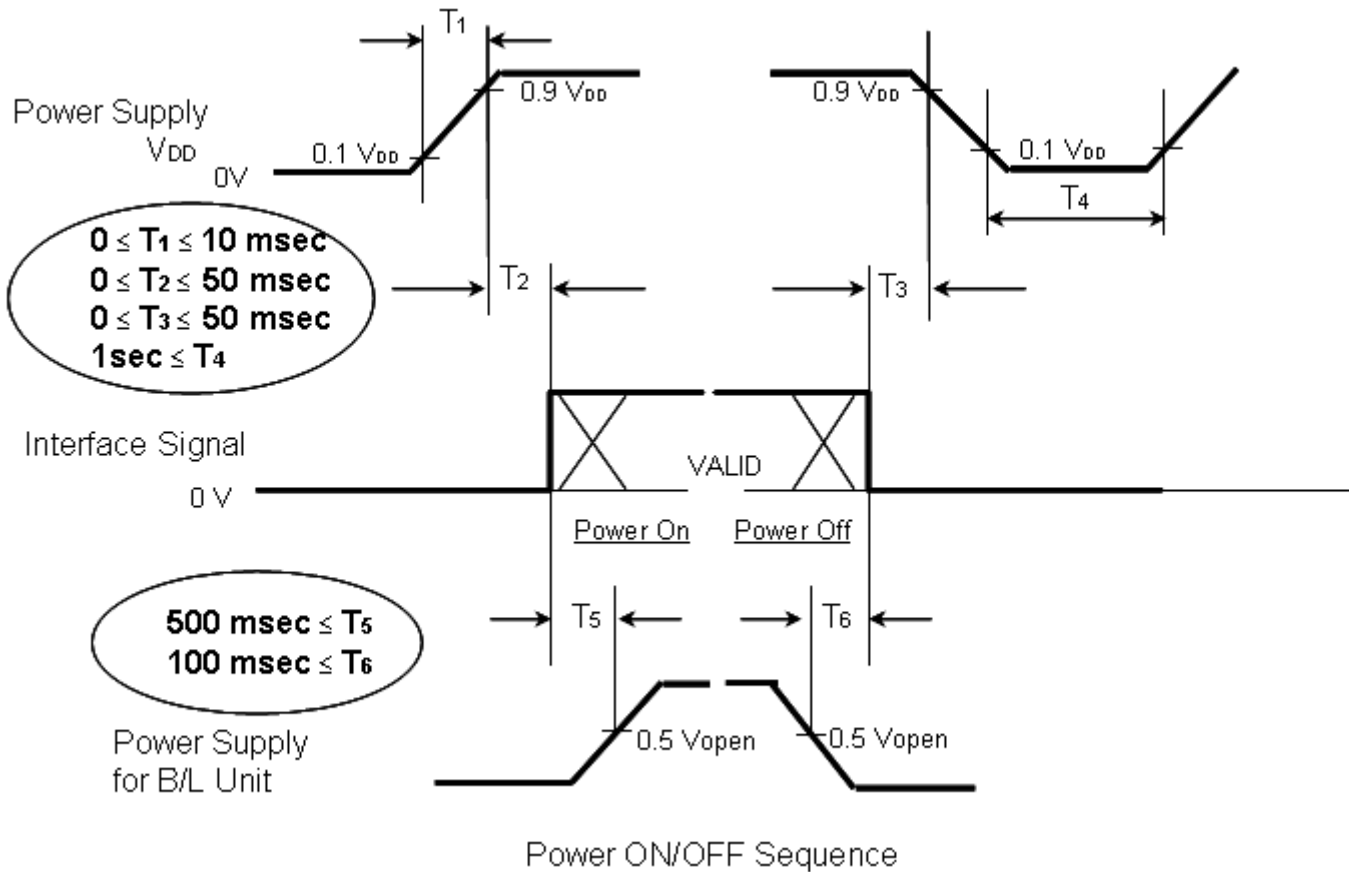

Note)

- (1) The supply voltage of the external system for the module input should be the same as the definition of V_{DD} .
- (2) Apply the lamp voltage within the LCD operation range. When the back-light turns on before the LCD operation or the LCD turns off before the Back-light turns off, the display may momentarily become white.
- (3) In case of $V_{DD} = \text{off level}$, please keep the level of input signals on the low or keep a high impedance.
- (4) T_4 should be measured after the module has been fully discharged between power off and on period.
- (5) Interface signal shall not be kept at high impedance when the power is on.

7. Mechanical Outline Dimension

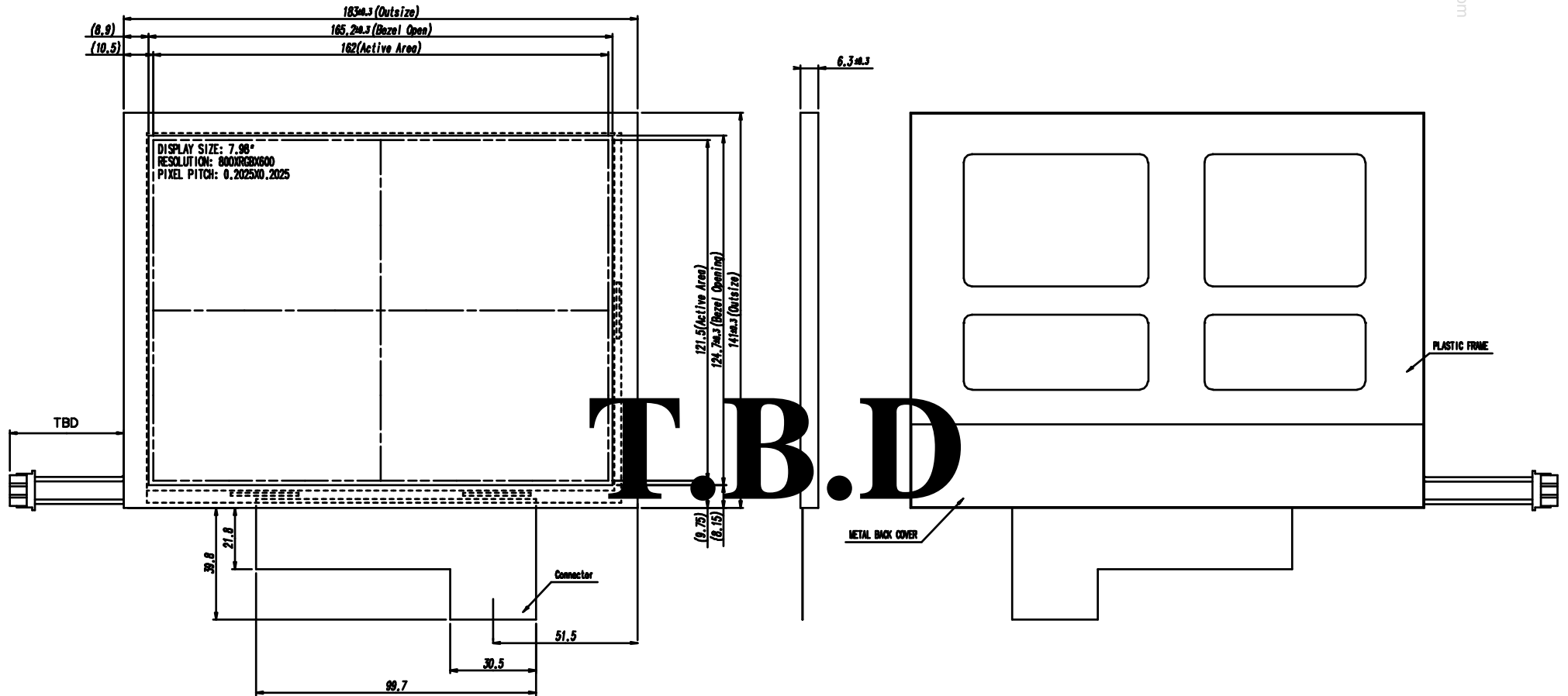

www.DataSheet4U.com

www.DataSheet4U.com

Doc . No	LMS800SF01	Ver No	000	Page	26/30
----------	------------	--------	-----	------	-------



8. Packing

www.DataSheet4U.com

T.B.D



9. Marking & Others

www.DataSheet4U.com

9.1 Packing case attach

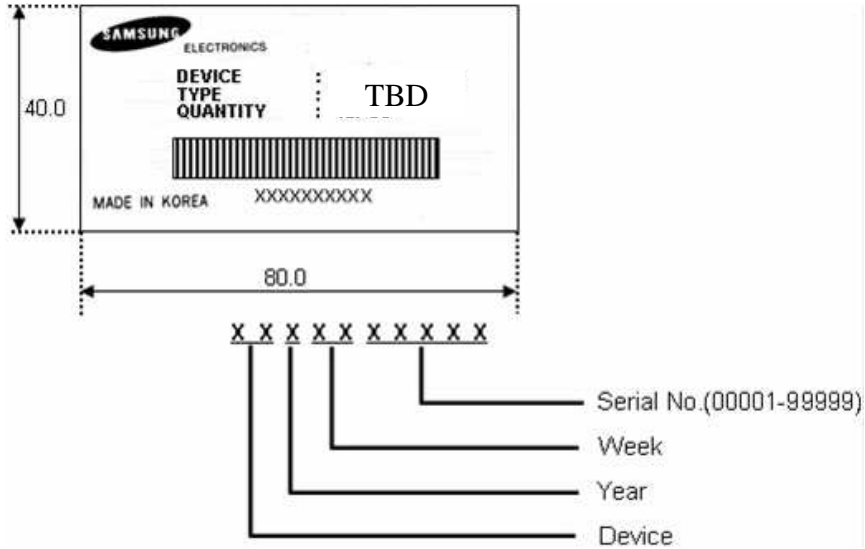

9.2 Module attach

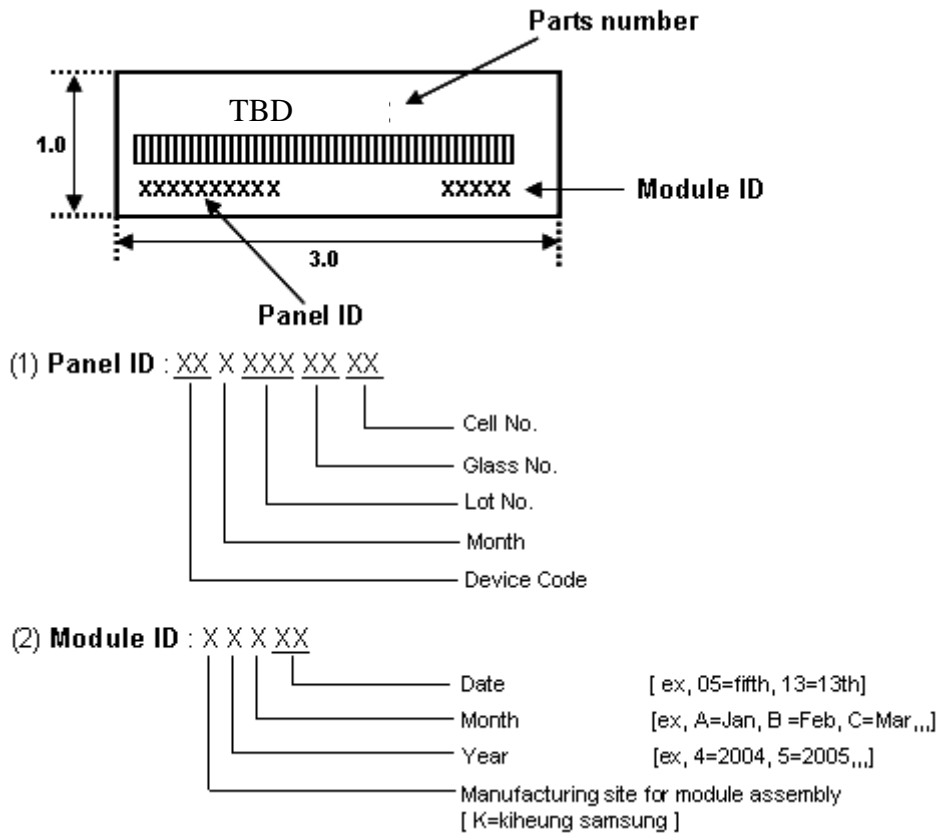

10. General Precautions

www.DataSheet4U.com

10.1 Handling

- (a) When the module is assembled, it should be attached to the system firmly. Be careful not to twist and bend the module.
- (b) Refrain from strong mechanical shock and / or any force to the module. In addition to damage, this may cause improper operation or damage to the module and back-light unit.
- (c) Note that polarizers are very fragile and could be easily damaged. Do not press or scratch the surface harder than a HB pencil lead.
- (d) Wipe off water droplets or oil immediately. If you leave the droplets for a long time, Staining and discoloration may occur.
- (e) If the surface of the polarizer is dirty, clean it using some absorbent cotton or soft cloth.
- (f) The desirable cleaners are water, IPA(Isopropyl Alcohol) or Hexane. Do not use Ketone type materials(ex. Acetone), Ethyl alcohol, Toluene, Ethyl acid or Methyl chloride. It might permanent damage to the polarizer due to chemical reaction.
- (g) If the liquid crystal material leaks from the panel, it should be kept away from the eyes or mouth. In case of contact with hands, legs or clothes, it must be washed away thoroughly with soap.
- (h) Protect the module from static , it may cause damage to the Integrated Gate Circuit.
- (i) Use finger-stalls with soft gloves in order to keep display clean during the incoming inspection and assembly process.
- (j) Do not disassemble the module.
- (k) Protection film for polarizer on the module shall be slowly peeled off just before use so that the electrostatic charge can be minimized.
- (l) Pins of I/F connector shall not be touched directly with bare hands



10.2 Storage

www.DataSheet4U.com

- (a) Do not leave the panel in high temperature, and high humidity for a long time. It is highly recommended to store the module with temperature from 0 to 35°C and relative humidity of less than 70%.
- (b) Do not store the TFT-LCD module in direct sunlight.
- (c) The module shall be stored in a dark place. It is prohibited to apply sunlight or fluorescent light during the store.

10.3 Operation

- (a) Do not connect, disconnect the module in the "Power On" condition.
- (b) Power supply should always be turned on/off by the "Power on/off sequence"

10.4 Others

- (a) The Liquid crystal is deteriorated by ultraviolet, do not leave it in direct sunlight and strong ultraviolet ray for many hours.
- (b) Avoid condensation of water. It may result in improper operation or disconnection of electrode.
- (c) Do not exceed the absolute maximum rating value. (the supply voltage variation, input voltage variation, variation in part contents and environmental temperature, and so on) Otherwise the panel may be damaged.
- (d) If the panel displays the same pattern continuously for a long period of time, it can be the situation when the image "Sticks" to the screen.
- (e) This panel has its circuitry FPC on the bottom side and should be handled carefully in order not to be stressed.

