



深圳市拓普微科技开发有限公司

SHENZHEN TOPWAY TECHNOLOGY CO., LTD.

LMT018DNBFWD-NCN-1

LCD Module User Manual

Prepared by: ChenZhiGuo Date: 2017-12-12	Checked by: Date:	Approved by: Date:
---	----------------------------------	-----------------------------------

Rev.	Descriptions	Release Date
0.1	Preliminary New release	2017-12-12

Table of Content

1. Basic Specifications	3
1.1 Block Diagram.....	3
1.2 Terminal Functions	4
2. Absolute Maximum Ratings	5
3. Electrical Characteristics	5
3.1 DC Characteristics	5
3.2 LED Backlight Circuit Characteristics	5
3.3 AC Characteristics	6
4. Optical Characteristics	7
5. Functions	9
5.1 Display Commands.....	9
5.2 Power off the LCD Module	12
5.3 Refreshing The LCD Module.....	12
6. Design and Handling Precaution	13

1. Basic Specifications

Screen Size(Diagonal) :	1.8"
Color Depth:	65k / 262k color
Number of dots :	160x128 x 3(RGB)
Active Area :	35.04x28.03 mm
Dot Pitch :	0.219x0.219 mm
Display Technology :	a-Si TFT active matrix
Display Mode :	Transmissive / Positive
Pixel Configuration :	RGB Stripe
Viewing Direction :	9H(gray scale inverse)(*1) 3H(*2)
Polarizer Surface Treatment:	Glare
Backlight Type:	LEDs
Outline Dimension :	54.0x48.0 x 8.3 mm (exclude IDC Header) (see dwg for details)
Operating Temperature :	-20 ~ +70°C (No Condensation)
Storage Temperature :	-30 ~ +80°C (No Condensation)
note:	
	*1. For saturated color display content (eg. pure-red, pure-green, pure-blue, or pure-colors-combinations)
	*2. For "color scales" display content
	*3. Color tone may slightly change by Temperature and Driving Condition.

1.1 Block Diagram

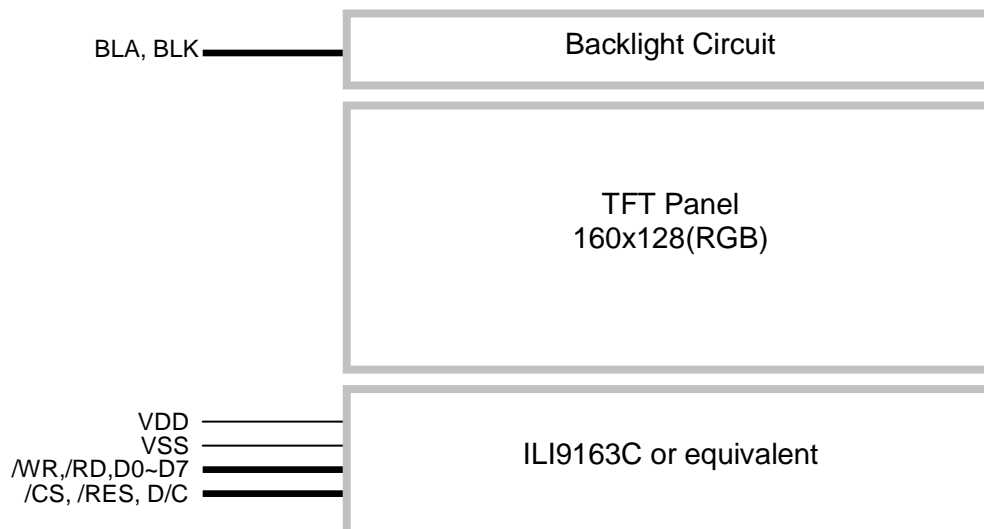

1.2 Terminal Functions

Pin No.		PIN Name	I/O	Descriptions
K1	K2			
1	7	/CS	Input	Chip Select /CS=L, enable access to the LCD module /CS=H, disable access to the LCD module
2	8	/RES	Input	Reset signal /RES = L, Initialization is executed /RES = H, Normal running.
3	9	D/C	Input	Register Select D/C = H, Transferring the Display Data D/C = L, Transferring the Control Data
4	10	/WR	Input	Write enable input, active LOW
5	11	/RD	Input	Read enable input, active LOW
6	19	D0	IO	Bi-directional tri-state Data bus
:	:	:	:	
13	12	D7	IO	
14	4	VDD	Power	Positive power supply
15	3,20	VSS	Power	Negative power supply,0V
16	2	BLA	Power	Positive power for LED backlight
17	1	BLK	Power	Negative power for LED backlight
18	5,6	NC	-	No connection leave open

2. Absolute Maximum Ratings

Items	Symbol	Min.	Max.	Unit	Condition
Supply Voltage	V_{DD}	-0.3	+4.6	V	$V_{SS} = 0V$
Input Voltage	V_{IN}	-0.3	+4.6	V	$V_{SS} = 0V$
Operating Temperature	T_{OP}	-20	+70	°C	No Condensation
Storage Temperature	T_{ST}	-30	+80	°C	No Condensation

Cautions:

Any Stresses exceeding the Absolute Maximum Ratings may cause substantial damage to the device. Functional operation of this device at other conditions beyond those listed in the specification is not implied and prolonged exposure to extreme conditions may affect device reliability.

3. Electrical Characteristics

3.1 DC Characteristics

$V_{SS}=0V, V_{DD}=2.8V, T_{OP}=25^{\circ}C$

Items	Symbol	MIN.	TYP.	MAX.	Unit	Condition / Application Pin
Operating Voltage	V_{DD}	2.6	2.8	3.3	V	VDD
Input High Voltage	V_{IH}	$0.8 \times V_{DD}$	-	V_{DD}	V	/RES, /CS, D/C,
Input Low Voltage	V_{IL}	V_{SS}	-	$0.2 \times V_{DD}$	V	D0~D7, /WR, /RD
Operating Current	I_{DD}	-	1.2	3.5	mA	VDD (*1)

Note: *1. $V_{DD}=2.8V$

3.2 LED Backlight Circuit Characteristics

$BLK=0V, I_{f_{BLA}}=30mA, T_{OP}=25^{\circ}C$

Items	Symbol	MIN.	TYP.	MAX.	Unit	Applicable Pin
Forward Voltage	$V_{f_{BLA}}$	-	3.0	-	V	BLA
Forward Current	$I_{f_{BLA}}$	-	30	-	mA	BLA
Color Coordinate (White)	X	0.270	-	0.315	-	
	Y	0.270	-	0.315	-	
Uniformity	ΔBp	80%	-	-	-	

Cautions:

Exceeding the recommended driving current could cause substantial damage to the backlight and shorten its lifetime.

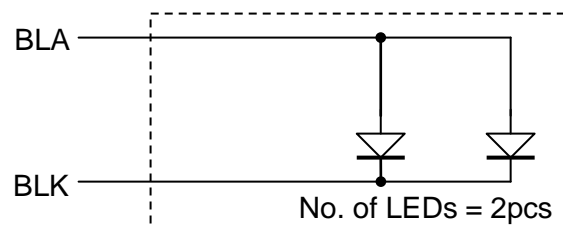

3.3 AC Characteristics

8080 Mode System Bus Timing

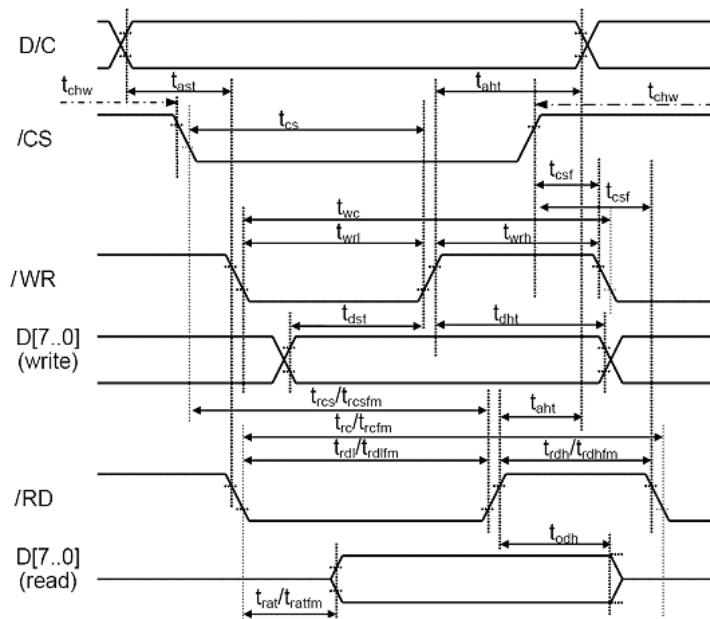

V_{SS}=0V, V_{DD}=2.8V, T_{OP}=25°C

Signal	Symbol	Parameter	min	max	unit	description
D/C	t _{ast}	Address setup time	0		ns	
	t _{ahd}	Address hold time(Write/Read)	10		ns	
/CS	t _{chw}	"S""H" Pulse Width	0		ns	
	t _{cs}	Chip Select setup time (Write)	10		ns	
	t _{rcs}	Chip Select setup time (Read ID)	45		ns	
	t _{rcsfm}	Chip Select setup time (Read FM)	355		ns	
	t _{csf}	Chip Select Wait time(Write/read)	10		ns	
/WR	t _{wc}	Write cycle	66		ns	
	t _{wrh}	Control pulse H duration	15		ns	
	t _{wrl}	Control pulse L duration	15		ns	
/RD	t _{rc}	Read cycle (ID)	160		ns	When read ID data
	t _{rdh}	Control pulse H duration(ID)	90		ns	
	t _{rdl}	Control pulse L duration(ID)	45		ns	
/RD	t _{rcfm}	Read cycle (FM)	450		ns	When read from frame memory
	t _{rdhfm}	Control pulse H duration (FM)	90		ns	
	t _{rdlfm}	Control pulse L duration (FM)	355		ns	
D[7..0]	t _{dst}	Data setup time	10		ns	For maximum CL = 30pF For minimum CL = 8pF
	t _{dht}	Data hold time	10		ns	
	t _{rat}	Read access time (ID)		40	ns	
	t _{ratfm}	Read access time (FM)		340	ns	
	t _{odh}	Output disable time	20	80	ns	

Note:

*1. Input signal rise/fall time should be less than 15ns .

*2. All timing is using 20% and 80% of VDD as the reference.

*3. Please refer to ILI9163B datasheet for details

Reset Timing

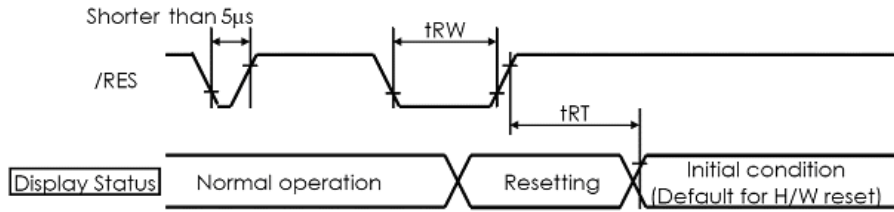

$V_{SS}=0V, V_{DD}=2.8V, T_{OP}=25^{\circ}C$

Item	Symbol	MIN.	TYP.	MAX.	Unit
Reset LOW pulse width	t_{RW}	1.0	-	-	us
Reset time	T_{RT}	-	-	120	ms

4. Optical Characteristics

Item	Symbol	Min.	Typ.	Max.	Unit	Note/ Condition	
Brightness	Bp	190	-	-	Cd/m ²	$\theta=0^{\circ}, \Phi=0^{\circ}$ (*1, *2)	
Uniformity	ΔBp	80%	-	-	-		
Viewing Angle	$\theta 1 (\Phi=90^{\circ} \text{ or } 270^{\circ})$	-50 ~ +40			Deg	(*3)	
	$\theta 2 (\Phi=0^{\circ} \text{ or } 180^{\circ})$	-50 ~ +50			deg		
Contrast Ratio	Cr	-	350	-	-	$\theta=0^{\circ}, \Phi=0^{\circ}$ (*4)	
Response Time	$T_{r+}+T_f$	-	30	-	Ms	$\theta=0^{\circ}, \Phi=0^{\circ}$ (*5)	
Color of CIE Coordinate	W	X	0.246	0.296	0.346		$\theta=0^{\circ}, \Phi=0^{\circ}$ (*1, *6)
		Y	0.265	0.315	0.365		
NTSC Ratio	S	42%	-	-	-	$\theta=0^{\circ}, \Phi=0^{\circ}$ (*1, *6)	

Note:

*1. Measurement

The data are measured after LEDs are turned on for 5 minutes. LCM displays full white. The brightness is the average value of 9 measured spots.

Measurement equipment PR-705 (Φ8mm)

Measuring condition:

- Measuring surroundings: Dark room.
- Measuring temperature: $T_a=25^{\circ}C$.
- Adjust operating voltage to get optimum contrast at the center of the display.

Measured value at the center point of LCD panel after more than 5 minutes while backlight turning on.

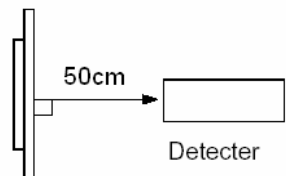

*2. The luminance uniformity

It is calculated by using following formula.

$$\Delta Bp = Bp (\text{Min.}) / Bp (\text{Max.}) \times 100 (\%)$$

Bp (Max.) = Maximum brightness in 9 measured spots

Bp (Min.) = Minimum brightness in 9 measured spots.

Measurement equipment PR-705 (Φ8mm)

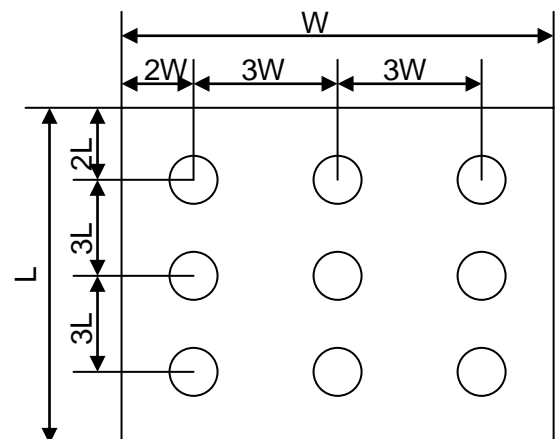

*3. The definition of viewing angle:
Refer to the graph below marked by θ and ϕ

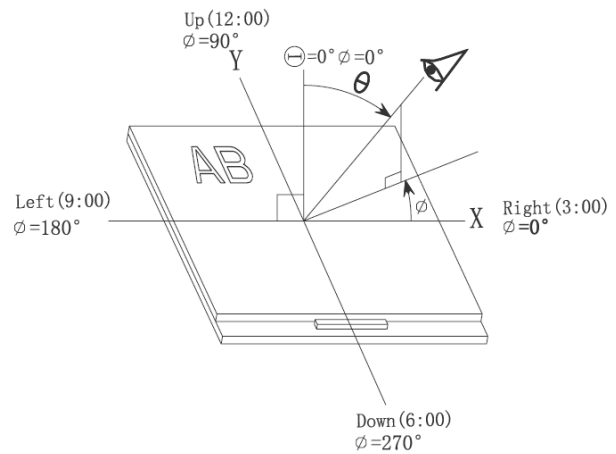

*4. The definition of contrast ratio (Test LCM using PR-705):

$$\text{Contrast Ratio(CR)} = \frac{\text{Luminance When LCD is at "White" state}}{\text{Luminance When LCD is at "Black" state}}$$

(Contrast Ratio is measured in optimum common electrode voltage)

*5. Definition of Response time.(Test LCD using DMS501):
The output signals of photo detector are measured when the input signals are changed from "black" to "white"(falling time) and from "white" to "black"(rising time), respectively. The response time is defined as the time interval between the 10% and 90% of amplitudes. Refer to figure as below.

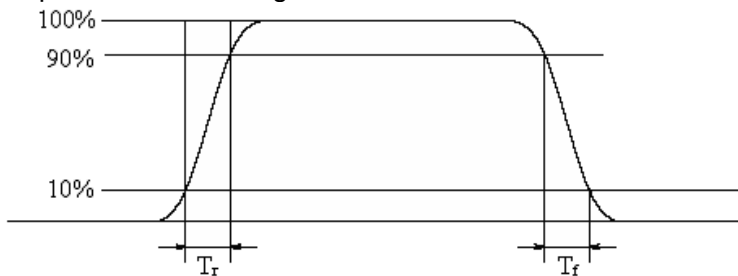

*6: Definition of Color of CIE Coordinate and NTSC Ratio.

$$S = \frac{\text{area of RGB triangle}}{\text{area of NTSC triangle}} \times 100\%$$

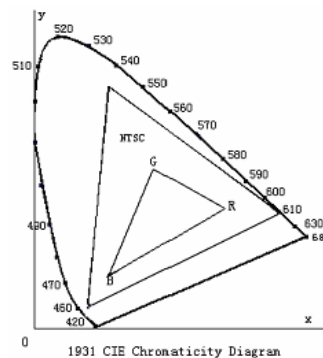

5. Functions

5.1 Display Commands

Code	Command	D17-D8	D7	D6	D5	D4	D3	D2	D1	D0	hex
00H	NOP (No Operation)	X	0	0	0	0	0	0	0	0	00h
01H	SoftwareReset	X	0	0	0	0	0	0	0	1	01h
04H	Read Display Id. Info	x	0	0	0	0	0	1	0	0	04h
	1 st Parameter	x	x	x	x	x	x	x	x	x	x
	2 nd Parameter	x	ID17	ID16	ID15	ID14	ID13	ID12	ID11	ID10	54h
	3 rd Parameter	x	ID27	ID26	ID25	ID24	ID23	ID22	ID21	ID20	80h
	4 th Parameter	x	ID37	ID36	ID35	ID34	ID33	ID32	ID31	ID30	66h
09H	Read Display Status	x	0	0	0	0	1	0	0	1	09h
	1 st Parameter	x	x	x	x	x	x	x	x	x	x
	2 nd Parameter	x	BOTSON	MY	MX	MV	ML	RGB	MH	ST24	00h
	3 rd Parameter	x	ST23	IFPF2	IFPF1	IFPF0	IDMON	PTLON	SLOUT	NORON	61h
	4 th Parameter	x	VSSON	ST14	INVON	ST12	ST11	DISON	TEON	GCS2	00h
	5 th Parameter	x	GCS1	GCS0	TELOM	HSON	VSON	PCKON	DEON	ST0	00h
0AH	Read Display Power Mode	x	0	0	0	0	1	0	1	0	0Ah
	1 st Parameter	x	x	x	x	x	x	x	x	x	X
	2 nd Parameter	x	BSTON	IDMON	PLTON	SLPOUT	NORON	DISON	D1	D0	08h
0BH	Read Display MADCTL	x	0	0	0	0	1	0	1	1	0Bh
	1 st Parameter	x	x	x	x	x	x	x	x	x	X
	2 nd Parameter	x	MY	MX	MV	ML	RGB	MH	D1	D0	00h
0CH	Read Display Pixel Format	x	0	0	0	0	1	1	0	0	0Ch
	1 st Parameter	x	x	x	x	x	x	x	x	x	x
	2 nd Parameter	x	VIPF3	VIPF2	VIPF1	VIPF0	D3	IFPF2	IFPF1	IFPF0	06h
0DH	Read Display Image Mode	x	0	0	0	0	1	1	0	1	0Dh
	1 st Parameter	x	x	x	x	x	x	x	x	x	x
	2 nd Parameter	x	VSSON	D6	INVON	D4	D3	GCS2	GCS1	GCS0	00h
0EH	Read Display Signal Mode	x	0	0	0	0	1	1	1	0	0Eh
	1 st Parameter	x	x	x	x	x	x	x	x	x	x
	2 nd Parameter	x	D7	D6	HSON	VSON	PCKON	DEON	D1	D0	00h
0FH	Read Display Signal Mode	x	0	0	0	0	1	1	1	1	0Fh
	1 st Parameter	x	x	x	x	x	x	x	x	x	x
	2 nd Parameter	x	RELD	FUND	D5	D4	D3	D2	D1	D0	00h
10H	Sleep In	x	0	0	0	1	0	0	0	0	10h
11H	Sleep Out	x	0	0	0	1	0	0	0	1	11h
12H	Partial Mode On	x	0	0	0	1	0	0	1	0	12h
13H	Normal Display Mode On	x	0	0	0	1	0	0	1	1	13h
20H	Display Inversion Off	x	0	0	1	0	0	0	0	0	20h
21H	Display Inversion On	x	0	0	1	0	0	0	0	1	21h
26H	Gamma Set	x	0	0	1	0	0	1	1	0	26h
	1 st Parameter	x	GC7	GC6	GC5	GC4	GC3	GC2	GC1	GC0	01h
28H	Display Off		0	0	1	0	1	0	0	0	28h
29H	Display On	x	0	0	1	0	1	0	0	1	29h
2AH	Column Address Set	x	0	0	1	0	1	0	1	0	2Ah
	1 st Parameter	x	XS15	XS14	XS13	XS12	XS11	XS10	XS9	XS8	-
	2 nd Parameter	x	XS7	XS6	XS5	XS4	XS3	XS2	XS1	XS0	-
	3 rd Parameter	x	XE15	XE14	XE13	XE12	XE11	XE10	XE9	XE8	-
	4 th Parameter	x	XE7	XE6	XE5	XE4	XE3	XE2	XE1	XE0	-
2BH	Page Address Set	x	0	0	1	0	1	0	1	1	2Bh
	1 st Parameter	x	YS15	YS14	YS13	YS12	YS11	YS10	YS9	YS8	-
	2 nd Parameter	x	YS7	YS6	YS5	YS4	YS3	YS2	YS1	YS0	-
	3 rd Parameter	x	YE15	YE14	YE13	YE12	YE11	YE10	YE9	YE8	-
	4 th Parameter	x	YE7	YE6	YE5	YE4	YE3	YE2	YE1	YE0	-

Code	Command	D17-D8	D7	D6	D5	D4	D3	D2	D1	D0	hex
2CH	Memory Write	x	0	0	1	0	1	1	0	0	2Ch
	1 st Parameter	D17-8	D7	D6	D5	D4	D3	D2	D1	D0	-
	:	x	:	:	:	:	:	:	:	:	:
	N th Parameter	D17-8	D7	D6	D5	D4	D3	D2	D1	D0	-
2DH	Color Setting for 4K, 65Kand 262K	x	0	0	1	0	1	1	0	1	2Dh
	1 st Parameter	x	x	x	R005	R004	R003	R002	R001	R000	-
	:	x	x	x	Rnn5	Rnn4	Rnn3	Rnn2	Rnn1	Rnn0	-
	32 nd parameter	x	x	x	R315	R314	R313	R312	R311	R310	-
	33 rd Parameter	x	x	x	G005	G004	G003	G002	G001	G000	-
	:	x	x	x	Gnn5	Gnn4	Gnn3	Gnn2	Gnn1	Gnn0	-
	96 th Parameter	x	x	x	G635	G634	G633	G632	G631	G630	-
	97 th Parameter	x	x	x	B005	B004	B003	B002	B001	B000	-
	:	x	x	x	Bnn5	Bnn4	Bnn3	Bnn2	Bnn1	Bnn0	-
	128 th Parameter	x	x	x	B315	B314	B313	B312	B311	B310	-
2EH	Memory Read	x	0	0	1	0	1	1	1	0	2Eh
	1 st Parameter	x	x	x	x	x	x	x	x	x	-
	2 nd Parameter	x	D17	D16	D15	D14	D13	D12	D11	D10	-
	:	x									-
	N th Parameter	x	Dn7	Dn6	Dn5	Dn4	Dn3	Dn2	Dn1	Dn0	-
30H	Partial Area	x	0	0	1	1	0	0	0	0	30h
	1 st Parameter	x	PSL15	PSL14	PSL13	PSL12	PSL11	PSL10	PSL9	PSL8	-
	2 nd Parameter	x	PSL7	PSL6	PSL5	PSL4	PSL3	PSL2	PSL1	PSL0	-
	3 rd Parameter	x	PEL15	PEL14	PEL13	PEL12	PEL11	PEL10	PEL9	PEL8	-
	4 th Parameter	x	PEL7	PEL6	PEL5	PEL4	PEL3	PEL2	PEL1	PEL0	-
33H	Vertical Scrolling Definition	x	0	0	1	1	0	0	1	1	33h
	1 st Parameter	x	TFA15	TFA14	TFA13	TFA12	TFA11	TFA10	TFA9	TFA8	-
	2 nd Parameter	x	TFA7	TFA6	TFA5	TFA4	TFA3	TFA2	TFA1	TFA0	-
	3 rd Parameter	x	VSA15	VSA14	VSA13	VSA12	VSA11	VSA10	VSA9	VSA8	-
	4 th Parameter	x	VSA7	VSA6	VSA5	VSA4	VSA3	VSA2	VSA1	VSA0	-
	5 th Parameter	x	BFA15	BFA14	BFA13	BFA12	BFA11	BFA10	BFA9	BFA8	-
	6 th Parameter	x	BFA7	BFA6	BFA5	BFA4	BFA3	BFA2	BFA1	BFA0	-
34H	Tearing EffectLine Off	x	0	0	1	1	0	1	0	0	34h
35H	Tearing EffectLine On	x	0	0	1	1	0	1	0	1	35h
	1 st Parameter	x	x	x	x	x	x	x	x	M	00h
36H	Memory Access Control	x	0	0	1	1	0	1	1	0	36h
	1 st Parameter	x	MY	MX	MV	ML	RGB	MH	x	x	00h
37H	VerticalScrolling StartAddress	x	0	0	1	1	0	1	1	1	37h
	1 st Parameter	x	SSA15	SSA14	SSA13	SSA12	SSA11	SSA10	SSA9	SSA8	00h
	2 nd Parameter	x	SSA7	SSA6	SSA5	SSA4	SSA3	SSA2	SSA1	SSA0	00h
38H	Idle Mode Off	x	0	0	1	1	1	0	0	0	38h
39H	Idle Mode On	x	0	0	1	1	1	0	0	1	39h
3AH	Interface PixelFormat	x	0	0	1	1	1	0	1	0	3Ah
	1 st Parameter	x	VIPF3	VIPF2	VIPF1	VIPF0	D3	IFPF2	IFPF1	IFPF0	66h
B1H	Frame Rate Control (In normal mode/Full colors)		1	0	1	1	0	0	0	1	B1h
	1 st Parameter		x	x	x	DIVA4	DIVA3	DIVA2	DIVA1	DIVA0	x
	2 nd Parameter		x	x	VPA5	VPA4	VPA3	VPA2	VPA1	VPA0	x
B2H	Frame Rate Control (In Idle mode/8-colors)		1	0	1	1	0	0	1	0	B2h
	1 st Parameter		x	x	x	DIVB4	DIVB3	DIVB2	DIVB1	DIVB0	x
	2 nd Parameter		x	x	VPB5	VPB4	VPB3	VPB2	VPB1	VPB0	x

Code	Command	D17-D8	D7	D6	D5	D4	D3	D2	D1	D0	hex
B3H	Frame Rate Control (In Partial mode/full colors)		1	0	1	1	0	0	1	1	B3h
	1 st Parameter		x	x	x	DIVC4	DIVC3	DIVC2	DIVC1	DIVC0	x
	2 nd Parameter		x	x	VPC5	VPC4	VPC3	VPC2	VPC1	VPC0	x
B4H	Display Inversion Control	x	1	0	1	1	0	1	0	0	B4h
	1 st Parameter	x	0	0	0	0	0	NLA	NLB	NLC	02H
B5H	RGB Interface Blanking Porch setting	x	1	0	1	1	0	1	0	1	B5h
	1 st Parameter	x	x	x	HBP5	HBP4	HBP3	HBP2	HBP1	HBP0	08h
	2 nd Parameter	x	VBP7	VBP6	VBP5	VBP4	VBP3	VBP2	VBP1	VBP0	03h
	3 rd Parameter	x	x	x	x	x	x	x	VBP9	VBP8	00h
B6H	Display Function Set	x	1	0	1	1	0	1	1	0	B6h
	1 st Parameter		x	x	NO1	NO0	SDT1	SDT0	EQ1	EQ2	06h
	2 nd Parameter		x	x	x	X	x	PTG0	PT1	PT0	02h
B7H	Source Driver Direction Control	x	1	0	1	1	0	1	1	1	B7h
	1 st Parameter	x	0	0	0	0	0	0	0	CRL	00h
B8H	Gate Driver Direction Control	x	1	0	1	1	1	0	0	0	B8h
	1 st Parameter	x	0	0	0	0	0	0	0	CTB	00h
C0H	Power_ Control1	x	1	1	0	0	0	0	0	0	C0h
	1 st Parameter	x	0	0	0	VRH4	VRH3	VRH2	VRH1	VRH0	x
	2 nd Parameter	x	0	0	0	0	0	VC2	VC1	VC0	02h
C1H	Power_ Control2	x	1	1	0	0	0	0	0	1	C1h
	1 st Parameter	x	0	0	0	0	0	BT2	BT1	BT0	07h
C2H	Power_ Control3	x	1	1	0	0	0	0	1	0	C2h
	1 st Parameter	x	0	0	0	0	0	APA2	APA1	APA0	00h
C3H	Power_ Control4	x	1	1	0	0	0	0	1	1	C3h
	1 st Parameter	x	0	0	0	0	0	APB2	APB1	APB0	00h
C4H	Power_ Control 5	x	1	1	0	0	0	1	0	0	C4h
	1 st Parameter	x	0	0	0	0	0	APC2	APC1	APC1	01h
C5H	VCOM_ Control 1	x	1	1	0	0	0	1	0	1	C5h
	1 st Parameter	x	x	VMH6	VMH5	VMH4	VMH3	VMH2	VMH1	VMH0	-
	2 nd Parameter	x	0	VML6	VML5	VML4	VML3	VML2	VML1	VML0	-
C6H	VCOM_ Control 2	x	1	1	0	0	0	1	1	0	C6h
	1 st Parameter	x	0	0	VMA5	VMA4	VMA3	VMA2	VMA1	VMA0	13h/06h
C7H	VCOM OffsetControl	x	1	1	0	0	0	1	1	1	C7h
	1 st Parameter	0	nVM*	VMF6	VMF5	VMF4	VMF3	VMF2	VMF1	VMF0	40h
D3H	Write ID4Value	x	1	1	0	1	0	0	1	1	D3h
	1 st Parameter	x	x	x	x	x	x	x	x	x	x
	2 nd Parameter	x	ID417	ID416	ID415	ID414	ID413	ID412	ID411	ID410	91h
	3 rd Parameter	x	ID427	ID426	ID425	ID424	ID423	ID422	ID421	ID420	63h
	4 th Parameter	x	x	x	x	x	ID433	ID432	ID431	ID430	00h
	5 th Parameter	x	x	x	x	x	x	x	x	x	x
D5H	NV Memory Function Controller(1)	x	1	1	0	1	1	0	1	0	D5h
	1 st Parameter	x	ID33	ID32	ID31	ID30	ID23	ID22	ID21	ID20	00h
	2 nd Parameter	x	OTP_ BS	0	0	0	OTP_ VMF3	OTP_ VMF2	OTP_ VMF1	OTP_ VMF0	00h
D6H	NV Memory Function Controller(2)	x	1	1	0	1	1	0	1	0	D6h
	1 st Parameter	x	OTP_D[7]	OTP_ D[6]	OTP_ D[5]	OTP_ D[4]	OTP_ D[3]	OTP_ D[2]	OTP_ D[1]	OTP_ D[0]	00h
	2 nd Parameter	x	0	0	0	0	0	0	OTP_ TP[1]	OTP_ TP[0]	00h
D7H	NV Memory Function Controller(3)	x	1	1	0	1	1	0	1	0	D7h
	1 st Parameter	x	0	1	0	1	0	1	0	1	55h
	2 nd Parameter	x	1	0	1	0	1	0	1	0	AAh
	3 rd Parameter	x	0	1	1	0	0	1	1	0	66h

Code	Command	D17-D8	D7	D6	D5	D4	D3	D2	D1	D0	hex
DAH	Read ID1	x	1	1	0	1	1	0	1	0	DAh
	1 st Parameter	x	x	x	x	x	x	x	x	x	x
	2 nd Parameter	x	ID17	ID16	ID15	ID14	ID13	ID12	ID11	ID10	54h
DBH	Read ID2	x	1	1	0	1	1	0	1	1	DBh
	1 st Parameter	x	x	x	x	x	x	x	x	x	x
	2 nd Parameter	x	1	ID26	ID25	ID24	ID23	ID22	ID21	ID20	80h
DCH	Read ID3	x	1	1	0	1	1	1	0	0	DCh
	1 st Parameter	x	x	x	x	x	x	x	x	x	x
	2 nd Parameter	x	ID37	ID36	ID35	ID34	ID33	ID32	ID31	ID30	66h
E0H	Positive Gamma Correction Setting		1	1	1	0	0	0	0	0	E0h
	1 st Parameter		x	x	VP0[5:0]						-
	2 nd Parameter		x	x	VP1[5:0]						-
	3 rd Parameter		x	x	VP2[5:0]						-
	4 th Parameter		x	x	VP4[5:0]						-
	5 th Parameter		x	x	VP6[5:0]						-
	6 th Parameter		x	x	x	VP13[4:0]					-
	7 th Parameter		x	VP20[6:0]						-	
	8 th Parameter			VP36[3:0]			VP27[3:0]			-	
	9 th Parameter		x	VP43[6:0]						-	
	10 th Parameter		x	VP50[5:0]						-	
	11 st Parameter		x	x	VP57[5:0]						-
	12 nd Parameter		x	x	VP59[5:0]						-
	13 rd Parameter		x	x	VP61[5:0]						-
	14 th Parameter		x	x	VP62[5:0]						-
15 th Parameter		x	x	VP63[5:0]						-	
E1H	Negative Gamma Correction Setting		1	1	1	0	0	0	0	1	E1h
	1 st Parameter		x	x	VN63[5:0]						-
	2 nd Parameter		x	x	VN62[5:0]						-
	3 rd Parameter		x	x	VN61[5:0]						-
	4 th Parameter		x	x	VN59[5:0]						-
	5 th Parameter		x	x	VN57[5:0]						-
	6 th Parameter		x	x	x	VN50[4:0]					-
	7 th Parameter		x	x	VN43[6:0]						-
	8 th Parameter			VN27[3:0]			VN36[3:0]			-	
	9 th Parameter		x	VN20[6:0]						-	
	10 th Parameter		x	x	VN13[5:0]						-
	11 st Parameter		x	x	VN6[5:0]						-
	12 nd Parameter		x	x	VN4[5:0]						-
	13 rd Parameter		x	x	VN2[5:0]						-
	14 th Parameter		x	x	VN1[5:0]						-
15 th Parameter		x	x	VN0[5:0]						-	
F2H	GAM_R_SEL		1	1	1	1	0	0	1	0	F2h
	1 st Parameter		x	x	x	x	x	x	x	GAM_R_SEL	Write

Notes:

1. There will be no abnormal visible effects on the display when S/W or H/W Reset are applied.
2. After Powered-On Reset finishes within 10% after both VDD & VDDI are applied.
3. Mode 1 means Tearing Effect Output Line consists of V-Blanking Information only.
4. Please refer to ILI9163B datasheet for details

5.2 Power off the LCD Module

It recommends that enter Sleep Mode before power off the LCD module.

5.3 Refreshing The LCD Module

It recommends that the operating modes and display contents be refreshed periodically to prevent the effect of unexpected noise.

6. Design and Handling Precaution

1. The LCD panel is made by glass. Any mechanical shock (eg. dropping from high place) will damage the LCD module.
2. Do not add excessive force on the surface of the display, which may cause the Display color change abnormally.
3. The polarizer on the LCD is easily get scratched. If possible, do not remove the LCD protective film until the last step of installation.
4. Never attempt to disassemble or rework the LCD module.
5. Only Clean the LCD with Isopropyl Alcohol or Ethyl Alcohol. Other solvents (eg. water) may damage the LCD.
6. When mounting the LCD module, make sure that it is free from twisting, warping and distortion.
7. Ensure to provide enough space (with cushion) between case and LCD panel to prevent external force adding on it, or it may cause damage to the LCD or degrade the display result.
8. Only hold the LCD module by its side. Never hold LCD module by add force on the heat seal or TAB.
9. Never add force to component of the LCD module. It may cause invisible damage or degrade of the reliability.
10. LCD module could be easily damaged by static electricity. Be careful to maintain an optimum anti-static work environment to protect the LCD module.
11. When peeling off the protective film from LCD, static charge may cause abnormal display pattern. It is normal and will resume to normal in a short while.
12. Take care and prevent get hurt by the LCD panel sharp edge.
13. Never operate the LCD module exceed the absolute maximum ratings.
14. Keep the signal line as short as possible to prevent noisy signal applying to LCD module.
15. Never apply signal to the LCD module without power supply.
16. IC chip (eg. TAB or COG) is sensitive to the light. Strong lighting environment could possibly cause malfunction. Light sealing structure casing is recommend.
17. LCD module reliability may be reduced by temperature shock.
18. When storing the LCD module, avoid exposure to the direct sunlight, high humidity, high temperature or low temperature. They may damage or degrade the LCD module