



深圳市拓普微科技开发有限公司

SHENZHEN TOPWAY TECHNOLOGY CO., LTD.

LMT024ENHFWL-NBN

LCD Module User Manual

Prepared by: Chen Rili Date: 2017-12-15	Checked by: Date:	Approved by: Date:
--	----------------------------------	-----------------------------------

Rev.	Descriptions	Release Date
0.1	Preliminary New release	2017-12-15

Table of Content

1. Basic Specifications	3
1.1 Block Diagram	3
1.2 Terminal Functions	4
2. Absolute Maximum Ratings	5
3. Electrical Characteristics	5
3.1 DC Characteristics	5
3.2 AC Characteristics	6
4. Functions	8
4.1 Display Commands	8
4.2 Power off the LCD Module	13
4.3 Refreshing The LCD Module	13
5. Optical Characteristics	14
6. Design and Handling Precaution	17

1. Basic Specifications

Screen Size(Diagonal) :	2.4"
Color Depth:	65K/262k color
Number of dots :	320 x 240(RGB)
Active Area :	48.96 x 36.72 mm
Dot Pitch :	0.153 x 0.153 mm
Display Technology :	a-Si TFT active matrix
Display Mode :	Transmissive/Positive
Pixel Configuration :	RGB Stripe
Viewing Direction :	9H (*1) (gray scale inverse) 3H (*2)
Backlight Type:	LEDs
Outline Dimension :	71.5 x 49.1 x 7.7MAX
Operating Temperature :	-20 ~ +70°C (No Condensation)
Storage Temperature :	-30 ~ +80°C (No Condensation)

Note:

- *1. For saturated color display content (eg. pure-red, pure-green, pure-blue or pure-colors-combinations).
- *2. For "color scales" display content.
- *3. Color tone may slightly change by temperature and driving condition.

1.1 Block Diagram

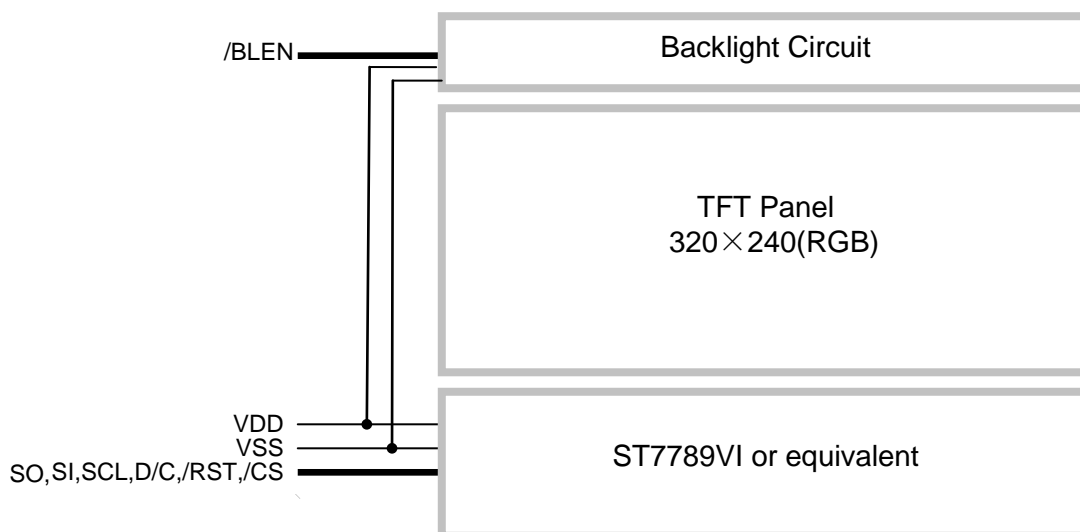

1.2 Terminal Functions

Pin No.	PIN Name	I/O	Descriptions
1	VSS	P	Negative power supply ,0V
2	VSS	P	Negative power supply ,0V
3	/BLEN	I	Backlight enable signal, active low
4	VDD	P	Positive power supply
5	VDD	P	Positive power supply
6	SI	I	Serial data input
7	SCL	I	Serial clock input
8	D/C	I	Command or display data selection: D/C= H, Transferring the Display Data D/C = L, Transferring the Control Data
9	/RST	I	Reset Signal: /RES = L, Initialization is executed /RES = H, Normal running
10	/CS	I	Chip Select Signal: /CS=L, enable access to the LCD module /CS=H, disable access to the LCD module
11	SO	O	Serial data output
12~28	NC	--	NO connection

2. Absolute Maximum Ratings

Items	Symbol	Min.	Max.	Unit	Condition
Supply Voltage	VDD	-0.3	+7.0	V	VSS = 0V
Input Voltage	/RST, SI,SO D/C,SCL,/CS	-0.3	IOVDD +0.5	V	VSS = 0V
Operating Temperature	T _{OP}	-20	+70	°C	-
Storage Temperature	T _{ST}	-30	+80	°C	-

Cautions:

Any Stresses exceeding the Absolute Maximum Ratings may cause substantial damage to the device. Functional operation of this device at other conditions beyond those listed in the specification is not implied and prolonged exposure to extreme conditions may affect device reliability.

3. Electrical Characteristics

3.1 DC Characteristics

VDD=5V, VSS=0V, T_{OP}=25°C

Items	Symbol	MIN.	TYP.	MAX.	Unit	Application Pin
Supply Voltage	VDD	4.8	5	5.2	V	VDD
Input High Voltage	V _{IH}	2.3	-	3.3	V	/RST, SI,D/C,SCL,/CS
Input Low Voltage	V _{IL}	-	-	1.0	V	
Output High Voltage	V _{OH}	2.6	-	-	V	SO
Output Low Voltage	V _{OL}	-	-	0.7	V	
Operating Current	I _{DD}	-	78.0	100	mA	Backlight are ON
	I _{DD}	-	5.0	12.5	mA	Backlight are OFF

3.2 AC Characteristics

SPI Bus Timing

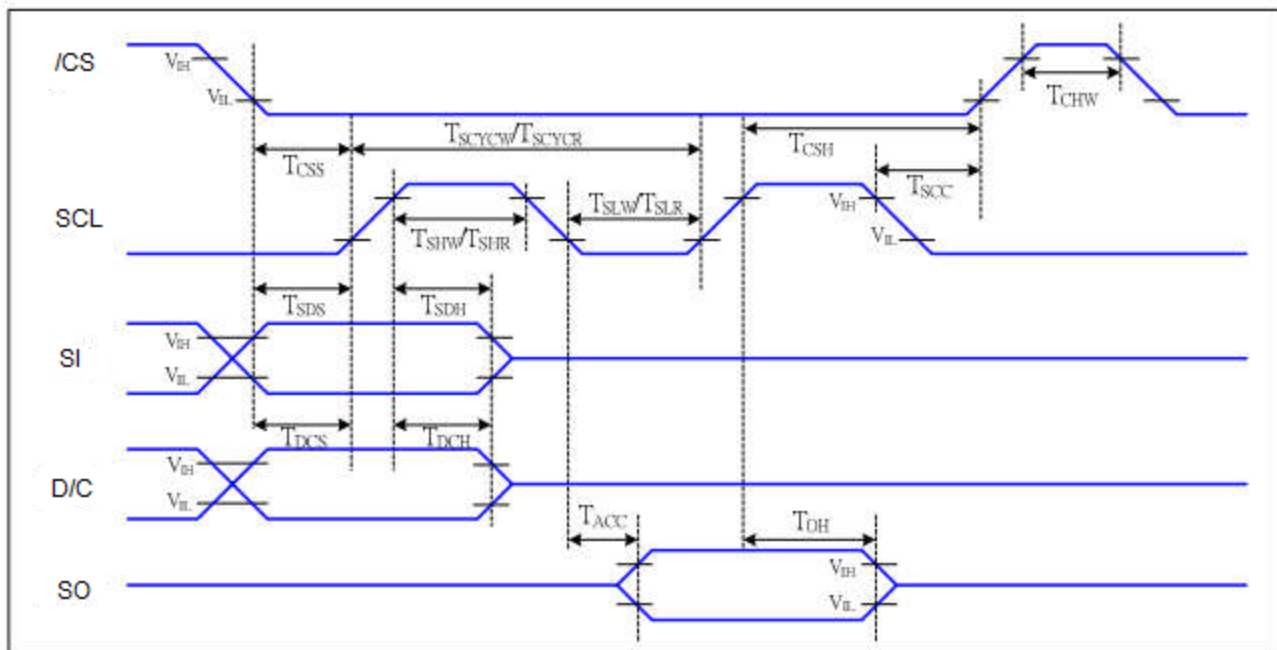

Figure 5 4-line serial Interface Timing Characteristics

V_{DD}=5.0V, V_{SS}=0V, T_{OP}=25°C

Signal	Symbol	Parameter	min	max	unit	description
D/C	T _{DCS}	D/CX setup time	10	-	ns	
	T _{DCH}	D/CX hold time	10	-	ns	
/CS	T _{CSS}	Chip select setup time(write)	15	-	ns	
	T _{CSH}	Chip select hold time(write)	15	-	ns	
	T _{CSS}	Chip select setup time(read)	60	-	ns	
	T _{SCC}	Chip select hold time(read)	65	-	ns	
	T _{CHW}	Chip select "H" pulse width	40	-	ns	
SCL	T _{SCYC^w}	Serial clock cycle(write)	16	-	ns	-write command & data ram
	T _{SHW}	SCL "H" pulse width(write)	7	-	ns	
	T _{SLW}	SCL "L" pulse width(write)	7	-	ns	
	T _{SCYCR}	Serial clock cycle(read)	150	-		-read command & data ram
	T _{SHR}	SCL "H" pulse width(read)	60	-		
	T _{SLR}	SCL "L" pulse width(read)	60	-		
SI	T _{SDS}	Data setup time	7	-	ns	When read ID data
	T _{SDH}	Data hold time	7	-	ns	
SO	T _{ACC}	Access time	10	50	ns	For maximum CL=30pF For minimum CL=8pF
	T _{OH}	Output disable time	15	50	ns	

Note:

*1. Input signal rise/fall time should be less than 15ns .

*2. All timing is using 20% and 80% of V_{DD} as the reference.

*3. Please refer to ST7789VI datasheet for details

Reset Timing

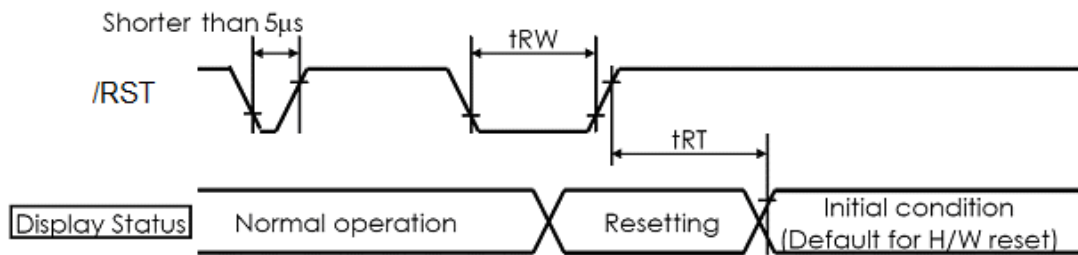

VDD=5.0V, VSS=0V, T_{OP}=25°C

Item	Symbol	MIN.	TYP.	MAX.	Unit
Reset LOW pulse width	T_{RW}	10	-	-	µs
Reset time	T_{RT}	-	-	120	ms

4. Functions

4.1 Display Commands

Instruction	D/CX	WRX	RDX	D17-8	D7	D6	D5	D4	D3	D2	D1	D0	Hex	Function
NOP	0	↑	1	-	0	0	0	0	0	0	0	0	(00h)	No operation
SWRESET	0	↑	1	-	0	0	0	0	0	0	0	1	(01h)	Software reset
RDDID	0	↑	1	-	0	0	0	0	0	1	0	0	(04h)	Read display ID
	1	1	↑	-	-	-	-	-	-	-	-	-		Dummy read
	1	1	↑	-	ID17	ID16	ID15	ID14	ID13	ID12	ID11	ID10		ID1 read
	1	1	↑	-	ID27	ID26	ID25	ID24	ID23	ID22	ID21	ID20		ID2 read
	1	1	↑	-	ID37	ID36	ID35	ID34	ID33	ID32	ID31	ID30		ID3 read
RDDST	0	↑	1	-	0	0	0	0	1	0	0	1	(09h)	Read display status
	1	1	↑	-	-	-	-	-	-	-	-	-		Dummy read
	1	1	↑	-	BSTON	MY	MX	MV	ML	RGB	MH	ST24		-
	1	1	↑	-	ST23	IFPF2	IFPF1	IFPF0	IDMON	PTLON	SLOUT	NORON		-
	1	1	↑	-	ST15	ST14	INVON	ST12	ST11	DISON	TEON	GCS2		-
1	1	↑	-	GCS1	GCS0	TEM	ST4	ST3	ST2	ST1	ST0		-	
RDDPM	0	↑	1	-	0	0	0	0	1	0	1	0	(0Ah)	Read display power
	1	1	↑	-	-	-	-	-	-	-	-	-		Dummy read
	1	1	↑	-	BSTON	IDMON	PTLON	SLPOUT	NORON	DISON	0	0		
RDD MADCTL	0	↑	1	-	0	0	0	0	1	0	1	1	(0Bh)	Read display
	1	1	↑	-	-	-	-	-	-	-	-	-		Dummy read
	1	1	↑	-	MY	MX	MV	ML	RGB	MH	0	0		-
RDD COLMOD	0	↑	1	-	0	0	0	0	1	1	0	0	(0Ch)	Read display pixel
	1	1	↑	-	-	-	-	-	-	-	-	-		Dummy read
	1	1	↑	-	0	D6	D5	D4	0	D2	D1	D0		-
RDDIM	0	↑	1	-	0	0	0	0	1	1	0	1	(0Dh)	Read display image
	1	1	↑	-	-	-	-	-	-	-	-	-		Dummy read
	1	1	↑	-	VSSON	0	INVON	0	0	GC2	GC1	GC0		-
RDDSM	0	↑	1	-	0	0	0	0	1	1	1	0	(0Eh)	Read display signal
	1	1	↑	-	-	-	-	-	-	-	-	-		Dummy read

Instruction	D/CX	WRX	RDX	D17-8	D7	D6	D5	D4	D3	D2	D1	D0	Hex	Function
	1	1	↑	-	TEON	TEM	0	0	0	0	0	0		-
RDDSDR	0	↑	1	-	0	0	0	0	1	1	1	1	(0Fh)	Read display self-diagnostic result
	1	1	↑	-	-	-	-	-	-	-	-	-		Dummy read
	1	1	↑	-	D7	D6	0	0	0	0	0	0		-
SLPIN	0	↑	1	-	0	0	0	1	0	0	0	0	(10h)	Sleep in
SLPOUT	0	↑	1	-	0	0	0	1	0	0	0	1	(11h)	Sleep out
PTLON	0	↑	1	-	0	0	0	1	0	0	1	0	(12h)	Partial mode on
NORON	0	↑	1	-	0	0	0	1	0	0	1	1	(13h)	Partial off (Normal)
INVOFF	0	↑	1	-	0	0	1	0	0	0	0	0	(20h)	Display Inversion off
INVON	0	↑	1	-	0	0	1	0	0	0	0	1	(21h)	Display Inversion on
GAMSET	0	↑	1	-	0	0	1	0	0	0	0	1	(26h)	Display Inversion on
	1	↑	1	-	0	0	0	0	GC3	GC2	GC1	GC0		
DISPOFF	0	↑	1	-	0	0	1	0	1	0	0	0	(28h)	Display off
DISPON	0	↑	1	-	0	0	1	0	1	0	0	1	(29h)	Display on
CASET	0	↑	1	-	0	0	1	0	1	0	1	0	(2Ah)	Column address set
	1	↑	1	-	XS15	XS14	XS13	XS12	XS11	XS10	XS9	XS8		X address start:
	1	↑	1		XS7	XS6	XS5	XS4	XS3	XS2	XS1	XS0		$0 \leq XS \leq X$
	1	↑	1		XE15	XE14	XE13	XE12	XE11	XE10	XE9	XE8		X address start:
	1	↑	1		XE7	XE6	XE5	XE4	XE3	XE2	XE1	XE0		$S \leq XE \leq X$
RASET	0	↑	1	-	0	0	1	0	1	0	1	1	(2Bh)	Row address set
	1	↑	1	-	YS15	YS14	YS13	YS12	YS11	YS10	YS9	YS8		Y address start:
	1	↑	1		YS7	YS6	YS5	YS4	YS3	YS2	YS1	YS0		$0 \leq YS \leq Y$
	1	↑	1		YE15	YE14	YE13	YE12	YE11	YE10	YE9	YE8		Y address start:
	1	↑	1		YE7	YE6	YE5	YE4	YE3	YE2	YE1	YE0		$S \leq YE \leq Y$
RAMWR	0	↑	1	-	0	0	1	0	1	1	0	0	(2Ch)	Memory write
	1	↑	1	D1[17:8]	D1[7]	D1[6]	D1[5]	D1[4]	D1[3]	D1[2]	D1[1]	D1[0]		Write data
	1	↑	1	Dx[17:8]	Dx[7]	Dx[6]	Dx[5]	Dx[4]	Dx[3]	Dx[2]	Dx[1]	Dx[0]		
	1	↑	1	Dn[17:8]	Dn[7]	Dn[6]	Dn[5]	Dn[4]	Dn[3]	Dn[2]	Dn[1]	Dn[0]		
RAMRD	0	↑	1	-	0	0	1	0	1	1	0	(2Eh)	Memory read	

Instruction	D/CX	WRX	RDX	D17-8	D7	D6	D5	D4	D3	D2	D1	D0	Hex	Function
	1	1	↑	-	-	-	-	-	-	-	-	-		Dummy read
	1	1	↑	D1[17:8]	D1[7]	D1[6]	D1[5]	D1[4]	D1[3]	D1[2]	D1[1]	D1[0]		Read data
	1	1	↑	Dx[17:8]	Dx[7]	Dx[6]	Dx[5]	Dx[4]	Dx[3]	Dx[2]	Dx[1]	Dx[0]		
	1	1	↑	Dn[17:8]	Dn[7]	Dn[6]	Dn[5]	Dn[4]	Dn[3]	Dn[2]	Dn[1]	Dn[0]		
PTLAR	0	↑	1	-	0	0	1	1	0	0	0	0	(30h)	Partial start/end address set
	1	↑	1	-	PSL15	PSL14	PSL13	PSL12	PSL11	PSL10	PSL9	PSL8		Partial start address: (0, 1, 2, ..P)
	1	↑	1	-	PSL7	PSL6	PSL5	PSL4	PSL3	PSL2	PSL1	PSL0		
	1	↑	1	-	PEL15	PEL14	PEL13	PEL12	PEL11	PEL10	PEL9	PEL8		Partial end address (0, 1, 2, 3, , P)
VSCRDEF	0	↑	1	-	0	0	1	1	0	0	1	1	(33h)	Vertical scrolling definition
	1	↑	1	-	TFA15	TFA14	TFA13	TFA12	TFA11	TFA10	TFA9	TFA8		
	1	↑	1	-	TFA7	TFA6	TFA5	TFA4	TFA3	TFA2	TFA1	TFA0		
	1	↑	1	-	VSA15	VSA14	VSA13	VSA12	VSA11	VSA10	VSA9	VSA8		
	1	↑	1	-	VSA7	VSA6	VSA5	VSA4	VSA3	VSA2	VSA1	VSA0		
	1	↑	1	-	BFA15	BFA14	BFA13	BFA12	BFA11	BFA10	BFA9	BFA8		
	1	↑	1	-	BFA7	BFA6	BFA5	BFA4	BFA3	BFA2	BFA1	BFA0		
TEOFF	0	↑	1	-	0	0	1	1	0	1	0	0	(34h)	Tearing effect line off
TEON	0	↑	1	-	0	0	1	1	0	1	0	1	(35h)	Tearing effect line on
	1	↑	1	-	-	-	-	-	-	-	-	TEM		
MADCTL	0	↑	1	-	0	0	1	1	0	1	1	0	(36h)	Memory data access control
	1	↑	1	-	MY	MX	MV	ML	RGB	0	0	0		-
VSCRSAADD	0	↑	1	-	0	0	1	1	0	1	1	1	(37h)	Vertical scrolling start address
	1	↑	1	-	VSP15	VSP14	VSP13	VSP12	VSP11	VSP10	VSP9	VSP8		
	1	↑	1	-	VSP7	VSP6	VSP5	VSP4	VSP3	VSP2	VSP1	VSP0		
IDMOFF	0	↑	1	-	0	0	1	1	1	0	0	0	(38h)	Idle mode off
IDMON	0	↑	1	-	0	0	1	1	1	0	0	1	(39h)	Idle mode on

Instruction	D/CX	WRX	RDX	D17-8	D7	D6	D5	D4	D3	D2	D1	D0	Hex	Function
COLMOD	0	↑	1	-	0	0	1	1	1	0	1	0	(3Ah)	Interface pixel format
	1	↑	1	-	0	D6	D5	D4	0	D2	D1	D0		Interface format
RAMWRC	0	↑	1	-	0	0	1	1	1	1	0	0	(3Ch)	Memory write continue
	1	↑	1	D1[17:8]	D1[7]	D1[6]	D1[5]	D1[4]	D1[3]	D1[2]	D1[1]	D1[0]		Write data
	1	↑	1	Dx[17:8]	Dx[7]	Dx[6]	Dx[5]	Dx[4]	Dx[3]	Dx[2]	Dx[1]	Dx[0]		
	1	↑	1	Dn[17:8]	Dn[7]	Dn[6]	Dn[5]	Dn[4]	Dn[3]	Dn[2]	Dn[1]	Dn[0]		
RAMRDC	0	↑	1	-	0	0	1	1	1	1	1	0	(3Eh)	Memory read continue
	1	1	↑	-	-	-	-	-	-	-	-	-		Dummy Read
	1	1	↑	D1[17:8]	D1[7]	D1[6]	D1[5]	D1[4]	D1[3]	D1[2]	D1[1]	D1[0]		
	1	1	↑	Dx[17:8]	Dx[7]	Dx[6]	Dx[5]	Dx[4]	Dx[3]	Dx[2]	Dx[1]	Dx[0]		
	1	1	↑	Dn[17:8]	Dn[7]	Dn[6]	Dn[5]	Dn[4]	Dn[3]	Dn[2]	Dn[1]	Dn[0]		
TESCAN	0	↑	1	-	0	1	0	0	0	1	0	0	(44h)	Get tear scanline
	1	↑	1	-	N15	N14	N13	N12	N11	N10	N9	N8		
	1	↑	1	-	N7	N6	N5	N4	N3	N2	N1	N0		
RDTESCAN	0	↑	1	-	0	1	0	0	0	1	0	1	(45h)	Get scanline
	1	1	↑	-	-	-	-	-	-	-	-	-		Dummy Read
	1	1	↑	-	-	-	-	-	-	-	N9	N8		
	1	1	↑	-	N7	N6	N5	N4	N3	N2	N1	N0		
WRDISBV	0	↑	1	-	0	1	0	1	0	0	0	1	(51h)	Write display brightness
	1	↑	1	-	DBV7	DBV6	DBV5	DBV4	DBV3	DBV2	DBV1	DBV0		
RDISBV	0	↑	1	-	0	1	0	1	0	0	1	0	(52h)	Read display brightness value
	1	1	↑	-	-	-	-	-	-	-	-	-		Dummy read
	1	1	↑	-	DBV7	DBV6	DBV5	DBV4	DBV3	DBV2	DBV1	DBV0		
WRCTRLD	0	↑	1	-	0	1	0	1	0	0	1	1	(53h)	Write CTRL display
	1	↑	1	-	0	0	BCTRL	0	DD	BL	0	0		
RDCTRLD	0	↑	1	-	0	1	0	1	0	1	0	0	(54h)	Read CTRL value display
	1	1	↑	-	-	-	-	-	-	-	-	-		Dummy read
	1	1	↑	-	0	0	BCTRL	0	DD	BL	0	0		

Instruction	D/CX	WRX	RDX	D17-8	D7	D6	D5	D4	D3	D2	D1	D0	Hex	Function
WRCACE	0	↑	1	-	0	1	0	1	0	1	0	1	(55h)	Write content adaptive brightness control and Color enhancemet
	1	↑	1	-	CECTRL	0	CE1	CE0	0	0	C1	C0		
RDCABC	0	↑	1	-	0	1	0	1	0	1	1	0	(56h)	Read content adaptive brightness control
	1	↑	↑	-	-	-	-	-	-	-	-	-		Dummy read
	1	↑	↑	-	0	CECTRL	0	0	0	0	C1	C0		
WRCABCMB	0	↑	1	-	0	1	0	1	1	1	1	0	(5Eh)	Write CABC minimum brightness
	1	↑	1	-	CMB7	CMB6	CMB5	CMB4	CMB3	CMB2	CMB1	CMB0		
RDCABCMB	0	↑	1	-	0	1	0	1	1	1	1	1	(5Fh)	Read CABC minimum brightness
	1	↑	↑	-	-	-	-	-	-	-	-	-		Dummy read
	1	↑	↑	-	CMB7	CMB6	CMB5	CMB4	CMB3	CMB2	CMB1	CMB0		
RDABCSDR	0	↑	1	-	0	1	1	0	1	0	0	0	(68h)	Read Automatic Brightness Control Self-Diagnostic Result
	1	↑	↑	-	-	-	-	-	-	-	-	-		Dummy read
	1	↑	↑	-	D7	D6	0	0	0	0	0	0		-
RDID1	0	↑	1	-	1	1	0	1	1	0	1	0	(DAh)	Read ID1
	1	↑	↑	-	-	-	-	-	-	-	-	-		Dummy read
	1	↑	↑	-	ID17	ID16	ID15	ID14	ID13	ID12	ID11	ID10		Read parameter
RDID2	0	↑	1	-	1	1	0	1	1	0	1	1	(DBh)	Read ID2
	1	↑	↑	-	-	-	-	-	-	-	-	-		Dummy read
	1	↑	↑	-	ID27	ID26	ID25	ID24	ID23	ID22	ID21	ID20		Read parameter
RDID3	0	↑	1	-	1	1	0	1	1	1	0	0	(DCh)	Read ID3

Instruction	D/CX	WRX	RDX	D17-8	D7	D6	D5	D4	D3	D2	D1	D0	Hex	Function
	1	1	↑	-	-	-	-	-	-	-	-	-		Dummy read
	1	1	↑		ID37	ID36	ID35	ID34	ID33	ID32	ID31	ID30		Read parameter

Note: Please refer to Sitronix [ST7789VI](#) data sheet for more details.

4.2 Power off the LCD Module

It recommends that enter Sleep Mode before power off the LCD module.

4.3 Refreshing The LCD Module

It recommends that the operating modes and display contents be refreshed periodically to prevent the effect of unexpected noise.

5. Optical Characteristics

Item	Symbol	Min.	Typ.	Max.	Unit	Note/ Condition
Brightness	Bp	280	300	-	Cd/m ²	$\theta=0^\circ, \Phi=0^\circ$ (*1,*2)
Uniformity	ΔBp	80%	-	-	-	
Viewing Angle	$\theta T(\Phi=90^\circ)$	-60~+50			Deg	(*3)
	$\theta B(\Phi=270^\circ)$				Deg	
	$\theta L(\Phi=180^\circ)$	-60~+60			Deg	
	$\theta R(\Phi=0^\circ)$				Deg	
Contrast Ratio	Cr	-	350	-	-	$\theta=0^\circ$
Response Time	T _{ON}	-	25	30	ms	$\theta=0^\circ, \Phi=0^\circ$ (*1,*5)
	T _{OFF}					
Color of CIE Coordinate	White	X	0.2435	0.2935	0.3335	$\theta=0^\circ, \Phi=0^\circ$ (*1,*6)
		Y	0.2644	0.3144	0.3644	
	Red	X	0.5355	0.5855	0.6355	
		Y	0.2798	0.3298	0.3798	
	Green	X	0.3039	0.3539	0.4039	
		Y	0.5408	0.5908	0.6408	
Blue	X	0.0988	0.1488	0.1988		
	Y	0.0429	0.0929	0.1429		
NTSC Ratio	S	-	53%	-	-	$\theta=0^\circ, \Phi=0^\circ$ (*1,*6)

Test Conditions:

- VDD=3.3V,LI=20mA(Backlight current), the ambient temperature is 25°C
- The test systems refer to *1and *3

Note:

*1. Measurement

The optical characteristics should be measured in dark room. After 5 minutes operation, the optical properties are measured at the center point of the LCD screen. All input terminals LCD panel must be ground when measuring the center area of the panel.

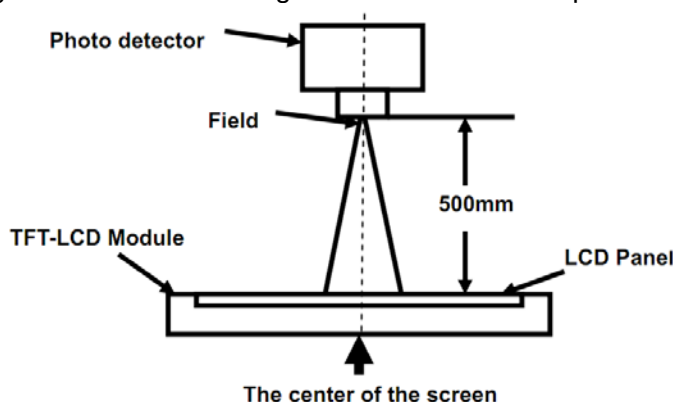

Item	Photo Detector	Field
Contrast Ratio	SR-3A	1°
Luminance		
Chromaticity		
Lum Uniformity	BM-7A	2°
Response Time		

*2. The luminance uniformity

It is calculated by using following formula.

$$\Delta Bp = Bp (\text{Min.}) / Bp (\text{Max.}) \times 100 (\%)$$

Bp (Max.) = Maximum brightness in 9 measured spots

Bp (Min.) = Minimum brightness in 9 measured spots.

Measurement equipment PR-705 (Φ8mm)

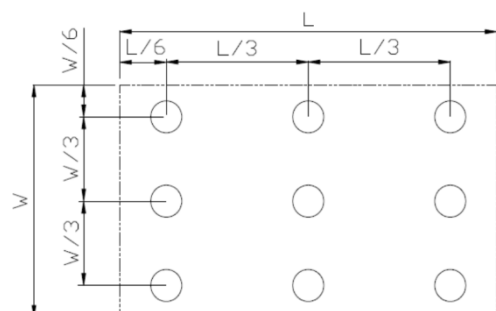

*3. The definition of viewing angle:
Refer to the graph below marked by θ and ϕ

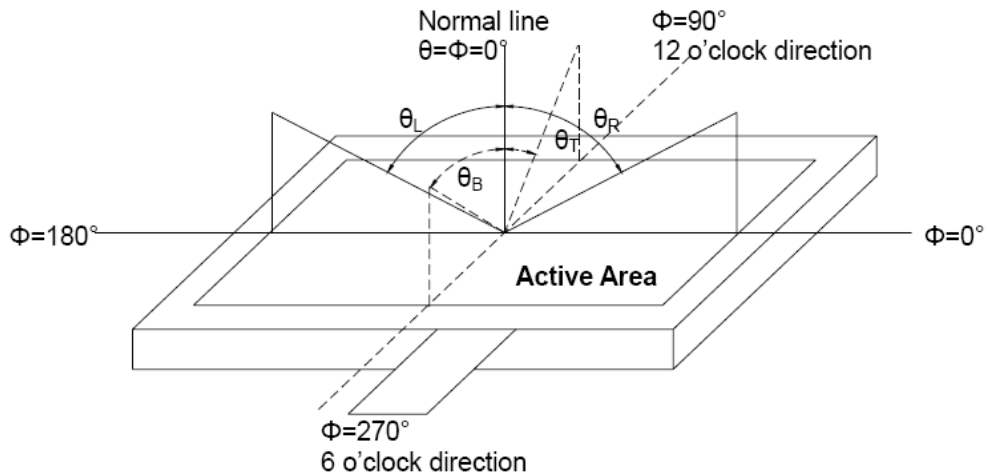

*4. The definition of contrast ratio (Test LCM using PR-705):

$$\text{Contrast Ratio(CR)} = \frac{\text{Luminance When LCD is at "White" state}}{\text{Luminance When LCD is at "Black" state}}$$

(Contrast Ratio is measured in optimum common electrode voltage)

“White state “:The state is that the LCD is driven by V_{white} .

“Black state“: The state is that the LCD is driven by V_{black} .

V_{white} : To be determined V_{black} : To be determined.

*5. Definition of Response time:

The response time is defined as the LCD optical switching time interval between “White” state and “Black” state. Rise time (T_{ON}) is the time between photo detector output intensity changed from 90% to 10%. And fall time (T_{OFF}) is the time between photo detector output intensity changed from 10% to 90%.

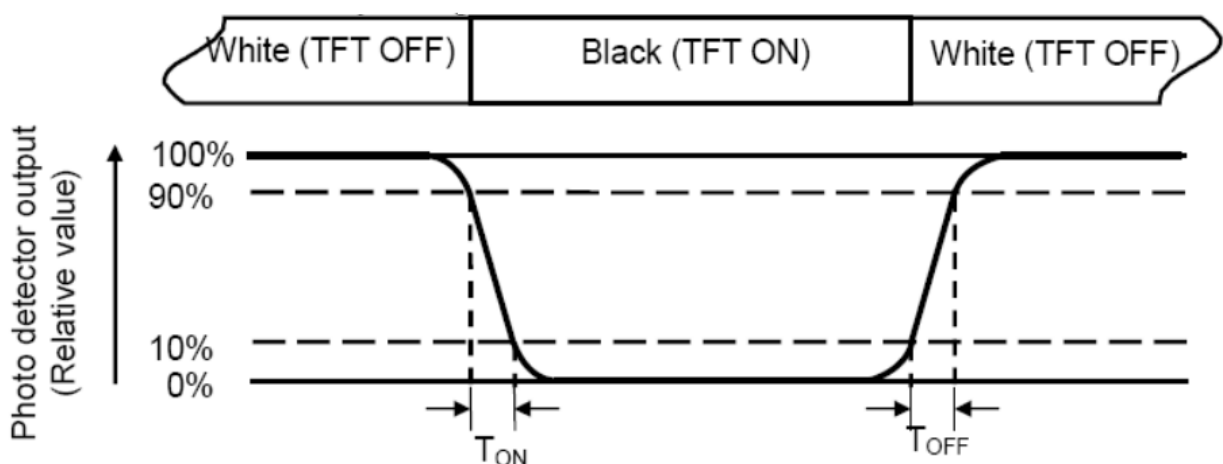

*6: Definition of Color of CIE Coordinate and NTSC Ratio.

$$S = \frac{\text{area of RGB triangle}}{\text{area of NTSC triangle}} \times 100\%$$

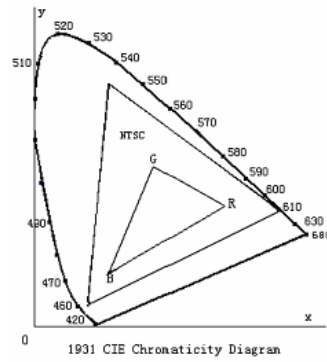

6. Design and Handling Precaution

1. The LCD panel is made by glass. Any mechanical shock (eg. dropping from high place) will damage the LCD module.
2. Do not add excessive force on the surface of the display, which may cause the Display color change abnormally.
3. The polarizer on the LCD is easily get scratched. If possible, do not remove the LCD protective film until the last step of installation.
4. Never attempt to disassemble or rework the LCD module.
5. Only Clean the LCD with Isopropyl Alcohol or Ethyl Alcohol. Other solvents (eg. water) may damage the LCD.
6. When mounting the LCD module, make sure that it is free from twisting, warping and distortion.
7. Ensure to provide enough space (with cushion) between case and LCD panel to prevent external force adding on it, or it may cause damage to the LCD or degrade the display result.
8. Only hold the LCD module by its side. Never hold LCD module by add force on the heat seal or TAB.
9. Never add force to component of the LCD module. It may cause invisible damage or degrade of the reliability.
10. LCD module could be easily damaged by static electricity. Be careful to maintain an optimum anti-static work environment to protect the LCD module.
11. When peeling off the protective film from LCD, static charge may cause abnormal display pattern. It is normal and will resume to normal in a short while.
12. Take care and prevent get hurt by the LCD panel sharp edge.
13. Never operate the LCD module exceed the absolute maximum ratings.
14. Keep the signal line as short as possible to prevent noisy signal applying to LCD module.
15. Never apply signal to the LCD module without power supply.
16. IC chip (eg. TAB or COG) is sensitive to the light. Strong lighting environment could possibly cause malfunction. Light sealing structure casing is recommend.
17. LCD module reliability may be reduced by temperature shock.
18. When storing the LCD module, avoid exposure to the direct sunlight, high humidity, high temperature or low temperature. They may damage or degrade the LCD module