



深圳市拓普微科技开发有限公司

SHENZHEN TOPWAY TECHNOLOGY CO., LTD.

# LMT032DNAFWD-NBN-2

## LCD Module User Manual

Prepared by:  <b>Zhang Yu</b>  Date: 2014-11-19	Checked by:    Date:	Approved by:    Date:
---	----------------------------------	-----------------------------------

Rev.	Descriptions	Release Date
0.1	Preliminary	2014-11-19

## Table of Content

<b>1. General Specification</b> .....	<b>3</b>
<b>2. Block Diagram</b> .....	<b>3</b>
<b>3. Terminal Functions</b> .....	<b>4</b>
3.1 Interface.....	4
<b>4. Absolute Maximum Ratings</b> .....	<b>5</b>
<b>5. Electrical Characteristics</b> .....	<b>5</b>
5.1 DC Characteristics (MCU terminal).....	5
<b>6. AC Characteristics</b> .....	<b>6</b>
6.1 AC Timing.....	6
6.2 Register Write/Read timing (for CPU 8 Bit).....	6
<b>7. Commands</b> .....	<b>7</b>
<b>8. Optical Characteristics</b> .....	<b>15</b>
<b>9. Precautions of using LCD Modules</b> .....	<b>17</b>

## 1. General Specification

Signal Interface :	8-bit MCU Interface
Display Mode :	Transmissive / normal white
Screen Size(Diagonal) :	3.2 inch
Outline Dimension :	90.0 x 58.0 x 5.9 (mm) (see attached drawing for details)
Active Area :	64.8 x 48.6 (mm)
Resolution :	320(RGB) x 240
Color Depth :	65k color(16bit)
Pixel Pitch :	0.2025 x 0.2025 (mm)
Pixel Configuration :	Horizontal RGB Stripe
Surface Treatment :	Anti-Glare Type
Viewing Direction :	9 o'clock
Backlight :	6 LEDs
Operating Temperature :	-20 ~ +70°C
Storage Temperature :	-30 ~ +80°C

Note:

\*1 Color tune may slightly changed by temperature and driving voltage.

## 2. Block Diagram

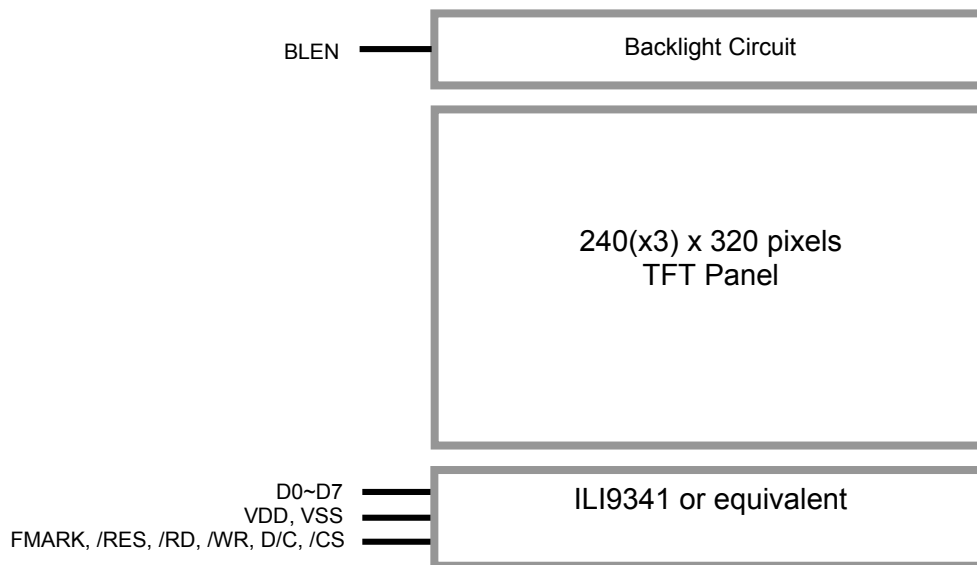

### 3. Terminal Functions

#### 3.1 Interface

Pin No.	Pin Name	I/O	Descriptions
1	VSS	P	Power Ground (0V)
2	VSS		
3	BLEN	I	BLEN=L, backlight Off BLEN=H, backlight On
4	VDD	P	Positive Power Supply
5	VDD		
6	/RD	I	/WR=H, /RD=L; Data or Status read form the LCD module
7	/WR	I	/WR=L→H, RD=H; Data or Instruction latch into the LCD module
8	D/C	I	Register Select D/C = H, Transferring the Display Data D/C = L, Transferring the Control Data
9	/CS	I	Chip Select /CS=L, enable access to the LCD interface /CS=H, disable access to the LCD interface
10	D0	I	Data Input
:	:	:	:
17	D7	I	Data Input
18	/RES	I	Reset signal /RES = L, Initialization is executed /RES = H, Normal running.
19	FMARK	O	Displaying Timing Frame Signal
20	NC	-	-

## 4. Absolute Maximum Ratings

Items	Symbol	Min.	Max.	Unit	Condition
Supply Voltage	VDD	-0.3	+4.0	V	VSS = 0V
Operating Temperature	T <sub>OP</sub>	-20	+70	°C	No Condensation
Storage Temperature	T <sub>ST</sub>	-30	+80	°C	No Condensation

### Cautions:

Any Stresses exceeding the Absolute Maximum Ratings may cause substantial damage to the device. Functional operation of this device at other conditions beyond those listed in the specification is not implied and prolonged exposure to extreme conditions may affect device reliability.

## 5. Electrical Characteristics

### 5.1 DC Characteristics (MCU terminal)

VSS=0V, T<sub>OP</sub> =25°C

Items	Symbol	MIN.	TYP.	MAX.	Unit	Applicable Pin
Operating Voltage	VDD	2.7	3.0	3.3	V	VDD
Input High Voltage	V <sub>IH</sub>	0.8VDD	-	VDD	V	Input pins
Input Low Voltage	V <sub>IL</sub>	VSS	-	0.2VDD	V	Input pins
Output Signal High Voltage	V <sub>OH</sub>	0.7VDD	-	VDD	V	
Output Signal Low Voltage	V <sub>OL</sub>	0	-	0.3VDD	V	
Operating Current	I <sub>VDD</sub>	-	94	-	mA	All black, Backlight ON (BLEN=H)
		-	8	-	mA	All black, Backlight OFF (BLEN=L)

## 6. AC Characteristics

### 6.1 AC Timing

Signal	Symbol	Parameter	Spec.			Unit	Description
			Min.	Typ	Max.		
D/C	tAST	Address setup time	10	-	-	ns	
	tAHT	Address hole time(Write/Read)	10	-	-		
/CS	tCHW	Chip select "H" pulse width	10	-	-	ns	
	tCS	Chip select setup time(Write)	56	-	-		
	tRCSFM	Chip select setup time(Read FM)	440	-	-		
	tCSF	Chip select wait time(Write/Read)	12.5	-	-		
	tCSH	Chip select hold time	12.5	-	-		
/WR	tWC	Write cycle	82.5	-	-	ns	
	tWRH	Control pulse "H" duration	18.75	-	-		
	tWRL	Control pulse "L" duration	18.75	-	-		
/RD (FM)	tRCFM	Read cycle(FM)	560	-	-	ns	When read from frame memory
	tRDHFM	Control pulse "H" duration(FM)	112	-	-		
	tRDLFM	Control pulse "L" duration(FM)	440	-	-		
D[7:0]	tDST	Data setup time	12.5	-	-	ns	For maximum CL=30pF For minimum CL=8pF
	tDHT	Data hold time	8	-	-		
	tRATFM	Read access time(FM)	-	-	425		
	tODH	Output disable time	16	-	64		

Note:

- \*1. The input signal rise time and fall time( $t_r$ ,  $t_f$ ) is specified at 15 ns or less
- \*2. Logic high and low levels are specified as 30% and 70% of VDD for input signals.
- \*3. Refer to the ILI9341 datasheet for more details.

### 6.2 Register Write/Read timing (for CPU 8 Bit)

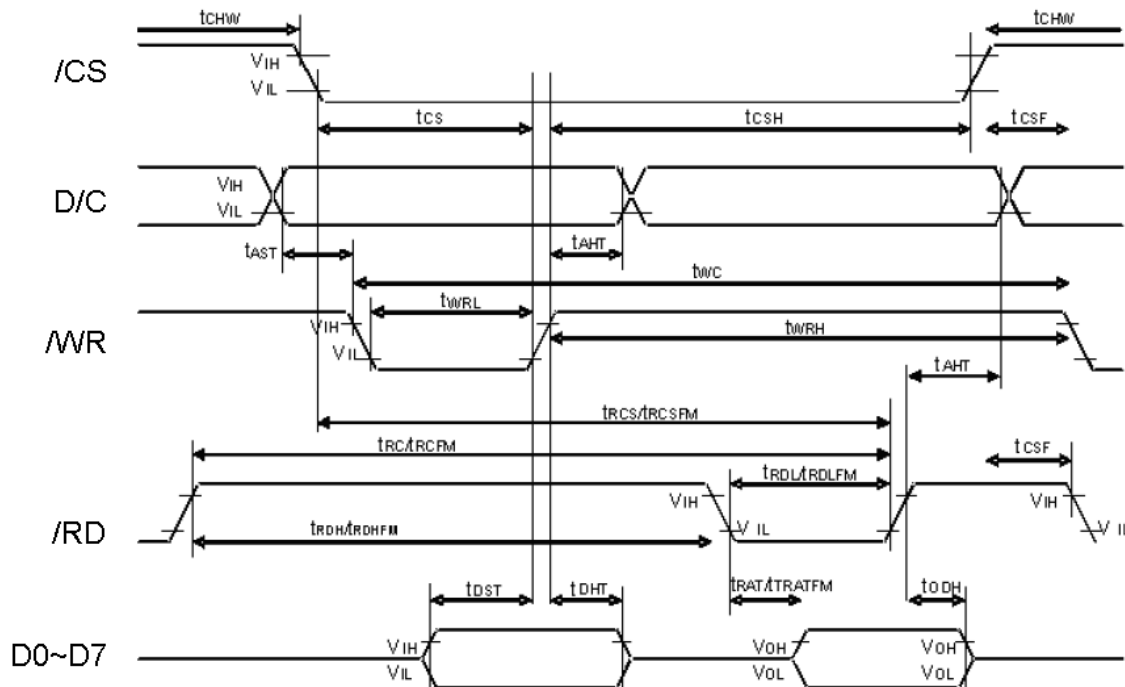

### 7. Commands

Regulative Command Set													
Command Function	D/CX	RDX	WRX	D17-8	D7	D6	D5	D4	D3	D2	D1	D0	Hex
No Operation	0	1	↑	XX	0	0	0	0	0	0	0	0	00h
Software Reset	0	1	↑	XX	0	0	0	0	0	0	0	1	01h
Read Display Identification Information	0	1	↑	XX	0	0	0	0	0	1	0	0	04h
	1	↑	1	XX	X	X	X	X	X	X	X	X	XX
	1	↑	1	XX	ID1 [7:0]							XX	
	1	↑	1	XX	ID2 [7:0]							XX	
	1	↑	1	XX	ID3 [7:0]							XX	
Read Display Status	0	1	↑	XX	0	0	0	0	1	0	0	1	09h
	1	↑	1	XX	X	X	X	X	X	X	X	X	XX
	1	↑	1	XX	D [31:25]							0	00
	1	↑	1	XX	0	D [22:20]			D [19:16]				61
	1	↑	1	XX	D [15]	0	D [13]	0	0	D [10:8]			00
	1	↑	1	XX	D [7:5]			D [4:1]			0	00	
Read Display Power Mode	0	1	↑	XX	0	0	0	0	1	0	1	0	0Ah
	1	↑	1	XX	X	X	X	X	X	X	X	X	XX
	1	↑	1	XX	D [7:2]						0	0	08
Read Display MADCTL	0	1	↑	XX	0	0	0	0	1	0	1	1	0Bh
	1	↑	1	XX	X	X	X	X	X	X	X	X	XX
	1	↑	1	XX	D [7:2]						0	0	00
Read Display Pixel Format	0	1	↑	XX	0	0	0	0	1	1	0	0	0Ch
	1	↑	1	XX	X	X	X	X	X	X	X	X	XX
	1	↑	1	XX	0	DPI [2:0]			0	DBI [2:0]			06
Read Display Image Format	0	1	↑	XX	0	0	0	0	1	1	0	1	0Dh
	1	↑	1	XX	X	X	X	X	X	X	X	X	XX
	1	↑	1	XX	0	0	0	0	0	D [2:0]			00
Read Display Signal Mode	0	1	↑	XX	0	0	0	0	1	1	1	0	0Eh
	1	↑	1	XX	X	X	X	X	X	X	X	X	XX
	1	↑	1	XX	D [7:2]						0	0	00
Read Display Self-Diagnostic Result	0	1	↑	XX	0	0	0	0	1	1	1	1	0Fh
	1	↑	1	XX	X	X	X	X	X	X	X	X	XX
	1	↑	1	XX	D [7:6]						0	0	00
Enter Sleep Mode	0	1	↑	XX	0	0	0	1	0	0	0	0	10h
Sleep OUT	0	1	↑	XX	0	0	0	1	0	0	0	1	11h
Partial Mode ON	0	1	↑	XX	0	0	0	1	0	0	1	0	12h
Normal Display Mode ON	0	1	↑	XX	0	0	0	1	0	0	1	1	13h
Display Inversion OFF	0	1	↑	XX	0	0	1	0	0	0	0	0	20h
Display Inversion ON	0	1	↑	XX	0	0	1	0	0	0	0	1	21h
Gamma Set	0	1	↑	XX	0	0	1	0	0	1	1	0	26h
	1	1	↑	XX	GC [7:0]							01	
Display OFF	0	1	↑	XX	0	0	1	0	1	0	0	0	28h
Display ON	0	1	↑	XX	0	0	1	0	1	0	0	1	29h
Column Address Set	0	1	↑	XX	0	0	1	0	1	0	1	0	2Ah
	1	1	↑	XX	SC [15:8]							XX	
	1	1	↑	XX	SC [7:0]							XX	
	1	1	↑	XX	EC [15:8]							XX	
	1	1	↑	XX	EC [7:0]							XX	
Page Address Set	0	1	↑	XX	0	0	1	0	1	0	1	1	2Bh
	1	1	↑	XX	SP [15:8]							XX	
	1	1	↑	XX	SP [7:0]							XX	
	1	1	↑	XX	EP [15:8]							XX	
	1	1	↑	XX	EP [7:0]							XX	

Commands(continue)

Memory Write	0	1	↑	XX	0	0	1	0	1	1	0	0	2Ch
	1	1	↑		D [17:0]								XX
Color SET	0	1	↑	XX	0	0	1	0	1	1	0	1	2Dh
	1	1	↑	XX	0	0	R00 [5:0]						XX
	1	1	↑	XX	0	0	Rnn [5:0]						XX
	1	1	↑	XX	0	0	R31 [5:0]						XX
	1	1	↑	XX	0	0	G00 [5:0]						XX
	1	1	↑	XX	0	0	Gnn [5:0]						XX
	1	1	↑	XX	0	0	G64 [5:0]						XX
	1	1	↑	XX	0	0	B00 [5:0]						XX
	1	1	↑	XX	0	0	Bnn [5:0]						XX
	1	1	↑	XX	0	0	B31 [5:0]						XX
	Memory Read	0	1	↑	XX	0	0	1	0	1	1	1	0
1		↑	1	XX	X	X	X	X	X	X	X	X	XX
1		↑	1		D [17:0]								XX
Partial Area	0	1	↑	XX	0	0	1	1	0	0	0	0	30h
	1	1	↑	XX	SR [15:8]								00
	1	1	↑	XX	SR [7:0]								00
	1	1	↑	XX	ER [15:8]								01
	1	1	↑	XX	ER [7:0]								3F
Vertical Scrolling Definition	0	1	↑	XX	0	0	1	1	0	0	1	1	33h
	1	1	↑	XX	TFA [15:8]								00
	1	1	↑	XX	TFA [7:0]								00
	1	1	↑	XX	VSA [15:8]								01
	1	1	↑	XX	VSA [7:0]								40
	1	1	↑	XX	BFA [15:8]								00
Tearing Effect Line OFF	0	1	↑	XX	0	0	1	1	0	1	0	0	34h
	0	1	↑	XX	0	0	1	1	0	1	0	1	35h
Tearing Effect Line ON	1	1	↑	XX	0	0	0	0	0	0	0	M	00
	0	1	↑	XX	0	0	1	1	0	1	1	0	36h
Memory Access Control	1	1	↑	XX	MY	MX	MV	ML	BGR	MH	0	0	00
	0	1	↑	XX	0	0	1	1	0	1	1	1	37h
Vertical Scrolling Start Address	1	1	↑	XX	VSP [15:8]								00
	1	1	↑	XX	VSP [7:0]								00
Idle Mode OFF	0	1	↑	XX	0	0	1	1	1	0	0	0	38h
Idle Mode ON	0	1	↑	XX	0	0	1	1	1	0	0	1	39h
Pixel Format Set	0	1	↑	XX	0	0	1	1	1	0	1	0	3Ah
	1	1	↑	XX	0	DPI [2:0]			0	DBI [2:0]			66
Write Memory Continue	0	1	↑	XX	0	0	1	1	1	1	0	0	3Ch
	1	1	↑		D [17:0]								XX
Read Memory Continue	0	1	↑	XX	0	0	1	1	1	1	1	0	3Eh
	1	↑	1	XX	X	X	X	X	X	X	X	X	XX
	1	↑	1		D [17:0]								XX
Set Tear Scanline	0	1	↑	XX	0	1	0	0	0	1	0	0	44h
	1	1	↑	XX	0	0	0	0	0	0	0	STS [8]	XX
	1	1	↑	XX	STS [7:0]								XX
Get Scanline	0	1	↑	XX	0	1	0	0	0	1	0	1	45h
	1	↑	1	XX	X	X	X	X	X	X	X	X	XX
	1	↑	1	XX	0	0	0	0	0	0	GTS [9:8]		XX
	1	↑	1	XX	GTS [7:0]								XX
Write Display Brightness	0	1	↑	XX	0	1	0	1	0	0	0	1	51h
	1	1	↑	XX	DBV [7:0]								00



Commands(continue)

Read Display Brightness	0	1	↑	XX	0	1	0	1	0	0	1	0	52h
	1	↑	1	XX	X	X	X	X	X	X	X	X	XX
	1	↑	1	XX	DBV [7:0]								00
Write CTRL Display	0	1	↑	XX	0	1	0	1	0	0	1	1	53h
	1	1	↑	XX	0	0	BCTRL	0	DD	BL	0	0	00
Read CTRL Display	0	1	↑	XX	0	1	0	1	0	1	0	0	54h
	1	↑	1	XX	X	X	X	X	X	X	X	X	XX
	1	↑	1	XX	0	0	BCTRL	0	DD	BL	0	0	00
Write Content Adaptive Brightness Control	0	1	↑	XX	0	1	0	1	0	1	0	1	55h
	1	1	↑	XX	0	0	0	0	0	0	C [1:0]		00
Read Content Adaptive Brightness Control	0	1	↑	XX	0	1	0	1	0	1	1	0	56h
	1	↑	1	XX	X	X	X	X	X	X	X	X	XX
	1	↑	1	XX	0	0	0	0	0	0	C [1:0]		00
Write CAB Minimum Brightness	0	1	↑	XX	0	1	0	1	1	1	1	0	5Eh
	1	1	↑	XX	CMB [7:0]								00
Read CAB Minimum Brightness	0	1	↑	XX	0	1	0	1	1	1	1	1	5Fh
	1	↑	1	XX	X	X	X	X	X	X	X	X	XX
	1	↑	1	XX	CMB [7:0]								00
Read ID1	0	1	↑	XX	1	1	0	1	1	0	1	0	DAh
	1	↑	1	XX	X	X	X	X	X	X	X	X	XX
	1	↑	1	XX	Module's Manufacture [7:0]								XX
Read ID2	0	1	↑	XX	1	1	0	1	1	0	1	1	DBh
	1	↑	1	XX	X	X	X	X	X	X	X	X	XX
	1	↑	1	XX	LCD Module / Driver Version [7:0]								XX
Read ID3	0	1	↑	XX	1	1	0	1	1	1	0	0	DCh
	1	↑	1	XX	X	X	X	X	X	X	X	X	XX
	1	↑	1	XX	LCD Module / Driver ID [7:0]								XX

Extended Command Set													
Command Function	D/CX	RDX	WRX	D17-8	D7	D6	D5	D4	D3	D2	D1	D0	Hex
RGB Interface Signal Control	0	1	↑	XX	1	0	1	1	0	0	0	0	B0h
	1	1	↑	XX	ByPass_MODE	RCM [1:0]		0	VSPL	HSPL	DPL	EPL	00
Frame Control (In Normal Mode)	0	1	↑	XX	1	0	1	1	0	0	0	1	B1h
	1	1	↑	XX	0	0	0	0	0	0	DIVA [1:0]		00
	1	1	↑	XX	0	0	0	RTNA [4:0]				1B	
Frame Control (In Idle Mode)	0	1	↑	XX	1	0	1	1	0	0	1	0	B2h
	1	1	↑	XX	0	0	0	0	0	0	DIVB [1:0]		00
	1	1	↑	XX	0	0	0	RTNB [4:0]				1B	
Frame Control (In Partial Mode)	0	1	↑	XX	1	0	1	1	0	0	1	1	B3h
	1	1	↑	XX	0	0	0	0	0	0	DIVC [1:0]		00
	1	1	↑	XX	0	0	0	RTNC [4:0]				1B	
Display Inversion Control	0	1	↑	XX	1	0	1	1	0	1	0	0	B4h
	1	1	↑	XX	0	0	0	0	0	NLA	NLB	NLC	02
Blanking Porch Control	0	1	↑	XX	1	0	1	1	0	1	0	1	B5h
	1	1	↑	XX	0	VFP [6:0]						02	
	1	1	↑	XX	0	VBP [6:0]						02	
	1	1	↑	XX	0	0	0	HFP [4:0]				0A	
	1	1	↑	XX	0	0	0	HBP [4:0]				14	

Commands(continue)

Display Function Control	0	1	↑	XX	1	0	1	1	0	1	1	0	B6h	
	1	1	↑	XX	0	0	0	0	PTG [1:0]		PT [1:0]		0A	
	1	1	↑	XX	REV	GS	SS	SM	ISC [3:0]				82	
	1	1	↑	XX	0	0	NL [5:0]						27	
	1	1	↑	XX	0	0	PCDIV [5:0]						04	
Entry Mode Set	0	1	↑	XX	1	0	1	1	0	1	1	1	B7h	
	1	1	↑	XX	0	0	0	0	0	GON	DTE	GAS	06	
Backlight Control 1	0	1	↑	XX	1	0	1	1	1	0	0	0	B8h	
	1	1	↑	XX	0	0	0	0	TH_UI [3:0]				0C	
Backlight Control 2	0	1	↑	XX	1	0	1	1	1	0	0	1	B9h	
	1	1	↑	XX	TH_MV [3:0]			TH_ST [3:0]				CC		
Backlight Control 3	0	1	↑	XX	1	0	1	1	1	0	1	0	BAh	
	1	1	↑	XX	0	0	0	0	DTH_UI [3:0]				04	
Backlight Control 4	0	1	↑	XX	1	0	1	1	1	0	1	1	BBh	
	1	1	↑	XX	DTH_MV [3:0]			DTH_ST [3:0]				65		
Backlight Control 5	0	1	↑	XX	1	0	1	1	1	1	0	0	BCh	
	1	1	↑	XX	DIM2 [3:0]			0	DIM1 [2:0]			44		
Backlight Control 7	0	1	↑	XX	1	0	1	1	1	1	1	0	BEh	
	1	1	↑	XX	PWM_DIV [7:0]							0F		
Backlight Control 8	0	1	↑	XX	1	0	1	1	1	1	1	1	BFh	
	1	1	↑	XX	0	0	0	0	0	LEDONR	LEDONPOL	LEDPWMOPL	00	
Power Control 1	0	1	↑	XX	1	1	0	0	0	0	0	0	C0h	
	1	1	↑	XX	0	0	VRH [5:0]					21		
Power Control 2	0	1	↑	XX	1	1	0	0	0	0	0	1	C1h	
	1	1	↑	XX	0	0	0	1	0	BT [2:0]			10	
VCOM Control 1	0	1	↑	XX	1	1	0	0	0	1	0	1	C5h	
	1	1	↑	XX	0	VMH [6:0]						31		
	1	1	↑	XX	0	VML [6:0]						3C		
VCOM Control 2	0	1	↑	XX	1	1	0	0	0	1	1	1	C7h	
	1	1	↑	XX	nVM	VMF [6:0]						C0		
NV Memory Write	0	1	↑	XX	1	1	0	1	0	0	0	0	D0h	
	1	1	↑	XX	0	0	0	0	0	PGM_ADR [2:0]			00	
	1	1	↑	XX	PGM_DATA [7:0]							XX		
NV Memory Protection Key	0	1	↑	XX	1	1	0	1	0	0	0	1	D1h	
	1	1	↑	XX	KEY [23:16]							XX		
	1	1	↑	XX	KEY [15:8]							XX		
	1	1	↑	XX	KEY [7:0]							XX		
NV Memory Status Read	0	1	↑	XX	1	1	0	1	0	0	1	0	D2h	
	1	↑	1	XX	X	X	X	X	X	X	X	X	XX	
	1	↑	1	XX	0	ID2_CNT [2:0]			0	ID1_CNT [2:0]			XX	
	1	↑	1	XX	BUSY	VMF_CNT [2:0]			0	ID3_CNT [2:0]			XX	

Commands(continue)

Read ID4	0	1	↑	XX	1	1	0	1	0	0	1	1	D3h
	1	↑	1	XX	X	X	X	X	X	X	X	X	XX
	1	↑	1	XX	0	0	0	0	0	0	0	0	00
	1	↑	1	XX	1	0	0	1	0	0	1	1	93
	1	↑	1	XX	0	1	0	0	0	0	0	1	41
Positive Gamma Correction	0	1	↑	XX	1	1	1	0	0	0	0	0	E0h
	1	1	↑	XX	0	0	0	0	VP0 [3:0]			0F	
	1	1	↑	XX	0	0	VP1 [5:0]					16	
	1	1	↑	XX	0	0	VP2 [5:0]					14	
	1	1	↑	XX	0	0	0	0	VP4 [3:0]			0A	
	1	1	↑	XX	0	0	VP6 [4:0]				0D		
	1	1	↑	XX	0	0	0	0	VP13 [3:0]			06	
	1	1	↑	XX	0	VP20 [6:0]						43	
	1	1	↑	XX	VP36 [3:0]			VP27 [3:0]			75		
	1	1	↑	XX	0	VP43 [6:0]						33	
	1	1	↑	XX	0	0	0	0	VP50 [3:0]			06	
	1	1	↑	XX	0	0	VP57 [4:0]				0E		
	1	1	↑	XX	0	0	0	0	VP59 [3:0]			00	
	1	1	↑	XX	0	0	VP61 [5:0]					0C	
	1	1	↑	XX	0	0	VP62 [5:0]					09	
1	1	↑	XX	0	0	0	0	VP63 [3:0]			08		
Negative Gamma Correction	0	1	↑	XX	1	1	1	0	0	0	0	1	E1h
	1	1	↑	XX	0	0	0	0	VN0 [3:0]			08	
	1	1	↑	XX	0	0	VN1 [5:0]					2B	
	1	1	↑	XX	0	0	VN2 [5:0]					2D	
	1	1	↑	XX	0	0	0	0	VN4 [3:0]			04	
	1	1	↑	XX	0	0	VN6 [4:0]				10		
	1	1	↑	XX	0	0	0	0	VN13 [3:0]			04	
	1	1	↑	XX	0	VN20 [6:0]						3E	
	1	1	↑	XX	VN36 [3:0]			VN27 [3:0]			24		
	1	1	↑	XX	0	VN43 [6:0]						4E	
	1	1	↑	XX	0	0	0	0	VN50 [3:0]			04	
	1	1	↑	XX	0	0	VN57 [4:0]				0F		
	1	1	↑	XX	0	0	0	0	VN59 [3:0]			0E	
	1	1	↑	XX	0	0	VN61 [5:0]					35	
	1	1	↑	XX	0	0	VN62 [5:0]					38	
1	1	↑	XX	0	0	0	0	VN63 [3:0]			0F		
Digital Gamma Control 1	0	1	↑	XX	1	1	1	0	0	0	1	0	E2h
1 <sup>st</sup> Parameter	1	1	↑	XX	RCA0 [3:0]				BCA0 [3:0]				XX
2 <sup>nd</sup> Parameter	1	1	↑	XX	RCA1 [3:0]				BCA1 [3:0]				XX
3 <sup>rd</sup> Parameter	1	1	↑	XX	RCA2 [3:0]				BCA2 [3:0]				XX
4 <sup>th</sup> Parameter	1	1	↑	XX	RCA3 [3:0]				BCA3 [3:0]				XX
5 <sup>th</sup> Parameter	1	1	↑	XX	RCA4 [3:0]				BCA4 [3:0]				XX
6 <sup>th</sup> Parameter	1	1	↑	XX	RCA5 [3:0]				BCA5 [3:0]				XX
7 <sup>th</sup> Parameter	1	1	↑	XX	RCA6 [3:0]				BCA6 [3:0]				XX
8 <sup>th</sup> Parameter	1	1	↑	XX	RCA7 [3:0]				BCA7 [3:0]				XX
9 <sup>th</sup> Parameter	1	1	↑	XX	RCA8 [3:0]				BCA8 [3:0]				XX
10 <sup>th</sup> Parameter	1	1	↑	XX	RCA9 [3:0]				BCA9 [3:0]				XX
11 <sup>th</sup> Parameter	1	1	↑	XX	RCA10 [3:0]				BCA10 [3:0]				XX
12 <sup>th</sup> Parameter	1	1	↑	XX	RCA11 [3:0]				BCA11 [3:0]				XX
13 <sup>th</sup> Parameter	1	1	↑	XX	RCA12 [3:0]				BCA12 [3:0]				XX
14 <sup>th</sup> Parameter	1	1	↑	XX	RCA13 [3:0]				BCA13 [3:0]				XX
15 <sup>th</sup> Parameter	1	1	↑	XX	RCA14 [3:0]				BCA14 [3:0]				XX
16 <sup>th</sup> Parameter	1	1	↑	XX	RCA15 [3:0]				BCA15 [3:0]				XX

## Commands(continue)

Digital Gamma Control 2	0	1	↑	XX	1	1	1	0	0	0	1	1	E3h
1 <sup>st</sup> Parameter	1	1	↑	XX	RFA0 [3:0]				BFA0 [3:0]				XX
2 <sup>nd</sup> Parameter	1	1	↑	XX	RFA1 [3:0]				BFA1 [3:0]				XX
3 <sup>rd</sup> Parameter	1	1	↑	XX	RFA2 [3:0]				BFA2 [3:0]				XX
4 <sup>th</sup> Parameter	1	1	↑	XX	RFA3 [3:0]				BFA3 [3:0]				XX
5 <sup>th</sup> Parameter	1	1	↑	XX	RFA4 [3:0]				BFA4 [3:0]				XX
6 <sup>th</sup> Parameter	1	1	↑	XX	RFA5 [3:0]				BFA5 [3:0]				XX
7 <sup>th</sup> Parameter	1	1	↑	XX	RFA6 [3:0]				BFA6 [3:0]				XX
8 <sup>th</sup> Parameter	1	1	↑	XX	RFA7 [3:0]				BFA7 [3:0]				XX
9 <sup>th</sup> Parameter	1	1	↑	XX	RFA8 [3:0]				BFA8 [3:0]				XX
10 <sup>th</sup> Parameter	1	1	↑	XX	RFA9 [3:0]				BFA9 [3:0]				XX
11 <sup>th</sup> Parameter	1	1	↑	XX	RFA10 [3:0]				BFA10 [3:0]				XX
12 <sup>th</sup> Parameter	1	1	↑	XX	RFA11 [3:0]				BFA [3:0]				XX
13 <sup>th</sup> Parameter	1	1	↑	XX	RFA12 [3:0]				BFA12 [3:0]				XX
14 <sup>th</sup> Parameter	1	1	↑	XX	RFA13 [3:0]				BFA13 [3:0]				XX
15 <sup>th</sup> Parameter	1	1	↑	XX	RFA14 [3:0]				BFA14 [3:0]				XX
16 <sup>th</sup> Parameter	1	1	↑	XX	RFA15 [3:0]				BFA15 [3:0]				XX
17 <sup>th</sup> Parameter	1	1	↑	XX	RFA16 [3:0]				BFA16 [3:0]				XX
18 <sup>th</sup> Parameter	1	1	↑	XX	RFA17 [3:0]				BFA17 [3:0]				XX
19 <sup>th</sup> Parameter	1	1	↑	XX	RFA18 [3:0]				BFA18 [3:0]				XX
20 <sup>th</sup> Parameter	1	1	↑	XX	RFA19 [3:0]				BFA19 [3:0]				XX
21 <sup>st</sup> Parameter	1	1	↑	XX	RFA20 [3:0]				BFA20 [3:0]				XX
22 <sup>nd</sup> Parameter	1	1	↑	XX	RFA21 [3:0]				BFA21 [3:0]				XX
23 <sup>rd</sup> Parameter	1	1	↑	XX	RFA22 [3:0]				BFA22 [3:0]				XX
24 <sup>th</sup> Parameter	1	1	↑	XX	RFA23 [3:0]				BFA23 [3:0]				XX
25 <sup>th</sup> Parameter	1	1	↑	XX	RFA24 [3:0]				BFA24 [3:0]				XX
26 <sup>th</sup> Parameter	1	1	↑	XX	RFA25 [3:0]				BFA25 [3:0]				XX
27 <sup>th</sup> Parameter	1	1	↑	XX	RFA26 [3:0]				BFA26 [3:0]				XX
28 <sup>th</sup> Parameter	1	1	↑	XX	RFA27 [3:0]				BFA27 [3:0]				XX
29 <sup>th</sup> Parameter	1	1	↑	XX	RFA28 [3:0]				BFA28 [3:0]				XX
30 <sup>th</sup> Parameter	1	1	↑	XX	RFA29 [3:0]				BFA29 [3:0]				XX
31 <sup>st</sup> Parameter	1	1	↑	XX	RFA30 [3:0]				BFA30 [3:0]				XX
32 <sup>nd</sup> Parameter	1	1	↑	XX	RFA31 [3:0]				BFA31 [3:0]				XX
33 <sup>rd</sup> Parameter	1	1	↑	XX	RFA32 [3:0]				BFA32 [3:0]				XX
34 <sup>th</sup> Parameter	1	1	↑	XX	RFA33 [3:0]				BFA33 [3:0]				XX
35 <sup>th</sup> Parameter	1	1	↑	XX	RFA34 [3:0]				BFA34 [3:0]				XX
36 <sup>th</sup> Parameter	1	1	↑	XX	RFA35 [3:0]				BFA35 [3:0]				XX
37 <sup>th</sup> Parameter	1	1	↑	XX	RFA36 [3:0]				BFA36 [3:0]				XX
38 <sup>th</sup> Parameter	1	1	↑	XX	RFA37 [3:0]				BFA37 [3:0]				XX

39 <sup>th</sup> Parameter	1	1	↑	XX	RFA38 [3:0]				BFA38 [3:0]				XX
40 <sup>th</sup> Parameter	1	1	↑	XX	RFA39 [3:0]				BFA39 [3:0]				XX
41 <sup>st</sup> Parameter	1	1	↑	XX	RFA40 [3:0]				BFA40 [3:0]				XX
42 <sup>nd</sup> Parameter	1	1	↑	XX	RFA41 [3:0]				BFA41 [3:0]				XX
43 <sup>rd</sup> Parameter	1	1	↑	XX	RFA42 [3:0]				BFA42 [3:0]				XX
44 <sup>th</sup> Parameter	1	1	↑	XX	RFA43 [3:0]				BFA43 [3:0]				XX
45 <sup>th</sup> Parameter	1	1	↑	XX	RFA44 [3:0]				BFA44 [3:0]				XX
46 <sup>th</sup> Parameter	1	1	↑	XX	RFA45 [3:0]				BFA45 [3:0]				XX
47 <sup>th</sup> Parameter	1	1	↑	XX	RFA46 [3:0]				BFA46 [3:0]				XX
48 <sup>th</sup> Parameter	1	1	↑	XX	RFA47 [3:0]				BFA47 [3:0]				XX
49 <sup>th</sup> Parameter	1	1	↑	XX	RFA48 [3:0]				BFA48 [3:0]				XX
50 <sup>th</sup> Parameter	1	1	↑	XX	RFA49 [3:0]				BFA49 [3:0]				XX
51 <sup>st</sup> Parameter	1	1	↑	XX	RFA50 [3:0]				BFA50 [3:0]				XX
52 <sup>nd</sup> Parameter	1	1	↑	XX	RFA51 [3:0]				BFA51 [3:0]				XX
53 <sup>rd</sup> Parameter	1	1	↑	XX	RFA52 [3:0]				BFA52 [3:0]				XX
54 <sup>th</sup> Parameter	1	1	↑	XX	RFA53 [3:0]				BFA53 [3:0]				XX
55 <sup>th</sup> Parameter	1	1	↑	XX	RFA54 [3:0]				BFA54 [3:0]				XX
56 <sup>th</sup> Parameter	1	1	↑	XX	RFA55 [3:0]				BFA55 [3:0]				XX
57 <sup>th</sup> Parameter	1	1	↑	XX	RFA56 [3:0]				BFA56 [3:0]				XX
58 <sup>th</sup> Parameter	1	1	↑	XX	RFA57 [3:0]				BFA57 [3:0]				XX
59 <sup>th</sup> Parameter	1	1	↑	XX	RFA58 [3:0]				BFA58 [3:0]				XX
60 <sup>th</sup> Parameter	1	1	↑	XX	RFA59 [3:0]				BFA59 [3:0]				XX
61 <sup>st</sup> Parameter	1	1	↑	XX	RFA60 [3:0]				BFA60 [3:0]				XX
62 <sup>nd</sup> Parameter	1	1	↑	XX	RFA61 [3:0]				BFA61 [3:0]				XX
63 <sup>rd</sup> Parameter	1	1	↑	XX	RFA62 [3:0]				BFA62 [3:0]				XX
64 <sup>th</sup> Parameter	1	1	↑	XX	RFA63 [3:0]				BFA63 [3:0]				XX
Interface Control	0	1	↑	XX	1	1	1	1	0	1	1	0	F6h
	1	1	↑	XX	MY_EOR	MX_EOR	MV_EOR	0	BGR_EOR	0	0	WEMODE	01
	1	1	↑	XX	0	0	EPF [1:0]		0	0	MDT [1:0]		00
	1	1	↑	XX	0	0	ENDIAN	0	DM [1:0]		RM	RIM	00
Power Control A	0	1	↑	XX	1	1	0	0	1	0	1	1	CBh
	1	1	↑	XX	0	0	1	1	1	0	0	1	39
	1	1	↑	XX	0	0	1	0	1	1	0	0	2C
	1	1	↑	XX	0	0	0	0	0	0	0	0	00
	1	1	↑	XX	0	0	1	1	0	REG_VD[2:0]			30
1	1	↑	XX	0	0	0	0	0	VBC[2:0]			01	
Power Control B	0	1	↑	XX	1	1	0	0	1	1	1	1	CFh
	1	1	↑	XX	0	0	0	0	0	0	0	0	00
	1	1	↑	XX	1	PCEQ	DRV_ena	Power control[1:0]		0	0	1	81
1	1	↑	XX	DRV_vml[2:1]		1	DC_ena	DRV_vml[0]	DRV_vmh[2:0]			30	
Driver timing control A	0	1	↑	XX	1	1	1	0	1	0	0	0	E8h
	1	1	↑	XX	CR/EQ/PC	SDT[1:0]		0	0	1	0	NOW	84
	1	1	↑	XX	0	0	EQ[2:0]		CR[2:0]				11

Driver timing control B	1	1	↑	XX	0	1	1	1	1	PC[1:0]			7A
	0	1	↑	XX	1	1	1	0	1	0	0	1	E9h
	1	1	↑	XX	CRE/EQE /PCE	SDT[1:0]		0	0	1	0	NOWE	04
	1	1	↑	XX	0	0	EQ[2:0]		CR[2:0]			11	
	1	1	↑	XX	0	1	1	1	1	PC[1:0]			7A
Driver timing control C	0	1	↑	XX	1	1	1	0	1	0	1	0	EAh
	1	1	↑	XX	VG_SW_T4		VG_SW_T3		VG_SW_T2		VG_SW_T1		66
	1	1	↑	XX	1	1	1	0	1	1	0	1	EDh
Power on sequence control	1	1	↑	XX	0	1	CP1 soft start		0	1	CP23 soft start		55
	1	1	↑	XX	0	0	En_vcl		0	0	En_ddvdh		01
	1	1	↑	XX	0	0	En_vgh		0	0	En_vgl		23
	1	1	↑	XX	DDVDH_ENH		0	0	0	0	0	1	01
	0	1	↑	XX	1	1	1	1	0	0	1	0	F2h
Enable 3G	1	1	↑	XX	0	0	0	0	0	0	1	3G_enb	02

Note:

Please refer to ILI9341 data sheet for details

## 8. Optical Characteristics

Item	Symbol	Condition	MIN.	TYP.	MAX.	UNIT	Note.	
Brightness	Bp	$\theta = 0^\circ$	-	-	-	Cd/m <sup>2</sup>	Note 1	
Uniformity	$\Delta Bp$	$\Phi = 0^\circ$	80%	-	-	-	Note 1,2	
Viewing Angle	$\theta = 0^\circ$	Cr $\geq$ 10	-	45	-	Deg	Note 3	
	$\theta = 90^\circ$		-	45	-			
	$\theta = 180^\circ$		-	20	-			
	$\theta = 270^\circ$		-	45	-			
Contrast ratio	CR	$\theta = 0^\circ$	-	500	-	-	Note 4	
Response Time	T <sub>on</sub>	$\Phi = 0^\circ$ 25°C	-	25	40	msec	Note 5	
	T <sub>off</sub>		-	-	-	msec		
Color of CIE Coordinate	White	X	$\theta = 0^\circ$ $\Phi = 0^\circ$	0.255	0.305	0.355	-	Note 1,6
		Y		0.275	0.325	0.375	-	
	Red	X		0.576	0.626	0.676	-	
		Y		0.284	0.334	0.384	-	
	Green	X		0.227	0.277	0.327	-	
		Y		0.499	0.549	0.599	-	
	Blue	X		0.092	0.142	0.192	-	
		Y		0.072	0.122	0.172	-	
NTSC Ratio	S	-	60%	-	-	-		

Note: The parameter is slightly changed by temperature, driving voltage and materiel.

Note 1:

The data are measured after LEDs are turned on for 5 minutes. LCM displays full white.

The brightness is the average value of 9 measured spots.

Measurement equipment PR-705 (Φ8mm)

Measuring condition:

- Measuring surroundings: Dark room
- Measuring temperature: Ta=25°C.
- Adjust operating voltage to get optimum contrast at the center of the display.

Measured value at the center point of LCD panel after more than 5 minutes while backlight turning on.

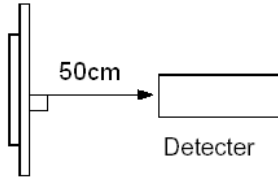

Note 3:

The definition of viewing angle:

Refer to the graph below marked by  $\theta$  and  $\phi$

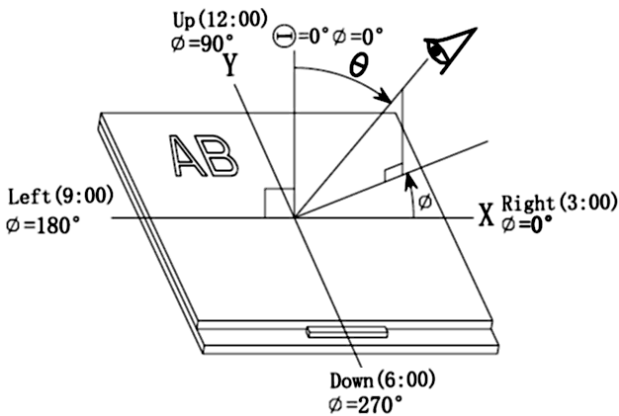

Note 5:

Definition of Response time. (Test LCD using DMS501):

The output signals of photo detector are measured when the input signals are changed from "black" to "white"(falling time) and from "white" to "black"(rising time), respectively.

The response time is defined as the time interval between the 10% and 90% of amplitudes. Refer to figure as below.

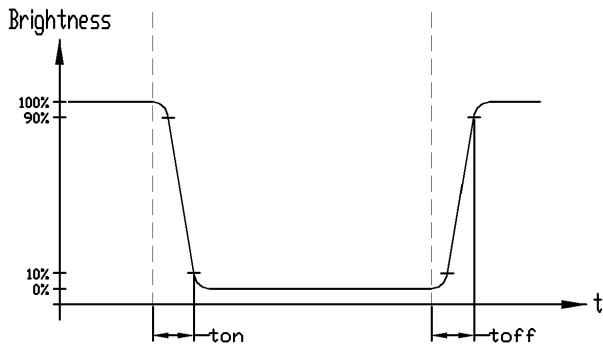

Note 2:

The luminance uniformity is calculated by using following formula.

$$\Delta B_p = B_p (\text{Min.}) / B_p (\text{Max.}) \times 100 (\%)$$

$B_p (\text{Max.})$  = Maximum brightness in 9 measured spots

$B_p (\text{Min.})$  = Minimum brightness in 9 measured spots.

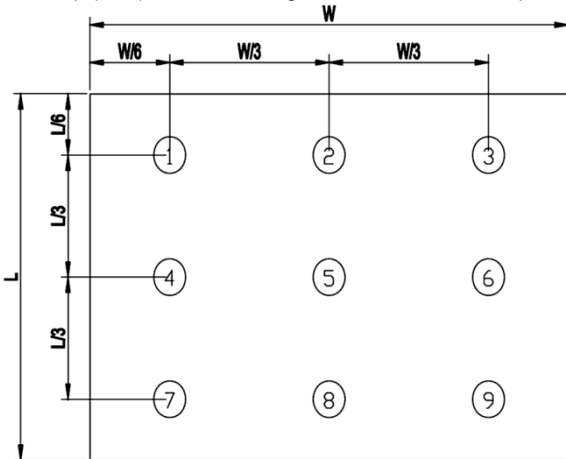

Note 4:

The definition of contrast ratio (Test LCM using PR-705):

$$\text{Contrast Ratio (CR)} = \frac{\text{Luminance When LCD is at "White" state}}{\text{Luminance When LCD is at "Black" state}}$$

(Contrast Ratio is measured in optimum common electrode voltage)

Note 6:

Definition of Color of CIE1931 Coordinate and NTSC Ratio.

Color gamut:

$$S = \frac{\text{Area of RGB triangle}}{\text{Area of NTSC triangle}} \times 100\%$$

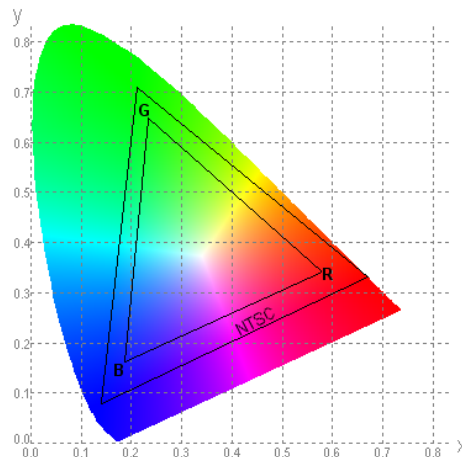



## 9. Precautions of using LCD Modules

### Mounting

- Mounting must use holes arranged in four corners or four sides.
- The mounting structure so provide even force on to LCD module. Uneven force (ex. Twisted stress) should not applied to the module. And the case on which a module is mounted should have sufficient strength so that external force is not transmitted directly to the module.
- It is suggested to attach a transparent protective plate to the surface in order to protect the polarizer. It should have sufficient strength in order to the resist external force.
- The housing should adopt radiation structure to satisfy the temperature specification.
- Acetic acid type and chlorine type materials for the cover case are not desirable because the former generates corrosive gas of attacking the polarizer at high temperature and the latter causes circuit break by electro-chemical reaction.
- Do not touch, push or rub the exposed polarizers with glass, tweezers or anything harder than HB pencil lead. Never rub with dust clothes with chemical treatment. Do not touch the surface of polarizer for bare hand or greasy cloth.(Some cosmetics deteriorate the polarizer.)
- When the surface becomes dusty, please wipe gently with absorbent cotton or other soft materials like chamois soaks with petroleum benzine. Normal-hexane is recommended for cleaning the adhesives used to attach front / rear polarizers. Do not use acetone, toluene and alcohol because they cause chemical damage to the polarizer.
- Wipe off saliva or water drops as soon as possible. Their long time contact with polarizer

### Operating

- The spike noise causes the mis-operation of circuits. It should be within the  $\pm 200\text{mV}$  level (Over and under shoot voltage)
- Response time depends on the temperature.(In lower temperature, it becomes longer.)
- Brightness depends on the temperature. (In lower temperature, it becomes lower.) And in lower temperature, response time(required time that brightness is stable after turned on) becomes longer.
- Be careful for condensation at sudden temperature change. Condensation makes damage to polarizer or electrical contacted parts. And after fading condensation, smear or spot will occur.
- When fixed patterns are displayed for a long time, remnant image is likely to occur.
- Module has high frequency circuits. Sufficient suppression to the electromagnetic interference shall be done by system manufacturers. Grounding and shielding methods may be important to minimized the interference

### Electrostatic Discharge Control

Since a module is composed of electronic circuits, it is not strong to electrostatic discharge. Make certain that treatment persons are connected to ground through wrist band etc. And don't touch interface pin directly.

### Strong Light Exposure

Strong light exposure causes degradation of polarizer and color filter.

### Storage

When storing modules as spares for a long time, the following precautions are necessary.

- Store them in a dark place. Do not expose the module to sunlight or fluorescent light. Keep the temperature between  $5^{\circ}\text{C}$  and  $35^{\circ}\text{C}$  at normal humidity.
- The polarizer surface should not come in contact with any other object. It is recommended that they be stored in the container in which they were shipped.

### Protection Film

- When the protection film is peeled off, static electricity is generated between the film and polarizer. This should be peeled off slowly and carefully by people who are electrically grounded and with well ion-blown equipment or in such a condition, etc.
- The protection film is attached to the polarizer with a small amount of glue. If some stress is applied to rub the protection film against the polarizer during the time you peel off the film, the glue is apt to be main on the polarizer. Please carefully peel off the protection film without rubbing it against the polarizer.
- When the module with protection film attached is stored for a long time, sometimes there remains a very small amount of glue still on the polarizer after the protection film is peeled off.
- You can remove the glue easily. When the glue remains on the polarizer surface or its vestige is recognized, please wipe them off with absorbent cotton waste or other soft material like chamois soaked with normal-hexane.

### Transportation

The LCD modules should be no falling and violent shocking during transportation, and also should avoid excessive press, water, damp and sunshine.