



深圳市拓普微科技开发有限公司

SHENZHEN TOPWAY TECHNOLOGY CO.,LTD.

MODEL NO. : LMT035DNRFWD

ISSUED DATE: 2016-01-11

VERSION: Ver 0.1

- Preliminary Specification
 Final Product Specification

Customer :

Approved by	Notes

Confirmed :

Prepared by	Checked by	Approved by
Zou Guo Rui		

This technical specification is subjected to change without notice

Table of Contents

.....	1
Record of Revision.....	3
1. General Specifications	4
2. Input/Output Terminals	5
3 Absolute Maximum Ratings	6
4 Electrical Characteristics.....	7
4.1 Driving TFT LCD Panel	7
4.2 Driving Backlight	7
4.3 Block Diagram	8
5. Data input timing	9
5.1 SYNC mode.....	9
5.2 DE Mode.....	9
5.3 AC input characteristics.....	10
5.4 Timing Diagram.....	11
5.5 Power ON/OFF Sequence	12
6. Optical Characteristics	13
7. Environmental / Reliability Test	16
8. Mechanical Drawing	17
9. Packing Drawing	18
10. Precaution for Use of LCD Modules	22

Record of Revision

Rev	Issued Date	Description	Editor
0.1	2016-01-11	Preliminary release.	Zou Guo Rui

1. General Specifications

Feature		Spec
Display Spec.	Size	3.5 inch
	Resolution	240(RGB) x 320
	Interface	RGB 6 bit+SPI
	Color Depth	262K
	Technology Type	a-Si
	Pixel Pitch (mm)	0.2235x0.2235
	Pixel Configuration	R.G.B. Vertical Stripe
	Display Mode	Transflective
	Surface Treatment(Up Polarizer)	HC
	Viewing Direction	6 o'clock
	Gray Scale Inversion Direction	12 o'clock
	LCM (W x H x D) (mm)	64.0x85.0x2.93
Mechanical Characteristics	Active Area(mm)	53.64x71.52
	With /Without TSP	Without TSP
	Weight (g)	33.2
	LED Numbers	6 LEDs

Note 1: Viewing direction for best image quality is different from TFT definition, there is a 180 degree shift.

Note 2: Requirements on Environmental Protection: Q/S0002

Note 3: LCM weight tolerance: $\pm 5\%$

2. Input/Output Terminals

2.1 J1 Pin Assignment

Connector type: FH12A-50S-0.5SH

No	Symbol	I/O	Description	Comment
1	VL1	P	Power supply for LED(High voltage)	
2	GND	P	Ground	
3	VL2	P	Power supply for LED(Low voltage)	
4	GND	P	Ground	
5	VSHD	P	Power supply for digital	
6	GND	P	Ground	
7	GND	P	Ground	
8	GND	P	Ground	
9	VSYNC	I	Vertical sync. in RGB mode	
10	GND	P	Ground	
11	RESET	I	Reset(Low active)	
12	GND	P	Ground	
13	GND	P	Ground	
14	GND	P	Ground	
15	CS	I	Chip select input(Low enable)	
16	GND	P	Ground	
17	SDO	O	Serial data output	
18	SDI	I	Serial data input	
19	GND	P	Ground	
20	SCL	I	Serial interface clock	
21	GND	P	Ground	
22	B5	I	Blue data input(MSB)	
23	B4	I	Blue data input	
24	B3	I	Blue data input	
25	B2	I	Blue data input	
26	B1	I	Blue data input	
27	B0	I	Blue data input(LSB)	
28	ENAB	I	Data enable in RGB mode	
29	GND	P	Ground	
30	HSYNC	I	Horizontal sync. in RGB mode	
31	GND	P	Ground	
32	DCLK	I	Pixel clock signal in RGB mode	
33	GND	P	Ground	
34	G5	I	Green data input(MSB)	
35	G4	I	Green data input	
36	G3	I	Green data input	
37	G2	I	Green data input	
38	G1	I	Green data input	
39	G0	I	Green data input(LSB)	
40	GND	P	Ground	
41	R5	I	Red data input(MSB)	
42	R4	I	Red data input	
43	R3	I	Red data input	
44	R2	I	Red data input	

The information contained herein is the exclusive property of SHENZHEN TOPWAY TECHNOLOGY CO.,LTD. and shall not be distributed, reproduced, or disclosed in whole or in part without prior written permission of SHENZHEN TOPWAY TECHNOLOGY CO.,LTD..

LMT035DNRFWD

45	R1	I	Red data input	
46	R0	I	Red data input(LSB)	
47	GND	P	Ground	
48	GND	P	Ground	
49	GND	P	Ground	
50	GND	P	Ground	

Note1: I/O definition:

I----Input O----Output P----Power/Ground

3 Absolute Maximum Ratings

3.1 Driving TFT LCD Panel

GND=0V, Ta=25°C

Item	Symbol	Min	Max	Unit	Remark
Supply Voltage	VSHD	-0.3	4.6	V	
Driver supply voltage	VGH-VGL	-0.3	+32.0	V	
Logic input voltage range	VIN	-0.3	VSHD + 0.3	V	
Logic output voltage range	VO	-0.3	VSHD + 0.3	V	
Operating temperature	Top	-20.0	60.0	°C	Note1
Storage temperature	Tst	-30.0	70.0	°C	Note1

Note1: The parameter is for driver IC (gate driver, source driver) only.

Note2: Signals include R0~R5, G0~G5, B0~B5, DCLK, Hsync, Vsync, Reset, CS, SDI, SCL, ..ENABLE

Table 3.1 absolute maximum rating

4 Electrical Characteristics

GND=0V, Ta=25°C

4.1 Driving TFT LCD Panel

Item	Symbol	Min	Typ	Max	Unit	Remark	
Supply Voltage	VCC	2.5	2.8	3.2	V		
Gate on voltage	VGH	13.5	15.0	16.5	V		
Gate off voltage	VGL	-11.0	-10.0	-9.0	V		
Input Signal Voltage	Low Level	V _{IL}	0	-	0.3xVCC	V	R0~R5;G0~G5;B0~B5 DOTCLK; Hsync; Vsync ENABLE;R/L;U/D
	High Level	V _{IH}	0.7xVCC	-	VCC	V	
Current of VSHD Power supply	I _{CC}	-	15	-	mA	Note 1	

Note1: For different LCM, the value may have a bit of difference.

Note2: To test the current dissipation, use "all Black Pattern".

Table 4.1 LCD module electrical characteristics

4.2 Driving Backlight

Item	Symbol	Min	Typ	Max	Unit	Remark
Forward Current	I _F	-	20	-	mA	
Forward Voltage	V _{BL}	-	19.2	-	V	
Backlight Power Consumption	W _{BL}	-	384	-	mW	
Life Time	-	10,000	-	-	Hrs	Note 3

Note 1: I_F is defined for one channel LED. There are total three LED channels in back light unit

Note 2: Optical performance should be evaluated at Ta=25°C only.

Note 3: If LED is driven by high current, high ambient temperature & humidity condition. The life time of LED will be reduced. Operating life means brightness goes down to 50% initial brightness. Typical operating life time is estimated data.

Table 4.2 LED backlight characteristics

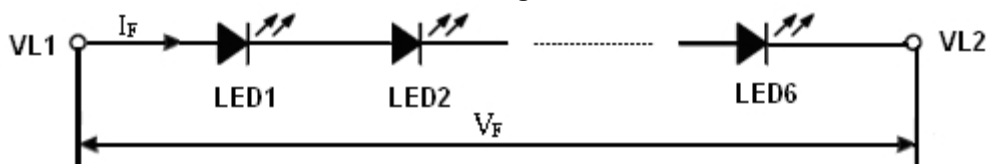
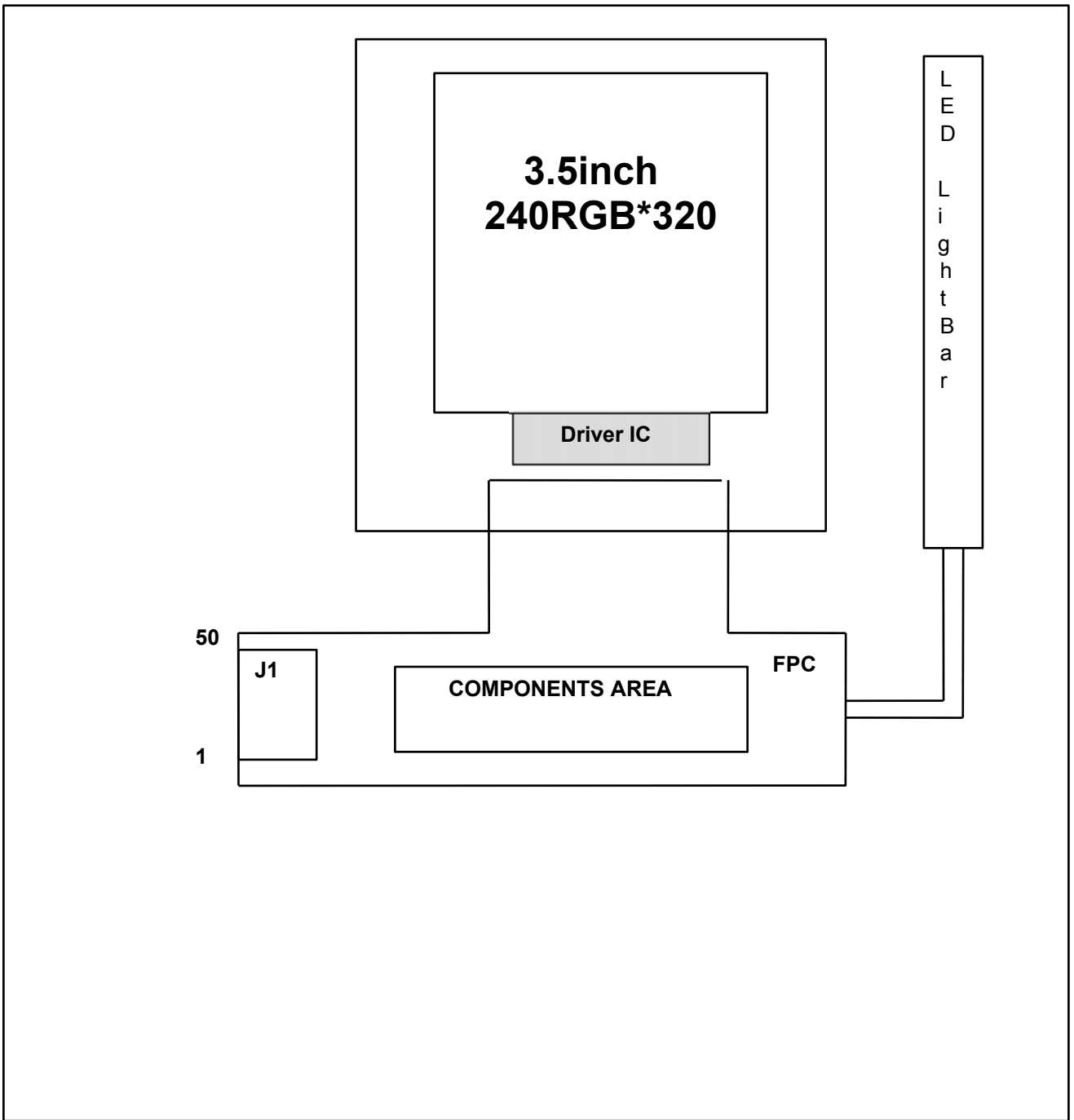

Figure 4.2 LED connection of backlight

4.3 Block Diagram



5. Data input timing

5.1 Signal AC Timing

(VSHD=2.5~3.2V, Ta=25°C)

Parameter	Description	Min	Max	Unit	Remark
tSYNCS	VSYNC/HSYNC setup time	15		ns	
tSYNCH	VSYNC/HSYNC hold time	15		ns	
tENS	ENAB setup time	15		ns	
tENH	ENAB hold time	15		ns	
tPOS	Data setup time	15		ns	
tPDH	Data hold time	15		ns	
PWDH	DCLK high-level period	15		ns	
PWDL	DCLK low-level period	15		ns	
tCYCD	DCLK cycle time	100		ns	
trgbr , trgbf	DCLK,HSYNC,VSYNC rise/fall		15	ns	

Table 5.1 RGB Interface Characteristics

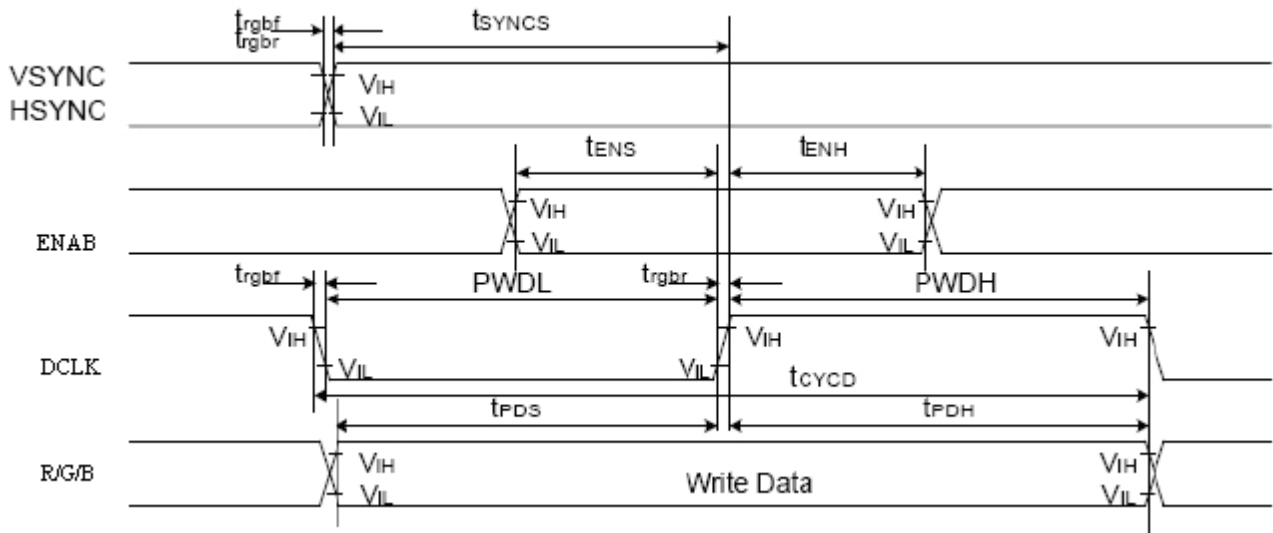

Fig.5-1 RGB Interface Timing

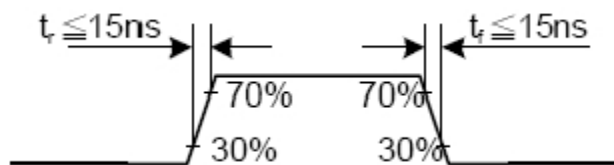

Fig.5-2 Input signal's rise and fall times

5.2 Recommend RGB Interface Timing

(VSHD=2.5~3.2V, Ta=25°C)

Parameter	Symbol	Symbol	Min	Typ	Max	Unit	Remark
DCLK	DCLK frequency	fDCYC	-	5.64	10	MHz	
	DCLK period	tDCYC	100	177.15	-	ns	
HSYNC	Horizontal	Thd	240			DCLK	
	1horizontalline	Th	-	310	-		
	Horizontal blank	Thb	56	60	-		
	Horizontal front porch	Thfp	2	10	16		
VSYNC	Vertical display area	Tvd	320			Line	
	Vsync period time	Tv	-	328	-		
	Vsync blank	Tvb	2	4	-		
	Vsync Front porch	Tvfp	2	4	-		

Tab.5-2 Recommend Input Timing (DCLK, HSYNC, VSYNC, ENAB)

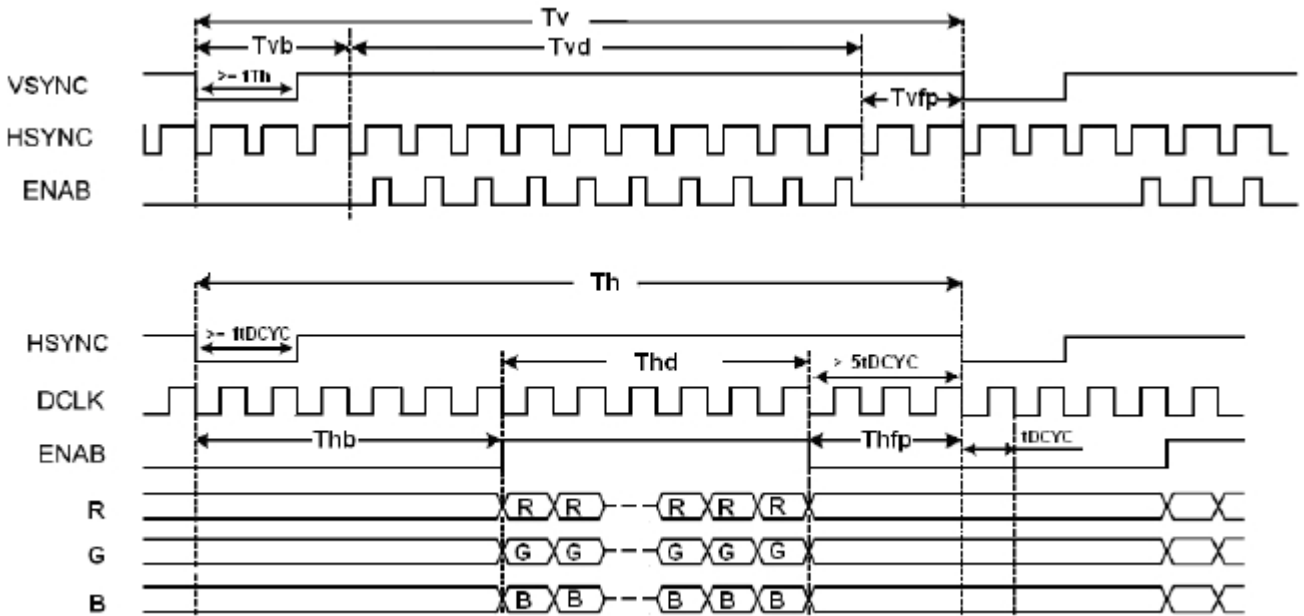

Fig.5-3 Recommend RGB Interface Timing

5.2 3-Wire 9-BIT Serial Interface

5.2.1 3-Wire 9-Bit data serial interface write mode

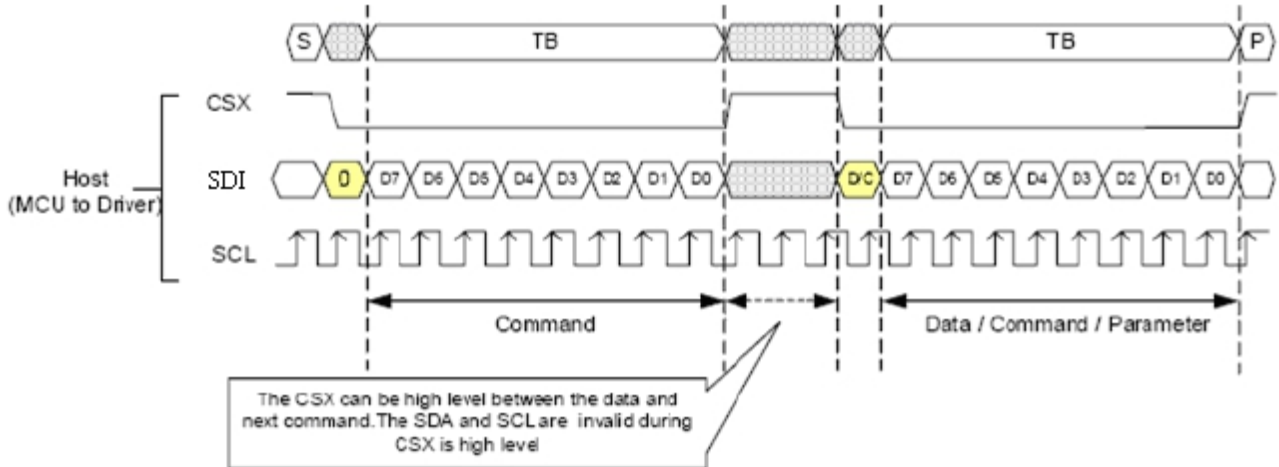

Figure. 5-4 3-Wire 9-Bit Serial Interface I Bus Protocol, Write to Register or Display RAM

Note: D/C =0, Transfer Command; D/C =1, Transfer Data.

5.2.2 3-Wire 9-Bit data serial interface read 1-byte mode

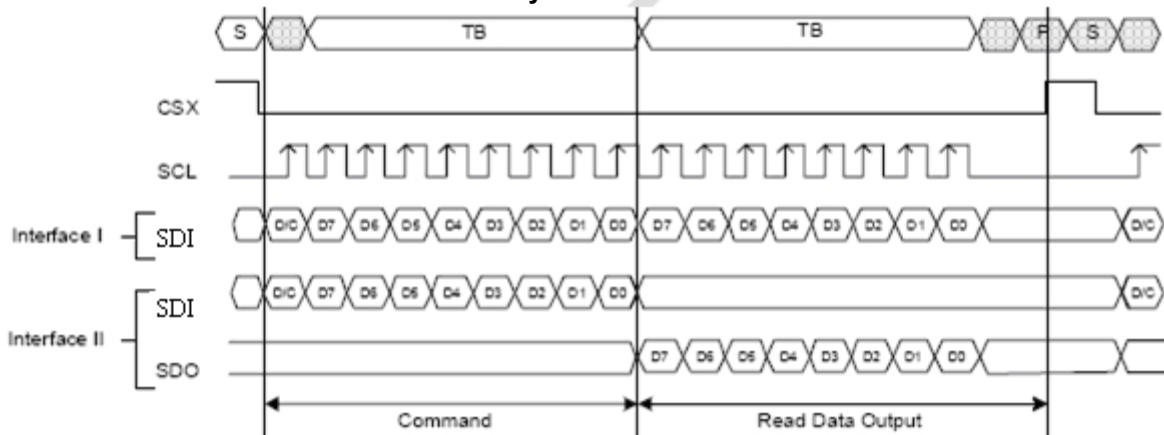

Figure. 5-5 3-Wire 9-Bit Serial Interface I/II Bus Protocol, Read 1-Byte From Register

Note: D/C=0, Transfer Command; D/C=1, Transfer Data.

5.2.3 3-Wire 9-Bit data serial interface read 3-byte mode

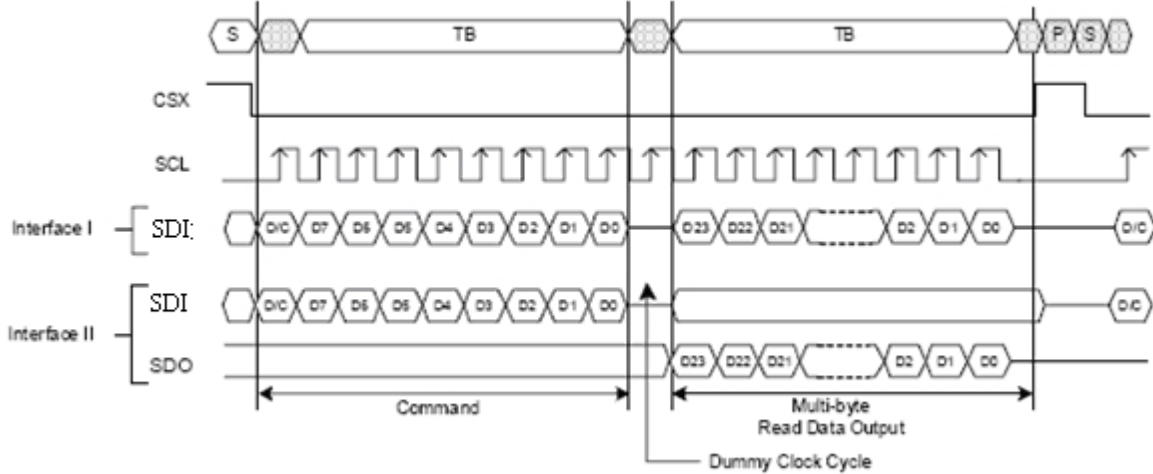

Figure. 5-6 3-Wire 9-Bit Serial Interface I/II Bus Protocol, Read 3-Byte From Register

Note: D/C=0, Transfer Command; D/C=1, Transfer Data.

5.2.4 3-Wire 9-Bit serial interface Timing

(VSHD=2.5~3.2V, Ta=25°C)

Parameter	Symbol	Conditions	Min	Max	Unit	Remark
Serial Clock Cycle(Write)	tscycw	SCL	100	-	ns	
SCL "H" pluse width(Write)	tshw	SCL	40	-	ns	
SCL "L" pluse width(Write)	tslw	SCL	40	-	ns	
Data setup time(Write)	tsds	SDI	30	-	ns	
Data hold time(Write)	tsdh	SDI	30	-	ns	
Serial Clock Cycle(Read)	tscycr	SCL	150	-	ns	
SCL "H" pluse width(Read)	tshr	SCL	60	-	ns	
SCL "L" pluse width(Read)	tslr	SCL	60	-	ns	
Access time	tacc	SDO(Read)	10		ns	
Output disable time	toh	SDO(Read)	10	50	ns	
CS "H" pluse width	tchw	CS	40	-	ns	
CS-SCL time	tcss	CS (Write)	60	-	ns	
	tcssh	CS (Write)	65	-	ns	

Tab.5-3 AC Characteristics of 3-Wire 9-Bit Serial Interface

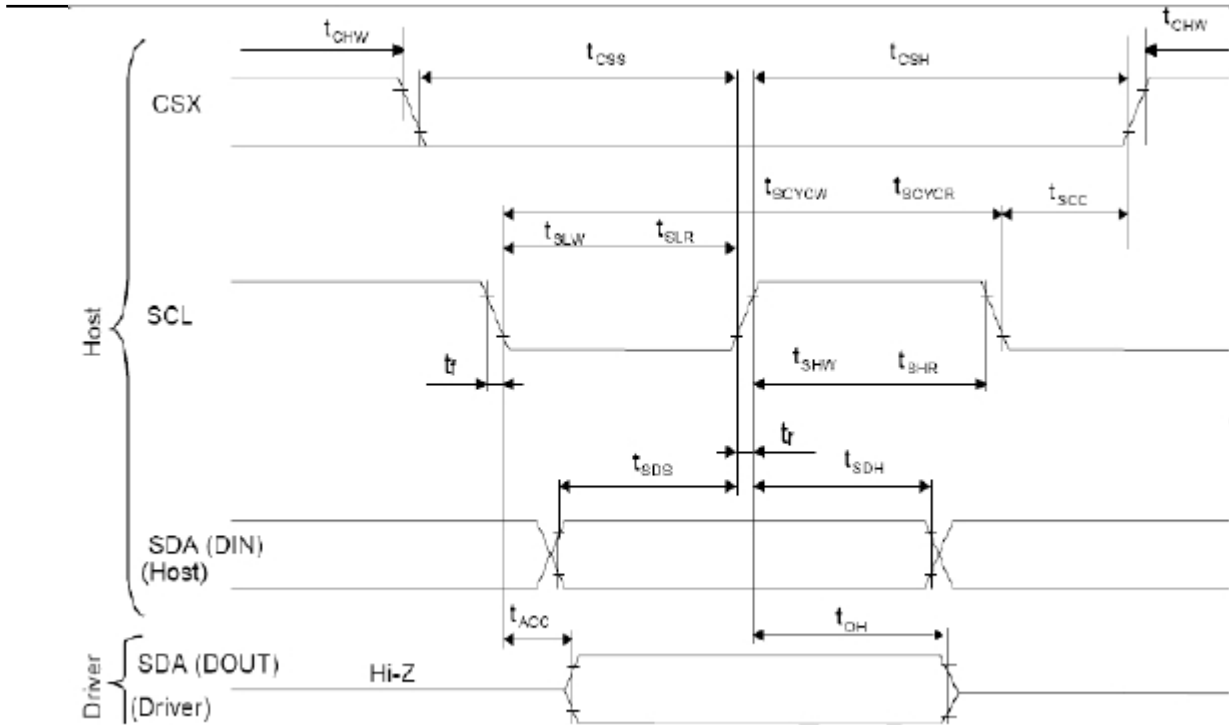

Fig.5-7 AC Characteristics of 3-Wire 9-Bit Serial Interface timing

5.3 Reset Timing

Parameter	Symbol	MIN	TYP	MAX	Unit	Remark
RESET	t_{RW}	10	-	-	us	-
	t_{RT}	-	-	5	ms	note 1
		-	-	120	ms	note 2

Tab.5-4 Reset input timing

Note1: When Reset applied during Sleep In Mode.
 Note2: When Reset applied during Sleep Out Mode.

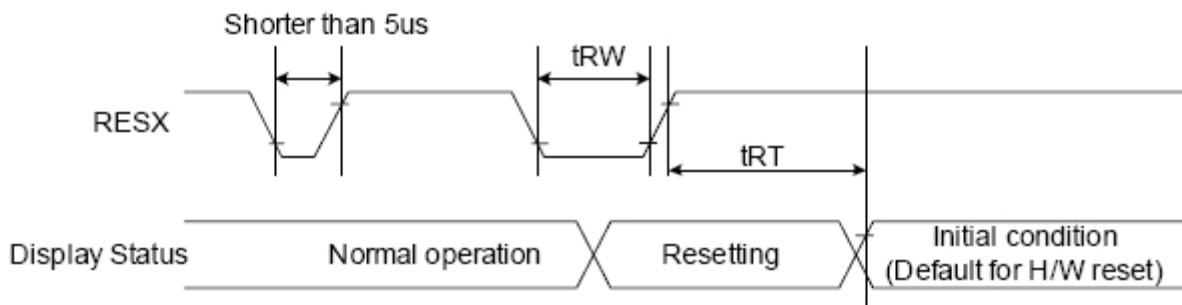

Fig.5-8 Reset timing

The information contained herein is the exclusive property of SHENZHEN TOPWAY TECHNOLOGY CO.,LTD. and shall not be distributed, reproduced, or disclosed in whole or in part without prior written permission of SHENZHEN TOPWAY TECHNOLOGY CO.,LTD..

5.5 Power ON/OFF Sequence

Item	Symbol	Min	Typ	Max	Unit	Remark
VSHD to RESET2 ending/ RESET2 starting to VSHD	t1	10			ms	
RESET2 ending to SPI starting/ SPI ending to RESET2 starting	t2	10	-	50	ms	
SPI starting to RGB starting/ RGB ending to SPI ending	t3	20	-	50	ms	
RGB starting to BLU starting/ BLU ending to RGB ending	t4	50	-	-	ms	
RGB ending to RESET1 starting	t5	20	-	-	ms	

Table 5.5 Power on/off sequence

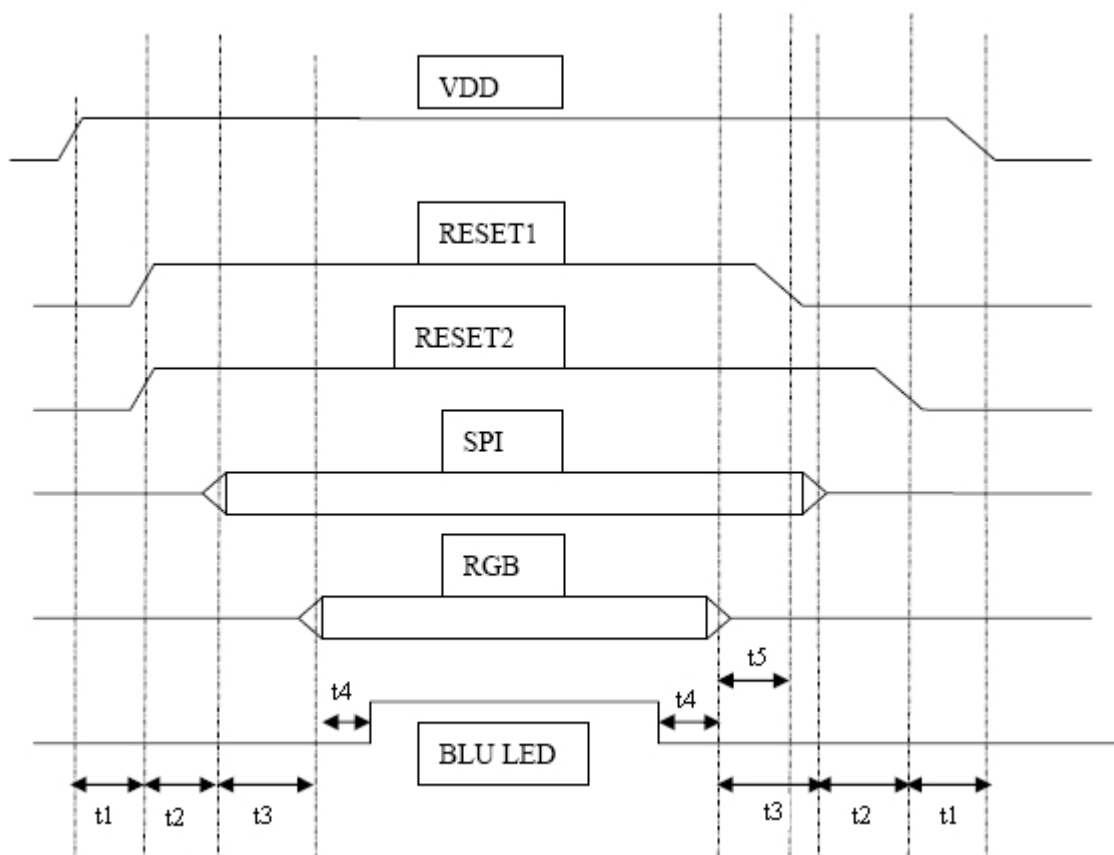

Figure 5.5 Power on/off sequence

Note1:RESET1Power down in sleep out mode.

Note2:RESET2 Power down in sleep in mode.

6. Optical Characteristics

6.1 Driving the backlight condition

Ta=25°C

Item	Symbol	Condition	Min	Typ	Max	Unit	Remark	
View Angles	θT	CR ≥ 10	50	55	--	Degree	Note 2	
	θB		35	40	--			
	θL		35	40	--			
	θR		40	45	--			
Contrast Ratio	CR	θ=0°	100	150	--		Note1、 Note3	
Response Time	T _{ON}	25°C	--	35	--	ms	Note1	
	T _{OFF}						Note4	
Chromaticity	White	Backlight is on	W _x	0.240	0.290	0.340	Note5	
			W _y	0.250	0.300	0.350		
	Red		R _x	0.530	0.580	0.630		
			R _y	0.270	0.320	0.370		
	Green		G _x	0.270	0.320	0.370		Note1
			G _y	0.410	0.460	0.510		
	Blue		B _x	0.100	0.150	0.200		
			B _y	0.080	0.130	0.180		
Luminance	L		80	100	--	cd/m ²	Note1、 Note7	

6.1 Not driving the backlight condition

Ta=25°C

Item	Symbol	Condition	Min	Typ	Max	Unit	Remark
View Angles	θT	CR ≥ 2	30	35	--	Degree	Note 2
	θB		35	40	--		
	θL		30	35	--		
	θR		30	35	--		
Contrast Ratio	CR	θ=0°	2.0	2.5	--		Note1、 Note3
Chromaticity	White	Backlight is off	x	0.260	0.310	0.360	Note5
			y	0.270	0.320	0.370	
Reflectance			--	5.5	--	%	Note1、 Note6

Test Conditions:

1. I_F= 20mA, V_F=19.2V, the ambient temperature is 25°C.
2. The test systems refer to Note 1 and Note 2.

Note 1: Definition of optical measurement system.

The optical characteristics should be measured in dark room. After 5 Minutes operation, the optical properties are measured at the center point of the LCD screen. All input terminals LCD panel must be ground when measuring the center area of the panel.

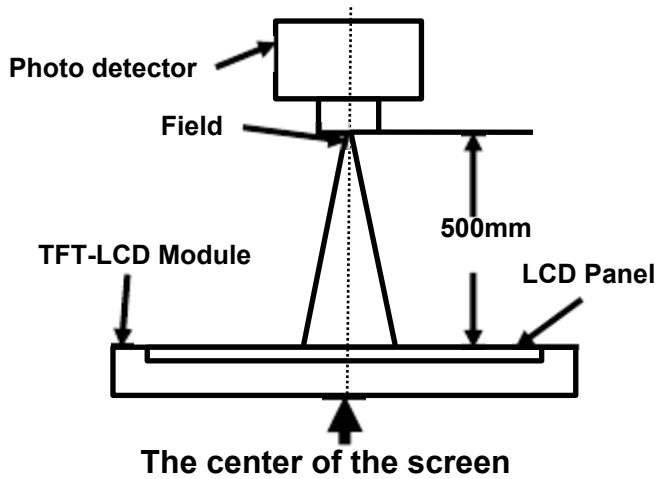

Item	Photo detector	Field
Contrast Ratio	SR-3A	1°
Luminance		
Chromaticity		
Lum Uniformity		
Response Time	BM-7A	2°

Note 2: Definition of viewing angle range and measurement system.

viewing angle is measured at the center point of the LCD by CONOSCOPE(ergo-80).

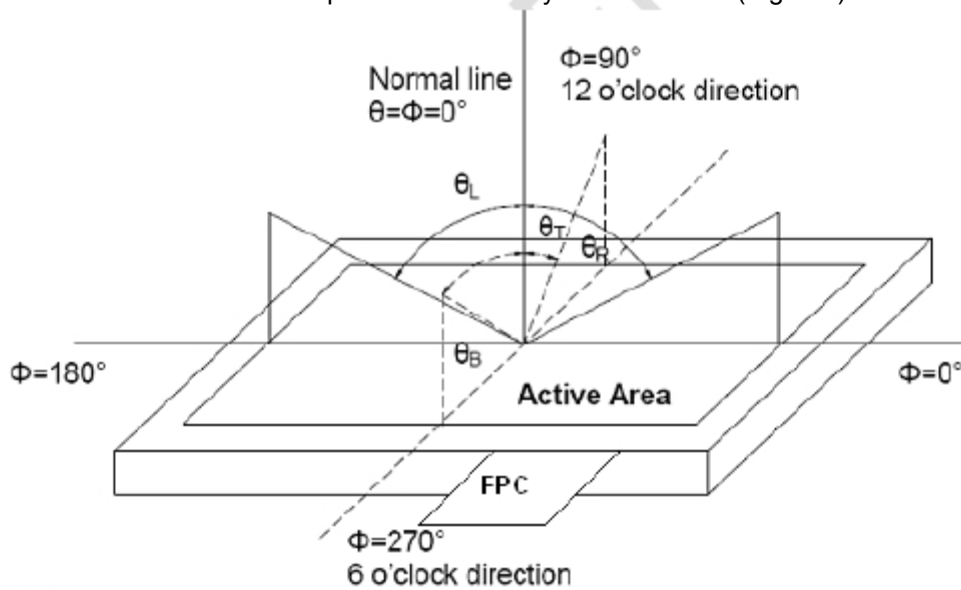

Note 3: Definition of contrast ratio

$$\text{Contrast ratio (CR)} = \frac{\text{Luminance measured when LCD is on the "White" state}}{\text{Luminance measured when LCD is on the "Black" state}}$$

“White state “: The state is that the LCD should drive by V_{white}.

“Black state”: The state is that the LCD should drive by V_{black}.

V_{white}: To be determined V_{black}: To be determined.

Note 4: Definition of Response time

The response time is defined as the LCD optical switching time interval between “White” state and “Black” state. Rise time (T_{ON}) is the time between photo detector output intensity changed from 90% to 10%. And fall time (T_{OFF}) is the time between photo detector output intensity changed from 10% to 90%.

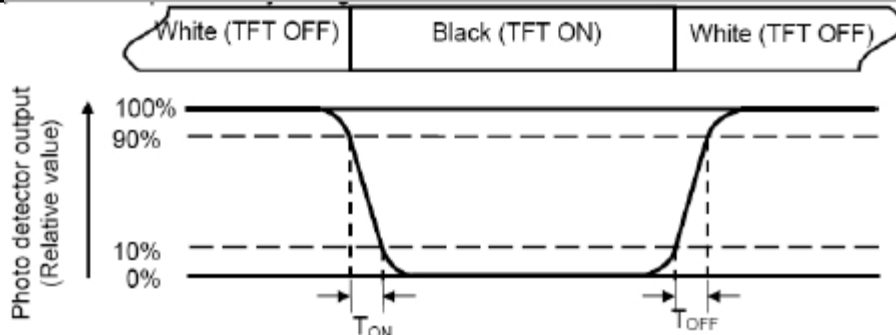

Note 5: Definition of color chromaticity (CIE1931)
 Color coordinates measured at center point of LCD.

Note 6: Definition of Luminance Uniformity
 Active area is divided into 9 measuring areas (Refer Fig. 2). Every measuring point is placed at the center of each measuring area.

$$\text{Luminance Uniformity (U)} = L_{\min} / L_{\max}$$

L-----Active area length W----- Active area width

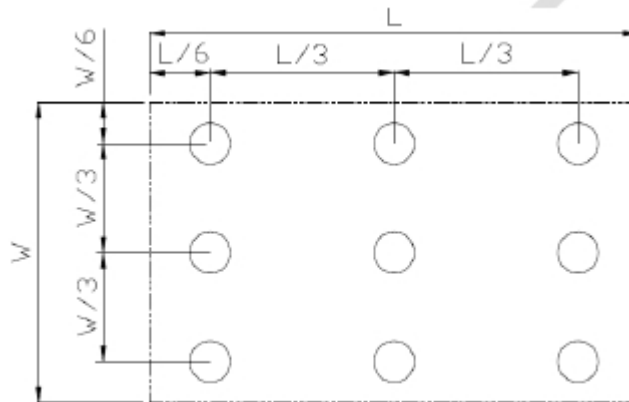

L_{\max} : The measured Maximum luminance of all measurement position.

L_{\min} : The measured Minimum luminance of all measurement position.

Note 7: Definition of Luminance:

Measure the luminance of white state at center point.

7. Environmental / Reliability Test

No	Test Item	Condition	Remarks
1	High Temperature Operation	Ts = +60°C, 240 hours	Note1 IEC60068-2-1,GB2423.2
2	Low Temperature Operation	Ta = -20°C, 240 hours	IEC60068-2-1 GB2423.1
3	High Temperature Storage	Ta = +70°C, 240 hours	IEC60068-2-1 GB2423.2
4	Low Temperature Storage	Ta = -30°C, 240 hours	IEC60068-2-1 GB2423.1
5	Storage at High Temperature and Humidity	Ta = +40°C, 90% RH max,240hours	Note2 IEC60068-2-78 GB/T2423.3
6	Thermal Shock (non-operation)	-30°C 30 min~+70°C 30 min, Change time:5min, 20 Cycle	Start with cold temperature, End with high temperature, IEC60068-2-14,GB2423.22
7	ESD	C=150pF,R=330Ω,5point/panel Air:±8Kv,5times; Contact:±4Kv,5times (Environment:15°C~35°C, 30%~60%.86Kpa~106Kpa)	IEC61000-4-2 GB/T17626.2
8	Vibration Test	Frequency range:10~55Hz Stroke:1.5mm Sweep:10Hz~55Hz~10Hz 30 minutes for each direction of X.Y.Z. (1.5 hours for total)	IEC60068-2-6 GB/T2423.10
9	Mechanical Shock (Non Op)	Half Sine Wave 100G 6ms, ±X,±Y,±Z 3times for each direction	IEC60068-2-27 GB/T2423.5
10	Package Drop Test	Height:60cm, 1corner,3edges,6surfaces	IEC60068-2-32 GB/T2423.8

Note1: Ts is the temperature of panel's surface.

Note2: Ta is the ambient temperature of samples.

8. Mechanical Drawing

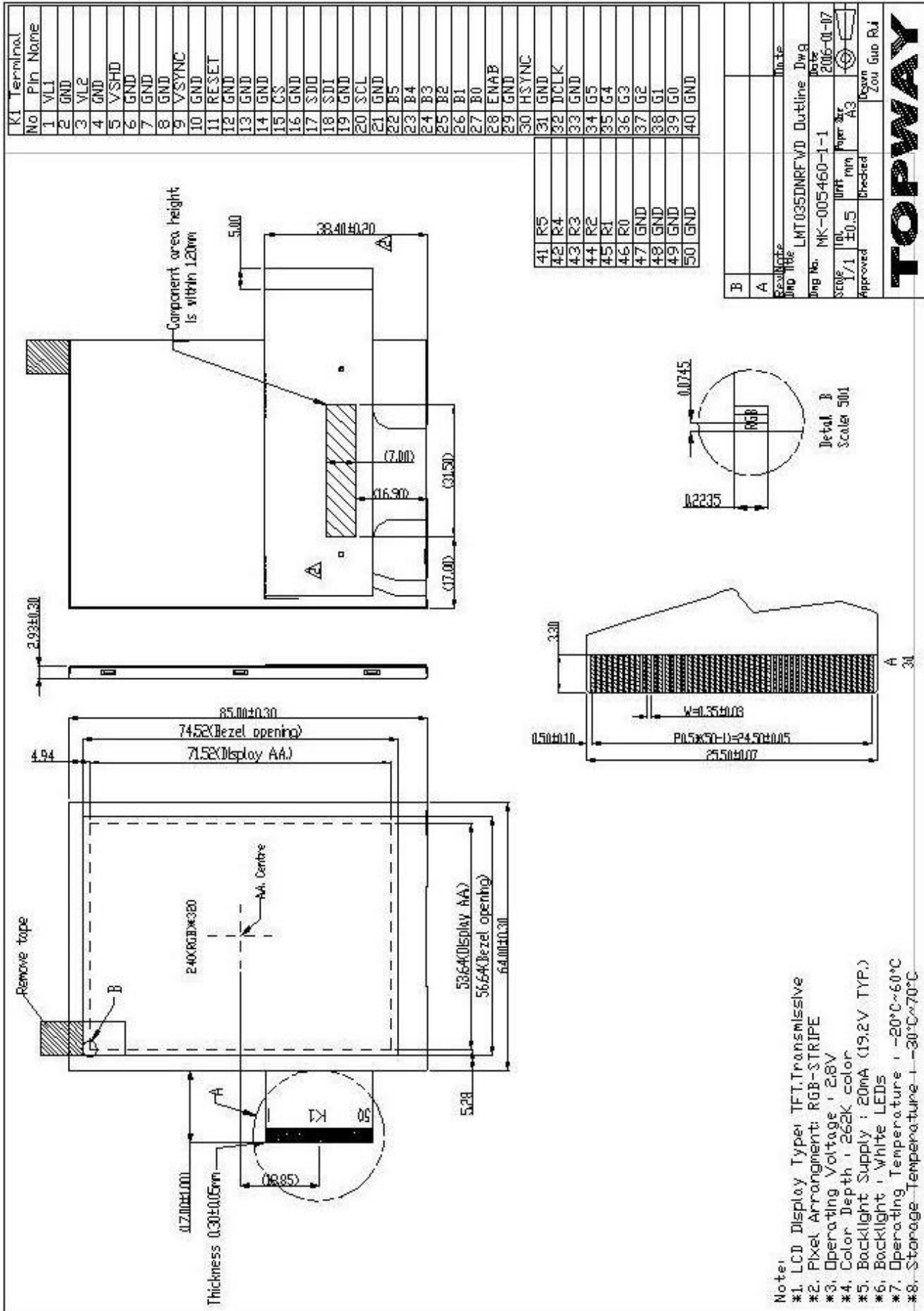

- Note:
- *1. LCD Display Type: TFT, Transmissive
 - *2. Pixel Arrangement: RGB-STRIPE
 - *3. Operating Voltage: 2.8V
 - *4. Color Depth: 262K color
 - *5. Backlight Supply: 20mA (19.2V TYP.)
 - *6. Backlight: White LEDs
 - *7. Operating Temperature: -20°C~60°C
 - *8. Storage Temperature: -30°C~70°C

The information contained herein is the exclusive property of SHENZHEN TOPWAY TECHNOLOGY CO.,LTD. and shall not be distributed, reproduced, or disclosed in whole or in part without prior written permission of SHENZHEN TOPWAY TECHNOLOGY CO.,LTD..

9. Packing Drawing

9.1 Packaging Material

No	Item	Model(Material)	Dimensions (mm)	Unit Weight (Kg)	Quantity	Remark
1	LCM module	TM035HDHT1-00	64.0x85.0x2.93	33.2	112	
2	Partition_1	Corrugated paper	513X333X106	TBD	2	
3	Anti-static Bag	PE	170X105X0.05	0.001	112	Anti-static
4	Dust-Proof Bag	PE	700X530	0.06	1	
5	Partition_2	Corrugated Paper	505X332X4.0	0.098	3	
6	Corrugated Bar	Corrugated paper	513X126	0.048	8	
7	Carton	Corrugated paper	516X336X226	1.12	1	
8	Total weight	TBD				

Note: Packaging Specification and Quantity

Module quantity in a carton: 28pcs(per row)x2(per column)x2= 112pcs

9.2 Packing Instruction

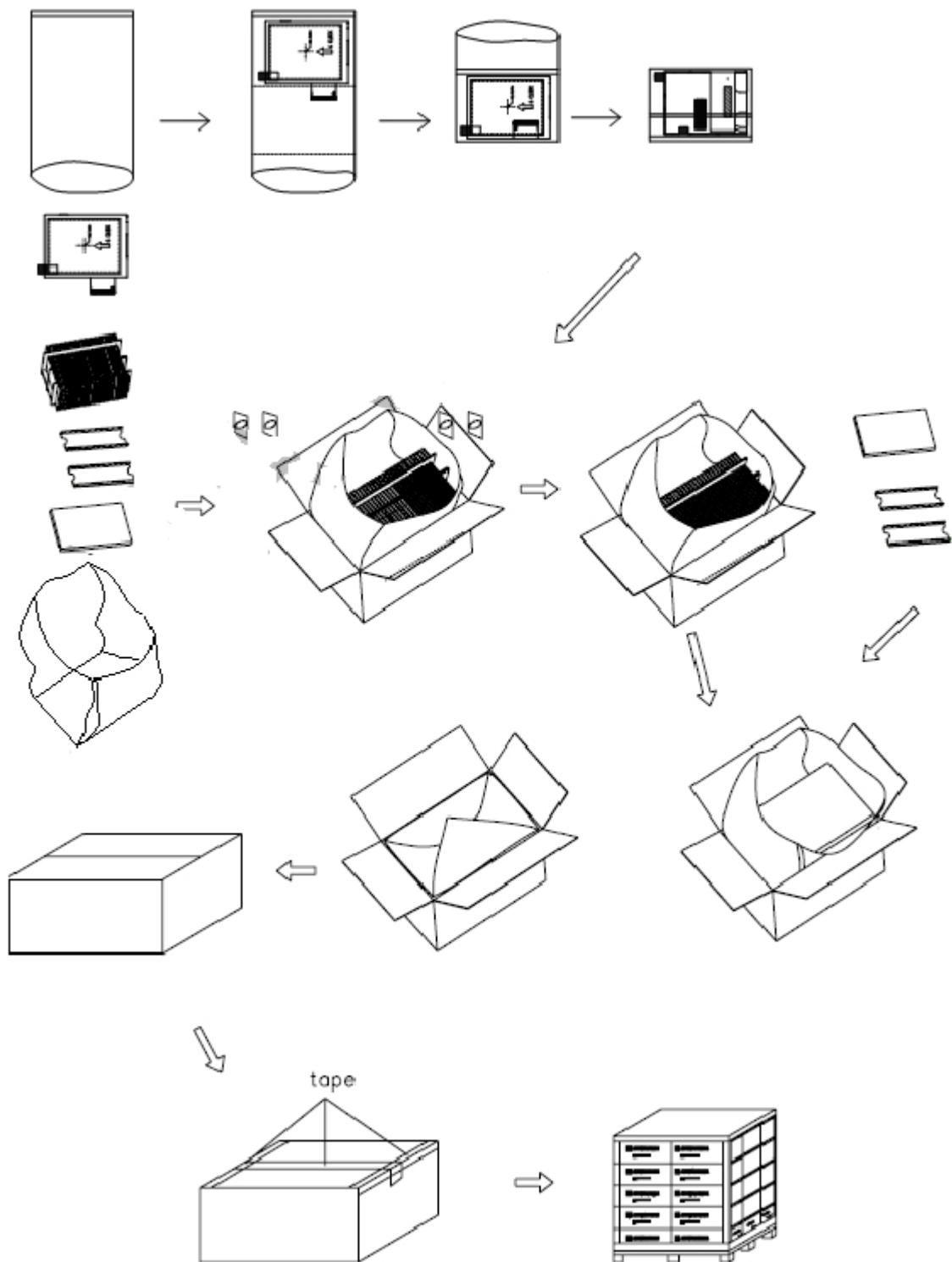

10. Precautions for Use of LCD Modules

10.1 Handling Precautions

10.1.1 The display panel is made of glass. Do not subject it to a mechanical shock by dropping it from a high place, etc.

10.1.2 If the display panel is damaged and the liquid crystal substance inside it leaks out, be sure not to get any in your mouth, if the substance comes into contact with your skin or clothes, promptly wash it off using soap and water.

10.1.3 Do not apply excessive force to the display surface or the adjoining areas since this may cause the color tone to vary.

10.1.4 The polarizer covering the display surface of the LCD module is soft and easily scratched. Handle this polarizer carefully.

10.1.5 If the display surface is contaminated, breathe on the surface and gently wipe it with a soft dry cloth. If still not completely clear, moisten cloth with one of the following solvents:

- Isopropyl alcohol
- Ethyl alcohol

Solvents other than those mentioned above may damage the polarizer. Especially, do not use the following:

- Water
- Ketone
- Aromatic solvents

10.1.6 Do not attempt to disassemble the LCD Module.

10.1.7 If the logic circuit power is off, do not apply the input signals.

10.1.8 To prevent destruction of the elements by static electricity, be careful to maintain an optimum work environment.

10.1.8.1 Be sure to ground the body when handling the LCD Modules.

10.1.8.2 Tools required for assembly, such as soldering irons, must be properly ground.

10.1.8.3 To reduce the amount of static electricity generated, do not conduct assembly and other work under dry conditions.

10.1.8.4 The LCD Module is coated with a film to protect the display surface. Be care when peeling off this protective film since static electricity may be generated.

10.2 Storage precautions

10.2.1 When storing the LCD modules, avoid exposure to direct sunlight or to the light of fluorescent lamps.

10.2.2 The LCD modules should be stored under the storage temperature range. If the LCD modules will be stored for a long time, the recommend condition is:

Temperature : 0°C ~ 40°C Relatively humidity: ≤80%

10.2.3 The LCD modules should be stored in the room without acid, alkali and harmful gas.

10.3 Transportation Precautions

10.3.1 The LCD modules should be no falling and violent shocking during transportation, and also should avoid excessive press, water, damp and sunshine.