



深圳市拓普微科技开发有限公司

SHENZHEN TOPWAY TECHNOLOGY CO., LTD.

LMT043DFFFWD

LCD Module User Manual

Prepared by: Li Yinyang Date: 2016-09-20	Checked by: Date:	Approved by: Date:
---	----------------------------------	-----------------------------------

Rev.	Descriptions	Release Date
0.1	Preliminary	2016-09-20

Table of Content

1. General Specification	3
2. Block Diagram	3
3. Terminal Functions	4
3.1 Interface	4
4. Absolute Maximum Ratings	5
5. Electrical Characteristics	5
5.1 DC Characteristics (MCU terminal).....	5
5.2 LED Backlight Circuit Characteristics.....	5
5.3 AC Characteristics	6
5.3.1 Clock and Date Input Timing Diagram	6
5.3.2 SYNC Mode Timing Diagram	7
5.3.3 DE Mode Timing Diagram	7
5.3.4 Power ON Sequence.....	8
5.3.5 Power Off Sequence	9
6. Optical Characteristics	9
7. Precautions of using LCD Modules	11
8. Appendix A <Inspection items and criteria for appearance defect>	12

1. General Specification

Screen Size(Diagonal) :	4.3 inch
Resolution :	480(RGB) x 272
Signal Interface :	24bit parallel interface
Color Depth :	16.7M color (24bit) *1
Dot Pitch :	0.198 x 0.198 (mm)
Pixel Configuration :	RGB Stripe
Display Mode :	Transmissive / Positive (normal white)
Surface Treatment :	Anti-Glare Treatment
Viewing Direction :	12 o'clock (Gray Scale Inversion Direction) (*2) 6 o'clock (*3)
Outline Dimension :	105.5 x 67.2 x 2.9 (mm) (exclude FPC, see attached drawing for details)
Active Area :	95.04 x 53.86 (mm)
Weight :	(44.4g)
Backlight :	2x5 LEDs
Driver IC	ST7282T
Operating Temperature :	-20 ~ +70°C
Storage Temperature :	-30 ~ +80°C

Note:

*1 Color tune may slightly changed by temperature and driving voltage.

*2 For saturated color display content (eg. pure-red, pure-green, pure-blue or pure-colors-combinations).

*3 For "color scales" display content.

2. Block Diagram

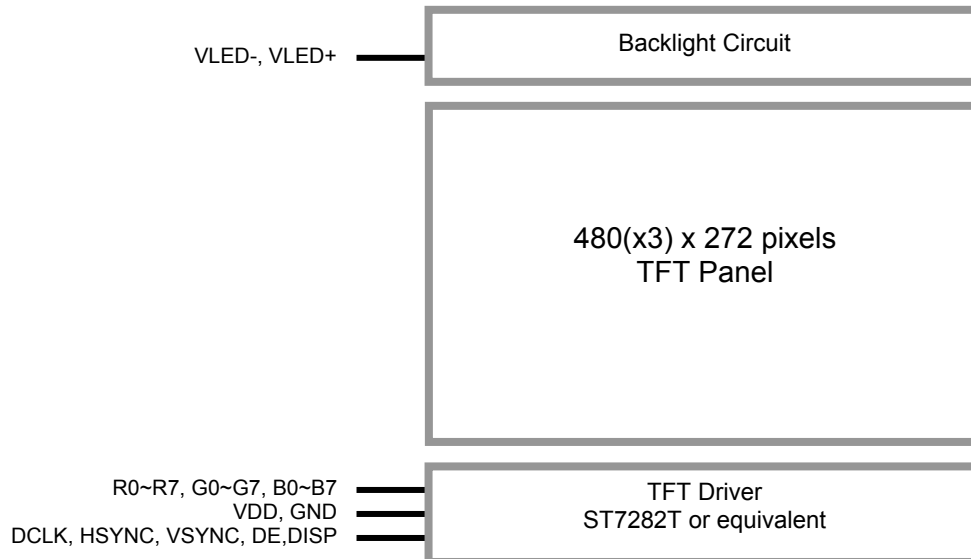

3. Terminal Functions

3.1 Interface

Pin No.	Pin Name	I/O	Descriptions
1	VLED-	P	Backlight LED Cathode supply
2	VLED+	P	Backlight LED Anode supply
3	GND	P	Power Ground (0V)
4	VDD	P	Positive Power Supply
5	R0	I	Red color data input
:	:		
12	R7		
13	G0	I	Green color data input
:	:		
20	G7		
21	B0	I	Blue color data input
:	:		
28	B7		
29	GND	P	Power Ground (0V)
30	DCLK	I	Data clock signal input, rising edge trigger
31	DISP	I	Display on/of control (internally pull low) DISP=0: standby mode DISP=1: normal operation
32	HSYNC	I	Horizontal Sync signal input, active low (If not using, pull high)
33	VSYNC	I	Vertical Sync Signal Input, active low (If not using, pull high)
34	DE	I	Data Enable Signal Input, active high (If not using, pull low)
35	NC	-	No connection, leave open
36	GND	P	Power Ground (0V)
37	NC	-	No connection, leave open
38	NC		
39	NC		
40	NC		

Note:

The LMT043DFFFWD both supports DE mode and Sync mode timing.
 SYNC mode, DE pull-lo, HSYNC and VSYNC for timing control
 DE mode, HSYNC and VSYNC pull-hi, DE for timing control

4. Absolute Maximum Ratings

Items	Symbol	Min.	Max.	Unit	Condition
Supply Voltage	V_{DD}	-0.3	+4.6	V	GND = 0V
Operating Temperature	T_{OP}	-20	+70	°C	No Condensation
Storage Temperature	T_{ST}	-30	+80	°C	No Condensation

Cautions:

Any Stresses exceeding the Absolute Maximum Ratings may cause substantial damage to the device. Functional operation of this device at other conditions beyond those listed in the specification is not implied and prolonged exposure to extreme conditions may affect device reliability.

5. Electrical Characteristics

5.1 DC Characteristics (MCU terminal)

GND=0V, V_{DD} =3.3V, T_{OP} =25°C

Items	Symbol	MIN.	TYP.	MAX.	Unit	Applicable Pin
Operating Voltage	V_{DD}	3.0	3.3	3.6	V	VDD
Input High Voltage	V_{IH}	0.7VDD	-	VDD	V	Input pins
Input Low Voltage	V_{IL}	GND	-	0.3VDD	V	Input pins
Frame Freq	F_{FRAME}	-	60	-	Hz	
Dot Data Clock	f_{DOTCLK}	-	9.0	15	MHz	
Operating Current (*1)	I_{DD}	-	18.4	-	mA	VDD
Standby Current (*2)	I_{DD}	-	15.2	-	uA	VDD

Note.

*1. test image is Black Mode, Frame Freq=60Hz

*2. DISP=0

5.2 LED Backlight Circuit Characteristics

$I_{f_{VLED+}}$ =40mA, T_{OP} =25°C

Items	Symbol	MIN.	TYP.	MAX.	Unit	Note
Forward Voltage	V_f	-	16.0	-	V	
Forward Current	$I_{f_{VLED+}}$	-	40	50	mA	
Life Time	-	10,000	(20,000)	-	hr	

Cautions:

Exceeding the recommended driving current could cause substantial damage to the backlight and shorten its lifetime.

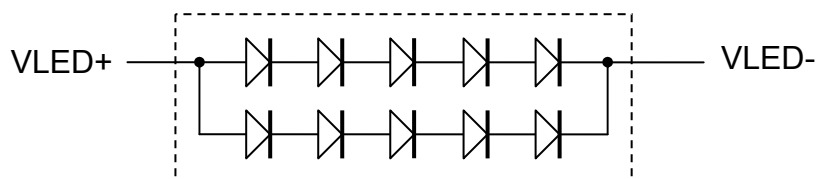

No. of LEDs = 2x5 pcs

5.3 AC Characteristics

5.3.1 Clock and Date Input Timing Diagram

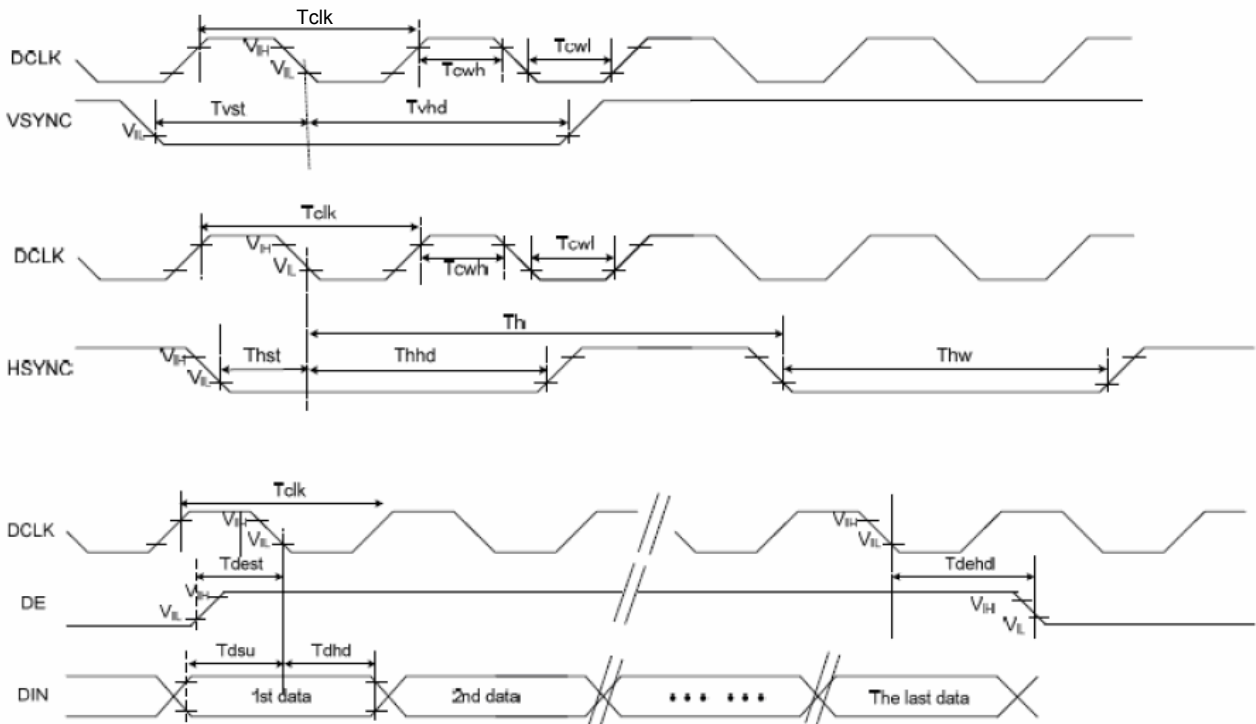

Timing Diagram

VDDI =3.3V, VDD=3.3V, AGND=0V, T_{OP} =25°C

Item	Symbol	Min.	Typ.	Max.	Unit	Conditions
System operation timing						
VDD power source slew time	TPOR	-	-	20	ms	From 0V to 99% VDD
GRB pulse width	trSTW	10	50	-	us	R=10Kohm, C=1uF
Input/ Output timing						
CLK pulse duty	Tcw	40	50	60	%	
Hsync width	Thw	1	-	-	DCLK	
Hsync period	Th	55	60	65	us	
Vsync setup time	Tvst	12	-	-	ns	
Vsync hold time	Tvhd	12	-	-	ns	
Hsync setup time	Thst	12	-	-	ns	
Hsync hold time	Thhd	12	-	-	ns	
Data setup time	Tdsu	12	-	-	ns	
Data hold time	Tdhhd	12	-	-	ns	
DE setup time	Tdest	10	-	-	ns	
DE hold time	Tdehd	10	-	-	ns	
SD output stable time	Tst	-	-	12	us	Output settled within +20mV Loading = 6.8k+28.2pF.
GD output rise and fall time	Tgst	-	-	6	us	Output settled (5%~95%), Loading = 4.7k+29.8pF
3-wire serial communication						
Delay between CSB and Vsync	Tcv	1			us	
CS input setup time	Ts0	50			ns	
Serial data input setup time	Ts1	50			ns	
CS input hold time	Th0	50			ns	
Serial data input hold time	Th1	50			ns	
SCL pulse high width	Twh1	50			ns	
SCL pulse low width	Twl1	50			ns	
CS pulse high width	Tw2	400			ns	

5.3.2 SYNC Mode Timing Diagram

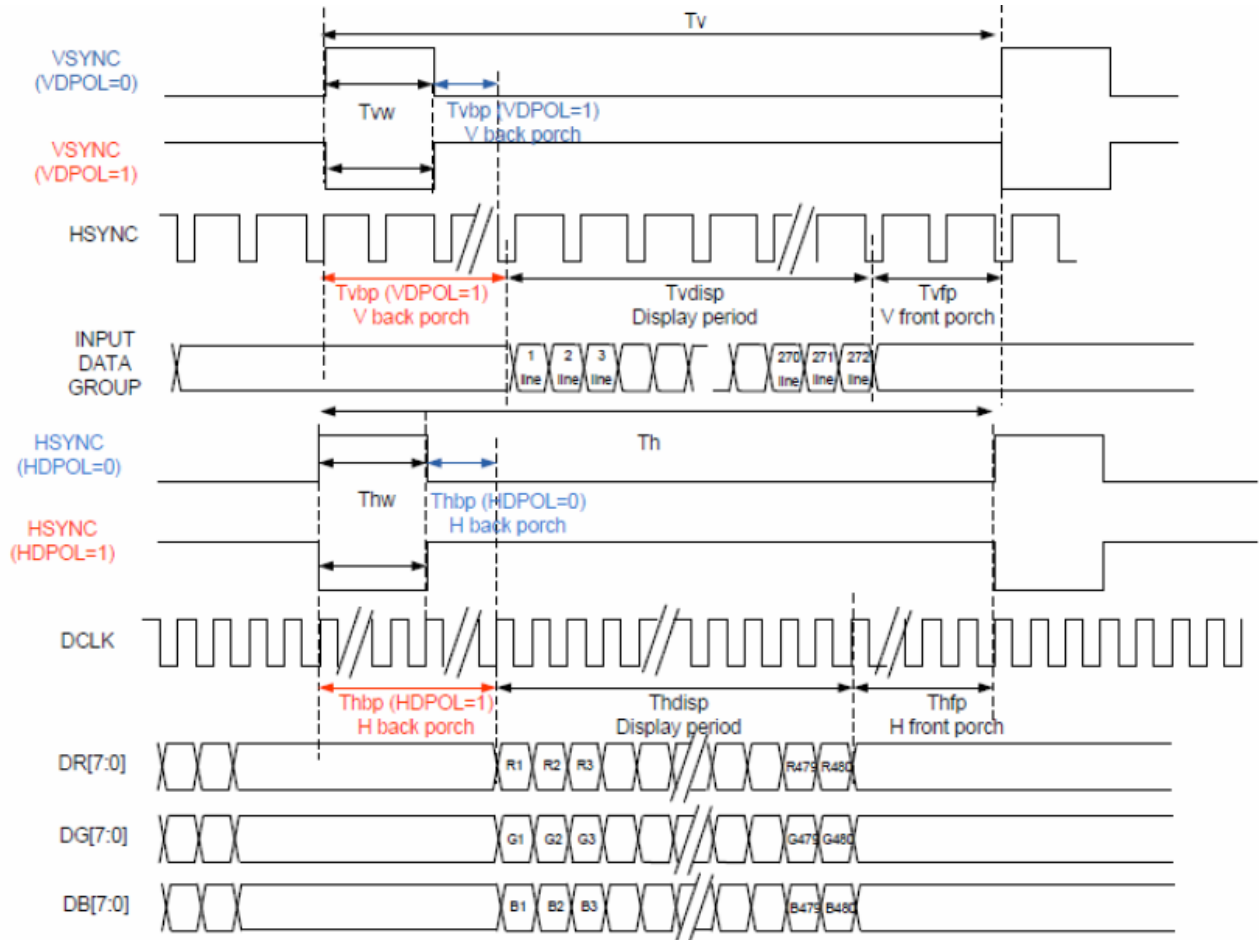

5.3.3 DE Mode Timing Diagram

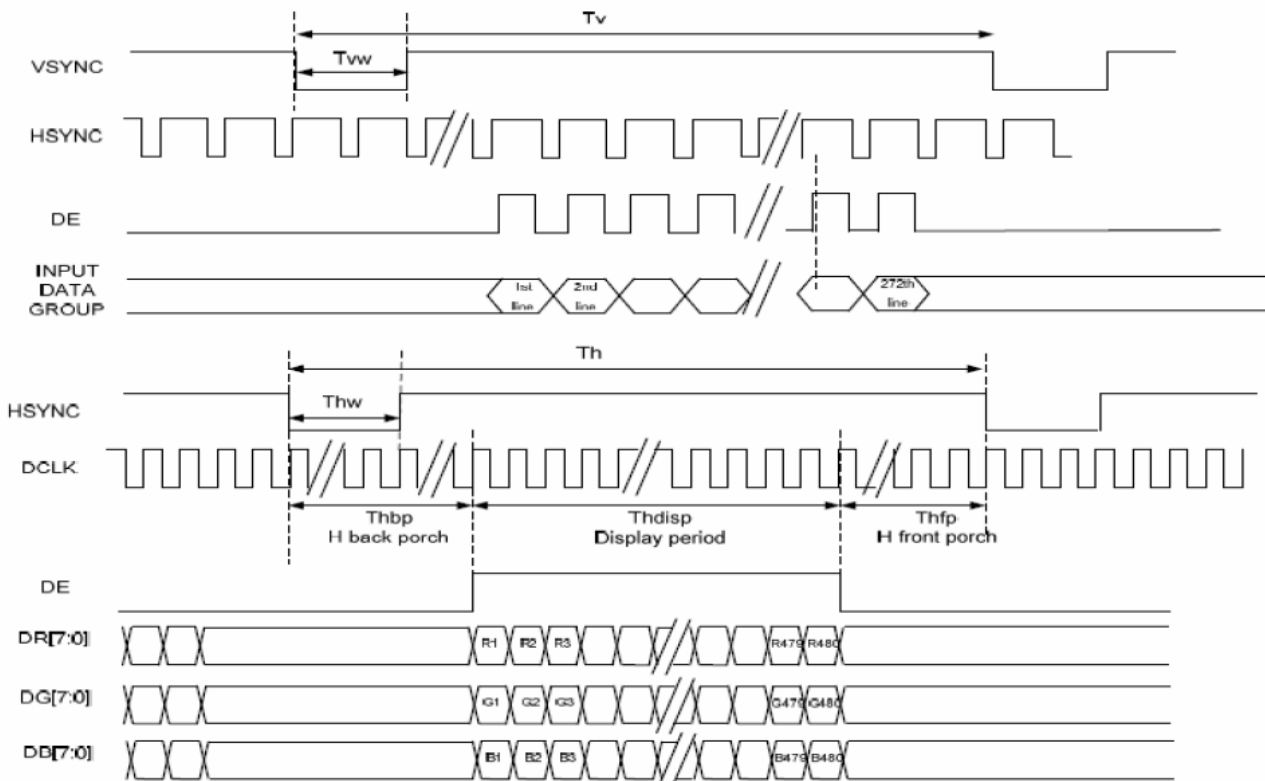

Item	Symbol	Min.	Typ.	Max.	Unit	Remark
DCLK Frequency	Fclk	8	9	12	MHz	
DCLK Period	Tclk	83	111	125	ns	
HSYNC	Period Time	Th	485	531	DCLK	
	Display Period	Thdisp		480	DCLK	
	Back Porch	Thbp	3	43	DCLK	By H_Blanking setting
	Front Porch	Thfp	2	8	DCLK	
	Pulse Width	Thw	2	4	DCLK	
VSYNC	Period Time	Tv	276	292	H	
	Display Period	Tvdisp		272	H	
	Back Porch	Tvbp	2	12	H	By V_Blanking setting
	Front Porch	Tvfp	2	8	H	
	Pulse Width	Tvw	2	4	H	

Note: It is necessary to keep Tvbp =12 and Thbp =43 in sync mode. DE mode is unnecessary to keep it.

5.3.4 Power ON Sequence

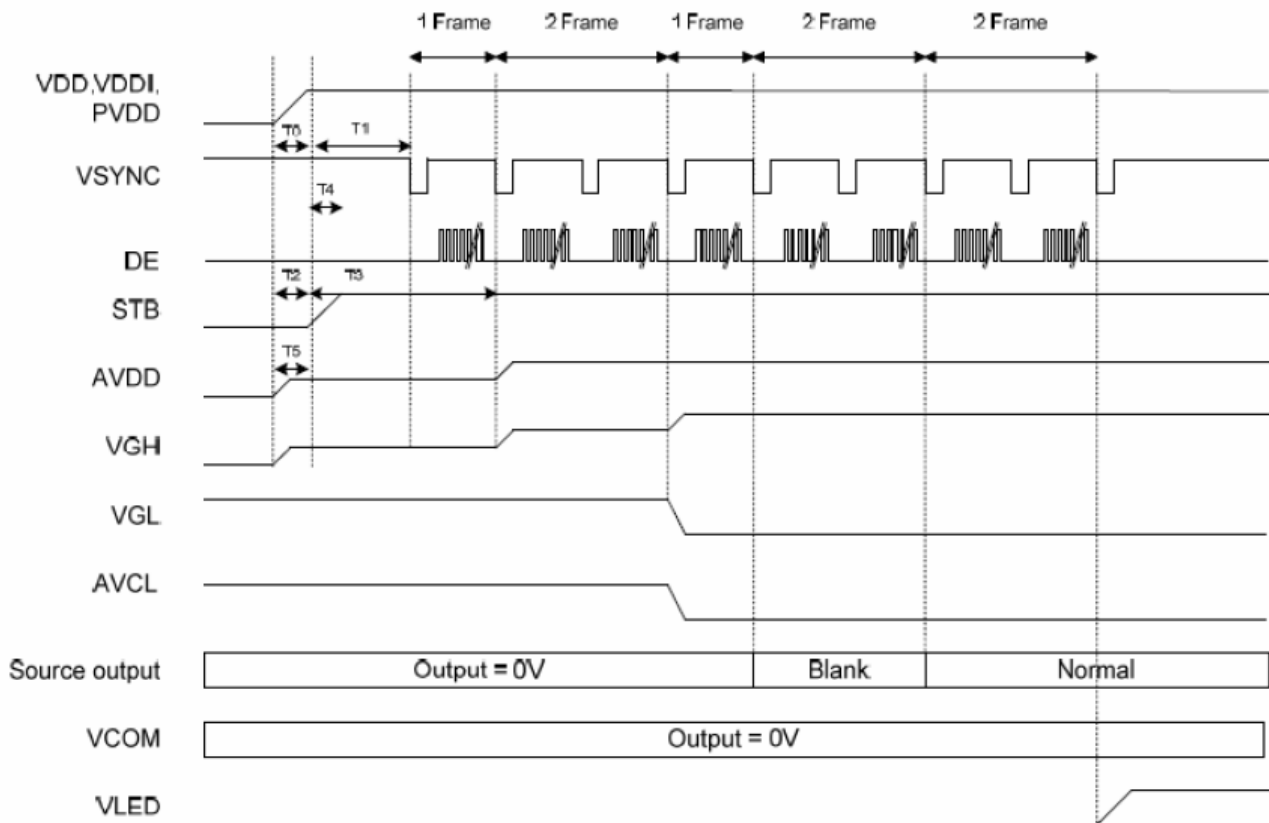

5.3.5 Power Off Sequence

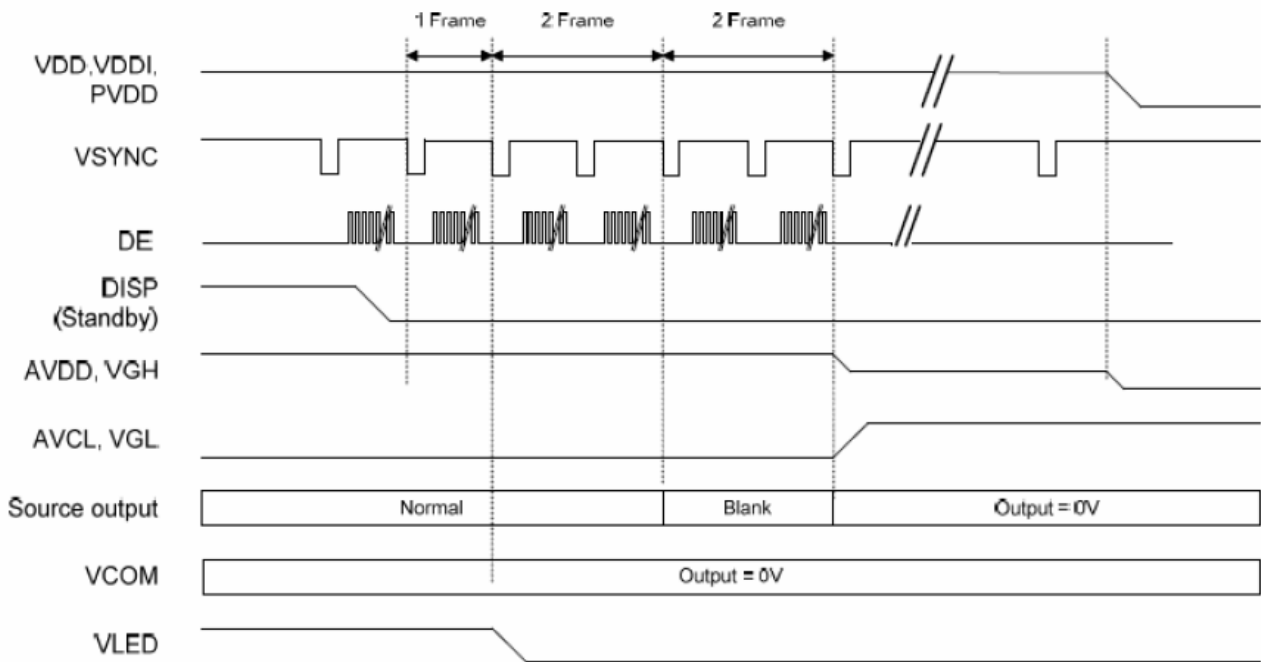

6. Optical Characteristics

Item	Symbol	Condition	Min	Typ	Max	Unit	Remark
View Angles	θT	$CR \geq 10$	70	80	-	Degree	Note 2,3
	θB		50	60	-		
	θL		70	80	-		
	θR		70	80	-		
Contrast Ratio	CR	$\theta = 0^\circ$	700	900	-		Note 3
Response Time	T_{ON}	25°C	-	20	30	ms	Note 4
	T_{OFF}						
Chromaticity	White	x	Backlight is on	0.255	0.305	0.355	Note 1,5
		y		0.277	0.327	0.377	
	Red	x		0.534	0.584	0.634	Note 1,5
		y		0.300	0.350	0.400	
	Green	x		0.290	0.340	0.390	Note 1,5
		y		0.543	0.593	0.643	
	Blue	x		0.102	0.152	0.202	Note 1,5
		y		0.040	0.090	0.140	
Uniformity	U		75	80	-	%	Note 6
NTSC			45	50	-	%	Note 5
Luminance	L		350	400	-	cd/m ²	Note 7

1. I_F = 40 mA, and the ambient temperature is 25°C.

2. The test systems refer to Note 1 and Note 2.

Note 1:
 The data are measured after LEDs are turned on for 5 minutes. LCM displays full white. The brightness is the average value of 9 measured spots. Measurement equipment SR-3A (1°)

- Measuring condition:
- Measuring surroundings: Dark room
 - Measuring temperature: Ta=25°C.
 - Adjust operating voltage to get optimum contrast at the center of the display.

Note 2:
 The definition of viewing angle:
 Refer to the graph below marked by θ and ϕ

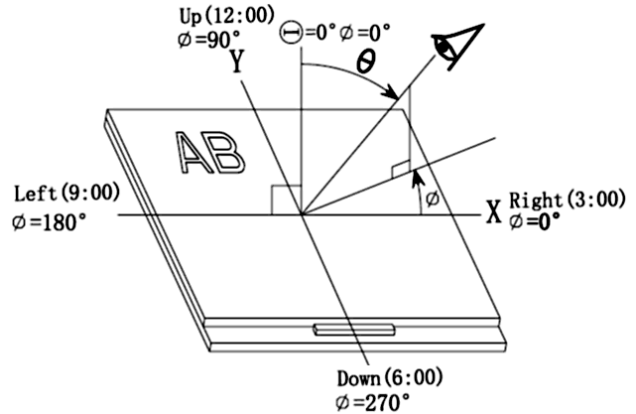

Note 3:
 The definition of contrast ratio (Test LCM using SR-3A (1°):

$$\text{Contrast Ratio (CR)} = \frac{\text{Luminance When LCD is at "White" state}}{\text{Luminance When LCD is at "Black" state}}$$
 (Contrast Ratio is measured in optimum common electrode voltage)

Note 4:
 Definition of Response time. (Test LCD using BM-7A(2°)):
 The output signals of photo detector are measured when the input signals are changed from "black" to "white" (falling time) and from "white" to "black" (rising time), respectively. The response time is defined as the time interval between the 10% and 90% of amplitudes. Refer to figure as below.

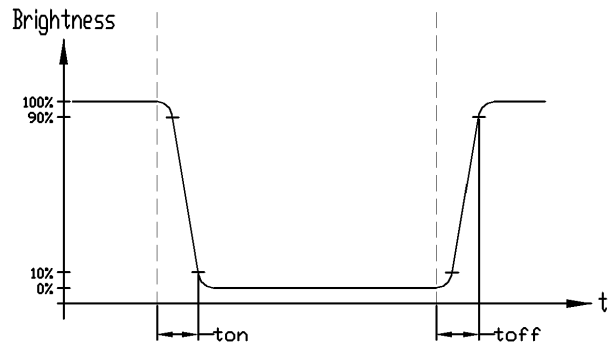

Note 5:
 Definition of Color of CIE1931 Coordinate and NTSC Ratio.

Color gamut:

$$S = \frac{\text{Area of RGB triangle}}{\text{Area of NTSC triangle}} \times 100\%$$

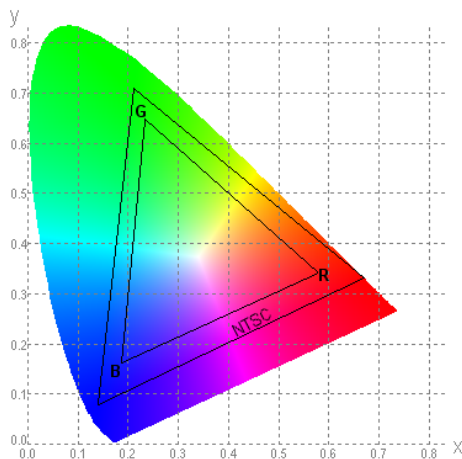

Note 6:
 The luminance uniformity is calculated by using following formula.

$$\Delta Bp = Bp (\text{Min.}) / Bp (\text{Max.}) \times 100 (\%)$$

$$Bp (\text{Max.}) = \text{Maximum brightness in 9 measured spots}$$

$$Bp (\text{Min.}) = \text{Minimum brightness in 9 measured spots.}$$

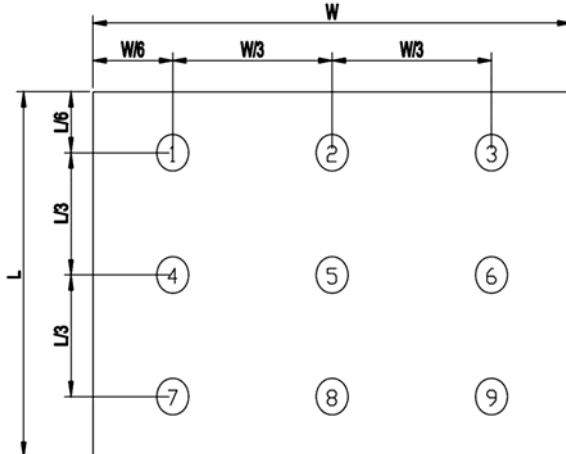

Note 7:
 Measured the luminance of white state at center point

7. Precautions of using LCD Modules

Mounting

- Mounting must use holes arranged in four corners or four sides.
- The mounting structure so provide even force on to LCD module. Uneven force (ex. Twisted stress) should not applied to the module. And the case on which a module is mounted should have sufficient strength so that external force is not transmitted directly to the module.
- It is suggested to attach a transparent protective plate to the surface in order to protect the polarizer. It should have sufficient strength in order to the resist external force.
- The housing should adopt radiation structure to satisfy the temperature specification.
- Acetic acid type and chlorine type materials for the cover case are not desirable because the former generates corrosive gas of attacking the polarizer at high temperature and the latter causes circuit break by electro-chemical reaction.
- Do not touch, push or rub the exposed polarizers with glass, tweezers or anything harder than HB pencil lead. Never rub with dust clothes with chemical treatment. Do not touch the surface of polarizer for bare hand or greasy cloth.(Some cosmetics deteriorate the polarizer.)
- When the surface becomes dusty, please wipe gently with absorbent cotton or other soft materials like chamois soaks with petroleum benzine. Normal-hexane is recommended for cleaning the adhesives used to attach front / rear polarizers. Do not use acetone, toluene and alcohol because they cause chemical damage to the polarizer.
- Wipe off saliva or water drops as soon as possible. Their long time contact with polarizer

Operating

- The spike noise causes the mis-operation of circuits. It should be within the $\pm 200\text{mV}$ level (Over and under shoot voltage)
- Response time depends on the temperature.(In lower temperature, it becomes longer.)
- Brightness depends on the temperature. (In lower temperature, it becomes lower.) And in lower temperature, response time(required time that brightness is stable after turned on) becomes longer.
- Be careful for condensation at sudden temperature change. Condensation makes damage to polarizer or electrical contacted parts. And after fading condensation, smear or spot will occur.
- When fixed patterns are displayed for a long time, remnant image is likely to occur.
- Module has high frequency circuits. Sufficient suppression to the electromagnetic interference shall be done by system manufacturers. Grounding and shielding methods may be important to minimized the interference

Electrostatic Discharge Control

Since a module is composed of electronic circuits, it is not strong to electrostatic discharge. Make certain that treatment persons are connected to ground through wrist band etc. And don't touch interface pin directly.

Strong Light Exposure

Strong light exposure causes degradation of polarizer and color filter.

Storage

When storing modules as spares for a long time, the following precautions are necessary.

- Store them in a dark place. Do not expose the module to sunlight or fluorescent light. Keep the temperature between 5°C and 35°C at normal humidity.
- The polarizer surface should not come in contact with any other object. It is recommended that they be stored in the container in which they were shipped.

Protection Film

- When the protection film is peeled off, static electricity is generated between the film and polarizer. This should be peeled off slowly and carefully by people who are electrically grounded and with well ion-blown equipment or in such a condition, etc.
- The protection film is attached to the polarizer with a small amount of glue. If some stress is applied to rub the protection film against the polarizer during the time you peel off the film, the glue is apt to be main on the polarizer. Please carefully peel off the protection film without rubbing it against the polarizer.
- When the module with protection film attached is stored for a long time, sometimes there remains a very small amount of glue still on the polarizer after the protection film is peeled off.
- You can remove the glue easily. When the glue remains on the polarizer surface or its vestige is recognized, please wipe them off with absorbent cotton waste or other soft material like chamois soaked with normal-hexane.

Transportation

The LCD modules should be no falling and violent shocking during transportation, and also should avoid excessive press, water, damp and sunshine.

8. Appendix A <Inspection items and criteria for appearance defect>

Items	Criteria			
Open Segment or Common	Not permitted			
Short	Not permitted			
Wrong Viewing Angle	Not permitted			
Decliners	Not permitted			
Contrast Ration Uneven	According to the limit specimen			
Crosstalk	According to the limit specimen			
White spots	X>1 pixel	A-area	Not permitted	Max 6 spots allowed
		B-area	Max. 1 allowed	
	1/2 pixel<X≤1 pixel	A-area	Not permitted	
		B-area	Max. 2 allowed	
	X≤1/2 pixel	A-area	Max. 1 allowed	
		B-area	Max. 4 allowed	
Black Sport	X>1 pixel	A-area	Not permitted	
		B-area	Max. 2 allowed	
	X≤1/2 pixel	A-area	Max. 1 allowed	
		B-area	Max. 4 allowed	
Line Defect	Apparent vertical horizontal line defects are not permitted			

Note:

1. On Pixel include 3 dots (RedDot + GreenDot + BlueDot)
2. Definition of Panel "A-area" and "B-area"

