



深圳市拓普微科技开发有限公司

SHENZHEN TOPWAY TECHNOLOGY CO., LTD.

LMT070DICFWD-AGB

LCD Module User Manual

Prepared by: HT LIU Date: 2016-4-5	Checked by: Date:	Approved by: Date:
---	----------------------------------	-----------------------------------

Rev.	Descriptions	Release Date
0.1	Preliminary release	2014-11-3
0.2	1、 Add button function descriptions 2、 OSD Menu function descriptions	2015-01-27
0.3	Typing correction	2016-4-5

Table of Content

1. General Specification	3
2. Block Diagram.....	3
3. Terminal Function.....	4
3.1 K1 Touch Panel Controller Terminal	4
3.2 K2 VGA Terminal	4
3.3 K3 Power Terminal.....	4
4. Absolute Maximum Ratings.....	5
5. Electrical Characteristics.....	5
5.1 Driving TFT LCD Panel	5
5.2 Driving Touch Panel.....	5
6. Functions.....	5
6.1 SW Functions.....	5
6.2 OSD Functions Descriptions	6
7. Optical Characteristics.....	6
8. Precautions of using LCD Modules	8
9. Appendix (in Chinese).....	9

1. General Specification

Signal Interface :	VGA
Display Mode :	Transmissive / Normal White
Screen Size(Diagonal) :	7.0"
Outline Dimension :	191.2 x 121.9x 22.9max (mm) (see attached drawing for details)
Active Area :	154.1 x 85.92 (mm)
Color Depth:	16.7M
Number of dots :	800 x 480
Pixel Pitch :	0.1926 x 0.1790 (mm)
Pixel Configuration :	RGB Stripe
Backlight :	LED
Surface Treatment :	Anti-Glare Treatment
Viewing Direction :	12H (*1) (gray scale inverse) 6H (*2)
Operating Temperature :	0 ~ +50°C
Storage Temperature :	-10 ~ +60°C

Note:

*1. For saturated color display content (eg. pure-red, pure-green, pure-blue or pure-colors-combinations).

*2. For "color scales" display content.

*3. Color tone may slightly change by temperature and driving condition.

2. Block Diagram

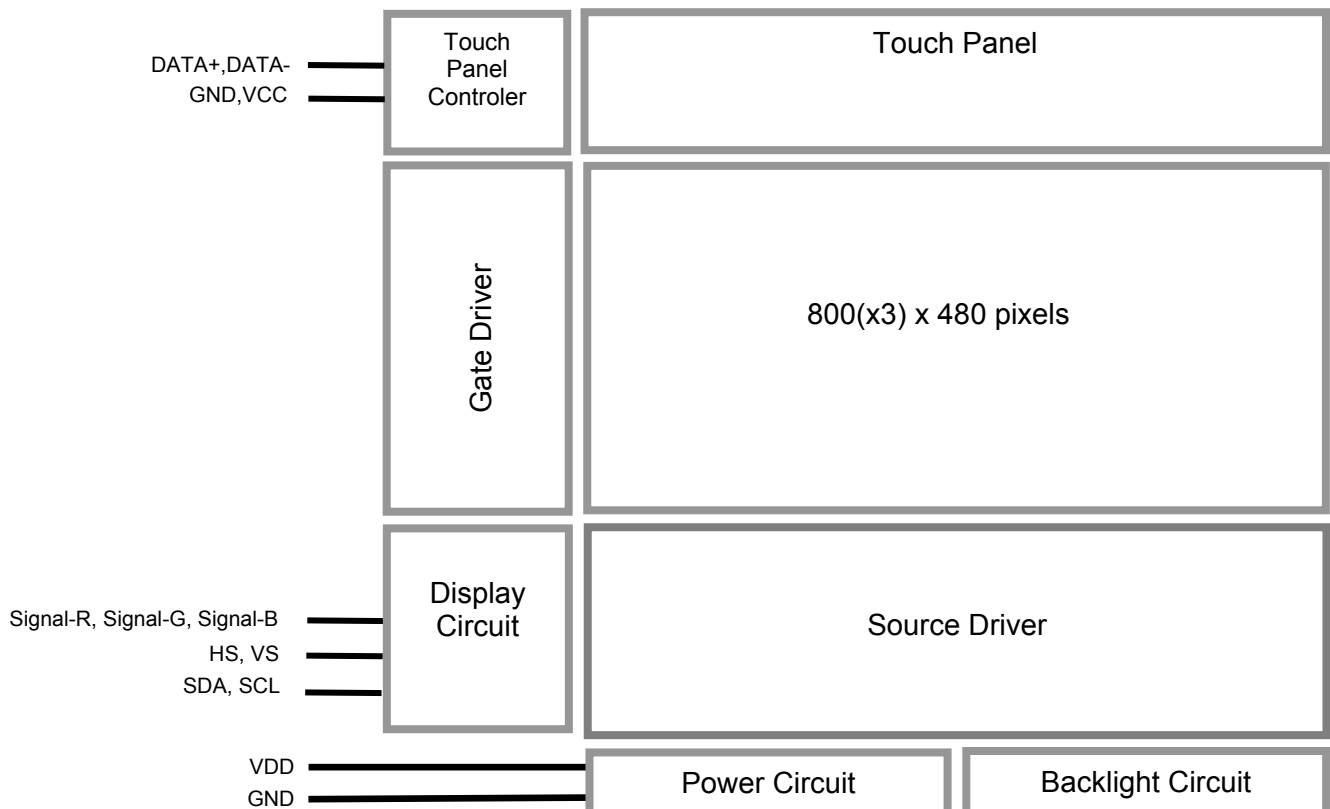

3. Terminal Function

3.1 K1 Touch Panel Controller Terminal

Pin No.	Pin Name	I/O	Descriptions
1	GND	Power	Ground
2	VCC	Power	Positive Power Supply(5.0V)
3	GND	Power	Ground
4	DATA+	I/O	USB DATA+ signal
5	DATA-	I/O	USB DATA- signal

Note:

- 1.Touch Panel power supply by USB terminal only.

3.2 K2 VGA Terminal

Pin No.	Pin Name	IO	Descriptions
1	SDA	Output	Serial data out
2	SCL	Input	Serial data clock
3	VS	Input	Analogue VGA Vertical Sync signal input
4	HS	Input	Analogue VGA Horizontal Sync signal input
5	NC	-	No connection
6	GND	Power	Signal Ground
7	Signal-B	Input	Analogue VGA Blue signal input
8	GND	Power	Signal Ground
9	Signal-G	Input	Analogue VGA Green signal input
10	GND	Power	Signal Ground
11	Signal-R	Input	Analogue VGA Red signal input

Note:

1. VGA terminal should be well connect before power on (hot-plug is not allowed).
2. Support Standard VGA Signal, from PC:
Recommend: 640x480, 60Hz , 800x480,60Hz , 800x600,60Hz

3.3 K3 Power Terminal

Pin No.	Pin Name	IO	Descriptions
1	VDD	Power	Positive Power Supply(12.0V)
2	VDD	Power	Positive Power Supply(12.0V)
3	GND	Power	Power Supply GND (0V)
4	GND	Power	Power Supply GND (0V)

4. Absolute Maximum Ratings

Top=25°C, VDD =12.0V ,GND=0V

Items	Symbol	Min.	Max.	Unit	Condition
Power Supply Voltage	VDD	-0.3	+13.0	V	
Operating Temperature	T _{OP}	0	50	°C	No Condensation
Storage Temperature	T _{ST}	-10	60	°C	No Condensation

Note:

- *1. This rating applies to all parts of the module. And should not be exceeded.
- *2. The operating temperature only guarantees operation of the circuit. The contrast, response speed, and the other specification related to electro-optical display quality is determined at the room temperature, T_{OP}=25°C.
- *3. Ambient temperature when the backlight is lit (reference value).
- *4. Any Stresses exceeding the Absolute Maximum Ratings may cause substantial damage to the device. Functional operation of this device at other conditions beyond those listed in the specification is not implied and prolonged exposure to extreme conditions may affect device reliability.

5. Electrical Characteristics

5.1 Driving TFT LCD Panel

Top=25°C, VDD =12.0V ,GND=0V

Items	Symbol	MIN.	TYP.	MAX.	Unit	Note
Supply Voltage	VDD	11.5	12.0	12.5	V	
VDD Power Consumption	I _{VDD}	-	215	-	mA	

5.2 Driving Touch Panel

Top=25°C, VCC =5.0V ,GND=0V





Items	Symbol	MIN.	TYP.	MAX.	Unit	Note
Supply Voltage	VCC	4.8	5.0	5.2	V	
Operating Current	I _{VCC}	-	21.8	-	mA	

6. Functions

6.1 SW Functions

Pin Name	Normal mode	Menu mode
SW1	Auto adjust	Select/Esc (long press)
SW2	Enter menu mode	Menu Select
SW3	Backlight -	-
SW4	Backlight +	+

6.2 OSD Functions Descriptions

Main menu	Function	Note
Color	 Brightness adjust	Using SW3/SW4 to adjust
	Contrast adjust	Using SW2 to enter menu mode to adjust
	Color temperature select	
Adjust	 Auto adjust	Using SW1 to trigger Auto adjust
	H Position adjust	Using SW2 to enter menu mode to adjust
	V Position adjust	
	Phase adjust	
	clock adjust	
OSD	 Language select	
	OSD H Position adjust	
	OSD V Position adjust	
	OSD Timeout	
	OSD Transparent	
Function	 System Reset	
	Display Ratio select	
	Sharpness adjust	

7. Optical Characteristics

Item	Symbol	Condition	MIN.	TYP.	MAX.	UNIT	Note.
Viewing angle	θ_U	(CR \geq 10)	40	50	-	degree	Note 2
	θ_D		60	70	-		
	θ_L		60	70	-		
	θ_R		60	70	-		
Contrast ratio	CR	$\theta=0^\circ$	500	600	-	-	Note 1,3
Response Time	T_{on}	25 $^\circ$ C	-	20	30	msec	Note 1,4
	T_{off}		-	-	-	msec	
Chromaticity	White	X	Backlight is on	0.260	0.310	0.360	Note 1,5
		Y		0.280	0.330	0.380	
	Red	X		0.540	0.590	0.640	
		Y		0.300	0.350	0.400	
	Green	X		0.298	0.348	0.398	
		Y		0.520	0.570	0.620	
	Blue	X		0.095	0.145	0.195	
		Y		0.060	0.110	0.160	
Luminance	L		-	250	-	cd/m ²	Note 1,6
NTSC			-	50		%	Note 5
Luminance uniformity	U		75	80	-	%	Note 1,7

Test Conditions:

1. IF= 120 mA, VF=9.2V, and the ambient temperature is 25. $^\circ$ C
2. The test systems refer to Note 1 and Note 2.

Note 1:

The data are measured after LEDs are turned on for 5 minutes. LCM displays full white. The brightness is the average value of 9 measured spots. Measurement equipment SR-3A (1°)
Measuring condition:

- Measuring surroundings: Dark room
- Measuring temperature: Ta=25°C.
- Adjust operating voltage to get optimum contrast at the center of the display.

Note 2:

The definition of viewing angle:
Refer to the graph below marked by θ and ϕ

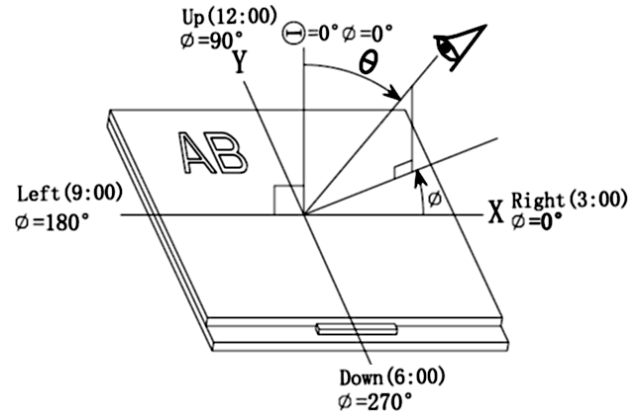

Note 3:

The definition of contrast ratio (Test LCM using SR-3A (1°)):

$$\text{Contrast Ratio (CR)} = \frac{\text{Luminance When LCD is at "White" state}}{\text{Luminance When LCD is at "Black" state}}$$

(Contrast Ratio is measured in optimum common electrode voltage)

Note 4:

Definition of Response time. (Test LCD using BM-7A(2°)):

The output signals of photo detector are measured when the input signals are changed from "black" to "white"(falling time) and from "white" to "black"(rising time), respectively. The response time is defined as the time interval between the 10% and 90% of amplitudes. Refer to figure as below.

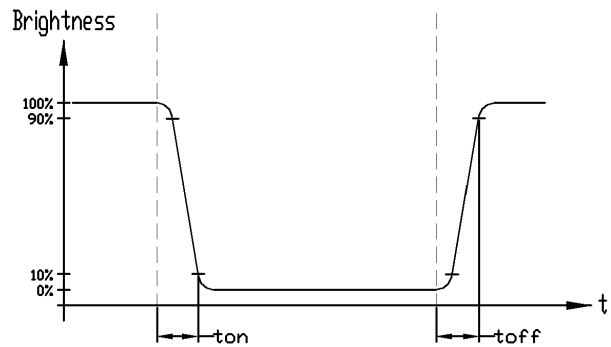

Note 5:

Definition of Color of CIE1931 Coordinate and NTSC Ratio.

Color gamut:

$$S = \frac{\text{Area of RGB triangle}}{\text{Area of NTSC triangle}} \times 100\%$$

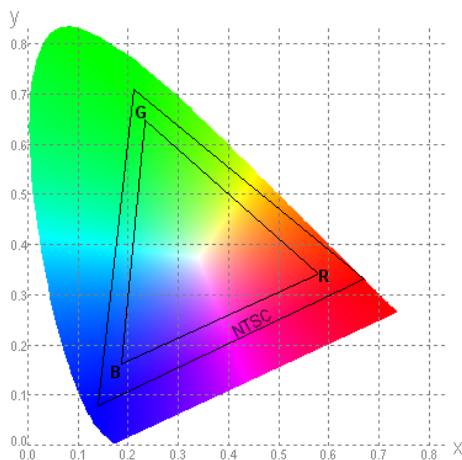

Note 6:

The luminance uniformity is calculated by using following formula.

$$\Delta Bp = Bp (\text{Min.}) / Bp (\text{Max.}) \times 100 (\%)$$

Bp (Max.) = Maximum brightness in 9 measured spots

Bp (Min.) = Minimum brightness in 9 measured spots.

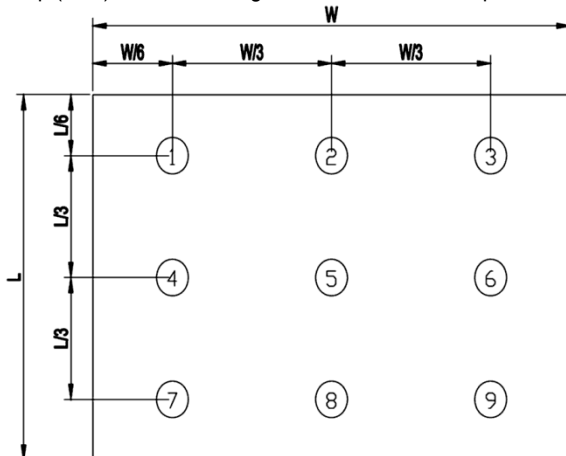

Note 7:

Measured the luminance of white state at center point

8. Precautions of using LCD Modules

Mounting

- Mounting must use holes arranged in four corners or four sides.
- The mounting structure so provide even force on to LCD module. Uneven force (ex. Twisted stress) should not applied to the module. And the case on which a module is mounted should have sufficient strength so that external force is not transmitted directly to the module.
- It is suggested to attach a transparent protective plate to the surface in order to protect the polarizer. It should have sufficient strength in order to the resist external force.
- The housing should adopt radiation structure to satisfy the temperature specification.
- Acetic acid type and chlorine type materials for the cover case are not desirable because the former generates corrosive gas of attacking the polarizer at high temperature and the latter causes circuit break by electro-chemical reaction.
- Do not touch, push or rub the exposed polarizers with glass, tweezers or anything harder than HB pencil lead. Never rub with dust clothes with chemical treatment. Do not touch the surface of polarizer for bare hand or greasy cloth.(Some cosmetics deteriorate the polarizer.)
- When the surface becomes dusty, please wipe gently with absorbent cotton or other soft materials like chamois soaks with petroleum benzine. Normal-hexane is recommended for cleaning the adhesives used to attach front / rear polarizers. Do not use acetone, toluene and alcohol because they cause chemical damage to the polarizer.
- Wipe off saliva or water drops as soon as possible. Their long time contact with polarizer

Operating

- The spike noise causes the mis-operation of circuits. It should be within the $\pm 200\text{mV}$ level (Over and under shoot voltage)
- Response time depends on the temperature.(In lower temperature, it becomes longer.)
- Brightness depends on the temperature. (In lower temperature, it becomes lower.) And in lower temperature, response time(required time that brightness is stable after turned on) becomes longer.
- Be careful for condensation at sudden temperature change. Condensation makes damage to polarizer or electrical contacted parts. And after fading condensation, smear or spot will occur.
- When fixed patterns are displayed for a long time, remnant image is likely to occur.
- Module has high frequency circuits. Sufficient suppression to the electromagnetic interference shall be done by system manufacturers. Grounding and shielding methods may be important to minimized the interference

Electrostatic Discharge Control

Since a module is composed of electronic circuits, it is not strong to electrostatic discharge. Make certain that treatment persons are connected to ground through wrist band etc. And don't touch interface pin directly.

Strong Light Exposure

Strong light exposure causes degradation of polarizer and color filter.

Storage

When storing modules as spares for a long time, the following precautions are necessary.

- Store them in a dark place. Do not expose the module to sunlight or fluorescent light. Keep the temperature between 5°C and 35°C at normal humidity.
- The polarizer surface should not come in contact with any other object. It is recommended that they be stored in the container in which they were shipped.

Protection Film

- When the protection film is peeled off, static electricity is generated between the film and polarizer. This should be peeled off slowly and carefully by people who are electrically grounded and with well ion-blown equipment or in such a condition, etc.
- The protection film is attached to the polarizer with a small amount of glue. If some stress is applied to rub the protection film against the polarizer during the time you peel off the film, the glue is apt to be main on the polarizer. Please carefully peel off the protection film without rubbing it against the polarizer.
- When the module with protection film attached is stored for a long time, sometimes there remains a very small amount of glue still on the polarizer after the protection film is peeled off.
- You can remove the glue easily. When the glue remains on the polarizer surface or its vestige is recognized, please wipe them off with absorbent cotton waste or other soft material like chamois soaked with normal-hexane.

Transportation

The LCD modules should be no falling and violent shocking during transportation, and also should avoid excessive press, water, damp and sunshine.

9. Appendix (in Chinese)

9.1、触摸屏驱动安装例

9.1.1、打开TOPWAY触摸屏驱动安装包TCB6202B Windows Universal Driver V2.4.0.306(WHQL)(for XP)



9.1.2、双击 安装驱动程序进行安装;

9.1.3、双击后出现“图一”对话框，点击“下一步”

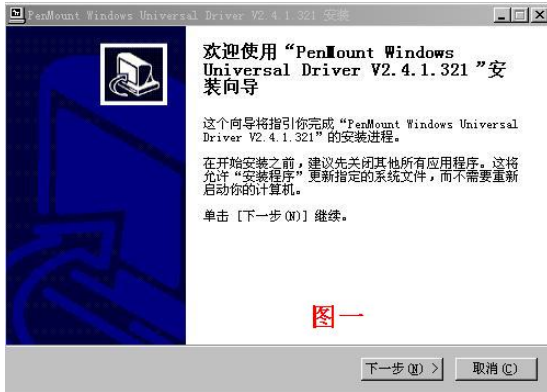

图一

9.1.4、然后出现“图二”对话框后，点击“接受”;



图二

9.1.5、然后出现“图三”对话框，点击“安装”;



图三

9.1.6、安装完成后出现“图四”对话框，选择“重启系统”，点击“完成”;



图四

9.2、触摸屏校准例



9.2.1、双击  打开触摸屏校准软件；

9.2.2、打开软件后出现“图五”对话框，白色视窗内选择触摸屏驱动，点击“设定”进行触摸屏校准；

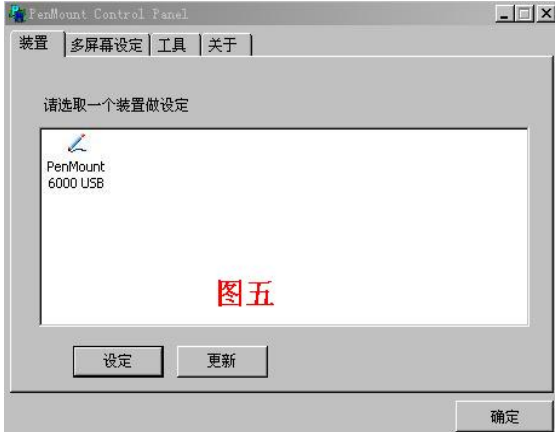

9.2.3、然后出现“图六”对话框，选择“标准位”进行触摸屏校准；



9.2.4、最后出现“图七”对话框，进入触摸屏校准界面，按照提示完成校准后自动退出图七对话框；

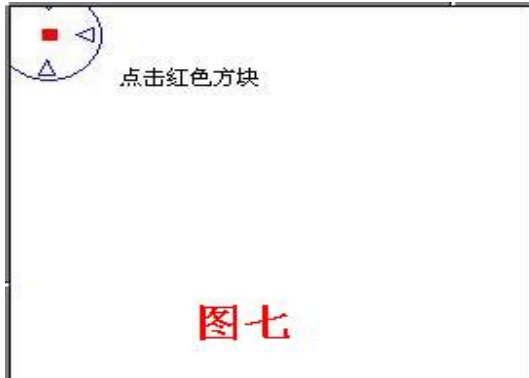

附录: Touch panel Design Precautions

1. It should prevent front case touching the touch panel Active Area (A.A.) to prevent abnormal touch.
It should left gab (e.g. 0.2~0.3mm) in between.

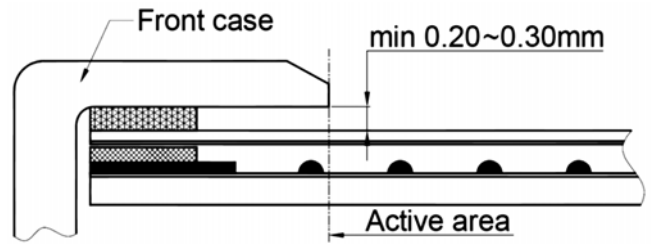

2. Outer case design should take care about the area outside the A.A.
Those areas contain circuit wires which is having different thickness. Touching those areas could deform the ITO film. As a result case the ITO cold be damaged and shorten its lifetime.
It is suggested to protect those areas with gasket (between the front case and the touch panel).
The suggested figures are $B \geq 0.50 \text{mm}$; $C \geq 0.50 \text{mm}$.

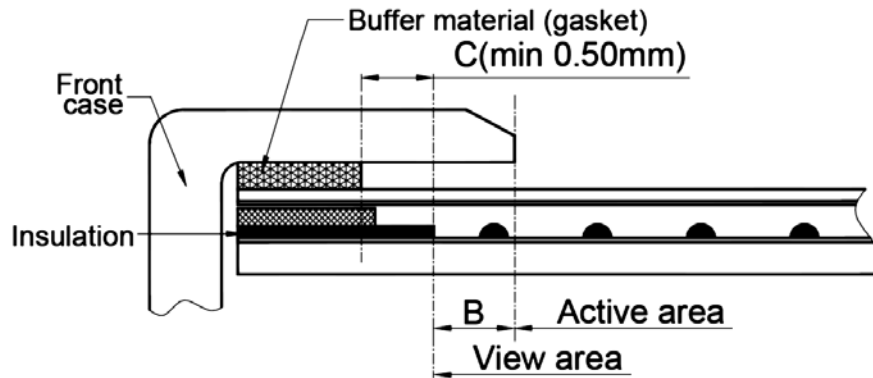

3. The front case side wall should keep space (e.g. 0.2 ~ 0.3mm) from the touch panel.

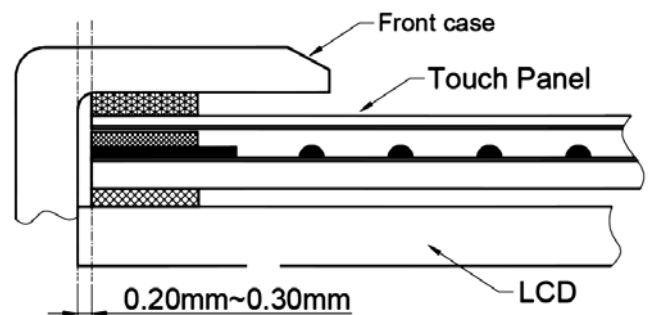

4. In general design,
touch panel V.A. should be bigger than the LCD V.A.
and touch panel A.A. should be bigger than the LCD A.A.

