



# LMT070DICFWD-AKA-1M

## LCD Module User Manual

Prepared by:  <b>PengXiaoLing</b>  Date: 2017-10-31	Checked by:    Date:	Approved by:    Date:
---	----------------------------------	-----------------------------------

Rev.	Descriptions	Release Date
0.1	Preliminary	2016-12-20
0.2	Assemble Precaution	2017-10-31

**Table of Content**

<b>1. General Specification .....</b>	<b>3</b>
<b>2. Block Diagram.....</b>	<b>3</b>
<b>3. Terminal Function.....</b>	<b>4</b>
3.1 K1 Terminal(DVI Right angle connector).....	4
3.2 K3 Terminal.....	4
<b>4. Absolute Maximum Ratings .....</b>	<b>5</b>
<b>5. Electrical Characteristics .....</b>	<b>5</b>
5.1 DC Characteristics .....	5
5.2 DC Characteristics(LVDS) .....	5
5.3 POWER ON/OFF SEQUENCE .....	6
<b>6. AC Characteristics .....</b>	<b>7</b>
6.1 AC Characteristics(LVDS).....	7
6.2 AC Characteristics(TFT) .....	8
<b>7. Optical Characteristics .....</b>	<b>9</b>
<b>8. Precautions for Use of LCD Modules .....</b>	<b>10</b>
8.1 Handling Precautions .....	10
8.2 Storage precautions .....	10
8.3 Transportation Precautions .....	10
<b>9. Assemble Precaution .....</b>	<b>11</b>

**1. General Specification**

Signal Interface :	LVDS (JEIDA 24 bits)
Display Mode :	Transmissive with Normally White
Screen Size :	7.0 inch
Outline Dimension :	208.6 x 133.6 x 30.0(mm)(with mounting Bezel) (see outline drawing for details)
Active Area :	154.08x 85.92(mm)
Number of dots :	800x 3 (RGB) x 480
Dot Pitch :	0.1926x 0.179(mm)
Pixel Configuration :	R.G.B. Vertical Stripe
Backlight :	White LED
Viewing Direction :	6 o'clock ( Gray scale Inversion ) (*1) 12 o'clock (*2)
Operating Temperature :	-35 ~ +70°C
Storage Temperature :	-30 ~ +80°C

Note:

- \*1. For saturated color display content (eg. pure-red, pure-green, pure-blue or pure-colors -combinations).
- \*2. For “color scales” display content.
- \*3. Color tone may slightly change by temperature and driving condition.

**2. Block Diagram**

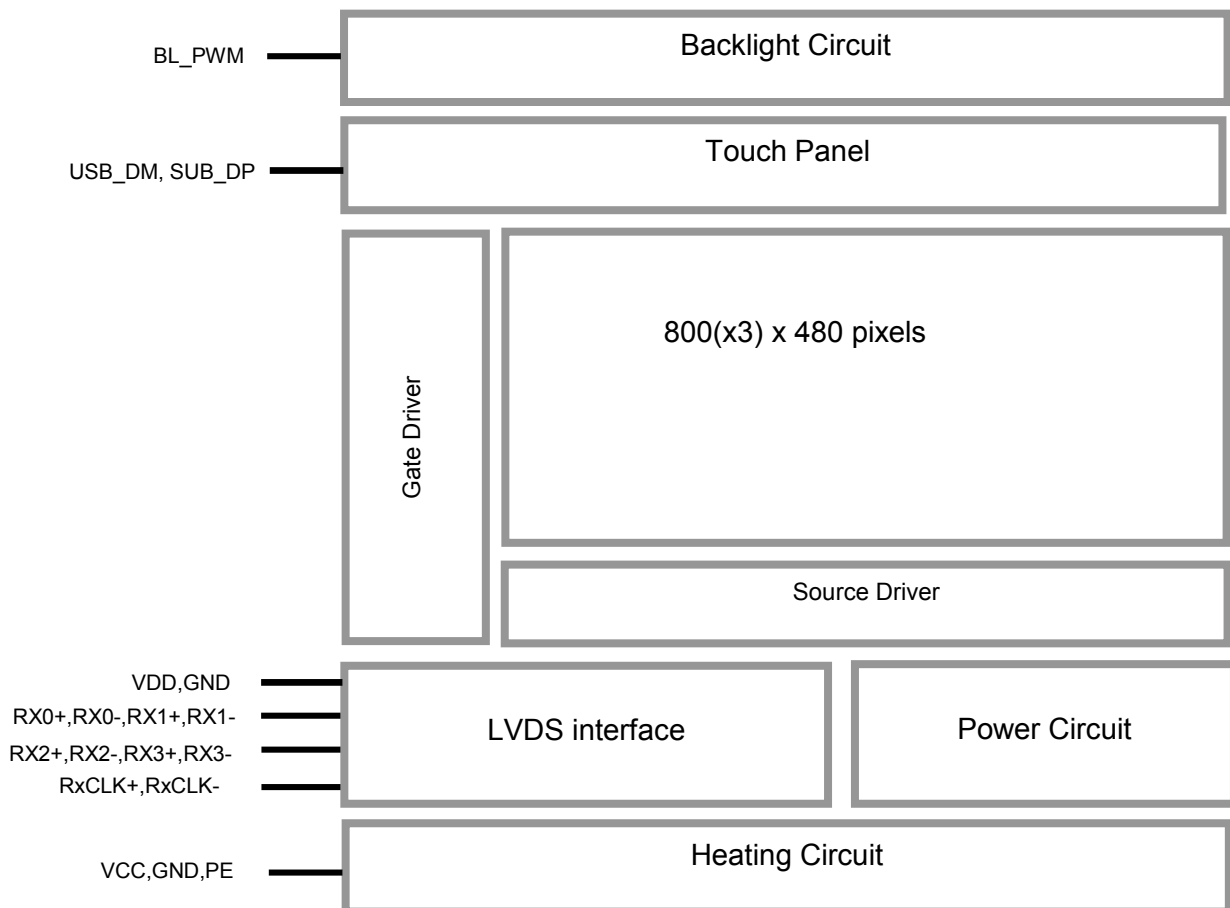

### 3. Terminal Function

#### 3.1 K1 Terminal(DVI Right angle connector)

Pin No.	Pin Name	IO	Descriptions
1	RX2-	Input	LVDS receiver negative signal channel 2
2	RX2+	Input	LVDS receiver positive signal channel 2
3	GND	Power	Ground
4	BL_PWM	Input	Backlight dimming control(High actives) PWM may be used to adjust the output brightness
5	NC	-	No connection
6	VDD	Power	Positive Power Supply(5.0V)
7	VDD	Power	Positive Power Supply(5.0V)
8	VDD	Power	Positive Power Supply(5.0V)
9	RX1-	Input	LVDS receiver negative signal channel 1
10	RX1+	Input	LVDS receiver positive signal channel 1
11	GND	Power	Ground
12	RX3-	Input	LVDS receiver negative signal channel 3
13	RX3+	Input	LVDS receiver positive signal channel 3
14	VDD	Power	Positive Power Supply(5.0V)
15	GND	Power	Ground
16	GND	Power	Ground
17	RX0-	Input	LVDS receiver negative signal channel 0
18	RX0+	Input	LVDS receiver positive signal channel 0
19	GND	Power	Ground
20	USB_DM	I/O	USB D- signal
21	USB_DP	I/O	USB D+ signal
22	GND	Power	Ground
23	RXCLK+	Input	LVDS receiver positive signal clock
24	RXCLK-	Input	LVDS receiver negative signal clock
25	VDD	Power	Positive Power Supply(5.0V)
26	VDD	Power	Positive Power Supply(5.0V)
27	NC	-	No connection
28	NC	-	No connection
29	GND	Power	Ground
--	SHELL	--	Case Ground

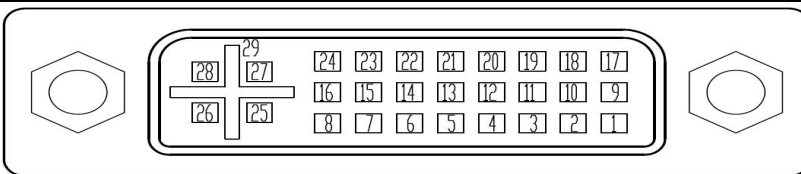

#### 3.2 K3 Terminal

Pin No.	Pin Name	IO	Descriptions
1	VCC	Power	Positive Power Supply(12.0V)
2	GND	Power	Ground
3	PE	--	Case Ground

### 4. Absolute Maximum Ratings

Items	Symbol	Min.	Max.	Unit	Condition
Power Supply voltage	VDD	-0.3	5.5	V	
Heating Supply voltage	VCC	-0.3	12.5	V	
Operating Temperature	T <sub>OP</sub>	-35	70	°C	No Condensation
Storage Temperature	T <sub>ST</sub>	-30	80	°C	No Condensation

Note:

- \*1. This rating applies to all parts of the module. And should not be exceeded.
- \*2. The operating temperature only guarantees operation of the circuit. The contrast, response speed, and the other specification related to electro-optical display quality is determined at the room temperature, T<sub>OP</sub>=25°C
- \*3. Any Stresses exceeding the Absolute Maximum Ratings may cause substantial damage to the device. Functional operation of this device at other conditions beyond those listed in the specification is not implied and prolonged exposure to extreme conditions may affect device reliability.

### 5. Electrical Characteristics

#### 5.1 DC Characteristics

VDD=5.0V, VCC=12.0V, GND=0V, T<sub>a</sub>=25°C

Items	Symbol	MIN.	TYP.	MAX.	Unit	Note
Power Supply Voltage	VDD	4.7	5.0	5.3	V	
Heating Supply Voltage	VCC	11.7	12.0	12.3	V	
Power Supply Consumption	I <sub>dd</sub>	--	500	TBD	mA	*1
Heating Supply Consumption	I <sub>CC</sub>	--	1.65	TBD	A	
Input High Voltage	V <sub>IH</sub>	3.0	3.3	-	V	BL_PWM
Input Low Voltage	V <sub>IL</sub>	GND	-	0.3	V	BL_PWM

Note1:

- \*1. BL\_PWM=Hi;
- \*2. Recommended BL\_PWM PWM Freq. is 3kHz.

\*3. Terminal circuit.

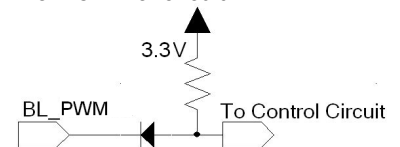

#### 5.2 DC Characteristics(LVDS)

VDD=5.0V, GND=0V, T<sub>a</sub>=25°C

Items	Symbol	MIN.	TYP.	MAX.	Unit	Note
Differential Input High Threshold	V <sub>TH</sub>	-	-	100	mV	
Differential Input Low Threshold	V <sub>TL</sub>	-100	-	-	mV	
Input Current	I <sub>IN</sub>			± 10	uA	
Differential Input common Mode voltage	V <sub>CMLVDS</sub>	1.65	-	2.1	V	

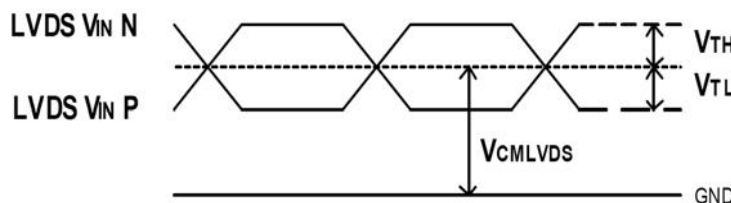

LVDS DC timing diagram

**5.3 POWER ON/OFF SEQUENCE**

Parameter	Symbol	MIN.	TYP.	MAX.	Unit	Note
VDD 5.0V to signal starting	Tp1	0	-	50	ms	
Signal starting to backlight on	Tp2	150	-	-	ms	
Signal off to VDD 3.0V	Tp3	0	-	50	ms	
Backlight off to signal off	Tp4	150	-	-	ms	

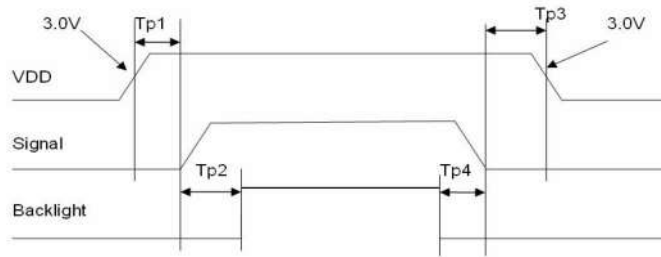

**Interface Power On/Off Sequence**

## 6. AC Characteristics

### 6.1 AC Characteristics(LVDS)

VDD=5.0V,GND=0V,T<sub>a</sub>=25°C

Item	Symbol	MIN.	TYP.	MAX.	Unit	Condition
Input CLK period	t <sub>RI</sub> CLK	8.9	-	50	ns	
Input Data Position 0 ( t <sub>RI</sub> CLK = 8.9ns )	t <sub>RI</sub> 0	-0.3	-	+0.3	ns	
Input Data Position 1 (t <sub>RI</sub> CLK = 8.9ns )	t <sub>RI</sub> 1	t <sub>RI</sub> CLK/7-0.3	t <sub>RI</sub> CLK/7	t <sub>RI</sub> CLK/7+0.3	ns	
Input Data Position 2 (t <sub>RI</sub> CLK = 8.9ns )	t <sub>RI</sub> 2	2t <sub>RI</sub> CLK/7-0.3	2t <sub>RI</sub> CLK/7	2t <sub>RI</sub> CLK/7+0.3	ns	
Input Data Position 3 (t <sub>RI</sub> CLK = 8.9ns )	t <sub>RI</sub> 3	3t <sub>RI</sub> CLK/7-0.3	3t <sub>RI</sub> CLK/7	3t <sub>RI</sub> CLK/7+0.3	ns	
Input Data Position 4 (t <sub>RI</sub> CLK = 8.9ns )	t <sub>RI</sub> 4	4t <sub>RI</sub> CLK/7-0.3	4t <sub>RI</sub> CLK/7	4t <sub>RI</sub> CLK/7+0.3	ns	
Input Data Position 5 (t <sub>RI</sub> CLK = 8.9ns )	t <sub>RI</sub> 5	5t <sub>RI</sub> CLK/7-0.3	5t <sub>RI</sub> CLK/7	5t <sub>RI</sub> CLK/7+0.3	ns	
Input Data Position 6 (t <sub>RI</sub> CLK = 8.9ns )	t <sub>RI</sub> 6	6t <sub>RI</sub> CLK/7-0.3	6t <sub>RI</sub> CLK/7	6t <sub>RI</sub> CLK/7+0.3	ns	

#### Input Clock and Data timing Diagram:

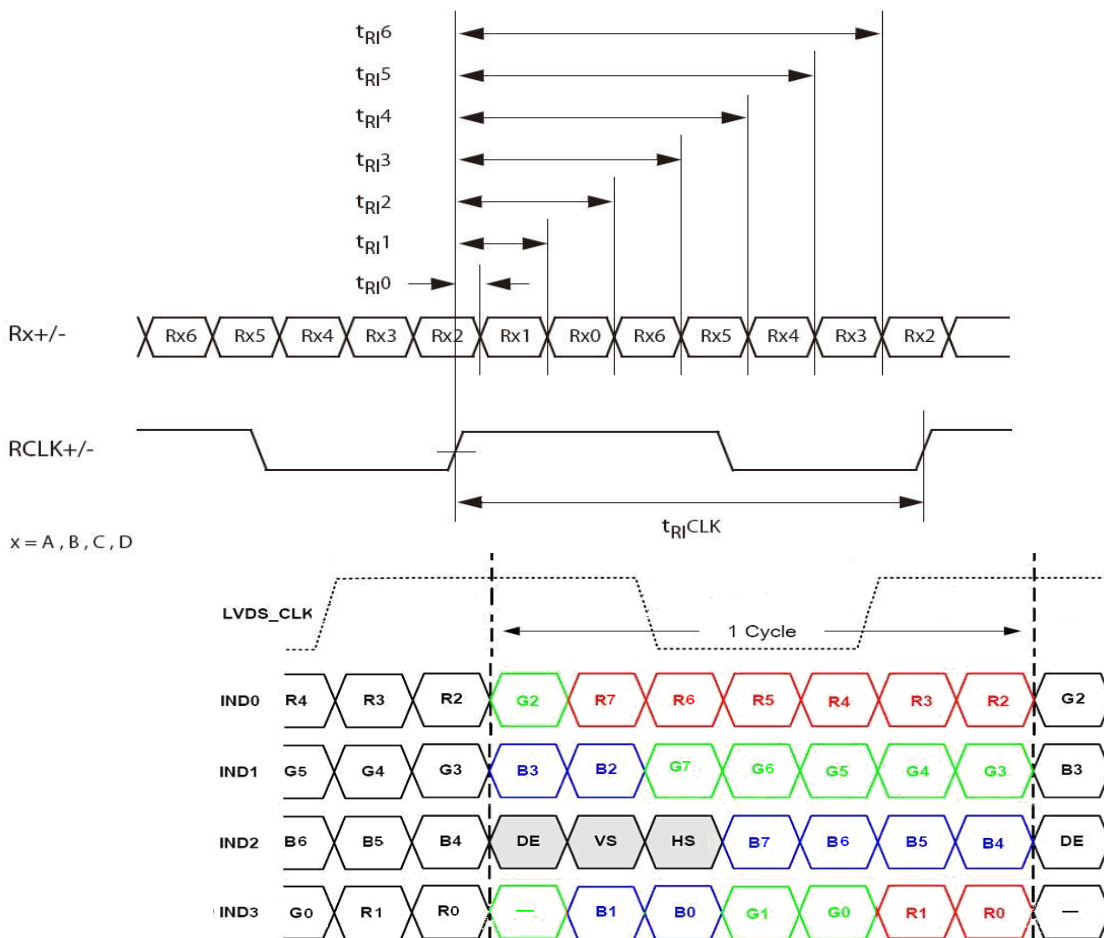

**6.2 AC Characteristics(TFT)**

Item	Symbol	MIN.	TYP.	MAX.	Unit	Remark
Horizontal Display Area	thd	-	800	-	DCLK	
DCLK Frequency	fclk	26.4	33.3	46.8	MHz	
One Horizontal Line	th	862	1056	1200	DCLK	
HS pulse width	thpw	1	-	40	DCLK	
HS Blanking	thb	46	46	46	DCLK	
HS Front Porch	thfp	16	210	354	DCLK	

Item	Symbol	Values			Unit	Remark
		MIN.	TYP.	MAX.		
Vertical Display Area	tvd	-	480	-	TH	
VS period time	tv	510	525	650	TH	
VS pulse width	tvpw	1	-	20	TH	
VS Blanking	tvb	23	23	23	TH	
VS Front Porch	tvfp	7	22	147	TH	



**1 Horizontal input timing diagram.**

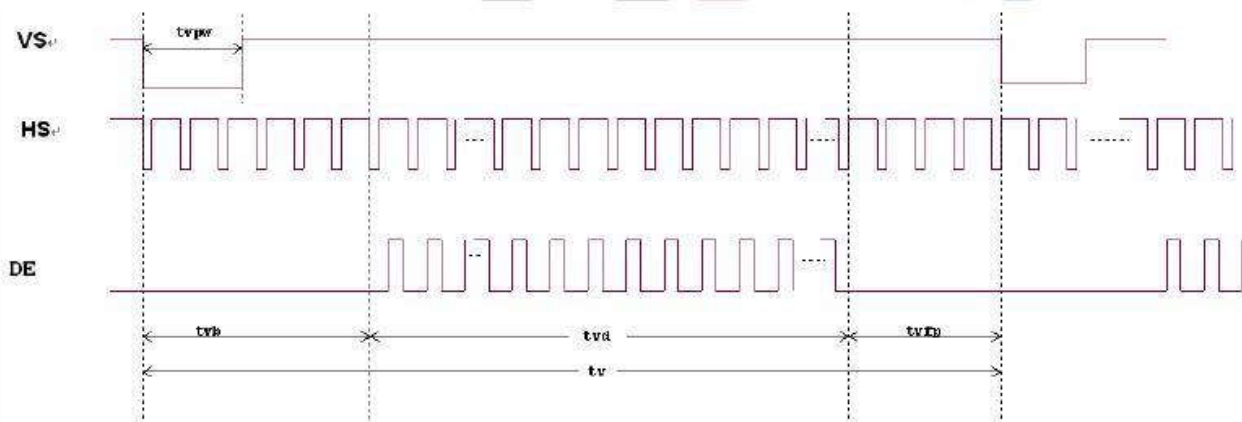

**Vertical input timing diagram.**



**7. Optical Characteristics**

Item	Symbol	Condition	MIN.	TYP.	MAX.	UNIT	Note.
Viewing angle (CR ≥ 10)	$\theta_L$	9 o'clock	60	70	-	degree	*2
	$\theta_R$	3 o'clock	60	70	-		
	$\theta_T$	12 o'clock	40	50	-		
	$\theta_B$	6 o'clock	60	70	-		
Response Time	$T_f$	Normal $\theta=0^\circ$	-	10	20	msec	*3
	$T_r$		-	15	30	msec	
Contrast ratio	CR		400	500	-	-	*1
Color chromaticlty	$W_X$		0.26	0.31	0.26	-	
	$W_Y$		0.28	0.33	0.38	-	
Luminance	L		-	500	-	cd/m <sup>2</sup>	*4
Luminance uniformity	$Y_U$		70	75	-	%	*4

Note:

\*1. Definition of Contrast Ratio

The contrast ratio could be calculate by the following expression:

Contrast Ratio (CR) = Luminanc with all pixels white / Luminance with all pixels black

\*2 Definition of Viewing Angle

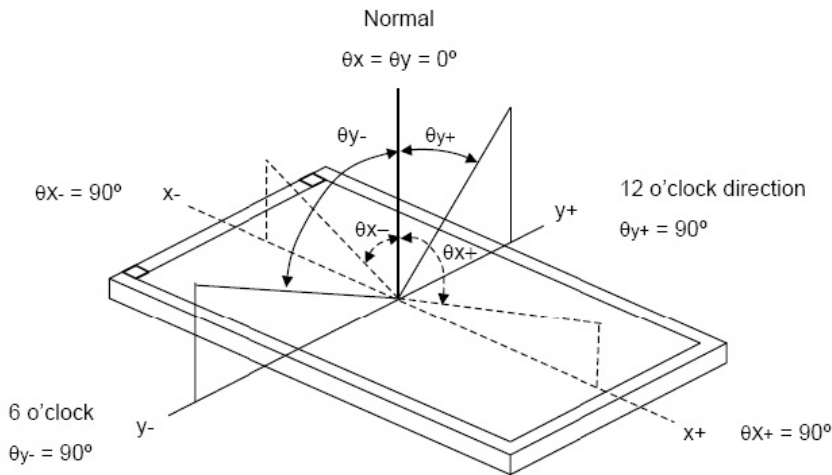

\*3 Definition of response time

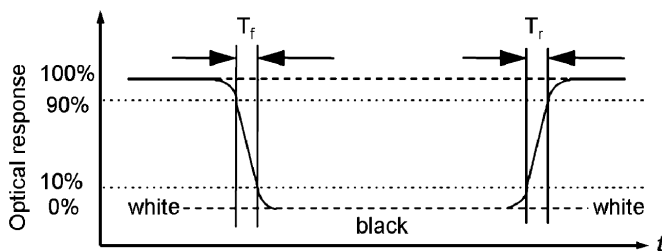

\*4 Definition of Luminance Uniformity

Luminance uniformity (Lu)=

Min. Luminance form pt1~pt9 / Max Luminance form Pt1~pt9

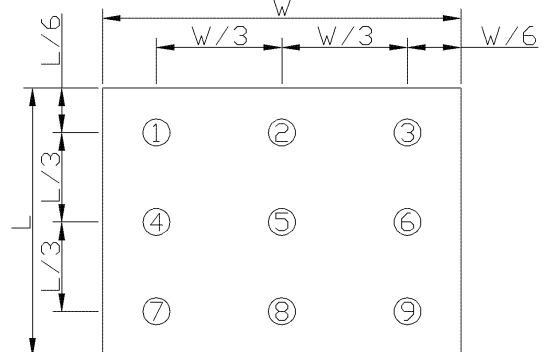

## 8. Precautions for Use of LCD Modules

### 8.1 Handling Precautions

- 8.1.1 The display panel is made of glass. Do not subject it to a mechanical shock by dropping it from a high place, etc.
- 8.1.2 If the display panel is damaged and the liquid crystal substance inside it leaks out, be sure not to get any in your mouth, if the substance comes into contact with your skin or clothes, promptly wash it off using soap and water.
- 8.1.3 Do not apply excessive force to the display surface or the adjoining areas since this may cause the color tone to vary.
- 8.1.4 The polarizer covering the display surface of the LCD module is soft and easily scratched. Handle this polarizer carefully.
- 8.1.5 If the display surface is contaminated, breathe on the surface and gently wipe it with a soft dry cloth. If still not completely clear, moisten cloth with one of the following solvents:
  - Isopropyl alcohol
  - Ethyl alcoholSolvents other than those mentioned above may damage the polarizer. Especially, do not use the following:
  - Water
  - Ketone
  - Aromatic solvents
- 8.1.6 Do not attempt to disassemble the LCD Module.
- 8.1.7 If the logic circuit power is off, do not apply the input signals.
- 8.1.8 To prevent destruction of the elements by static electricity, be careful to maintain an optimum work environment.
  - 8.1.8.1 Be sure to ground the body when handling the LCD Modules.
  - 8.1.8.2 Tools required for assembly, such as soldering irons, must be properly ground.
  - 8.1.8.3 To reduce the amount of static electricity generated, do not conduct assembly and other work under dry conditions.
  - 8.1.8.4 The LCD Module is coated with a film to protect the display surface. Be care when peeling off this protective film since static electricity may be generated.

### 8.2 Storage precautions

- 8.2.1 When storing the LCD modules, avoid exposure to direct sunlight or to the light of fluorescent lamps.
- 8.2.2 The LCD modules should be stored under the storage temperature range. If the LCD modules will be stored for a long time, the recommend condition is:  
Temperature : 0°C ~ 40°C Relatively humidity: ≤80%
- 8.2.3 The LCD modules should be stored in the room without acid, alkali and harmful gas.

### 8.3 Transportation Precautions

The LCD modules should be no falling and violent shocking during transportation, and also should avoid excessive press, water, damp and sunshine.

## 9. Assemble Precaution

### 安装注意事项

- Customer front panel opening and thickness for TOPWAY display module should be fit for its assembling and sealing.
  - The suggested assemble gap(A) should be about 0.3~0.5mm on each side.
  - The suggested front panel thickness(B) should be about 1.5~4.0mm.

客户面板开窗及厚度应适合 TOPWAY 显示模块的安装及密封。

- 建议每边安装间隙(A)约为 0.3 ~0.5mm.
- 建议面板厚度(B) 约为 1.5~4.0mm.

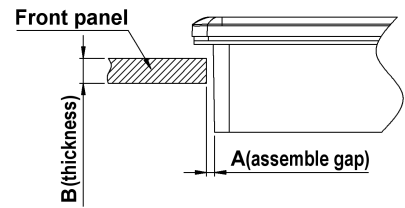

- A silicon sealing ring ships with TOPWAY display module. It should be in place before assembling to the front panel. TOPWAY 显示模块上的硅胶密封圈在安装时确保嵌入到位。

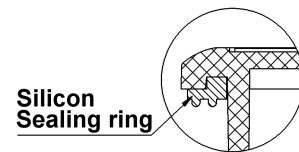

- It should fix the TOPWAY display module into the front panel with two steps.
  - Pre-fixing: Slightly tighten the screws on beam clamp in sequence as picture on the right side.
  - Final-fixing: Tighten the fixing screws on beam clamp in sequence as well with twist torque about 8~10kg.cm (\*1) . and put the beam clamp straight.

Note:

\*1. Over tightening might damage the shell and cause bad sealing result.

应分两步将 TOPWAY 显示模块固定在面板上。

- 预紧: 将卡扣螺钉按右图所示顺序稍加预紧.
- 紧定:再次按顺序用 **8~10kg.cm** 扭力拧紧卡扣螺钉(\*1),并注意卡扣置正无歪斜.

注:

\*1. 过度拧紧可能会损坏外壳和影响密封效果.

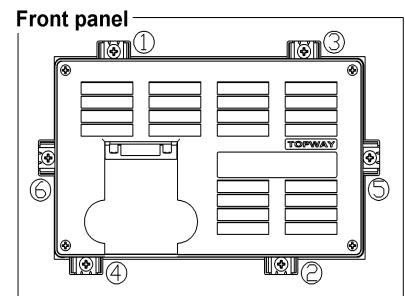

- It is strongly suggested to check the seal balancing of the four-side of the TOPWAY display module.
  - The suggested after assemble sealed gap(C) should be about 1.0~1.5mm.

需注意检查 TOPWAY 显示模块四周在安装后保证平衡密封。

- 建议组装后的密封间隙(C)约为 1.0 ~1.5 mm.

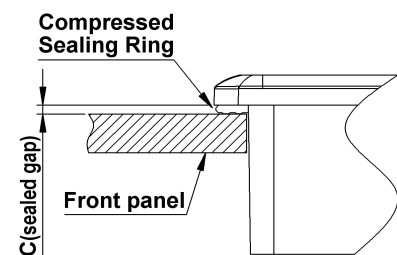

- Others:
  - Never hot plug the device! Power off the device before connect or disconnect the display module.
  - Don't forget to remove the cover protective film for normal operation.

其它:

- 视频线禁止带电插拔! 在连接或断开显示模块之前先关闭设备电源.
- 使用前请揭去保护膜.