



深圳市拓普微科技开发有限公司

SHENZHEN TOPWAY TECHNOLOGY CO., LTD.

# LMT070DICFWD-NBA

## LCD Module User Manual

Prepared by:  <b>K.C.</b>  Date: 2012-03-05	Checked by:    Date:	Approved by:    Date:
---	----------------------------------	-----------------------------------

Rev.	Descriptions	Release Date
0.1	Preliminary release	2011-06-10
0.2	Typing Correction on Section 4	2011-09-26
0.3	Add draw 8dot memory mapping	2011-12-28
0.4	Update I <sub>DD BL</sub> & "set_func" description	2012-03-05

**Table of Content**

<b>1. Product Highlight</b> .....	<b>3</b>
<b>2. General Specification</b> .....	<b>3</b>
<b>3. Block Diagram</b> .....	<b>3</b>
<b>4. Terminal Function (Input Terminal)</b> .....	<b>4</b>
<b>5. Absolute Maximum Ratings</b> .....	<b>5</b>
<b>6. Electrical Characteristics</b> .....	<b>5</b>
6.1 DC Characteristics .....	5
<b>7. AC Characteristics</b> .....	<b>6</b>
7.1 Timing Characteristics.....	6
<b>8. Optical Characteristics</b> .....	<b>7</b>
<b>9. Function Specifications</b> .....	<b>8</b>
9.1 Touch Panel Controller Functions .....	8
9.2 TFT Controller Functions .....	9
<b>10. Precautions of using LCD Modules</b> .....	<b>11</b>
<b>11. Appendix &lt;Inspection items and criteria for appearance defect&gt;</b> .....	<b>12</b>

### 1. Product Highlight

- Power Supply and logic level
  - 3.3V logic supply
  - 3.3V logic level
  - 5.0V backlight supply
- Display
  - TFT LCD display
  - 800 x 480 pixels
  - 65536colors,
  - data refresh rate up to 20fps
- Host Interface
  - 16bit data, 1bit address, 8080mode
  - fast command execution
- Built-in Drawing Engine
  - Fill Windows
  - Fill Pixel
  - Draw Pixel
  - Draw Box (filled)
  - Draw 8Pixels (2 color)
  - Draw 8Pixels (transparence)
  - Clear Screen
  - Address auto increment
- Backlight Control
  - 16 level PWM for backlight control
- Touch Panel
  - Resistive Touch Panel
  - Built in Touch Panel Controller

### 2. General Specification

Signal Interface :	16bit data, 1bit address
Display Technology :	a-Si TFT active matrix
Display Mode :	Transmissive / Normal White
Screen Size(Diagonal) :	7.0"
Outline Dimension :	190.0 x 112.0 x 13.3 (mm) (see attached drawing for details)
Active Area :	154.08 x 85.92 (mm)
Number of dots :	800 x 3 (RGB) x 480
Pixel Pitch :	0.0642 x 0.179 (mm)
Pixel Configuration :	RGB Stripe
Backlight :	LED
Color Depth:	65536(16bit)colors
Surface Treatment :	Anti-Glare Treatment
Viewing Direction :	6 o'clock
Operating Temperature :	-20 ~ +70°C
Storage Temperature :	-30 ~ +80°C

### 3. Block Diagram

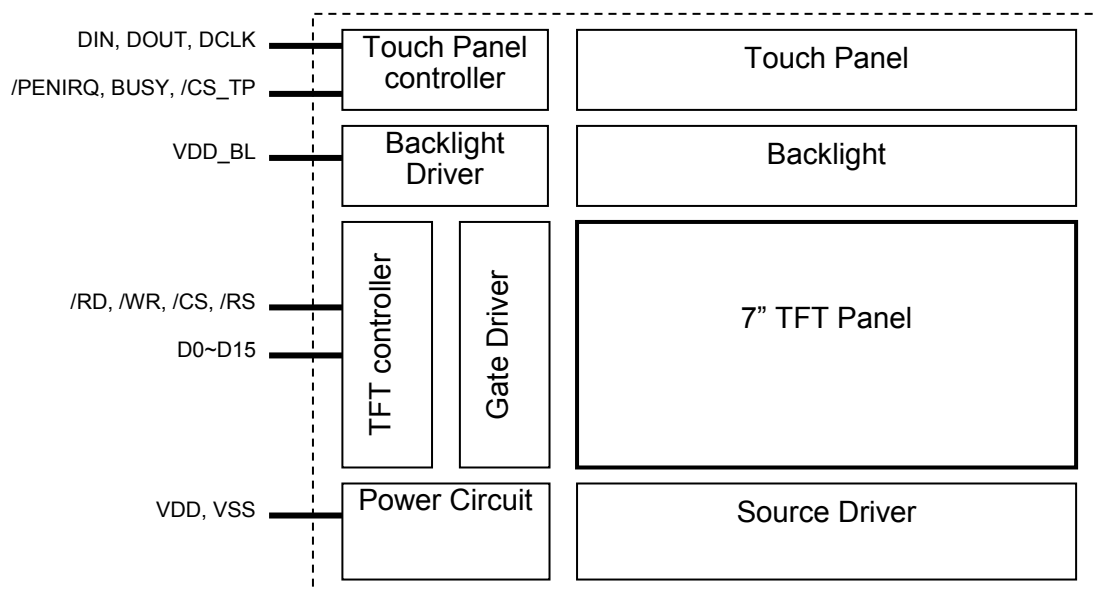

**4. Terminal Function (Input Terminal)**

No.	Pin Name	I/O	Descriptions (TFT controller)	Descriptions (TP controller)
1	VDD_BL	P	Positive Power Supply for Backlight Driving (5.0V)	
2				
3	VDD	I	Positive Power Supply (3.3V)	
4				
5	VSS	P	Power Supply GND (0V)	
6				
7	/WR	I	Write signal	--
8	/RD	I	Read Status signal	
9	/CS	I	Chip Select signal	--
10	RS	I	Register Select	--
			RS=0, command or op-code RS=1, data or parameter	
				--
11	D15	I/O	16bit Data bus	
:	:			
26	D0			
27	VSS	P	Power Supply GND (0V)	
28				
29	/PENIRQ	I	--	Pen Interrupt (*1)
30	DOUT	O	--	Data Output
31	BUSY	O	--	Busy Output
32	DIN	I	--	Data Input
33	/CS_TP	I	--	Chip Select, also for initiating the conversions
34	DCLK	I	--	Clock Input for Serial Data & conversions
35	VSS	P	Power Supply GND (0V)	
36				

Note.

\*1. Pulled-up by internal resistor

## 5. Absolute Maximum Ratings

Items	Symbol	Min.	Max.	Unit	Condition
Power Supply voltage	V <sub>DD</sub>	-0.3	4.0	V	
Backlight Supply voltage	V <sub>DD_BL</sub>	-0.3	6.0	V	
Operating Temperature	T <sub>OP</sub>	-20	70	°C	No Condensation
Storage Temperature	T <sub>ST</sub>	-30	80	°C	No Condensation

Note:

- \*1. This rating applies to all parts of the module. And should not be exceeded.
- \*2. The operating temperature only guarantees operation of the circuit. The contrast, response speed, and the other specification related to electro-optical display quality is determined at the room temperature, T<sub>OP</sub>=25°C
- \*3. Ambient temperature when the backlight is lit (reference value)
- \*4. Any Stresses exceeding the Absolute Maximum Ratings may cause substantial damage to the device. Functional operation of this device at other conditions beyond those listed in the specification is not implied and prolonged exposure to extreme conditions may affect device reliability.

## 6. Electrical Characteristics

### 6.1 DC Characteristics

Top=25°C, V<sub>SS</sub>=0V

Items	Symbol	Min.	Typ.	Max.	Unit	Remark
Power Supply Voltage	V <sub>DD</sub>	3.1	3.3	3.5	V	*2
Backlight Supply Voltage	V <sub>DD_BL</sub>	4.5	5.0	5.5	V	
Input logic high voltage	V <sub>IH</sub>	0.8V <sub>DD</sub>	-	V <sub>DD</sub>	V	*2, *3
Input logic low voltage	V <sub>IL</sub>	0	-	0.2V <sub>DD</sub>	V	*2, *3
Logic Supply Current (VDD)	I <sub>DD</sub>	-	128.0	350	mA	
Backlight Supply Current (VDD_BL)	I <sub>DD_BL</sub>	-	230.0	600.0	mA	Backlight (100%PWM)
		-	150.0	-		Backlight (66%PWM)

Note:

- \*1. Never Apply logic signal before the VDD and VDD\_BL supply.
- \*2. VDD setting should match the signals voltage
- \*3. For all the inputs signals
- \*4. Clock Freq=66MHz

### 6.2 Touch panel Characteristics

T<sub>OP</sub> =25°C

Items	Symbol	MIN.	TYP.	MAX.	Unit	Applicable Pin
Operating Force	Fop	100	-	160	g	-
Life Time	TL	-	1,000,000	-	times	-

Cautions:

Exceeding the recommended Condition could cause substantial damage to the touch panel and shorten its lifetime.

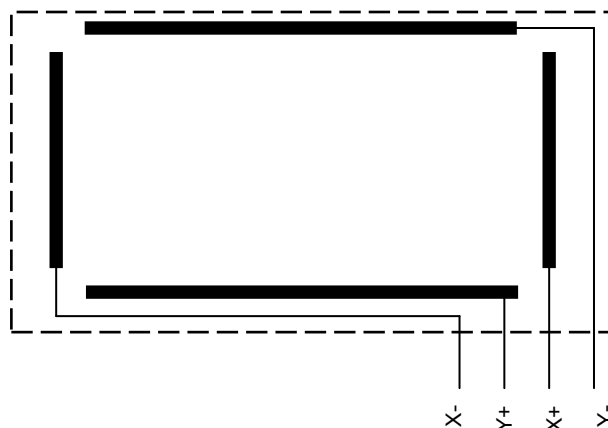

## 7. AC Characteristics

### 7.1 Timing Characteristics

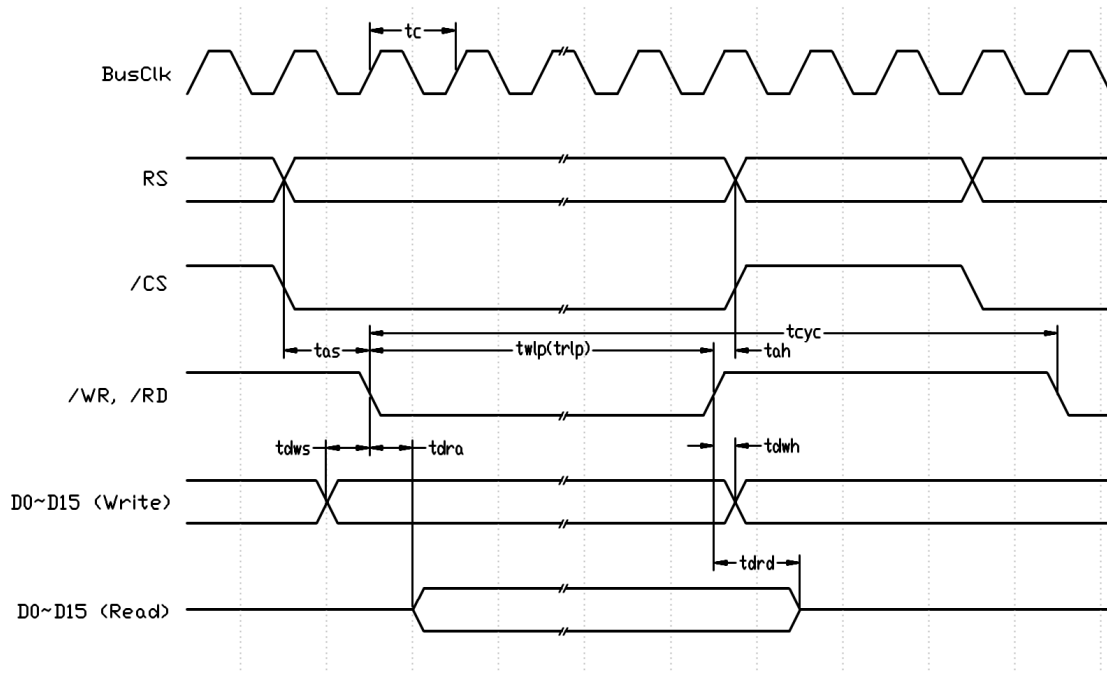

**8080 Mode System Bus Timing**

$V_{SS}=0V, V_{DD}=3.3V, T_{OP}=25^{\circ}C$

Item	Symbol	MIN.	TYP.	MAX.	Unit
Bus Clock frequency	fbclk	-	66.0	-	MHz
Cycle time	tcyc	9 tc	-	-	ns
Address setup time (*4)	tas	1.5 tc	-	-	ns
Address hold time	tah	0	-	-	ns
/WR LOW pulse width	twlp	4 tc	-	-	ns
/RD LOW pulse width	trlp	2 tc	-	-	ns
Data write setup time	tdws	0	-	-	ns
Data write hold time	tdwh	0	-	-	ns
Data read access time	tdra	0	-	0.5 tc	ns
Data read disable time	tdrd	0	-	0.5 tc	ns

Note:

- \*1.  $tc=1/fbclk$
- \*2. Input signal rise/fall time should be less than 15ns
- \*3. All timing is using 20% and 80% of VDD as the reference
- \*4. /CS must be active before the read or write access

### 8. Optical Characteristics

Item	Symbol	Condition	MIN.	TYP.	MAX.	UNIT	Note.
Viewing angle (CR ≥ 10)	$\theta_L$	9 o'clock	60	70	-	degree	*2
	$\theta_R$	3 o'clock	60	70	-		
	$\theta_T$	12 o'clock	40	50	-		
	$\theta_B$	6 o'clock	60	70	-		
Response Time	$T_f$	Normal $\theta=0^\circ$	-	10	20	msec	*3
	$T_r$		-	15	30	msec	
Contrast ratio	CR		400	500	-	-	*1
Color chromaticlty	$W_X$		0.26	0.31	0.26	-	
	$W_Y$		0.28	0.33	0.38	-	
Luminance	L		-	250	-	cd/m <sup>2</sup>	*4
Luminance uniformity	$Y_U$		70	75	-	%	*4

Note:

**\*1. Definition of Contrast Ratio**

The contrast ratio could be calculate by the following expression:

Contrast Ratio (CR) = Luminanc with all pixels white / Luminance with all pixels black

**\*2 Definition of Viewing Angle**

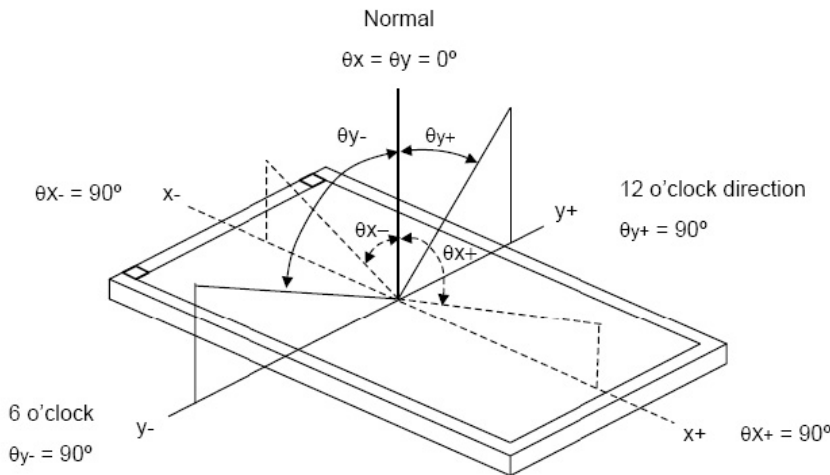

**\*3 Definition of response time**

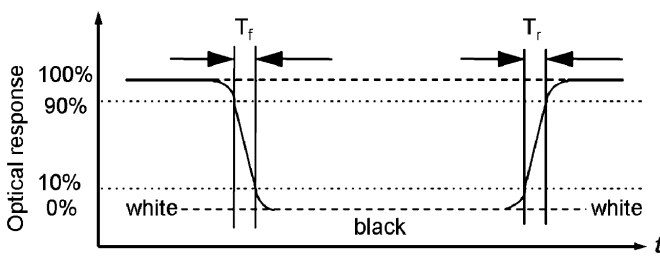

**\*4 Definition of Luminance Uniformity**

Luminance uniformity (Lu)=

Min. Luminance form pt1~pt9 / Max Luminance form Pt1~pt9

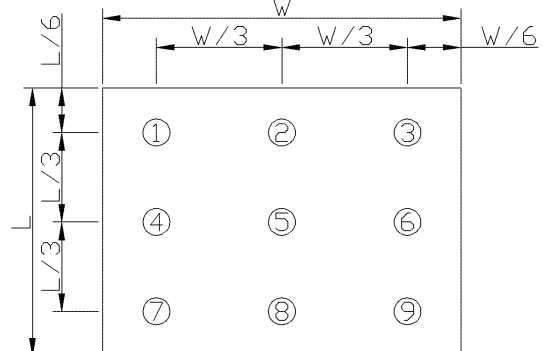

\*5. Measured with TFT and backlight only

## 9. Function Specifications

### 9.1 Touch Panel Controller Functions

#### 9.1.1 Command Registers Functions

Bit	Mnemonic	Descriptions	Note
D7	S	Start Bit	S=1 to start
D6~D4	A2~A0	A[2:0]=001, for X direction A/D A[2:0]=101, for Y direction A/D	
D3	MODE	MODE=0, for 12bit resolution mode MODE=1, for 8bit resolution mode	MODE=0, for 12bit precision
D2	SER/DFR	SER/DFR=0, Differential Reference Mode SER/DFR=1, Not used	SER/DFR=0, for touch panel use
D1~D0	PD1,PD0	PD1=0, power save mode PD1=1, normal running PD0=0, enable /PENIRQ PD0=1, disable /PENIRQ	PD[1:0]=10, for full function enable

Note. Please Refer to AD7843 datasheet for details.

#### 9.1.2 Command and Signal Flow Diagram

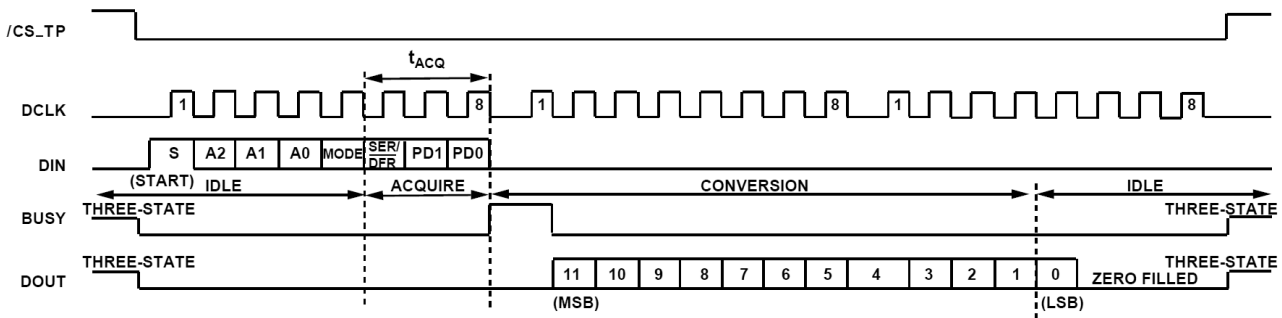

Note.  
Suggested DCLK speed is 2MHz



**9.2 TFT Controller Functions**

**9.2.1 Display Memory Addressing**

TFT module with 800x480 pixels, using T8010, address the display memory with a co-ordinate system as follow.

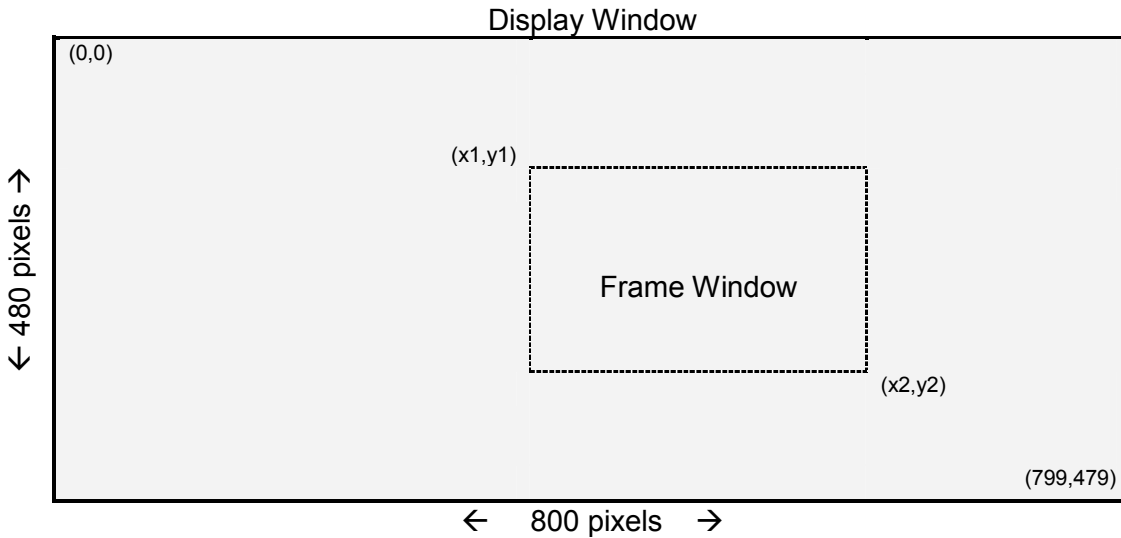

**9.2.2 Memory Address Control Registers**

Address Pointer (x0,y0)

- it is a pointer that point to the next data location will be access
- It define by (x0, y0)
- x0, y0 should inside the Display Window
- It should be  $0 \leq x0 \leq 799$
- It should be  $0 \leq y0 \leq 479$

Frame Window (x1,y1)~(x2,y2)

- It is for some special command like draw\_box, fill\_window
- It should be locate inside the Display window
- Frame Window setup by (x1,y1) & (x2,y2)
- (x1,y1) is the top-left co-ordinate
- (x2,y2) is the bottom-right co-ordinate
- it should be  $x1 \leq x2$
- it should be  $y1 \leq y2$

Display Window (0,0)~(799,479)

- It is all of the display area,
- It contain 800x480 dot
- (0,0) is the top-left co-ordinate
- (799,479) is the bottom-right co-ordinate

Draw 8dot Command Memory Addressing

- dwg\_solid8 and dwg\_tran8 could “draw” 8 dots at a time
- The memory mapping is as follow, (MSB is on the left-side, LSB is on the right-side)

	<b>x0</b>	<b>x0+1</b>	<b>x0+2</b>	...
<b>y0</b>	D7 ..D0	D7 ..D0	D7 ..D0	...

**9.2.3 Display Command Set**

No.	Command	hex	/RD	/WR	RS	D15	D14	D13	D12	D11	D10	D9	D8	D7	D6	D5	D4	D3	D2	D1	D0	Descriptions
1	set_x0	0040	1 1	0 0	0 1	0 x	0 x	0 x	0 x	0 x	0 x	0 n	0 n	0 n	1 n	0 n	0 n	0 n	0 n	0 n	0 n	Set pointer x0 x0 value
2	set_y0	0041	1 1	0 0	1 1	0 x	0 x	0 x	0 x	0 x	0 x	0 n	0 n	0 n	0 n	0 n	0 n	0 n	0 n	0 n	0 n	Set pointer y0 y0 value
3	set_x1	0042	1 1	0 0	1 1	0 x	0 x	0 x	0 x	0 x	0 x	0 n	0 n	0 n	0 n	0 n	0 n	0 n	0 n	0 n	0 n	Set register x1 x1 value
4	set_y1	0043	1 1	0 0	1 1	0 x	0 x	0 x	0 x	0 x	0 x	0 n	0 n	0 n	0 n	0 n	0 n	0 n	0 n	0 n	0 n	Set register y1 y1 value
5	set_x2	0044	1 1	0 0	1 1	0 x	0 x	0 x	0 x	0 x	0 x	0 n	0 n	0 n	0 n	0 n	0 n	0 n	0 n	0 n	0 n	Set register x2 x2 value
6	set_y2	0045	1 1	0 0	1 1	0 x	0 x	0 x	0 x	0 x	0 x	0 n	0 n	0 n	0 n	0 n	0 n	0 n	0 n	0 n	0 n	Set register y2 y2 value
7	set_fg_color	0046	1 1	0 0	1 1	0 R	0 R	0 R	0 R	0 R	0 G	0 G	0 G	0 G	0 G	0 G	0 B	0 B	0 B	0 B	0 B	Set fg_color register Color value RGB=[5:6:5]
8	set_bg_color	0047	1 1	0 0	1 1	0 R	0 R	0 R	0 R	0 G	0 G	0 G	0 G	0 G	0 G	0 B	0 B	0 B	0 B	0 B	0 B	Set bg_color register Color value RGB=[5:6:5]
9	set_func	0048	1 1	0 0	0 0	0 x	0 x	0 x	0 x	0 x	0 x	0 x	0 x	0 x	0 x	0 1	0 1	0 p	0 p	0 p	0 p	Set Func register Backlight PWM driving pppp=0000: fully off; ... ; pppp=1111: fully on
10	fill_pixel	0081	1 1	0 0	1 1	0 R	0 R	0 R	0 R	0 R	0 G	0 G	0 G	0 G	0 G	0 B	0 B	0 B	0 B	0 B	0 B	Fill a Pixel with given color at (x0, y0) Pixel Color Value RGB=[5:6:5] (support continue draw)
11	dwg_pixel	0082	1 1	0 0	0 0	0 0	0 0	0 0	0 0	0 0	0 0	0 0	0 0	0 0	0 0	0 0	0 0	0 0	0 0	0 0	0 0	Draw a pixel with fg_color at (x0, y0)
12	dwg_solid8	0083	1 1	0 0	1 1	0 0	0 0	0 0	0 0	0 0	0 0	0 0	0 0	0 0	0 0	0 0	0 0	0 0	0 0	0 0	0 0	Draw 8 horizontal pixels at (x0, y0) (support continue draw) d=1: fill fg_Color d=0: fill bg_color
13	dwg_tran8	0084	1 1	0 0	1 1	0 0	0 0	0 0	0 0	0 0	0 0	0 0	0 0	0 0	0 0	0 0	0 0	0 0	0 0	0 0	0 0	Draw 8 horizontal pixels at (x0, y0) (support continue draw) d=1: fill fg_color d=0: keep on Screen Color (no change, transparence)
14	dwg_box	0085	1 1	0 0	0 0	0 0	0 0	0 0	0 0	0 0	0 0	0 0	0 0	0 0	0 0	0 0	0 0	0 0	0 0	0 0	0 0	Draw Box (x1, y1) to (x2, y2) fill with fg_color (where x1≤x2, y1≤y2)
15	clr_scr	0086	1 1	0 0	0 0	0 0	0 0	0 0	0 0	0 0	0 0	0 0	0 0	0 0	0 0	0 0	0 0	0 0	0 0	0 0	0 0	Fill the whole screen with bg_color
16	fill_window	0087	1 1	0 0	1 1	0 R	0 R	0 R	0 R	0 R	0 G	0 G	0 G	0 G	0 G	0 G	0 B	0 B	0 B	0 B	0 B	Fill the area (x1, y1) to (x2, y2) Pixel Color Value RGB=[5:6:5] (accept multi-Pixels data continue filling inside the window, till next command)
17	get_status	--	0 0	1 1	0 0	v v	v v	v v	v v	v v	v v	v v	v v	b s	×	×	×	×	×	×	×	Get Status D[15:12]: firmware version, D[11:8]: sub version D[7]: busy flag b=1, Busy; b=0, Ready D[6]: display on/off flag s=1, ON; s=0: OFF D[5:0]: Reserved

Note. Please Refer to T8010 technical manual for details.

## 10. Precautions of using LCD Modules

### Mounting

- Mounting must use holes arranged in four corners or four sides.
- The mounting structure so provide even force on to LCD module. Uneven force (ex. Twisted stress) should not applied to the module. And the case on which a module is mounted should have sufficient strength so that external force is not transmitted directly to the module.
- It is suggested to attach a transparent protective plate to the surface in order to protect the polarizer. It should have sufficient strength in order to the resist external force.
- The housing should adopt radiation structure to satisfy the temperature specification.
- Acetic acid type and chlorine type materials for the cover case are not desirable because the former generates corrosive gas of attacking the polarizer at high temperature and the latter causes circuit break by electro-chemical reaction.
- Do not touch, push or rub the exposed polarizers with glass, tweezers or anything harder than HB pencil lead. Never rub with dust clothes with chemical treatment. Do not touch the surface of polarizer for bare hand or greasy cloth.(Some cosmetics deteriorate the polarizer.)
- When the surface becomes dusty, please wipe gently with absorbent cotton or other soft materials like chamois soaks with petroleum benzine. Normal-hexane is recommended for cleaning the adhesives used to attach front / rear polarizers. Do not use acetone, toluene and alcohol because they cause chemical damage to the polarizer.
- Wipe off saliva or water drops as soon as possible. Their long time contact with polarizer

### Operating

- The spike noise causes the mis-operation of circuits. It should be within the  $\pm 200\text{mV}$  level (Over and under shoot voltage)
- Response time depends on the temperature.(In lower temperature, it becomes longer.)
- Brightness depends on the temperature. (In lower temperature, it becomes lower.) And in lower temperature, response time(required time that brightness is stable after turned on) becomes longer.
- Be careful for condensation at sudden temperature change. Condensation makes damage to polarizer or electrical contacted parts. And after fading condensation, smear or spot will occur.
- When fixed patterns are displayed for a long time, remnant image is likely to occur.
- Module has high frequency circuits. Sufficient suppression to the electromagnetic interference shall be done by system manufacturers. Grounding and shielding methods may be important to minimized the interference

### Electrostatic Discharge Control

Since a module is composed of electronic circuits, it is not strong to electrostatic discharge. Make certain that treatment persons are connected to ground through wrist band etc. And don't touch interface pin directly.

### Strong Light Exposure

Strong light exposure causes degradation of polarizer and color filter.

### Storage

When storing modules as spares for a long time, the following precautions are necessary.

- Store them in a dark place. Do not expose the module to sunlight or fluorescent light. Keep the temperature between  $5^{\circ}\text{C}$  and  $35^{\circ}\text{C}$  at normal humidity.
- The polarizer surface should not come in contact with any other object. It is recommended that they be stored in the container in which they were shipped.

### Protection Film

- When the protection film is peeled off, static electricity is generated between the film and polarizer. This should be peeled off slowly and carefully by people who are electrically grounded and with well ion-blown equipment or in such a condition, etc.
- The protection film is attached to the polarizer with a small amount of glue. If some stress is applied to rub the protection film against the polarizer during the time you peel off the film, the glue is apt to be main on the polarizer. Please carefully peel off the protection film without rubbing it against the polarizer.
- When the module with protection film attached is stored for a long time, sometimes there remains a very small amount of glue still on the polarizer after the protection film is peeled off.
- You can remove the glue easily. When the glue remains on the polarizer surface or its vestige is recognized, please wipe them off with absorbent cotton waste or other soft material like chamois soaked with normal-hexane.

### Transportation

The LCD modules should be no falling and violent shocking during transportation, and also should avoid excessive press, water, damp and sunshine.

## 11. Appendix <Inspection items and criteria for appearance defect>

### Bright/Dark Dots:

Defect Type	Specification	Major	Minor
Bright Dots	$N \leq 2$		•
Dark Dots	$N \leq 3$		•
Total Bright and Dark Dots	$N \leq 4$		•

Note: 1. **The definition of dot:** The size of a defective dot over 1/2 of whole dot is regarded as one defective dot.

2. **Bright dot:** Dots appear bright and unchanged in size in which LCD panel is displaying under black pattern.
3. **Dark dot:** Dots appear dark and unchanged in size in which LCD panel is displaying under pure red, green, blue pattern.

**附录: Touch panel Design Precautions**

1. It should prevent front case touching the touch panel Active Area (A.A.) to prevent abnormal touch.  
It should left gab (e.g. 0.2~0.3mm) in between.

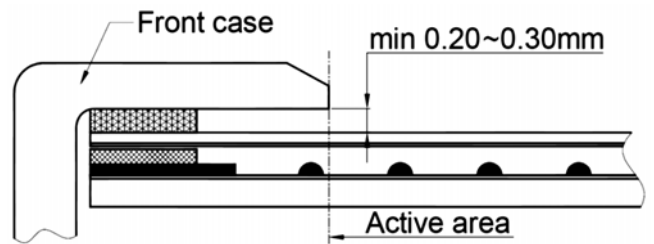

2. Outer case design should take care about the area outside the A.A.  
Those areas contain circuit wires which is having different thickness. Touching those areas could deform the ITO film. As a result case the ITO cold be damaged and shorten its lifetime.  
It is suggested to protect those areas with gasket (between the front case and the touch panel).  
The suggested figures are  $B \geq 0.50\text{mm}$ ;  $C \geq 0.50\text{mm}$ .

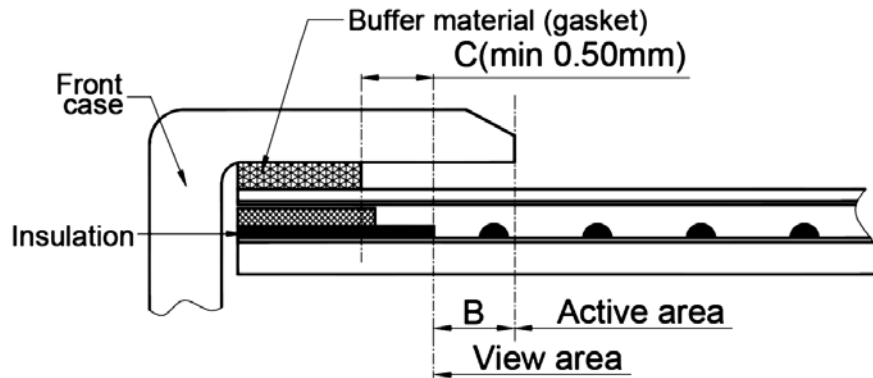

3. The front case side wall should keep space (e.g. 0.2 ~ 0.3mm) from the touch panel.

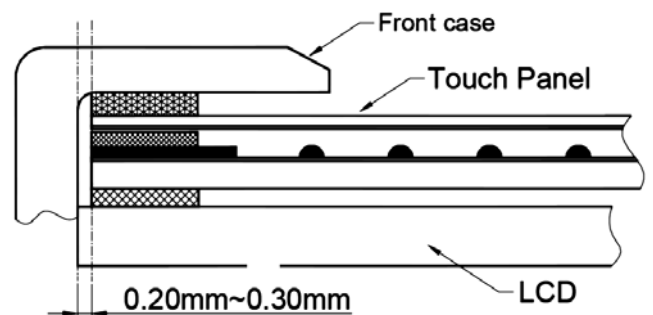

4. In general design,  
touch panel V.A. should be bigger than the LCD V.A.  
and touch panel A.A. should be bigger than the LCD A.A.

