



深圳市拓普微科技开发有限公司

SHENZHEN TOPWAY TECHNOLOGY CO., LTD.

LMT101DNLFW-D-NND

LCD Module User Manual

Prepared by: Liu Tihou Date: 2016-12-17	Checked by: Date:	Approved by: Date:
--	----------------------------------	-----------------------------------

Rev.	Descriptions	Release Date
0.1	Preliminary release	2016-12-17

Table of Content

1. General Specification	3
2. Input/Output Terminals	4
3. Absolute Maximum Ratings.....	5
4. Electrical Characteristics.....	6
5. Timing Chart.....	9
6. Optical Characteristics.....	12
7. Environmental / Reliability Test	15
8. Precautions for Use of LCD Modules	16

1. General Specification

1.1 Display Spec & Electrical Characteristics

Feature		Spec
Display Spec.	Size	10.1 inch
	Resolution	1280(RGB) x 800
	Technology Type	SFT
	Pixel Configuration	R.G.B. Vertical Stripe
	Pixel Pitch (mm)	0.178x0.178
	Display Mode	Normally Black
	Surface Treatment(Up Polarizer)	HC
	Viewing Direction	All direction
Mechanical Characteristics	LCM (W x H x D) (mm)	258.66x177.30x12.45
	Active Area(mm)	216.96x135.60
	With /Without TSP	With CTSP
	Matching Connection Type	CN1:JAE FI-SE20P-HFE-E3000 CN2:JAE FI-S6P-HFE-E1500 CN3:MOLEX 53261-0871
	Weight (g)	TBD
Electrical Characteristics	Interface	LVDS, 6/8bit selectable
	Color Depth	262K/16.7M

Note 1: Viewing direction for best image quality is different from TFT definition, there is a 180 degree shift.

Note 2 : Requirements on Environmental Protection: Q/S0002

Note 3 : LCM weight tolerance : +/- 5%

2. Input/Output Terminals

2.1TFT LCD Panel

CN1:JAE FI-SE20P-HFE-E3000

No	Symbol	I/O	Description	Comment
1	IND3+	I	Positive LVDS Differential data input(3)	
2	IND3-	I	Negative LVDS Differential data input(3)	
3	NC	-	No Connection	
4	SEL6/8	I	6bit/8bit mode select H : 6-bit mode L : 8-bit mode	
5	VSS	P	Power Ground	
6	PINC+	I	Positive LVDS Differential clock input	
7	NINC-	I	Negative LVDS Differential clock input	
8	VSS	P	Power Ground	
9	IND2+	I	Positive LVDS Differential data input(2)	
10	IND2-	I	Negative LVDS Differential data input(2)	
11	VSS	P	Power Ground	
12	IND1+	I	Positive LVDS Differential data input(1)	
13	IND1-	I	Negative LVDS Differential data input(1)	
14	VSS	P	Power Ground	
15	IND0+	I	Positive LVDS Differential data input(0)	
16	IND0-	I	Negative LVDS Differential data input(0)	
17	VSS	P	Power Ground	
18	NC	-	No Connection	
19	VDD	P	Power Supply	
20	VDD	P	Power Supply	

CN2:JAE FI-S6P-HFE-E1500

No	Symbol	I/O	Description	Comment
1	VLED	P	Backlight power supply	
2	VLED	P	Backlight power supply	
3	VLSS	P	VLED Ground	
4	VLSS	P	VLED Ground	
5	LED_EN	I	Backlight on/off control	
6	LED_PWM	I	Backlight dimming control	

CN3:MOLEX 53261-0871

No	Symbol	I/O	Description	Comment
1	VDD1	P	Power for ctp	
2	D-	I/O	USB data- pin	
3	D+	I/O	USB data+ pin	
4	VSS1	P	Power Ground	
5	NC	-	No Connection	
6	NC	-	No Connection	
7	NC	-	No Connection	
8	NC	-	No Connection	

Note: I/O definition: I-----Input O-----output P----Power/Ground

3. Absolute Maximum Ratings

3.1 Driving TFT LCD Panel

GND=0V

Item	Symbol	MIN	MAX	Unit	Remark
Voltage Input	V _{in}	-0.50	5.00	V	Note1
Operating Temperature	T _{op}	-20.0	70.0	°C	
Storage Temperature	T _{st}	-30.0	80.0	°C	
Relative Humidity (Note2)	RH	--	≤95	%	T _a ≤ 40°C
		--	≤85	%	40°C < T _a ≤ 50°C
		--	≤55	%	50°C < T _a ≤ 60°C
		--	≤36	%	60°C < T _a ≤ 70°C
		--	≤24	%	70°C < T _a ≤ 80°C
Absolute Humidity	AH	--	≤70	g/m ³	T _a > 70°C

Table 3.1 absolute maximum rating

Note1: Input voltage include Rxin0-/+, Rxin1-/+, Rxin2-/+, Rxin3-/+, RxCLK-/+, SEL6/8,VDD.

Note2: T_a means the ambient temperature.

It is necessary to limit the relative humidity to the specified temperature range.

Condensation on the module is not allowed.

4. Electrical Characteristics

4.1 Driving TFT LCD Panel

VCC=3.3V, GND=0V, Ta=25°C

Item	Symbol	MIN	TYP	MAX	Unit	Remark
Power supply Voltage	VDD	3.00	3.30	3.60	V	
Power supply ripple	Vp-p	-	-	100	mV	
Power supply current	IDD	-	280	-	mA	
Power consumption	P	-	924	-	mW	Note1
Differential input voltage	Vid	200	-	600	mV	
Differential input common voltage	Vcom	-	1.2	-	V	
Differential input threshold voltage	Low level	VTL	-100	-	-	mV
	High level	VTH	-	-	100	mV
Inrush current	Irush	-	-	1.5	A	

Table 4.1 LCD module electrical characteristics

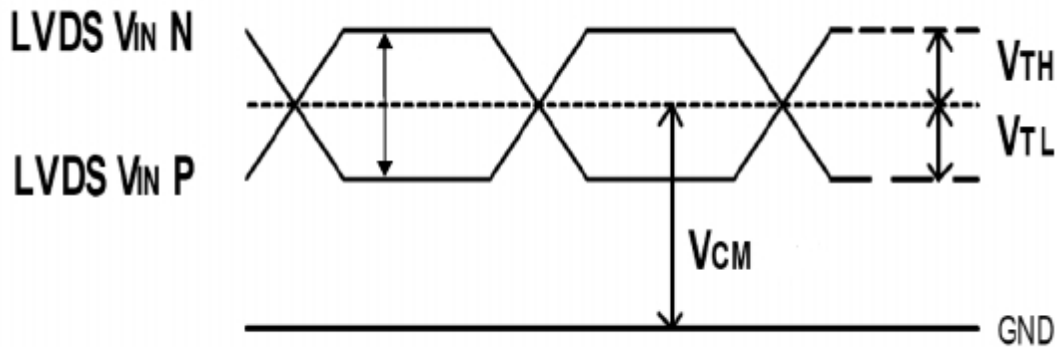

Figure4.1.1 LVDS DC characteristics

Note1: To test the current dissipation, using the “color bar” testing pattern shown as below:

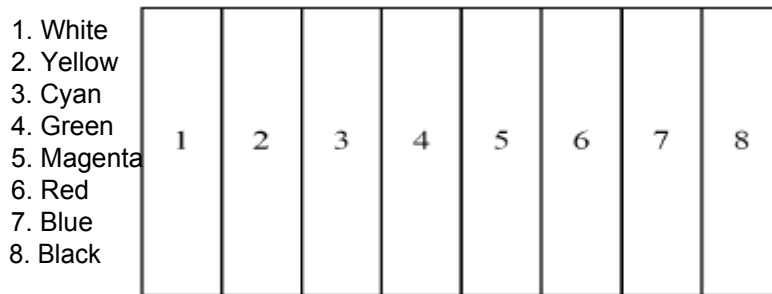

Figure 4.1.2 Current dissipation testing pattern

4.2 Driving Backlight

Ta=25°C

Item	Symbol	Min	Typ	Max	Unit	Remark	
Backlight power supply voltage	VLED	11.5	12	12.5	V		
Backlight power supply current	I_LED	-	TBD	-	mA		
Backlight power consumption	P_LED	-	TBD	-	mW		
Input voltage for VLED_PWM signal	High level	-	2.0	-	5.0	V	
	Low level	-	0	-	0.4	V	
Input voltage for VLED_EN	High level	-	2.0	-	5.0	V	
	Low level	-	0	-	0.4	V	
VLED_PWM frequency	Fpwm	200	-	20k	HZ		
VLED_PWM duty	D	5		100	%	Note1	
Operating Life Time	--	--	50000	--	hrs	Note2	

Note 1: According to LED driver IC characteristics, the minimum value of VLED_PWM duty may vary with VLED_PWM frequency, higher the frequency, bigger the duty.

Note 2: Optical performance should be evaluated at Ta=25°C only. If LED is driven by high current, high ambient temperature & humidity condition. The life time of LED will be reduced.

Operating life means brightness goes down to 50% of initial brightness. Typical operating life time is estimated data.

4.3 Block Diagram

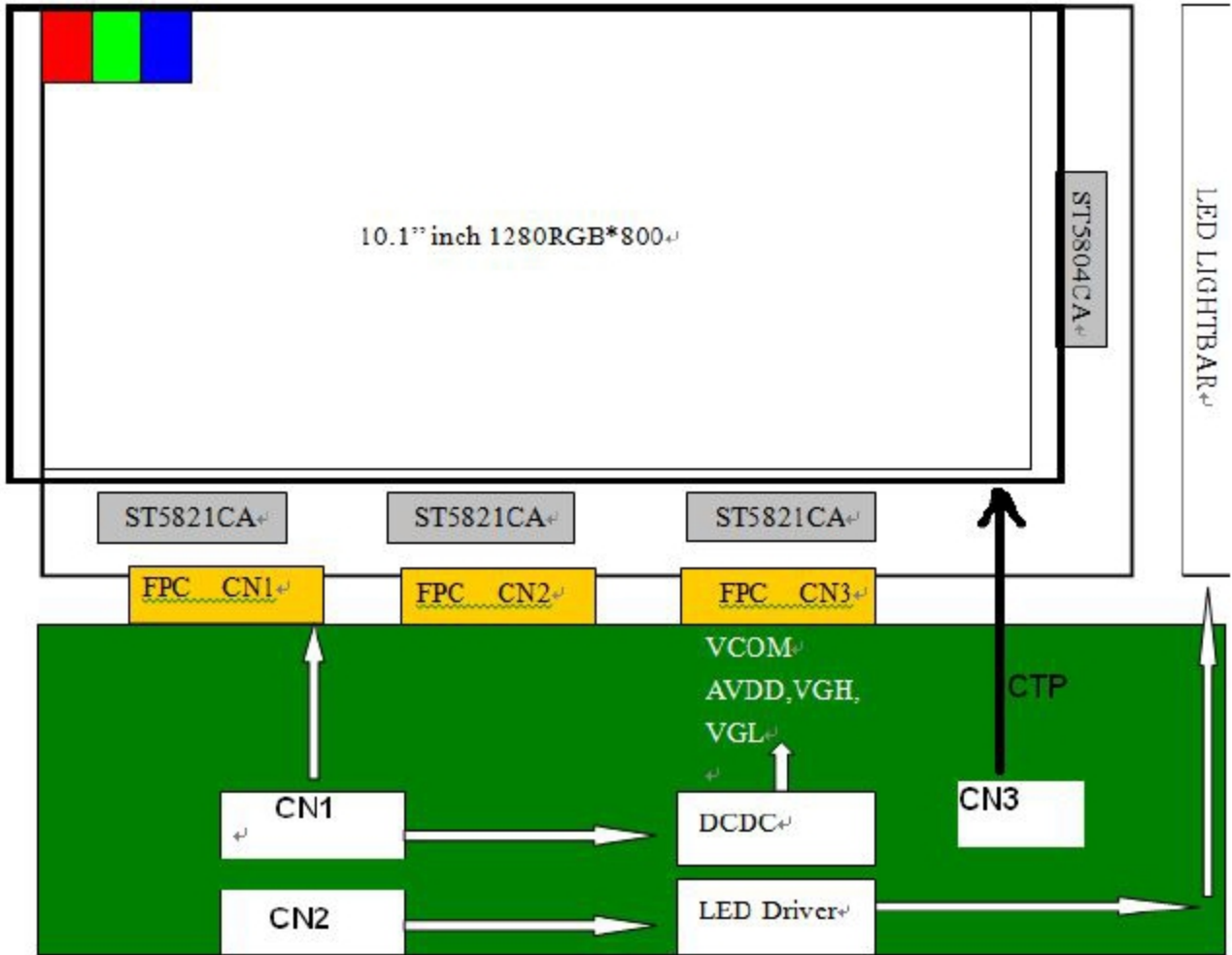

5. Timing Chart

5.1 LVDS signal timing characteristics

VCC=3.3V, GND=0V, Ta=25°C

Parameter	Symb ol	Min	Typ	Max	Unit	Remark
CLK frequency	1/t _{clk}	62.6	68.2	78.1	MHz	
Horizontal blanking time	t _{HBT}	20	69	164	t _{clk}	t _{hbp} + t _{HFP}
Horizontal back porch	t _{HBP}	-	5	164- t _{HFP}	t _{clk}	
Horizontal display area	t _{HD}	-	1280	-	t _{clk}	
Horizontal front porch	t _{HFP}	15	64	159	t _{clk}	
Horizontal period	t _H	1300	1349	1444	t _{clk}	
Horizontal pulse width	t _{HPW}	-	1	256	t _{clk}	
Vertical blanking time	t _{VBT}	5	42	101	t _H	t _{vbp} + t _{VFP}
Vertical back porch	t _{VBP}	-	2	101- t _{VFP}	t _H	
Vertical display area	t _{VD}	-	800	-	t _H	
Vertical front porch	t _{VFP}	3	40	99	t _H	
Vertical period	t _V	803	842	901	t _H	
Vertical pulse width	t _{VPW}	-	1	128	t _H	
Frame Rate	F	-	60	-	HZ	

Table 5.1 timing parameter

5.2 Input Clock and Data timing Diagram:

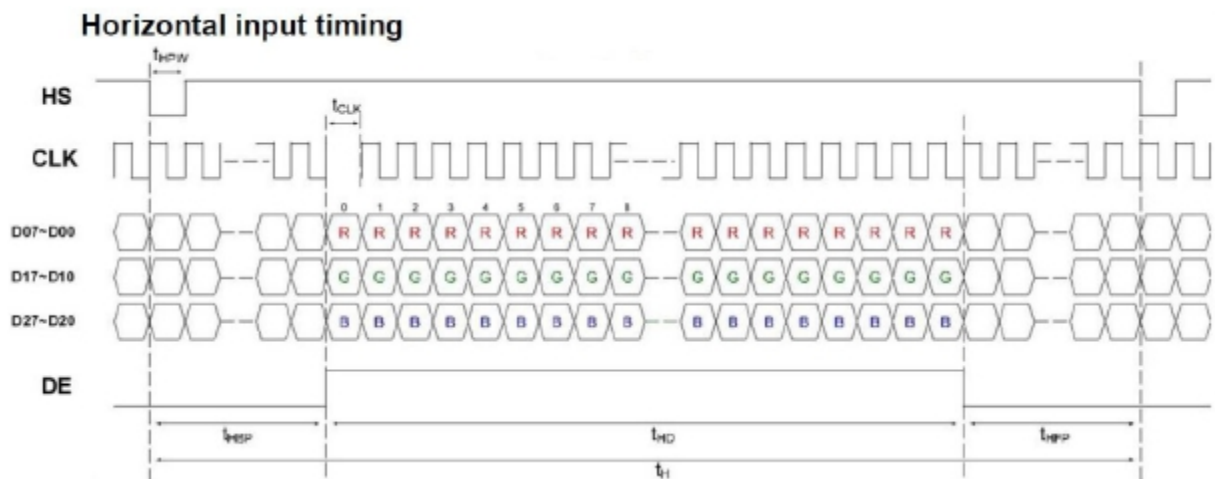

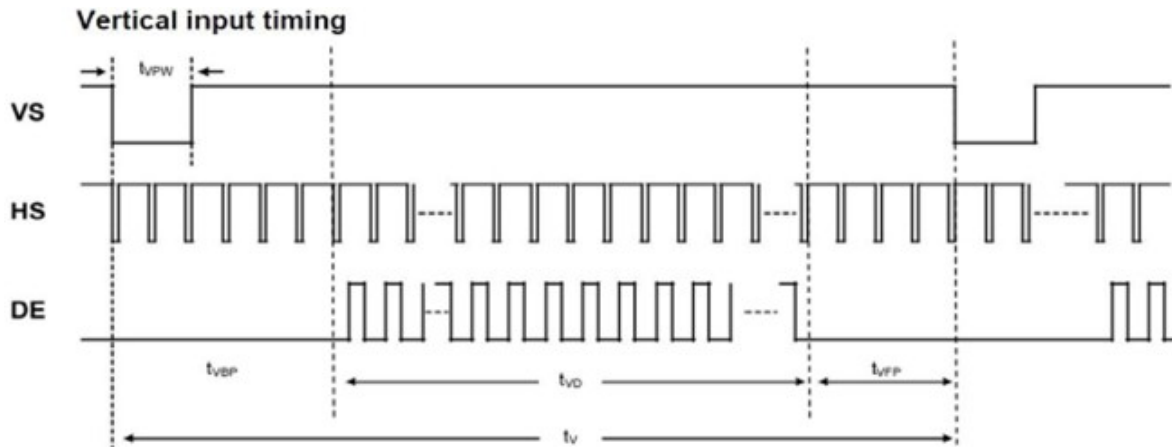
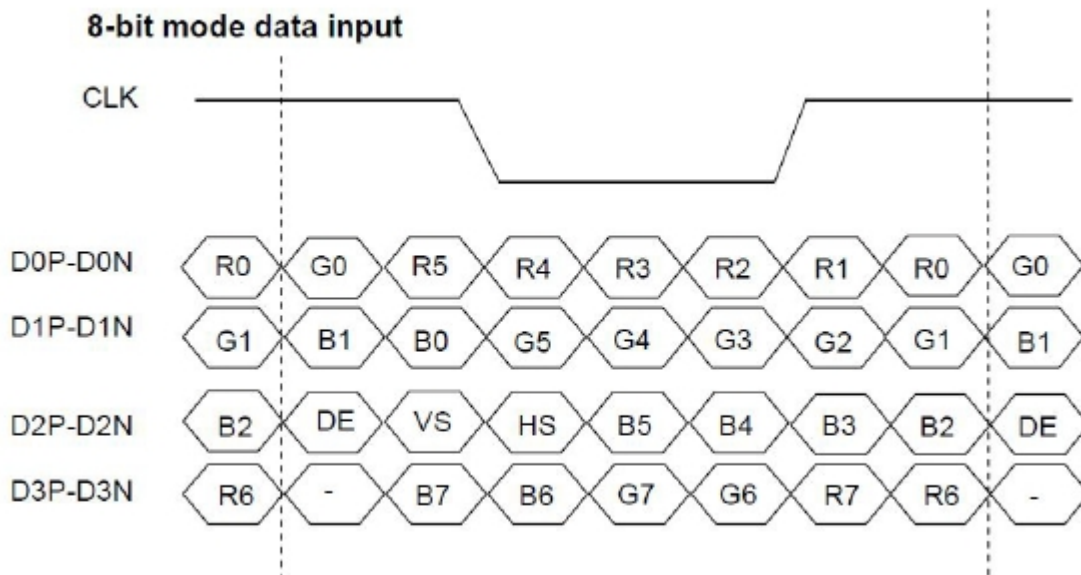

Figure 5.2 Input signal data timing

5.3 LVDS data input format

8-bit mode data input



6-bit mode data input

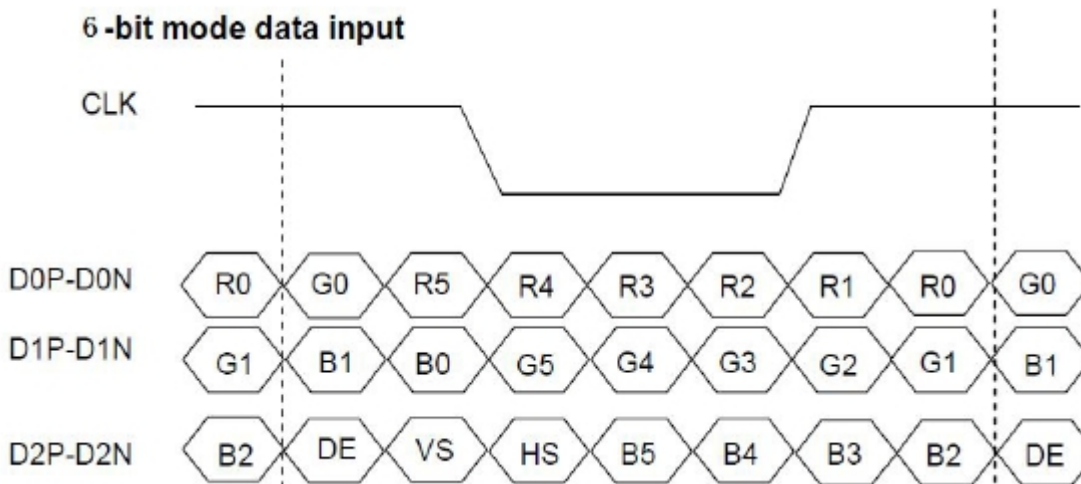

5.4 Power On/Off Sequence

Item	Symbol	Min	Typ	Max	Unit	Remark
VDD on to VDD stable	Tp1	0.5	-	10	ms	
VDD stable to signal on	Tp2	0	-	50	ms	
Signal on to VLED_EN on	Tp3	200	-	-	ms	
PWM on to VLED_EN on	Tp4	0	-	200	ms	
VLED to PWM on	Tp5	10	-	-	ms	
VLED on to VLED stable	Tp6	0.5	-	10	ms	
VDD off time	Tp7	0	-	10	ms	
VDD off to next VDD on	Tp8	500	-	-	ms	
Signal off before VDD off	Tp9	0	-	50	ms	
VLED_EN off before signal off	Tp10	200	-	-	ms	
VLED_EN off before PWM off	Tp11	0	-	200	ms	
PWM off before VLED off	Tp12	10	-	-	ms	

Table 5.1 Power on/off sequence

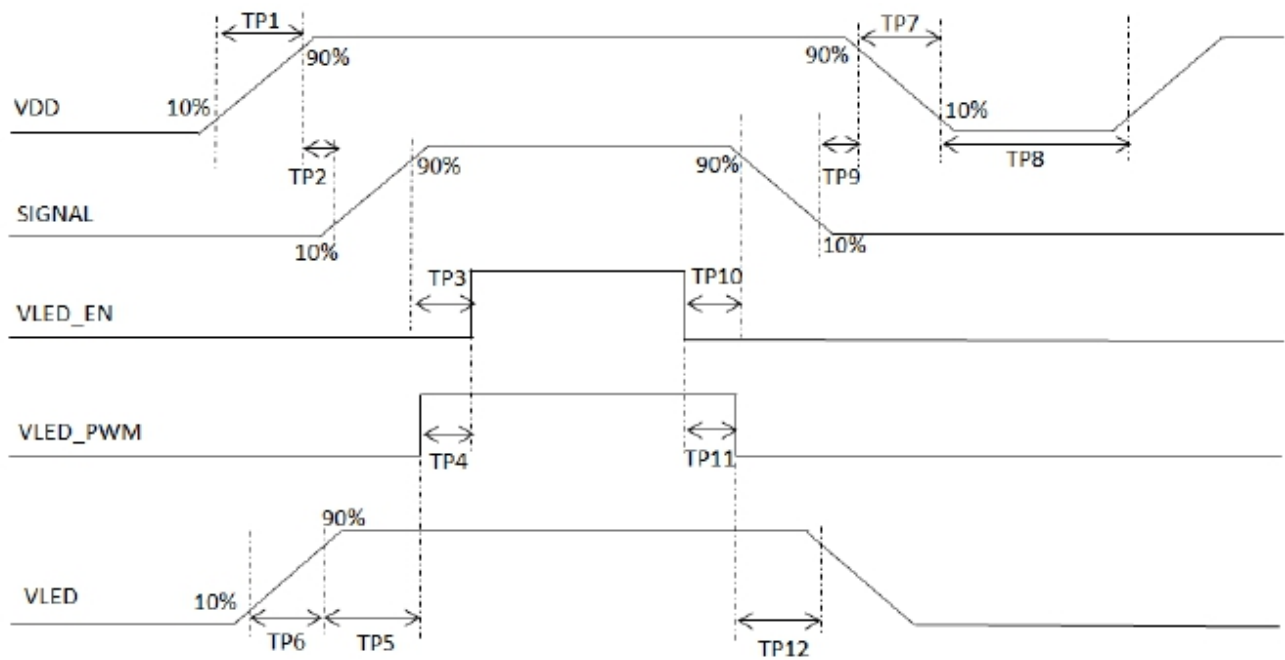

Figure 5.2 Interface power on/off sequence

6. Optical Characteristics

6.1 Optical Specification

Ta=25°C

Item	Symbol	Condition	Min	Typ	Max	Unit	Remark
View Angles	θT	CR ≧ 10	75	85	-	Degree	Note 2
	θB		75	85	-		
	θL		75	85	-		
	θR		75	85	-		
Contrast Ratio	CR	θ=0°	600	800	-	-	Note1 Note3
Response Time	T _{ON} +T _{OFF}	25°C	-	25	40	ms	Note1 Note4
Chromaticity	White	x	0.252	0.302	0.352	-	Note5 Note1
		y	0.277	0.327	0.377		
	Red	x	0.532	0.582	0.632		
		y	0.274	0.324	0.374		
	Green	x	0.300	0.350	0.400		
		y	0.532	0.582	0.632		
	Blue	x	0.104	0.154	0.204		
		y	0.044	0.094	0.144		
Uniformity	U	-	75	80	-	%	Note1 Note6
NTSC	-	-	45	50	-	%	Note 5
Luminance	L		700	850	-	cd/m ²	Note1 Note7

Test Conditions:

1. The ambient temperature is 25±2°C.humidity is 65±7%
2. The test systems refer to Note 1 and Note 2.

Note 1: Definition of optical measurement system.

The optical characteristics should be measured in dark room. After 5 Minutes operation, the optical properties are measured at the center point of the LCD screen. All input terminals LCD panel must be ground when measuring the center area of the panel.

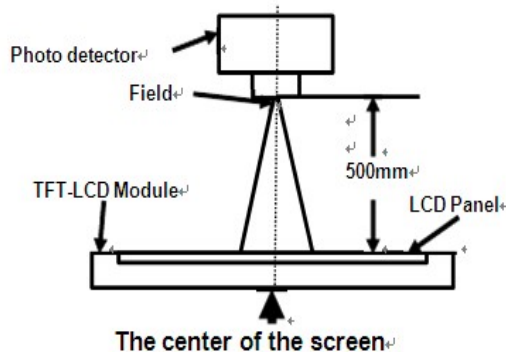

Note 2: Definition of viewing angle range and measurement system.

viewing angle is measured at the center point of the LCD.

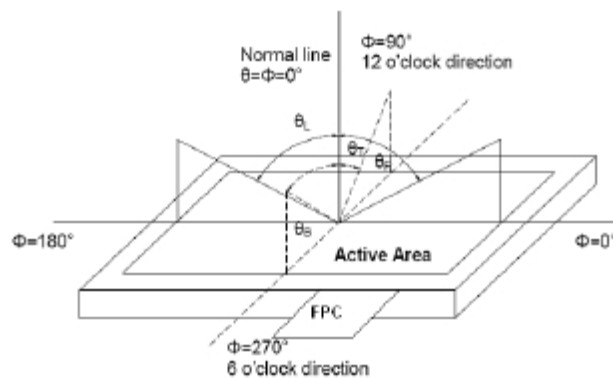

Note 3: Definition of contrast ratio

$$\text{Contrast ratio (CR)} = \frac{\text{Luminance measured when LCD is on the "White" state}}{\text{Luminance measured when LCD is on the "Black" state}}$$

“White state”: The state is that the LCD should driven by V_{white} .

“Black state”: The state is that the LCD should driven by V_{black} .

V_{white} : To be determined

V_{black} : To be determined.

Note 4: Definition of Response time

The response time is defined as the LCD optical switching time interval between “White” state and “Black” state. Rise time (TON) is the time between photo detector output intensity changed from 90% to 10%. And fall time (TOFF) is the time between photo detector output intensity changed from 10% to 90%.

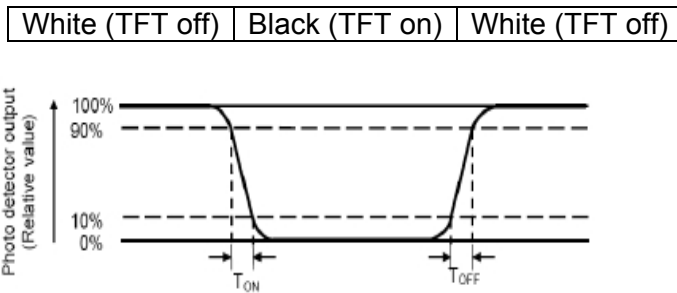

Note 5: Definition of color chromaticity (CIE1931)

Color coordinates measured at center point of LCD.

Note 6: Definition of Luminance Uniformity

Active area is divided into 9 measuring areas (Refer Fig. 2). Every measuring point is placed at the center of each measuring area.

L-----Active area length W----- Active area width

Luminance Uniformity (U) = L_{min} / L_{max}

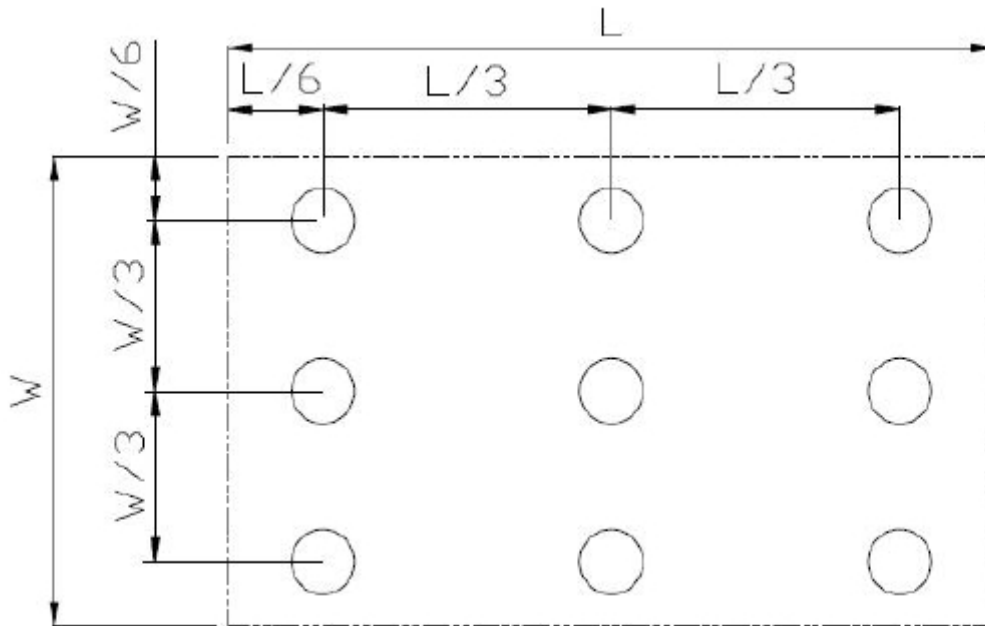

Lmax: The measured Maximum luminance of all measurement position.

Lmin: The measured Minimum luminance of all measurement position.

Note 7: Definition of Luminance:

Measure the luminance of white state at center point.

7. Environmental / Reliability Test

No	Test Item	Condition	Remark
1	High Temperature Operation	Ts=+70℃, 240hrs	(Note1) IEC60068-2-1:2007,GB2423.2-2008
2	Low Temperature Operation	Ta=-20℃, 240hrs	IEC60068-2-1:2007 GB2423.1-2008
3	High Temperature Storage (non-operation)	Ta=+80℃, 240hrs	IEC60068-2-1:2007 GB2423.2-2008
4	Low Temperature Storage (non-operation)	Ta=-30℃, 240hrs	IEC60068-2-1:2007 GB2423.1-2008
5	High Temperature & High Humidity Operation	Ta = +60℃, 90% RH max,240 hours	(Note2) IEC60068-2-78 :2001 GB/T2423.3—2006
6	Thermal Shock (non-operation)	-30℃ 30 min~+80℃ 30 min, Change time:5min,100cycles	Start with cold temperature, End with high temperature, IEC60068-2-14:1984,GB2423.22-2002
7	Electro Static Discharge (operation)	C=150pF,R=330Ω; Contact:±4Kv, 5times; Air: ± 8KV,5times;	IEC61000-4-2:2001 GB/T17626.2-2006
8	Vibration (non-operation)	Frequency range:10~ 55Hz, Stroke:1.5mm Sweep:10Hz ~ 55Hz ~ 10Hz 2hours for each direction of X.Y.Z (6 hours total)	IEC60068-2-6:1982 GB/T2423.10—1995
9	Shock (non-operation)	60G 6ms, ±X,±Y,±Z 3 times for each direction	IEC60068-2-27:1987 GB/T2423.5—1995
10	Package Drop Test	Height:80 cm,1 corner, 3 edges, 6 surfaces	IEC60068-2-32:1990 GB/T2423.8—1995

Note1: Ts is the temperature of panel's surface.

Note2: Ta is the ambient temperature of sample.

8. Precautions for Use of LCD Modules

8.1 Handling Precautions

- a. The display panel is made of glass. Do not subject it to a mechanical shock by dropping it from a high place, etc.
- b. If the display panel is damaged and the liquid crystal substance inside it leaks out, be sure not to get any in your mouth, if the substance comes into contact with your skin or clothes, promptly wash it off using soap and water.
- c. Do not apply excessive force to the display surface or the adjoining areas since this may cause the color tone to vary.
- d. The polarizer covering the display surface of the LCD module is soft and easily scratched. Handle this polarizer carefully.
- e. If the display surface is contaminated, breathe on the surface and gently wipe it with a soft dry cloth. If still not completely clear, moisten cloth with one of the following solvents:
 - Isopropyl alcohol
 - Ethyl alcoholSolvents other than those mentioned above may damage the polarizer. Especially, do not use the following:
 - Water
 - Ketone
 - Aromatic solvents
- f. Do not attempt to disassemble the LCD Module.
- g. If the logic circuit power is off, do not apply the input signals.
- h. To prevent destruction of the elements by static electricity, be careful to maintain an optimum work environment.
 1. Be sure to ground the body when handling the LCD Modules.
 2. Tools required for assembly, such as soldering irons, must be properly ground.
 3. To reduce the amount of static electricity generated, do not conduct assembly and other work under dry conditions.
 4. The LCD Module is coated with a film to protect the display surface. Be care when peeling off this protective film since static electricity may be generated.

8.2 Storage precautions

- a. When storing the LCD modules, avoid exposure to direct sunlight or to the light of fluorescent lamps.
- b. The LCD modules should be stored under the storage temperature range. If the LCD modules will be stored for a long time, the recommend condition is:
Temperature : 0°C ~ 40°C Relatively humidity: ≤80%
- c. The LCD modules should be stored in the room without acid, alkali and harmful gas.

8.3 Transportation Precautions

- a. The LCD modules should be no falling and violent shocking during transportation, and also should avoid excessive press, water, damp and sunshine.