



深圳市拓普微科技开发有限公司

SHENZHEN TOPWAY TECHNOLOGY CO., LTD.

LMT101DNMFDD-ABA

LCD Module User Manual

Prepared by: Lu jianhui Date: 2018-03-12	Checked by: Date:	Approved by: Date:
---	----------------------------------	-----------------------------------

Rev.	Descriptions	Release Date
0.1	Preliminary release	2018-03-12

Table of Content

1. General Specification	3
2. Block Diagram.....	3
3. Terminal Function.....	4
3.1 K1 Power Terminal.....	4
3.2 K2 VGA Terminal	4
3.3 K3 Touch Panel Terminal Functions	4
4. Absolute Maximum Ratings	5
5. Electrical Characteristics	5
5.1 Driving TFT LCD Panel	5
5.2 Touch Panel Characteristics	5
6. Optical Characteristics	6
7. Touch panel Design Precautions.....	7
8. Precautions of using LCD Modules	8

1. General Specification

Signal Interface :	VGA
Display Mode :	Transmissive / Normal White
Screen Size(Diagonal) :	10.1"
Outline Dimension :	251.0 x 140.0x 13.6 (mm) (see attached drawing for details)
Active Area :	222.72 x 125.28 (mm)
Number of dots :	1024 x 600
Pixel Pitch :	0.2175 x 0.2088 (mm)
Pixel Configuration :	RGB Stripe
Backlight :	LED
Surface Treatment :	AG (3H)
Viewing Direction :	6 o'clock(*1)(gray-scale inverse) 12 o'clock(*2)
Operating Temperature :	0 ~ +50°C
Storage Temperature :	-10 ~ +60°C

Note:

*1. For saturated color display content (eg. pure-red, pure-green, pure-blue, or pure-colors-combinations).

*2. For "color scales" display content.

*3. Color tone may slightly change by Temperature and Driving Condition.

2. Block Diagram

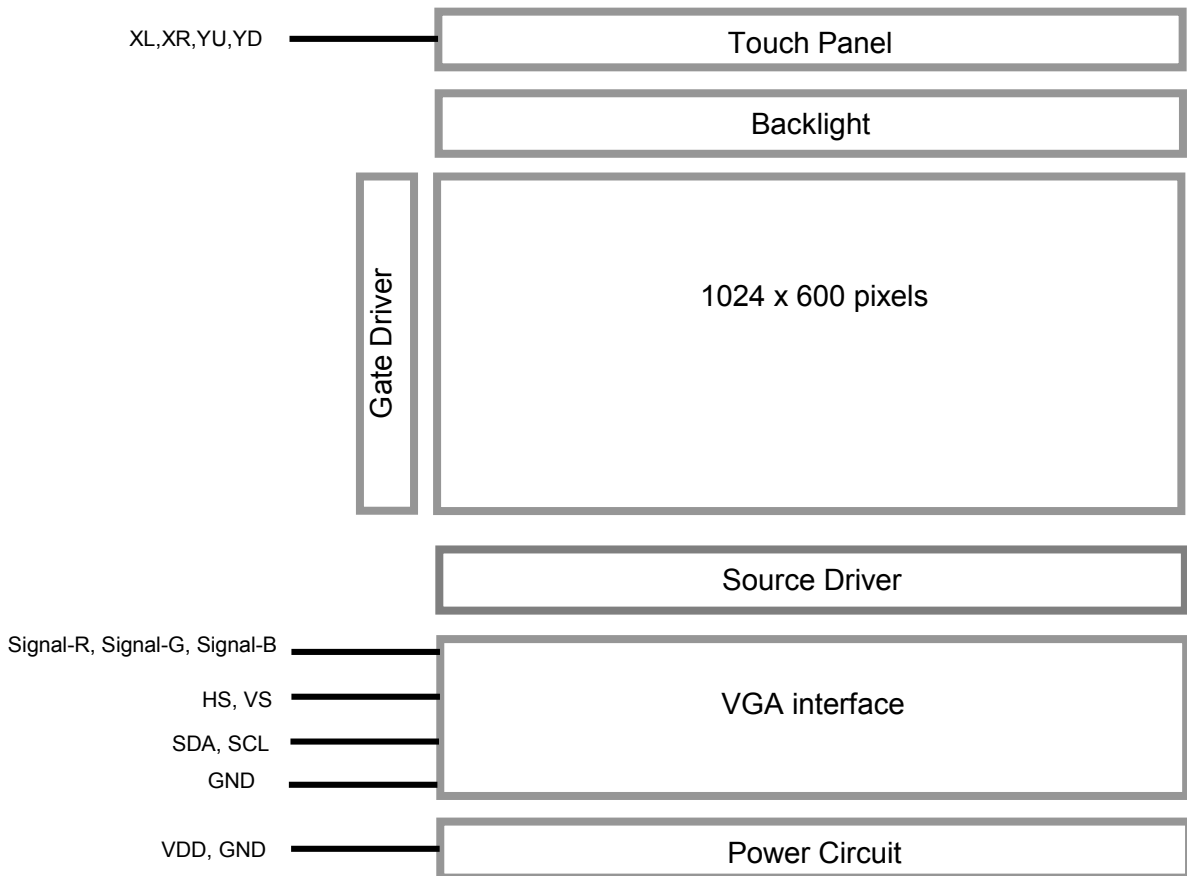

3. Terminal Function

3.1 K1 Power Terminal

Pin No.	Pin Name	I/O	Descriptions
1	VDD	Power	Positive Power Supply
2	VDD	Power	Positive Power Supply
3	NC	-	No connection
4	NC	-	No connection
5	VSS	Power	Power Ground
6	VSS	Power	Power Ground

3.2 K2 VGA Terminal

Pin No.	Pin Name	I/O	Descriptions
1	GND	Power	Signal Ground
2	VS	I	Analogue VGA Vertical Sync signal input
3	HS	I	Analogue VGA Horizontal Sync signal input
4	GND	Power	Signal Ground
5	Signal-R	I	Analogue VGA Red signal input
6	GND	Power	Signal Ground
7	Signal-G	I	Analogue VGA Green signal input
8	GND	Power	Signal Ground
9	Signal-B	I	Analogue VGA Blue signal input
10	GND	Power	Signal Ground
11	SDA	I/O	Serial data
12	SCL	I	Serial clock

3.3 K3 Touch Panel Terminal Functions

Pin No.	Pin Name	I/O	Descriptions
1	XL	Passive	Left Side sense Terminal
2	YD	Passive	Down Side sense Terminal
3	XR	Passive	Right Side sense Terminal
4	YU	Passive	Up Side sense Terminal

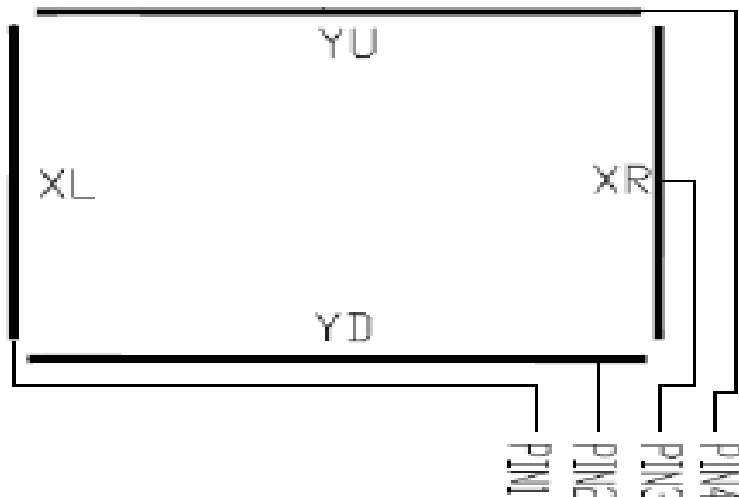

4. Absolute Maximum Ratings

Top=25°C, VDD =12V ,GND=0V

Items	Symbol	Min.	Max.	Unit	Condition
Power Supply voltage	VDD	-0.3	12.5	V	
Operating Temperature	T _{OP}	0	50	°C	No Condensation
Storage Temperature	T _{ST}	-10	60	°C	No Condensation
Operating and Storage Humidity	HSTG	10%	90%	%(RH)	

Note:

- *1. This rating applies to all parts of the module. And should not be exceeded.
- *2. The operating temperature only guarantees operation of the circuit. The contrast, response speed, and the other specification related to electro-optical display quality is determined at the room temperature, T_{OP}=25°C
- *3. Ambient temperature when the backlight is lit (reference value)
- *4. Any Stresses exceeding the Absolute Maximum Ratings may cause substantial damage to the device. Functional operation of this device at other conditions beyond those listed in the specification is not implied and prolonged exposure to extreme conditions may affect device reliability.

5. Electrical Characteristics

5.1 Driving TFT LCD Panel

Top=25°C, VDD =12V ,GND=0V

Items	Symbol	MIN.	TYP.	MAX.	Unit	Note
Supply Voltage	VDD	11.5	12.0	12.5	V	
VDD Power Consumption	I _{VDD}	300	345	600	mA	*1

Note.

- *1. Normal display condition

5.2 Touch Panel Characteristics

Top=25°C

Item	MIN.	TYP.	MAX.	UNIT	Applicable Pin
Terminal resistance	100	-	450	Ω	X- terminal
	400	-	1100	Ω	Y- terminal
Operating Voltage	-	-	5	V(DC)	-
Response time	-	-	10	ms	-
Operating force	20	-	120	g	-
Life Times	-	1000000	-	times	-

6. Optical Characteristics

Item	Symbol	Condition	MIN.	TYP.	MAX.	UNIT	Note.
Viewing angle (CR ≥ 10)	θ_L	9 o'clock	70	80	-	degree	*2
	θ_R	3 o'clock	70	80	-		
	θ_T	12 o'clock	65	75	-		
	θ_B	6 o'clock	70	80	-		
Response Time	T_f	Normal $\theta=0^\circ$	-	7	10	msec	*3
	T_r		-	9	18	msec	
Contrast ratio	CR		600	800	-	-	*1
Color chromaticlty	W_X		0.241	0.281	0.321	-	
	W_Y		0.260	0.300	0.340	-	
Luminance	L		200	240	-	cd/m ²	*4
Luminance uniformity	Y_U		70	80	-	%	*4

Note:

*1. Definition of Contrast Ratio

The contrast ratio could be calculate by the following expression:

Contrast Ratio (CR) = Luminanc with all pixels white / Luminance with all pixels black

*2 Definition of Viewing Angle

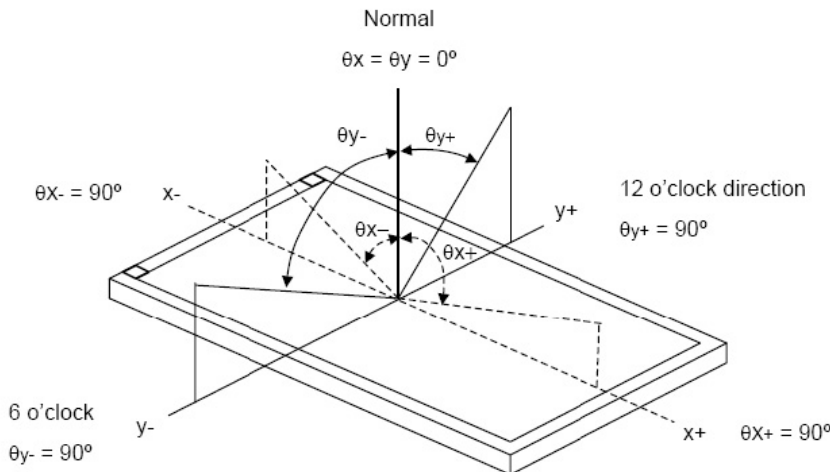

*3 Definition of response time

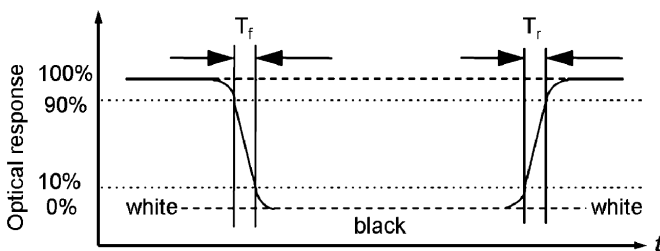

*4 Definition of Luminance Uniformity

Luminance uniformity (Lu)=

Min. Luminance form pt1~pt9 / Max Luminance form Pt1~pt9

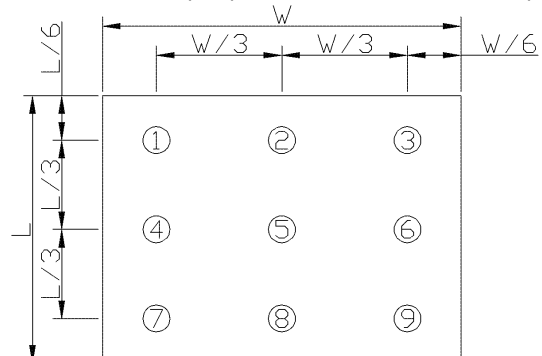

7. Touch panel Design Precautions

1. It should prevent front case touching the touch panel Active Area (A.A.) to prevent abnormal touch. It should left gab (e.g. 0.2~0.3mm) in between.

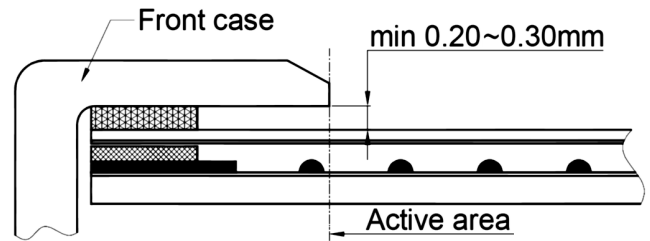

2. Outer case design should take care about the area outside the A.A. Those areas contain circuit wires which is having different thickness. Touching those areas could deform the ITO film. As a result case the ITO cold be damaged and shorten its lifetime. It is suggested to protect those areas with gasket (between the front case and the touch panel). The suggested figures are $B \geq 0.50\text{mm}$; $C \geq 0.50\text{mm}$.

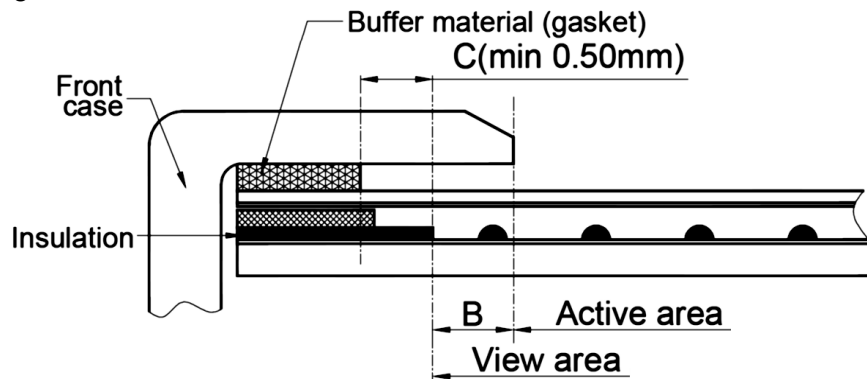

3. The front case side wall should keep space (e.g. 0.2 ~ 0.3mm) from the touch panel.

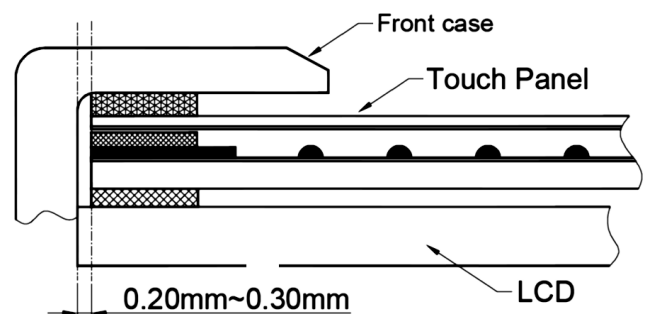

4. In general design, touch panel V.A. should be bigger than the LCD V.A. and touch panel A.A. should be bigger than the LCD A.A.

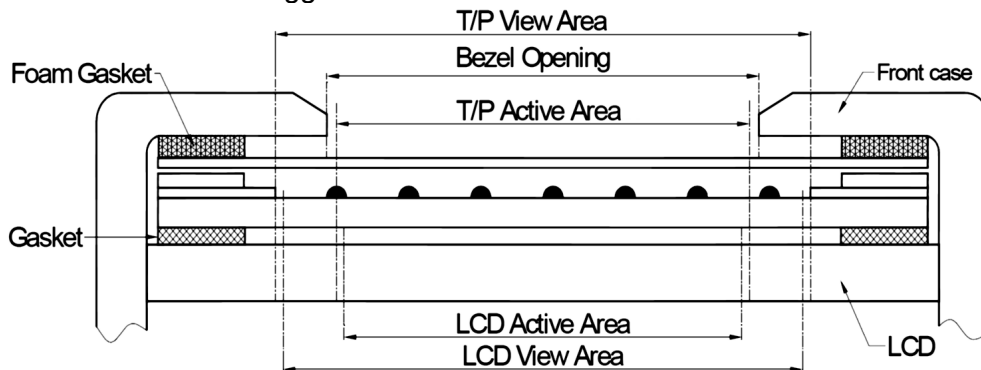

8. Precautions of using LCD Modules

Mounting

- Mounting must use holes arranged in four corners or four sides.
- The mounting structure so provide even force on to LCD module. Uneven force (ex. Twisted stress) should not applied to the module. And the case on which a module is mounted should have sufficient strength so that external force is not transmitted directly to the module.
- It is suggested to attach a transparent protective plate to the surface in order to protect the polarizer. It should have sufficient strength in order to the resist external force.
- The housing should adopt radiation structure to satisfy the temperature specification.
- Acetic acid type and chlorine type materials for the cover case are not desirable because the former generates corrosive gas of attacking the polarizer at high temperature and the latter causes circuit break by electro-chemical reaction.
- Do not touch, push or rub the exposed polarizers with glass, tweezers or anything harder than HB pencil lead. Never rub with dust clothes with chemical treatment. Do not touch the surface of polarizer for bare hand or greasy cloth.(Some cosmetics deteriorate the polarizer.)
- When the surface becomes dusty, please wipe gently with absorbent cotton or other soft materials like chamois soaks with petroleum benzine. Normal-hexane is recommended for cleaning the adhesives used to attach front / rear polarizers. Do not use acetone, toluene and alcohol because they cause chemical damage to the polarizer.
- Wipe off saliva or water drops as soon as possible. Their long time contact with polarizer

Operating

- The spike noise causes the mis-operation of circuits. It should be within the $\pm 200\text{mV}$ level (Over and under shoot voltage)
- Response time depends on the temperature.(In lower temperature, it becomes longer.)
- Brightness depends on the temperature. (In lower temperature, it becomes lower.) And in lower temperature, response time(required time that brightness is stable after turned on) becomes longer.
- Be careful for condensation at sudden temperature change. Condensation makes damage to polarizer or electrical contacted parts. And after fading condensation, smear or spot will occur.
- When fixed patterns are displayed for a long time, remnant image is likely to occur.
- Module has high frequency circuits. Sufficient suppression to the electromagnetic interference shall be done by system manufacturers. Grounding and shielding methods may be important to minimized the interference

Electrostatic Discharge Control

Since a module is composed of electronic circuits, it is not strong to electrostatic discharge. Make certain that treatment persons are connected to ground through wrist band etc. And don't touch interface pin directly.

Strong Light Exposure

Strong light exposure causes degradation of polarizer and color filter.

Storage

When storing modules as spares for a long time, the following precautions are necessary.

- Store them in a dark place. Do not expose the module to sunlight or fluorescent light. Keep the temperature between 5°C and 35°C at normal humidity.
- The polarizer surface should not come in contact with any other object. It is recommended that they be stored in the container in which they were shipped.

Protection Film

- When the protection film is peeled off, static electricity is generated between the film and polarizer. This should be peeled off slowly and carefully by people who are electrically grounded and with well ion-blown equipment or in such a condition, etc.
- The protection film is attached to the polarizer with a small amount of glue. If some stress is applied to rub the protection film against the polarizer during the time you peel off the film, the glue is apt to be main on the polarizer. Please carefully peel off the protection film without rubbing it against the polarizer.
- When the module with protection film attached is stored for a long time, sometimes there remains a very small amount of glue still on the polarizer after the protection film is peeled off.
- You can remove the glue easily. When the glue remains on the polarizer surface or its vestige is recognized, please wipe them off with absorbent cotton waste or other soft material like chamois soaked with normal-hexane.

Transportation

The LCD modules should be no falling and violent shocking during transportation, and also should avoid excessive press, water, damp and sunshine.