



深圳市拓普微科技开发有限公司

SHENZHEN TOPWAY TECHNOLOGY CO., LTD.

LMT101DNMFWD-AAN

LCD Module User Manual

Prepared by: Liu sanyong Date: 2017-10-12	Checked by: Date:	Approved by: Date:
--	----------------------------------	-----------------------------------

Rev.	Descriptions	Release Date
0.1	Preliminary release	2017-04-24
0.2	Enhance Operating Temperature with Product Name update	2017-10-12

Table of Content

1. General Specification	3
2. Block Diagram.....	3
3. Terminal Function.....	4
3.1 K1 LVDS Terminal	4
3.2 K2 BackLight Connector	4
4. Absolute Maximum Ratings.....	5
5. Electrical Characteristics.....	5
5.1 Driving TFT LCD Panel	5
5.2 LED Backlight Circuit Characteristics.....	5
5.3 Power On/Off Sequence	6
6. LVDS Signal timing characteristic	6
6.1 Electrical characteristics.....	6
6.2 LVDS input timing	7
6.3 Display colors and input data signal.....	7
7. Optical Characteristics.....	8
8. Precautions of using LCD Modules	9

1. General Specification

Signal Interface :	LVDS (18bit)
Display Mode :	Transmissive / Normal White
Screen Size(Diagonal) :	10.1"
Outline Dimension :	251.0 x 140.0x 11.5 (mm) (see attached drawing for details)
Active Area :	222.71 x 125.28 (mm)
Number of dots :	1024 x 600
Pixel Pitch :	0.2175 x 0.2088 (mm)
Pixel Configuration :	RGB Stripe
Backlight :	LED
Surface Treatment :	AG,HC,(3H)
Viewing Direction :	6 o'clock(*1)(gray-scale inverse) 12 o'clock(*2)
Operating Temperature :	-20 ~ +70°C
Storage Temperature :	-30 ~ +75°C

Note:

*1. For saturated color display content (eg. pure-red, pure-green, pure-blue, or pure-colors-combinations).

*2. For "color scales" display content.

*3. Color tone may slightly change by Temperature and Driving Condition.

2. Block Diagram

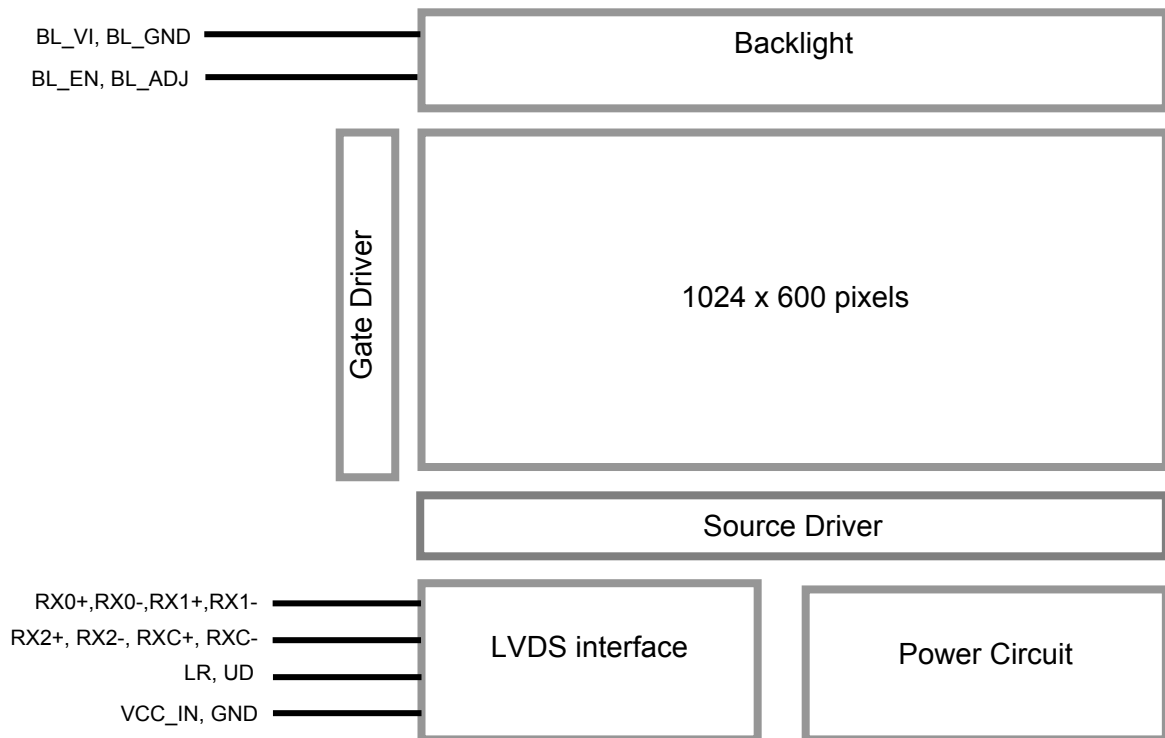

3. Terminal Function

3.1 K1 LVDS Terminal

Pin No.	Pin Name	IO	Descriptions
1	NC	-	No connection
2	NC	-	No connection
3	NC	-	No connection
4	NC	-	No connection
5	GND	Power	Ground
6	RXC+	Input	LVDS receiver negative signal clock
7	RXC-	Input	LVDS receiver positive signal clock
8	GND	Power	Ground
9	RX2+	Input	LVDS receiver negative signal channel 2
10	RX2-	Input	LVDS receiver positive signal channel 2
11	GND	Power	Ground
12	RX1+	Input	LVDS receiver negative signal channel 1
13	RX1-	Input	LVDS receiver positive signal channel 1
14	GND	Power	Ground
15	RX0+	Input	LVDS receiver negative signal channel 0
16	RX0-	Input	LVDS receiver positive signal channel 0
17	LR	Input	Display X-Flip Setting (*1)
18	UD	Input	Display Y-Flip Setting (*1)
19	VCC_IN	Power	Positive Power Supply
20	VCC_IN		

Note:

*1: Selection of scanning mode

Setting of scan control input		Scanning direction
UD	LR	
Low	High	Up to down, left to right(normal)
High	Low	Down to up, right to left
Low	Low	Up to down, right to left
High	High	Down to up, left to right

3.2 K2 BackLight Connector

Pin No.	Pin Name	IO	Descriptions
1	BL_VI	Power	Positive Power Supply
2	BL_ADJ	Input	Backlight dimming control(High actives) PWM may be used to adjust the output brightness
3	BL_EN	Input	Backlight Driver Control BLON=Hi, Backlight Driving Booster enable BLON=Lo, Backlight Driving Booster disable
4	BL_GND	Power	Power Supply GND (0V)

4. Absolute Maximum Ratings

Items	Symbol	Min.	Max.	Unit	Condition
Power Supply voltage	VCC_IN	2.8	+3.6	V	
Backlight Supply voltage	BL_Vi	-0.3	+15.0	V	
Operating Temperature	T _{OP}	-20	70	°C	No Condensation
Storage Temperature	T _{ST}	-30	75	°C	No Condensation
Operating and Storage Humidity	HSTG	10%	90%	%(RH)	

Note:

- *1. This rating applies to all parts of the module. And should not be exceeded.
- *2. The operating temperature only guarantees operation of the circuit. The contrast, response speed, and the other specification related to electro-optical display quality is determined at the room temperature, T_{OP}=25°C
- *3. Ambient temperature when the backlight is lit (reference value)
- *4. Any Stresses exceeding the Absolute Maximum Ratings may cause substantial damage to the device. Functional operation of this device at other conditions beyond those listed in the specification is not implied and prolonged exposure to extreme conditions may affect device reliability.

5. Electrical Characteristics

5.1 Driving TFT LCD Panel

Top=25°C, VCC_IN =3.3V ,GND=0V

Items	Symbol	MIN.	TYP.	MAX.	Unit	Note	
Supply Voltage	VCC_IN	3.0	3.3	3.6	V		
Input Signal Voltage	Low Level	V _{IL}	GND	--	0.2xVDD	V	LR,UD
	High Level	V _{IH}	0.8xVDD	--	VDD	V	LR,UD
VCC Power Consumption	I _{VCC-IN}	-	185	500	mA	*1	

Note.

- *1. Normal display condition

5.2 LED Backlight Circuit Characteristics

BL_GND=0V, T_{OP}=25°C

Parameter	Symbol	MIN.	TYP.	MAX.	Unit	Note
Operating Voltage	BL_VI	11.5	12.0	12.5	V	
Input High Voltage	V _{IH}	3.0	-	BL_VI	V	BL_EN, BL_ADJ
Input Low Voltage	V _{IL}	BL_GND	-	0.3	V	BL_EN, BL_ADJ
Operating Current(*1)	I _{BL_VI}	-	170	420	mA	BL_VI

Cautions:

Exceeding the recommended driving current could cause substantial damage to the backlight and shorten its lifetime.

Note:

- *1: BL_EN=Hi, BL_ADJ=Hi;
- *2: Recommended BL_ADJ PWM Freq. is 3kHz
- *3: Terminal circuit (Fig.1) :

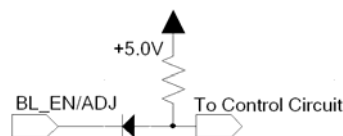
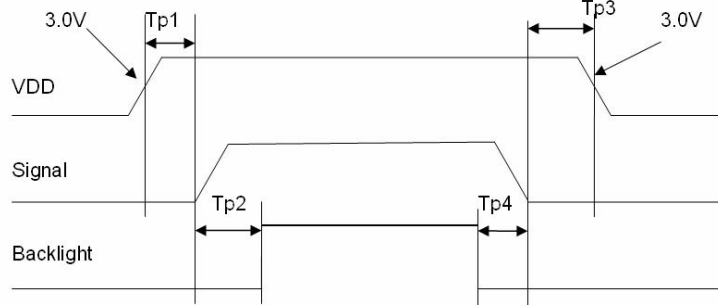

Fig.1 Terminal circuit

5.3 Power On/Off Sequence

Items	Symbol	MIN.	TYP.	Max.	Unit	Note
VDD 3.0V to signal starting	Tp1	0	-	50	ms	
Signal starting to backlight on	Tp2	150	-	-	ms	
Signal off to VDD 3.0V	Tp3	0	-	50	ms	
Backlight off to signal off	Tp4	150	-	-	ms	



Interface Power On/Off Sequence

6. LVDS Signal timing characteristic

6.1 Electrical characteristics

Item	Symbol	MIN.	TYP.	MAX.	Unit	Condition
Differential input high Threshold voltage	R_{XVTH}	-	-	+0.1	V	$R_{XVCOM}=1.2V$
Differential input low Threshold voltage	R_{XVTL}	-0.1	-	-	V	
Input voltage range (Singed-end)	R_{XVIN}	0	-	$VDD-1.2+ V_{ID} /2$	V	
Differential input Common Mode voltage	R_{XVCOM}	$ V_{ID} /2$	-	$VDD-1.2$	V	
Differential input voltage	$ V_{ID} $	0.2	-	0.6	V	
Differential input leakage Current	R_{VXLIZ}	-10	-	+10	μA	
LVDS digital operating Current	I_{ddlvs}	-	15	30	mA	Fclk=65MHz VDD=3.3v
LVDS digital stand-by Current	I_{stlvs}	-	10	50	μA	Clock & all functions are stopped

Single-end signals & Differential signals

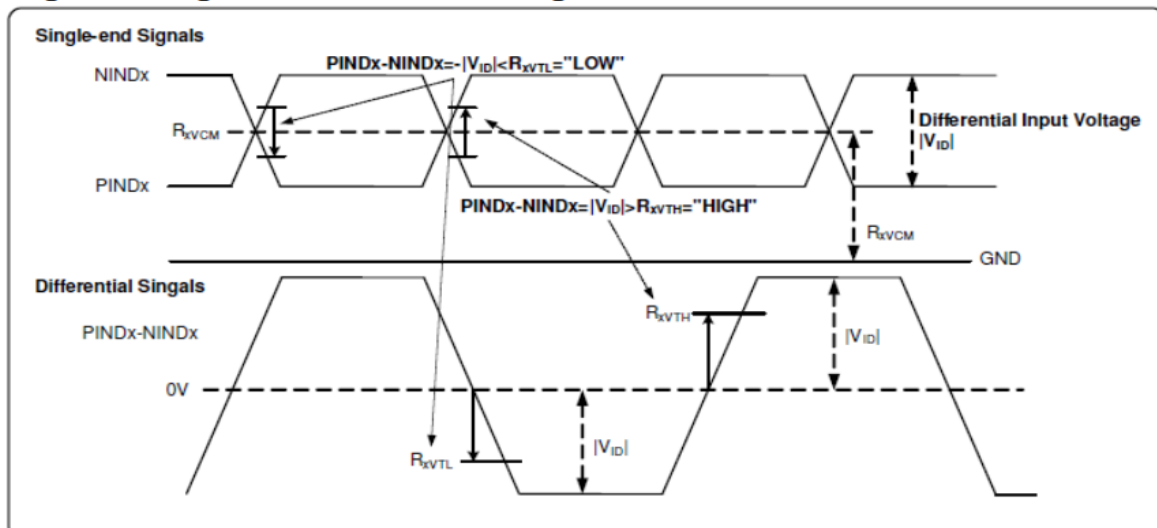

6.2 LVDS input timing

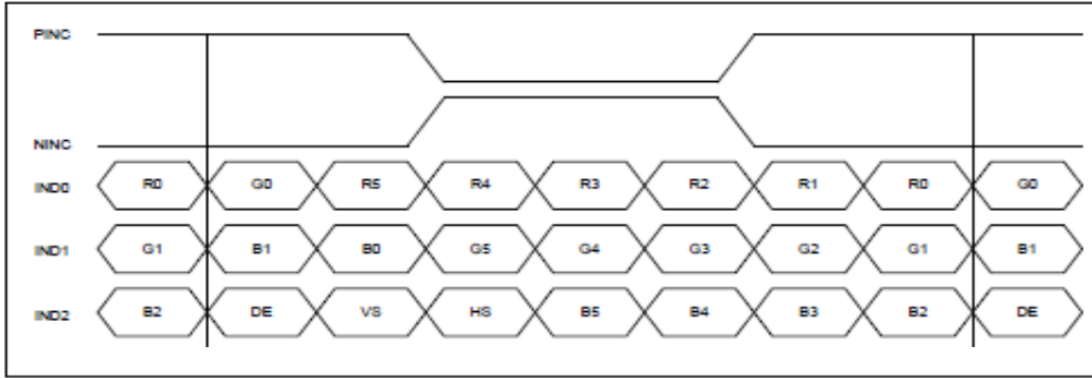

DE mode:

Item	Symbol	MIN.	TYP.	MAX.	Unit	Remark
DCLK Frequency	fclk	40.8	51.2	67.2	MHz	
Horizontal display area	thd	1024			DCLK	
HSD period	th	1114	1344	1400	DCLK	
HSD blanking	thb+thfp	90	320	376	DCLK	
Vertical display area	tvd	600			TH	
VSD period	Tv	610	635	800	TH	
VSD blanking	tvbp+tvfp	10	35	200	TH	

6.3 Display colors and input data signal

This product can display in equivalent to 16,777,216 colors in 256 gray scales. Also the relation between display colors and input data signals is as the following table.

Display colors		Data signal (0: Low level, 1: High level)																							
		R7	R6	R5	R4	R3	R2	R1	R0	G7	G6	G5	G4	G3	G2	G1	G0	B7	B6	B5	B4	B3	B2	B1	B0
Basic Colors	Black	0	0	0	0	0	0	0	0	0	0	0	0	0	0	0	0	0	0	0	0	0	0	0	0
	Blue	0	0	0	0	0	0	0	0	0	0	0	0	0	0	0	0	1	1	1	1	1	1	1	1
	Red	1	1	1	1	1	1	1	1	0	0	0	0	0	0	0	0	0	0	0	0	0	0	0	0
	Magenta	1	1	1	1	1	1	1	1	0	0	0	0	0	0	0	0	1	1	1	1	1	1	1	1
	Green	0	0	0	0	0	0	0	0	1	1	1	1	1	1	1	1	0	0	0	0	0	0	0	0
	Cyan	0	0	0	0	0	0	0	0	1	1	1	1	1	1	1	1	1	1	1	1	1	1	1	1
	Yellow	1	1	1	1	1	1	1	1	1	1	1	1	1	1	1	1	0	0	0	0	0	0	0	0
	White	1	1	1	1	1	1	1	1	1	1	1	1	1	1	1	1	1	1	1	1	1	1	1	1
Red gray scale	Black	0	0	0	0	0	0	0	0	0	0	0	0	0	0	0	0	0	0	0	0	0	0	0	0
	dark	0	0	0	0	0	0	0	1	0	0	0	0	0	0	0	0	0	0	0	0	0	0	0	0
	↑																								
	↓																								
	bright	1	1	1	1	1	1	0	1	0	0	0	0	0	0	0	0	0	0	0	0	0	0	0	0
Green gray scale	Black	0	0	0	0	0	0	0	0	0	0	0	0	0	0	0	0	0	0	0	0	0	0	0	0
	dark	0	0	0	0	0	0	0	0	0	0	0	0	0	0	0	1	0	0	0	0	0	0	0	0
	↑																								
	↓																								
	bright	0	0	0	0	0	0	0	0	1	1	1	1	1	1	0	1	0	0	0	0	0	0	0	0
Blue gray scale	Black	0	0	0	0	0	0	0	0	0	0	0	0	0	0	0	0	0	0	0	0	0	0	0	0
	dark	0	0	0	0	0	0	0	0	0	0	0	0	0	0	0	0	0	0	0	0	0	0	1	0
	↑																								
	↓																								
	bright	0	0	0	0	0	0	0	0	0	0	0	0	0	0	0	0	1	1	1	1	1	1	0	1

7. Optical Characteristics

Item	Symbol	Condition	MIN.	TYP.	MAX.	UNIT	Note.
Viewing angle (CR ≥ 10)	θ_L	9 o'clock	70	80	-	degree	*2
	θ_R	3 o'clock	70	80	-		
	θ_T	12 o'clock	65	75	-		
	θ_B	6 o'clock	70	80	-		
Response Time	T_f	Normal $\theta=0^\circ$	-	7	10	msec	*3
	T_r		-	9	18	msec	
Contrast ratio	CR		600	800	-	-	*1
Color chromaticlty	W_X		0.241	0.281	0.321	-	
	W_Y		0.260	0.300	0.340	-	
Luminance	L		250	300	-	cd/m ²	*4
Luminance uniformity	Y_U		70	80	-	%	*4

Note:

***1. Definition of Contrast Ratio**

The contrast ratio could be calculate by the following expression:

Contrast Ratio (CR) = Luminanc with all pixels white / Luminance with all pixels black

***2 Definition of Viewing Angle**

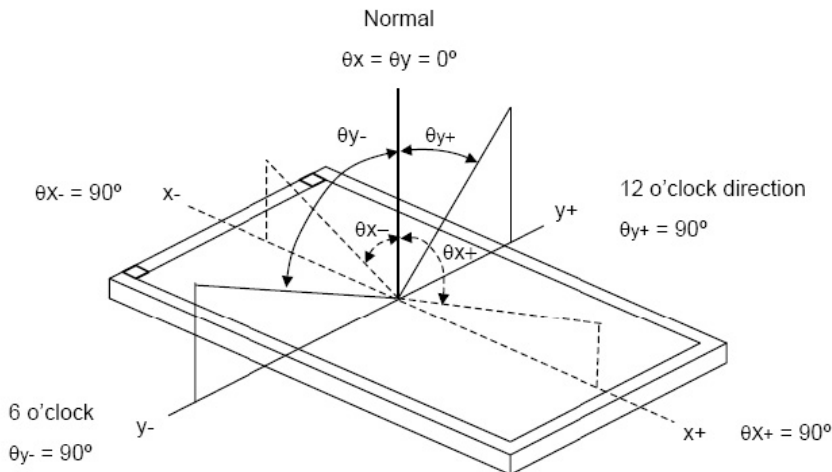

***3 Definition of response time**

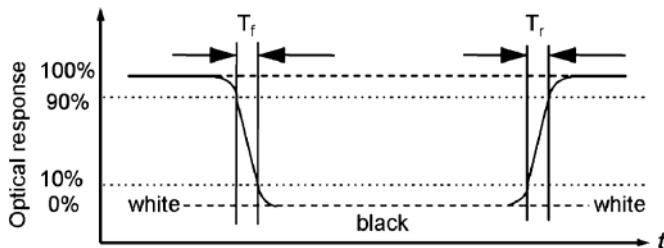

***4 Definition of Luminance Uniformity**

Luminance uniformity (Lu)=

Min. Luminance form pt1~pt9 / Max Luminance form Pt1~pt9

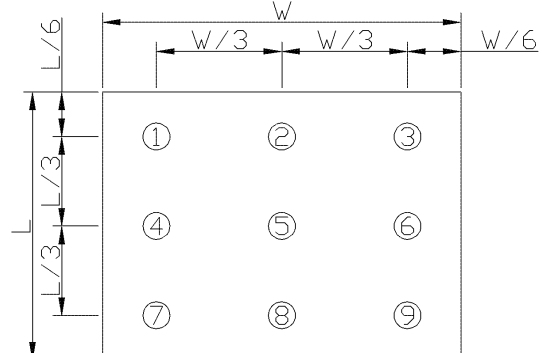

8. Precautions of using LCD Modules

Mounting

- Mounting must use holes arranged in four corners or four sides.
- The mounting structure so provide even force on to LCD module. Uneven force (ex. Twisted stress) should not applied to the module. And the case on which a module is mounted should have sufficient strength so that external force is not transmitted directly to the module.
- It is suggested to attach a transparent protective plate to the surface in order to protect the polarizer. It should have sufficient strength in order to the resist external force.
- The housing should adopt radiation structure to satisfy the temperature specification.
- Acetic acid type and chlorine type materials for the cover case are not desirable because the former generates corrosive gas of attacking the polarizer at high temperature and the latter causes circuit break by electro-chemical reaction.
- Do not touch, push or rub the exposed polarizers with glass, tweezers or anything harder than HB pencil lead. Never rub with dust clothes with chemical treatment. Do not touch the surface of polarizer for bare hand or greasy cloth.(Some cosmetics deteriorate the polarizer.)
- When the surface becomes dusty, please wipe gently with absorbent cotton or other soft materials like chamois soaks with petroleum benzine. Normal-hexane is recommended for cleaning the adhesives used to attach front / rear polarizers. Do not use acetone, toluene and alcohol because they cause chemical damage to the polarizer.
- Wipe off saliva or water drops as soon as possible. Their long time contact with polarizer

Operating

- The spike noise causes the mis-operation of circuits. It should be within the $\pm 200\text{mV}$ level (Over and under shoot voltage)
- Response time depends on the temperature.(In lower temperature, it becomes longer.)
- Brightness depends on the temperature. (In lower temperature, it becomes lower.) And in lower temperature, response time(required time that brightness is stable after turned on) becomes longer.
- Be careful for condensation at sudden temperature change. Condensation makes damage to polarizer or electrical contacted parts. And after fading condensation, smear or spot will occur.
- When fixed patterns are displayed for a long time, remnant image is likely to occur.
- Module has high frequency circuits. Sufficient suppression to the electromagnetic interference shall be done by system manufacturers. Grounding and shielding methods may be important to minimized the interference

Electrostatic Discharge Control

Since a module is composed of electronic circuits, it is not strong to electrostatic discharge. Make certain that treatment persons are connected to ground through wrist band etc. And don't touch interface pin directly.

Strong Light Exposure

Strong light exposure causes degradation of polarizer and color filter.

Storage

When storing modules as spares for a long time, the following precautions are necessary.

- Store them in a dark place. Do not expose the module to sunlight or fluorescent light. Keep the temperature between 5°C and 35°C at normal humidity.
- The polarizer surface should not come in contact with any other object. It is recommended that they be stored in the container in which they were shipped.

Protection Film

- When the protection film is peeled off, static electricity is generated between the film and polarizer. This should be peeled off slowly and carefully by people who are electrically grounded and with well ion-blown equipment or in such a condition, etc.
- The protection film is attached to the polarizer with a small amount of glue. If some stress is applied to rub the protection film against the polarizer during the time you peel off the film, the glue is apt tore main on the polarizer. Please carefully peel off the protection film without rubbing it against the polarizer.
- When the module with protection film attached is stored for a long time, sometimes there remains a very small amount of glue still on the polarizer after the protection film is peeled off.
- You can remove the glue easily. When the glue remains on the polarizer surface or its vestige is recognized, please wipe them off with absorbent cotton waste or other soft material like chamois soaked with normal-hexane.

Transportation

The LCD modules should be no falling and violent shocking during transportation, and also should avoid excessive press, water, damp and sunshine.

