



# LMT104SBH01-NNC

## LCD Module User Manual

Prepared by:  <b>HT LIU</b>  Date: 2016-04-05	Checked by:    Date:	Approved by:    Date:
---	----------------------------------	-----------------------------------

Rev.	Descriptions	Release Date
0.1	Preliminary	2011-09-07
0.2	Typing Correction On Driving Backlight Note 2	2012-06-28
0.3	Revise Luminance	2016-4-5

**Table of Content**

<b>1. General Specification .....</b>	<b>3</b>
<b>2. Block Diagram.....</b>	<b>3</b>
<b>3. Input/Output Terminals .....</b>	<b>4</b>
3.1 TFT LCD Panel .....	4
3.2 CN2 (Backlight connector) .....	4
3.3 CN3 (TP FPC).....	4
<b>4. Absolute Maximum Ratings.....</b>	<b>5</b>
<b>5. Electrical Characteristics.....</b>	<b>5</b>
5.1 Driving TFT LCD Panel .....	5
5.2 Driving Backlight .....	6
<b>6. AC Characteristics.....</b>	<b>7</b>
6.1 Timing Conditions .....	7
<b>7. Optical Characteristics.....</b>	<b>8</b>

## 1. General Specification

Signal Interface :	LVDS 6 bits
Display Technology :	a-Si TFT active matrix
Display Mode :	TN Type Full Color / Transmissive / Normal White
Screen Size(Diagonal) :	10.4 inch
Outline Dimension :	236.00x176.90x7.3 (mm)
Active Area :	211.20x158.40 (mm)
Number of dots :	800x 3 (RGB) x 600
Dot Pitch :	0.264x0.264 (mm)
Pixel Configuration :	R.G.B. Vertical Stripe
Backlight :	LED Backlight
Surface Treatment :	Anti-Glare
Viewing Direction :	12 o'clock
Operating Temperature :	-20 ~ +70°C
Storage Temperature :	-30 ~ +80°C

## 2. Block Diagram

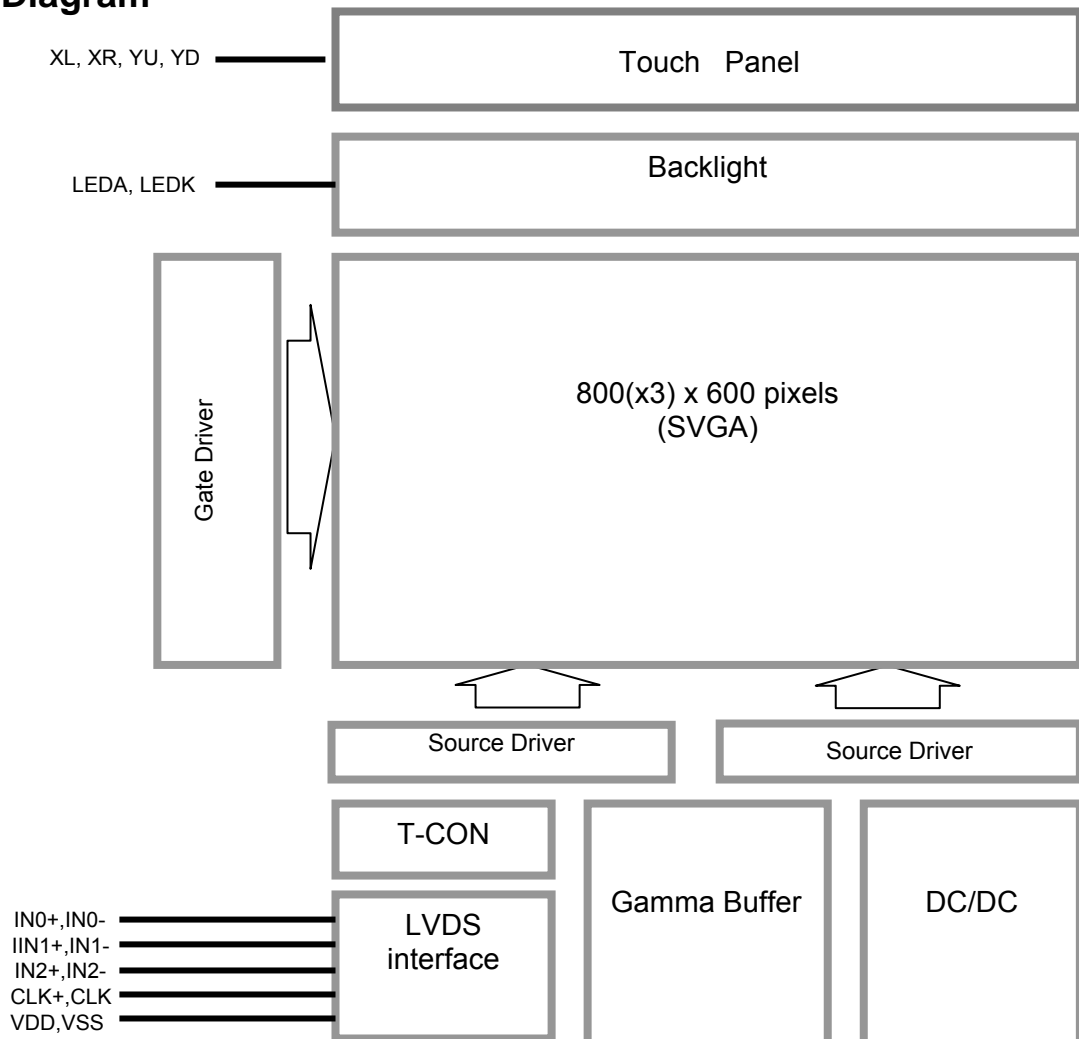

### 3. Input/Output Terminals

#### 3.1 TFT LCD Panel

Pin No.	Pin Name	IO	Descriptions
1	VDD	Power	Power Supply
2			
3	GND	Power	Ground
4			
5	IN0-	Input	LVDS receiver negative signal channel 0
6	IN0+	Input	LVDS receiver positive signal channel 0
7	GND	Power	Ground
8	IN1-	Input	LVDS receiver negative signal channel 1
9	IN1+	Input	LVDS receiver positive signal channel 1
10	GND	Power	Ground
11	IN2-	Input	LVDS receiver negative signal channel 2
12	IN2+	Input	LVDS receiver positive signal channel 2
13	GND	Power	Ground
14	CLK-	Input	LVDS receiver negative signal clock
15	CLK+	Input	LVDS receiver positive signal clock
16	GND	Power	Ground
17	NC	-	No connection
18			
19	GND	Power	Ground
20			

#### 3.2 CN2 (Backlight connector)

Pin No.	Pin Name	IO	Descriptions	Wire Color
1	LEDA	Power	LED driving anode (high voltage)	Red
2	LEDK	Power	LED driving cathode (low voltage)	White

#### 3.3 CN3 (TP FPC)

No.	Symbol	IO	Descriptions	Remark
1	Y2	I	Down Side sense Terminal	
2	X1	I	Left Side sense Terminal	
3	Y1	I	Up Side sense Terminal	
4	X2	I	Right Side sense Terminal	

### 4. Absolute Maximum Ratings

GND=0V, T<sub>OP</sub>=25°C

Items	Symbol	Min.	Max.	Unit	Condition
Power Voltage	VDD	-0.3	+5.0	V	GND = 0V
Input voltage	V <sub>IN</sub>	-0.3	+5.0	V	GND= 0V
Operating Temperature	T <sub>OP</sub>	-20	+70	°C	No Condensation
Storage Temperature	T <sub>ST</sub>	-20	+70	°C	No Condensation

Note1: V<sub>IN</sub> represent IN0±, IN1±, IN2±, CLK±

### 5. Electrical Characteristics

#### 5.1 Driving TFT LCD Panel

GND=0V, V<sub>DD</sub>=3.3V, T<sub>OP</sub>=25°C

Items	Symbol	MIN.	TYP.	MAX.	Unit	Note
LVDS Differential input high threshold	V <sub>TH</sub>	-	-	+100	mV	V <sub>CMLVDS</sub> =1.2V
LVDS Differential input low threshold	V <sub>TL</sub>	-100	-	-	mV	V <sub>CMLVDS</sub> =1.2V
Differential input voltage	V <sub>ID</sub>	0.1	-	0.6	V	
LVDS input common mode voltage	V <sub>CMLVDS</sub>	V <sub>ID</sub>  /2	-	1.4-( V <sub>ID</sub>  /2)	V	
Input current	I <sub>IN</sub>	-10	-	10	μA	
Supply Voltage	VDD	3.0	3.3	3.6	V	
Common Electrode Driving Signal	VCOM	-	4.36	-	V	Note1
Sync Frequency	FVD		60	70	Hz	
VDD Power Consumption	I <sub>DD</sub>	-	260	380	mA	Note2

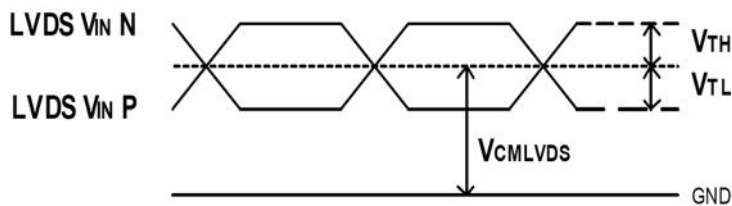

LVDS DC timing diagram

Note1: The value may be different for different LCM.

Note2: To test the current dissipation, using the “color bar” testing pattern shown as below:

- 1. White
- 2. Yellow
- 3. Cyan
- 4. Green
- 5. Magenta
- 6. Red
- 7. Blue
- 8. Black

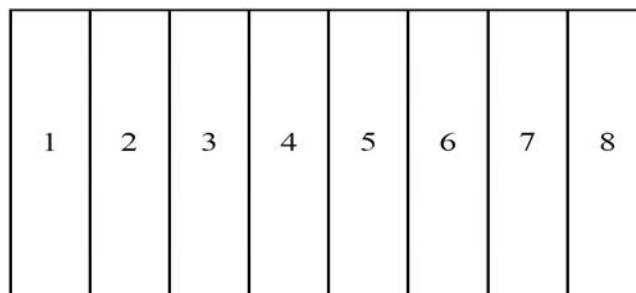

Current dissipation testin pattern

5.2 Driving Backlight

T<sub>OP</sub>=25°C

Parameter	Symbol	MIN.	TYP.	MAX.	Unit	Note
Forward Current	I <sub>F</sub> -	-	120	-	mA	
Forward Current Voltage	V <sub>F</sub>	-	19.2	-	V	
Backlight Power Consumption	W <sub>BL</sub> -	-	2.3	-	W	

Note 1: The figure below shows the connection of backlight LED.

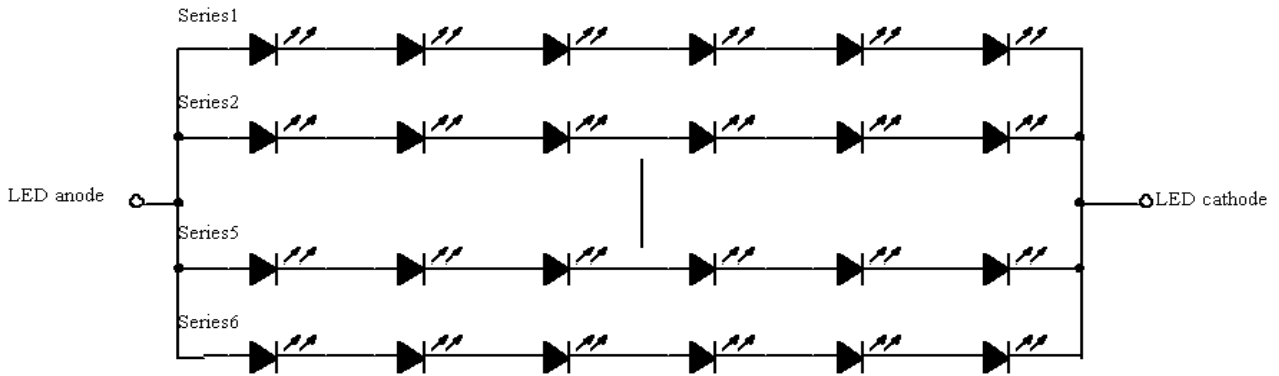

Note2: One LED: I<sub>F</sub>(1/6) =20mA.

Note3: The Life of LED is 20,000hrs.

Power On/Off Sequence

Items	Symbol	MIN.	TYP.	MAx.	Unit	Note
VDD 3.0V to signal starting	Tp1	0	-	50	ms	
Signal starting to backlight on	Tp2	150	-	-	ms	
Signal off to VDD 3.0V	Tp3	0	-	50	ms	
Backlight off to signal off	Tp4	150	-	-	ms	

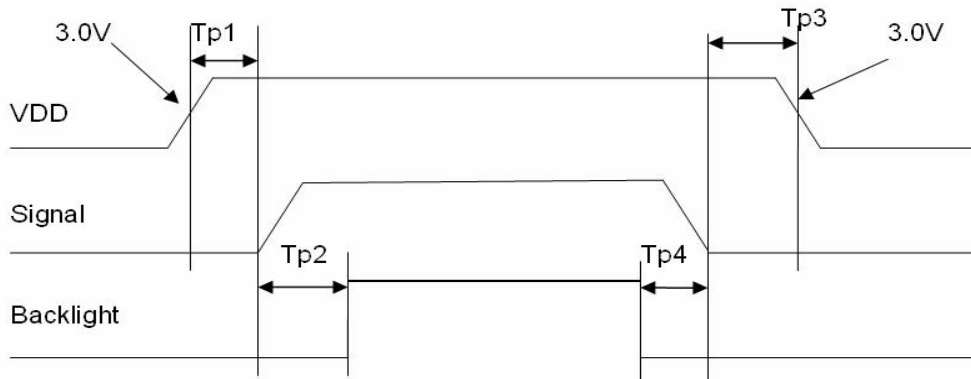

Interface Power On/Off Sequence

## 6. AC Characteristics

### 6.1 Timing Conditions

Item	Symbol	MIN.	TYP.	MAX.	Unit	Condition
Clock period	tLVCP	20.0	25	31.25	ns	
Clock high time	tLVCH	-	14.29	-	ns	
Clock low time	tLVCL	-	10.71	-	ns	
PLL wake-up time	tLVPLL	-	-	1	ms	
Input skew margin	tLVSKM	400	-	-	ps	f=85MHz

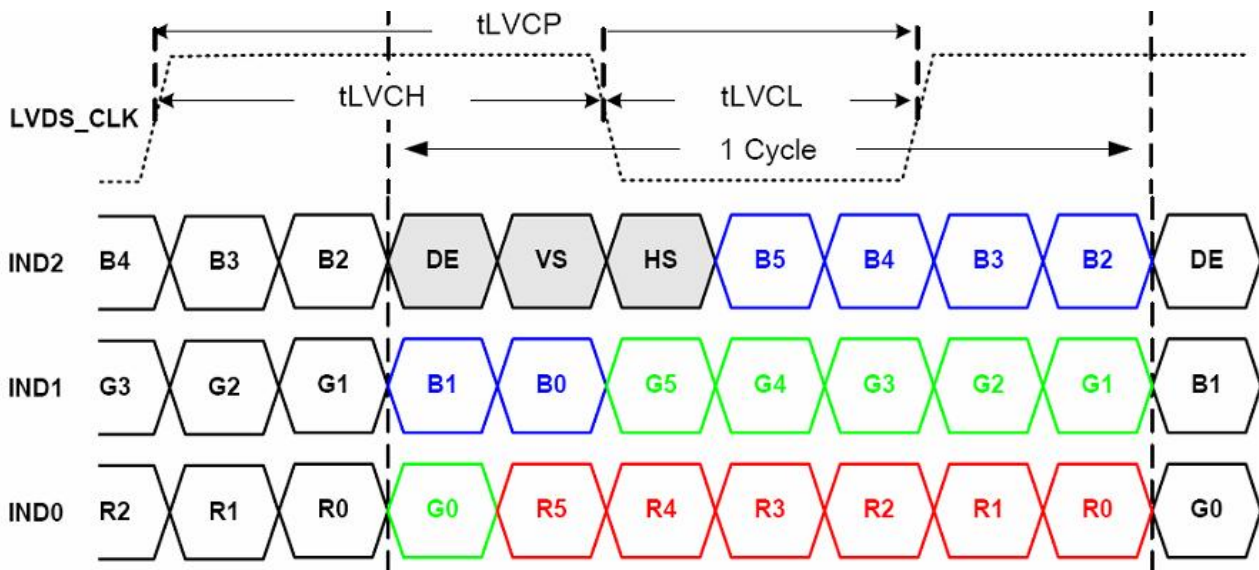
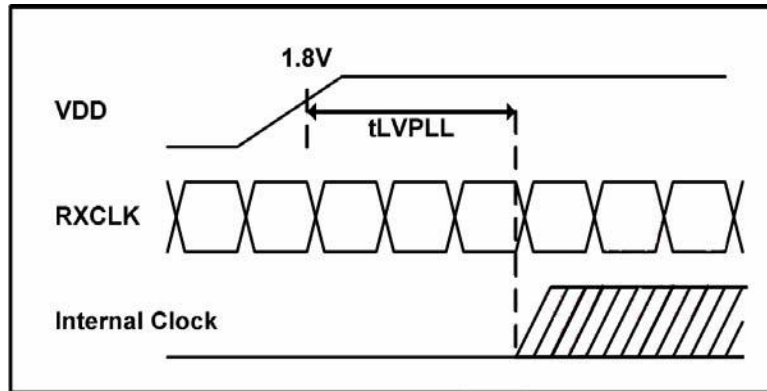

timing parameter

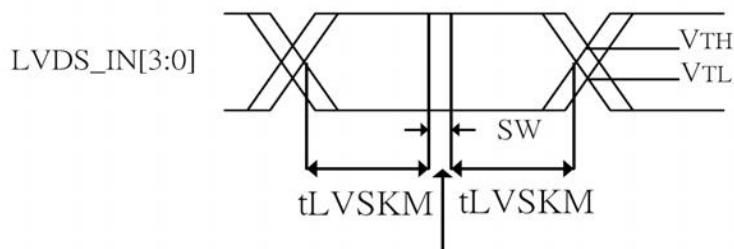

Ideal Strobe Position

SW: Setup and Hold time

Input signal data timing

## 7. Optical Characteristics

Ta=25°C

Item	Symbol	Condition	Min	TYP.	MAX.	UNIT	Note.	
View Angles	$\theta T$	CR 10	45	50	-	Degree	Note 2	
	$\theta B$		60	65	-			
	$\theta L$		60	65	-			
	$\theta R$		60	65	-			
Contrast Ratio	CR	$\theta=0^\circ$	300	400	-	-	Note1 Note3	
Response Time	$T_{ON}$	25°C	-	10	15	ms	Note1	
	$T_{OFF}$		-	15	25		Note4	
Chromaticity	White	Backlight is on	X	0.271	0.321	0.371		Note5 Note1
			Y	0.293	0.343	0.393		
	Red		X	0.545	0.595	0.645		
			Y	0.308	0.358	0.408		
	Green		X	0.286	0.336	0.386		
			Y	0.510	0.560	0.610		
	Blue		X	0.098	0.148	0.198		
			Y	0.075	0.125	0.175		
Uniformity	U	-	-	80	-	%	Note1 Note6	
NTSC	-	-	-	50	-	%	Note 5	
Luminance	L	-	-	300	-	cd/m <sup>2</sup>	Note1 Note7	

Test Conditions:

1. The ambient temperature is 25±2°C .humidity is 65±7%
2. The test systems refer to Note 1 and Note 2.



**Note 1:** Definition of optical measurement system.

The optical characteristics should be measured in dark room. After 5 minutes operation, the optical properties are measured at the center point of the LCD screen. All input terminals LCD panel must be ground when measuring the center area of the panel.

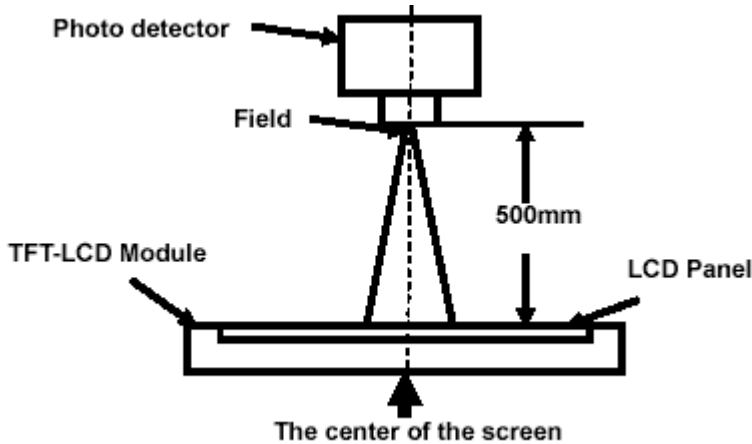

Item	Photo detecto	Field
Contrast Ratio	SR-3A	1°
Luminance		
Chromaticity		
Lum Uniformity	BM-7A	2°
Response Time		

**Note 2:** Definition of viewing angle range and measurement system

viewing angle is measured at the center point of the LCD by CONOSCOPE(ergo-80).

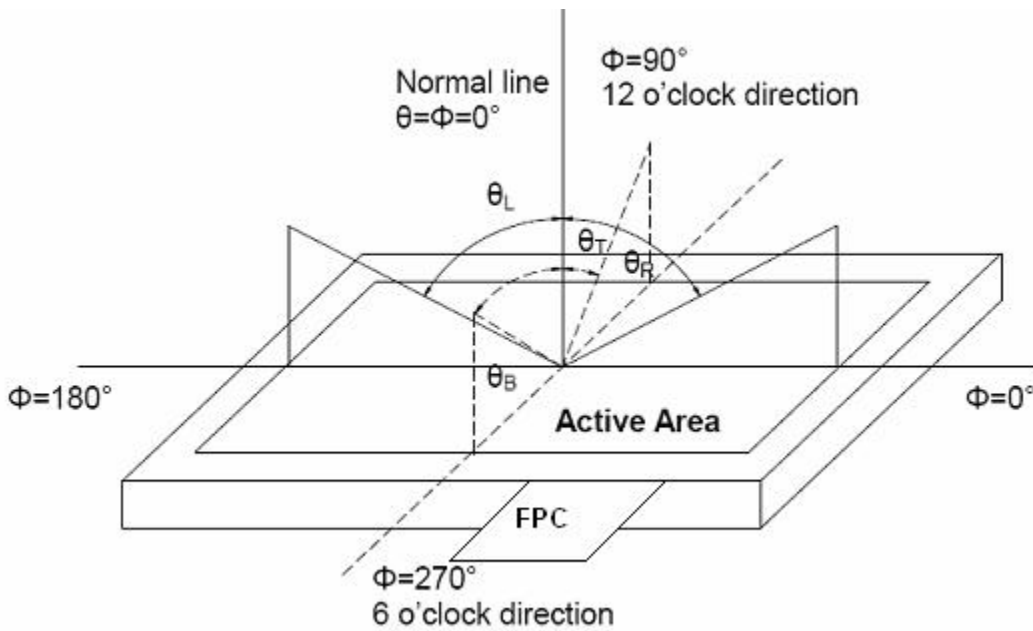

**Note 3: Definition of contrast ratio**

$$\text{Contrast ratio (CR)} = \frac{\text{Luminance measured when LCD is on the "White" state}}{\text{Luminance measured when LCD is on the "Black" state}}$$

White state “: The state is that the LCD should driven by Vwhite.

“Black state”: The state is that the LCD should driven by Vblack.

Vwhite: To be determined    Vblack: To be determined.

**Note 4: Definition of Response time**

The response time is defined as the LCD optical switching time interval between “White” state and “Black” state. Rise time (TON) is the time between photo detector output intensity changed from 90% to 10%. And fall time (TOFF) is the time between photo detector output intensity changed from 10% to 90%.

**Note 4: Definition of Response time**

The response time is defined as the LCD optical switching time interval between “White” state and “Black” state. Rise time (TON) is the time between photo detector output intensity changed from 90% to 10%. And fall time (TOFF) is the time between photo detector output intensity changed from 10% to 90%.

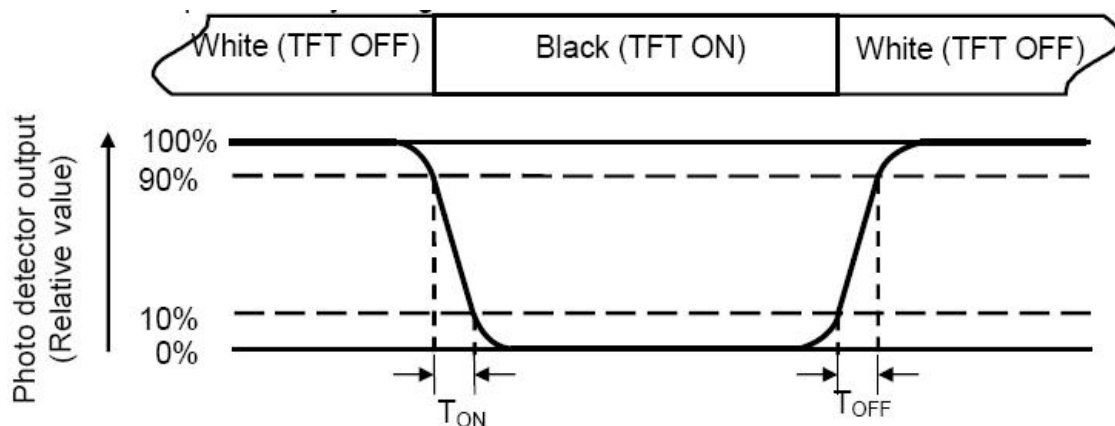
**Note 5: Definition of color chromaticity (CIE1931)**

Color coordinates measured at center point of LCD.

**Note 6: Definition of Luminance Uniformity**

Active area is divided into 9 measuring areas (Refer Fig. 2). Every measuring point is placed at the center of each measuring area.

$$\text{Luminance Uniformity}(U) = L_{\min} / L_{\max}$$

L-----Active area length W----- Active area width

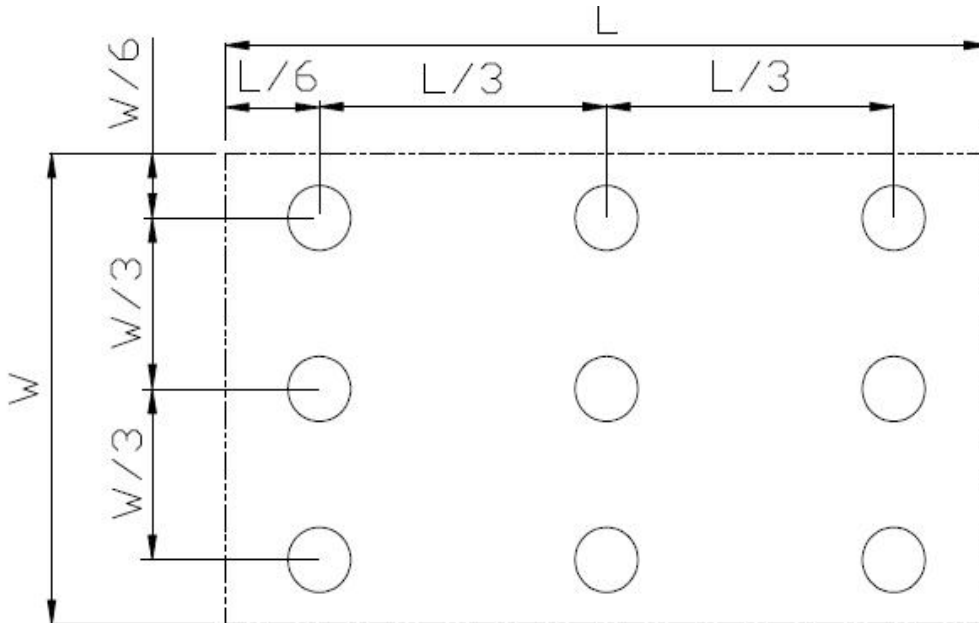

Definition of uniformity

$L_{\max}$ : The measured maximum luminance of all measurement position.

$L_{\min}$ : The measured minimum luminance of all measurement position.

**Note 7: Definition of Luminance :**

Measure the luminance of white state at center point.