



LMT121DNGFWD

LCD Module User Manual

Prepared by: Zhang Yu Date: 2014-11-13	Checked by: Date:	Approved by: Date:
---	----------------------------------	-----------------------------------

Rev.	Descriptions	Release Date
0.1	Preliminary	2014-11-13

Table of Content

1. General Specification.....	3
2. Block Diagram.....	3
3. Input/Output Terminals.....	4
3.1 K1 TFT Terminals.....	4
3.2 K2 BackLight Terminals.....	4
4. Absolute Maximum Ratings.....	5
5. Electrical Characteristics.....	5
5.1 Driving TFT LCD Panel.....	5
5.2 LED Backlight Circuit Characteristics.....	6
5.3 Power supply voltage Sequence.....	6
6. AC Characteristics.....	7
6.1 Input data mapping.....	7
6.2 Timing Characteristics.....	8
6.3 Input signal timing chart.....	9
7. Optical Characteristics.....	10
8. Precautions of using LCD Modules.....	12

1. General Specification

Signal Interface :	LVDS
Display Technology :	a-Si TFT active matrix
Display Mode :	TN Type Full Color / Transmissive / Normal White
Screen Size :	12.1 inch (Diagonal)
Outline Dimension :	279.0x209.0x9.0 (mm) (see Outline DWG for details)
Active Area :	245.76 x184.32 (mm)
Number of dots :	1024 x 768
Dot Pitch :	0.240 x 0.240(mm)
Pixel Configuration :	R.G.B. Vertical Stripe
Backlight :	White LED
Surface Treatment :	Anti-Glare
Viewing Direction :	6 o'clock
Operating Temperature :	-20 ~ +70°C
Storage Temperature :	-30 ~ +80°C

2. Block Diagram

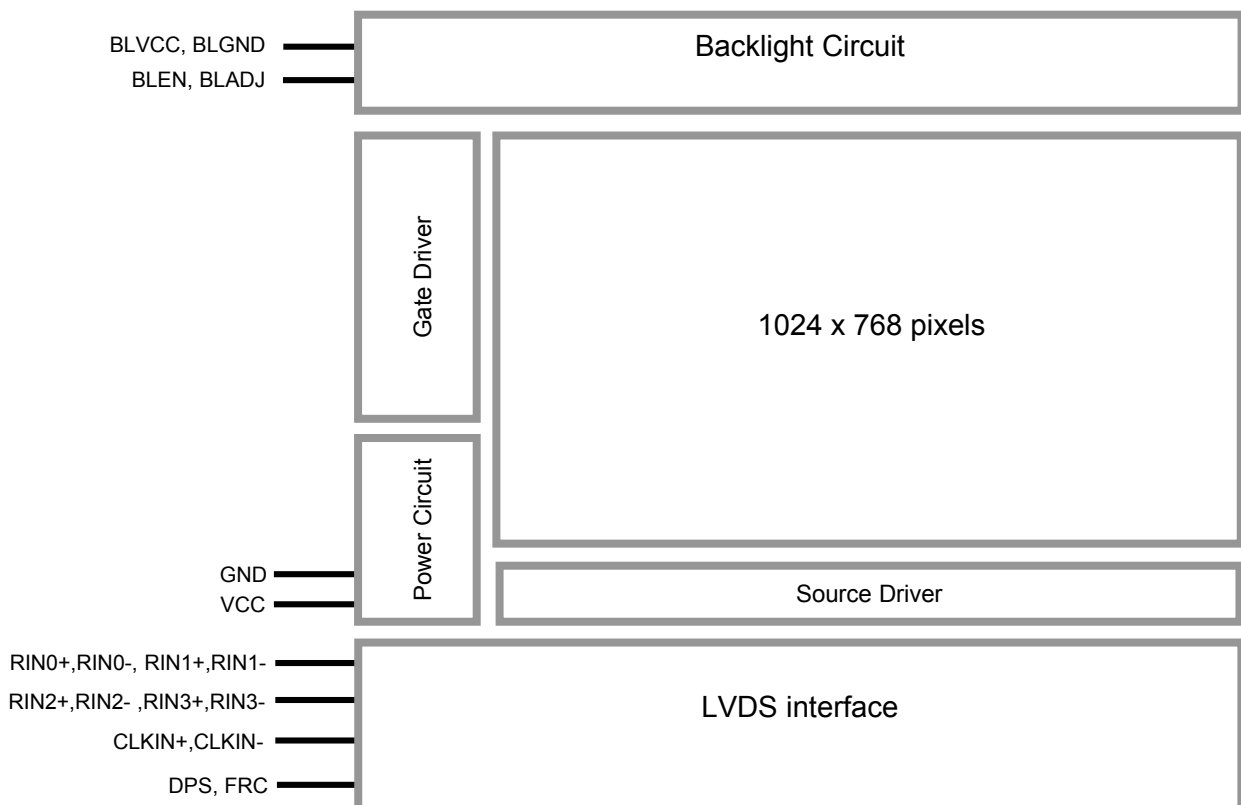

3. Input/Output Terminals

3.1 K1 TFT Terminals

Pin No.	Pin Name	IO	Descriptions	
			24Bit Mode	18Bit Mode
1	VCC	Power	Power Supply	
2				
3	GND	Power	Ground	
4	FRC	Input	H:8Bits LVDS Input (24bit mode)	L/NC: 6Bits LVDS Input (18bit mode)
5	RIN0-	Input	LVDS receiver negative signal channel 0	
6	RIN0+	Input	LVDS receiver positive signal channel 0	
7	GND	Power	Ground	
8	RIN1-	Input	LVDS receiver negative signal channel 1	
9	RIN1+	Input	LVDS receiver positive signal channel 1	
10	GND	Power	Ground	
11	RIN2-	Input	LVDS receiver negative signal channel 2	
12	RIN2+	Input	LVDS receiver positive signal channel 2	
13	GND	Power	Ground	
14	CLKIN-	Input	LVDS receiver negative signal clock	
15	CLKIN+	Input	LVDS receiver positive signal clock	
16	GND	Power	Ground	
17	RIN3-	Input	LVDS receiver negative signal channel 3.(Used for 8Bits LVDS Input; GND for 6Bits)	
18	RIN3+	Input	LVDS receiver positive signal channel 3.(Used for 8Bits LVDS Input; GND for 6Bits)	
19	DPS	Input	Display Reversed Function (H: Display Reverse; L/NC: Normal Display)	
20	NC	--	No Connection	

3.2 K2 BackLight Terminals

Pin No.	Pin Name	IO	Descriptions
1	NC	-	No Connection
2	BLADJ	Input	Backlight dimming control PWM may be used to adjust the output brightness
3	BLEN	Input	Backlight Driver Control BLEN=Hi, Backlight Driving Booster enable BLEN=Lo, Backlight Driving Booster disable
4	BLGND	Power	Power Supply GND (0V)
5	BLVCC	Power	Positive Power Supply

4. Absolute Maximum Ratings

GND=0V, T_{OP}=25°C

Items		Symbol	Rating	Unit	Remarks	
Power supply voltage	LCD panel signal processing board	VCC	-0.3 to +3.96	V	Ta= 25°C	
	LED driver	BLVCC	-0.3 to (+15.0)			
Input voltage for signals	Display signals ,Note1	VD	-0.5 to 3.96	V		
	Function signals ,Note2	VF	-0.5 to 3.96	V		
	Function signal for LED driver	BLADJ	-0.3 to (+15.0)	V		
		BLEN	-0.3 to (+15.0)	V		
Storage temperature		Tst	-30 to +80	°C		-
Operating temperature	Front surface	TopF	-20 to +70	°C		Note3
	Rear surface	TopR	-20 to +70	°C	Note4	
Relative humidity Note5		RH	90	%	Ta ≤ 40°C	
			85	%	40°C < Ta ≤ 50°C	
Absolute humidity ,Note5		AH	70,Note6	g/m3	Ta > 50°C	

Note1:RIN0±,RIN1±,RIN2±,RIN3± and CLKIN±;

Note2:DPS and FRC;

Note3:Measured at LCD panel surface (including self-heat);

Note4:Measured at LCD module's rear shield surface (including self-heat);

Note5:No condensation;

Note6:Water amount at Ta= 50°C and RH= 85%.

5. Electrical Characteristics

5.1 Driving TFT LCD Panel

GND=0V, VCC=3.3V, T_{OP}=25°C

Items	Symbol	MIN.	TYP.	MAX.	Unit	Note
Power supply voltage	VCC	3.0	3.3	3.96	V	
Power supply current	ICC	-	300	480	mA	*1
Permissible ripple voltage	VRP	-	-	300	mV	
Differential input threshold voltage for LVDS receiver	VTL	-100	-	-	mV	VCM=1.25V,*2
	VTH	-	-	100	mV	
Terminating resistor	RT	-	100	-	Ω	
Input voltage for DPS and FRC signals	VFH	0.7VCC	-	VCC	V	
	VFL	0	-	0.3VCC	V	

*1: All black pattern

*2: Common mode voltage for LVDS receiver

5.2 LED Backlight Circuit Characteristics

BLGND=0V ,T_{OP}=25°C

Parameter	Symbol	MIN.	TYP.	MAX.	Unit	Note
Power supply voltage	BLVCC	10.8	12.0	12.6	V	Note 1
Power supply voltage	I _{BLVCC}	-	430	650 Note2	mA	At the maximum luminance control
Permissible ripple voltage	VRPD	-	-	200	mVp-p	For BLVCC,Note3
Input voltage for PWM signal	VDFH1	2.0	-	BLVCC	V	
	VDFL1	0	-	0.8	V	
Input voltage for BLEN signal	VDFH2	2.0	-	BLVCC	V	
	VDFL2	0	-	0.8	V	
PWM Input Frequency	f _{PWM}	200	-	20k	Hz	Note4,Note5
PWM duty ratio	DR _{PWM}	1	-	100	%	Note6,Note7
PWM pulse width	t _{PWH}	5	-	-	us	

Note1:When designing of the power supply ,take the measures for the prevention of surge voltage.

Note2:This value excludes peak current such as overshoot current.

Note3:This power supply lines(BLVCC and GND)may have ripple voltage during luminance control of LED.There is the possibility that the ripple voltage produces acoustic noise and signal wave noise in audio circuit and so on.Put a capacitor between the power supply lines(BLVCC and GND) to reduce the noise is necessary .

Note4:A recommended f_{PWM} value is as follows.

$$f_{P_{WM}} = \frac{2n-1}{4} \times f_v$$

(n =integer,f_v =frame frequency of LCD module)

Note5:Depending on the frequency used ,some noise may appear on the screen,please conduct a thorough evaluation,

Note6:While the BLEN signal is high ,do not set the t_{PWH}(PWM pulse width) is less than 5us .It may cause abnormal working is the backlight .In this case,turn the backlight off and then on again by BLEN signal.

Note7:Regardless of the PWM frequency,both PWM duty ratio and PWM pulse width must be always more than the minimum values.

5.3 Power supply voltage Sequence

5.3.1 LCD panel signal processing board

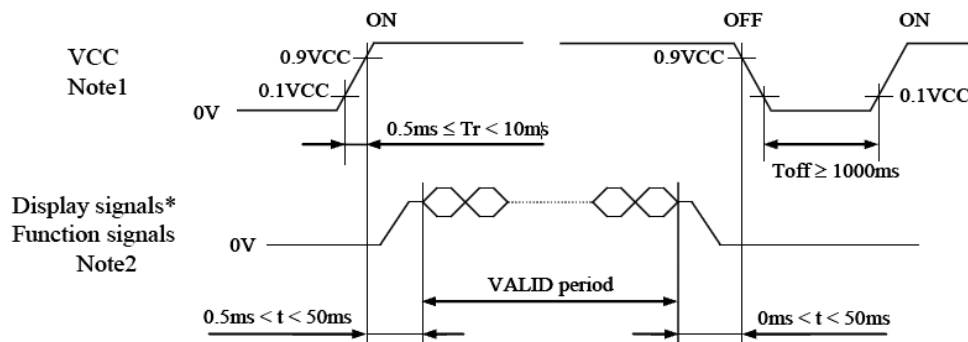

* These signals should be measured at the terminal of 100Ω resistance.

Note1: If there is a voltage variation(voltage drop) at the rising edge of VCC below 3.0V,there is a possibility that a product does not work due to a protection circuit.

Note2: Display signals (RIN0±,RIN1±,RIN2±,RIN3± and CLKIN±) and function signals(DPS and FRC) must be set to Low or High-impedance, except the VALID period (See above sequence diagram),in order to avoid the circuitry damage .If some of display and function signals of this product are cut while this product is working, even if the signal input to it once again, it might not work normally. If a customer stops the display and function signals, VCC also must be shut down.

5.3.2 LED Driver

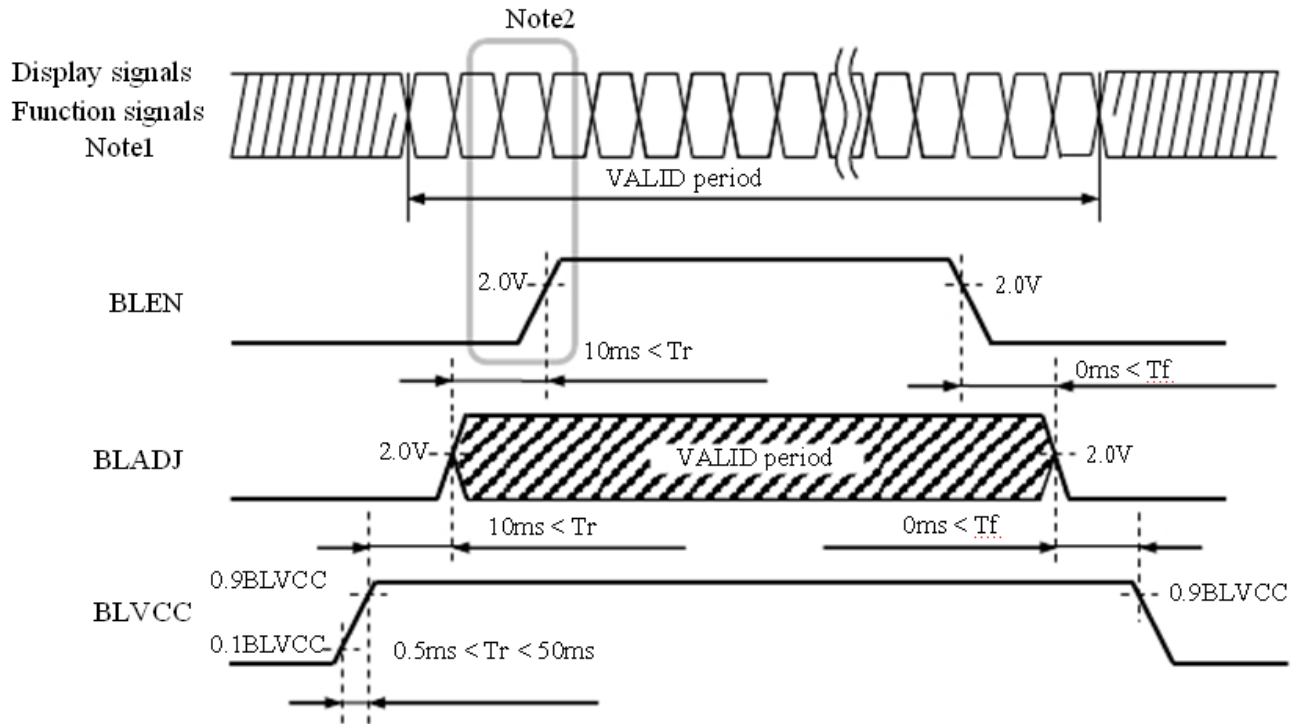

Note1: These are the display and function signals for LCD panel signal processing board.

Note2: The backlight should be turned on within the valid period of display and function signals, in order to avoid unstable data display.

6. AC Characteristics

6.1 Input data mapping

6.1.1 LVDS Input data signal: 8-bit

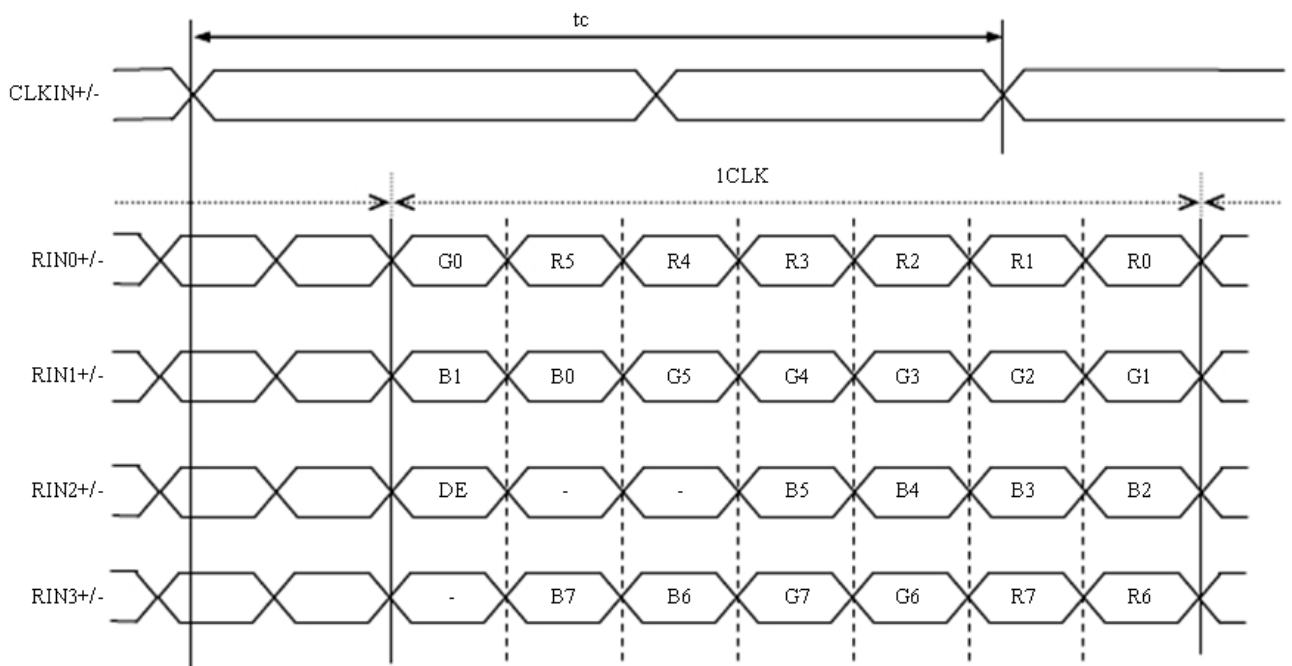

6.1.2 LVDS Input data signal:6-bit

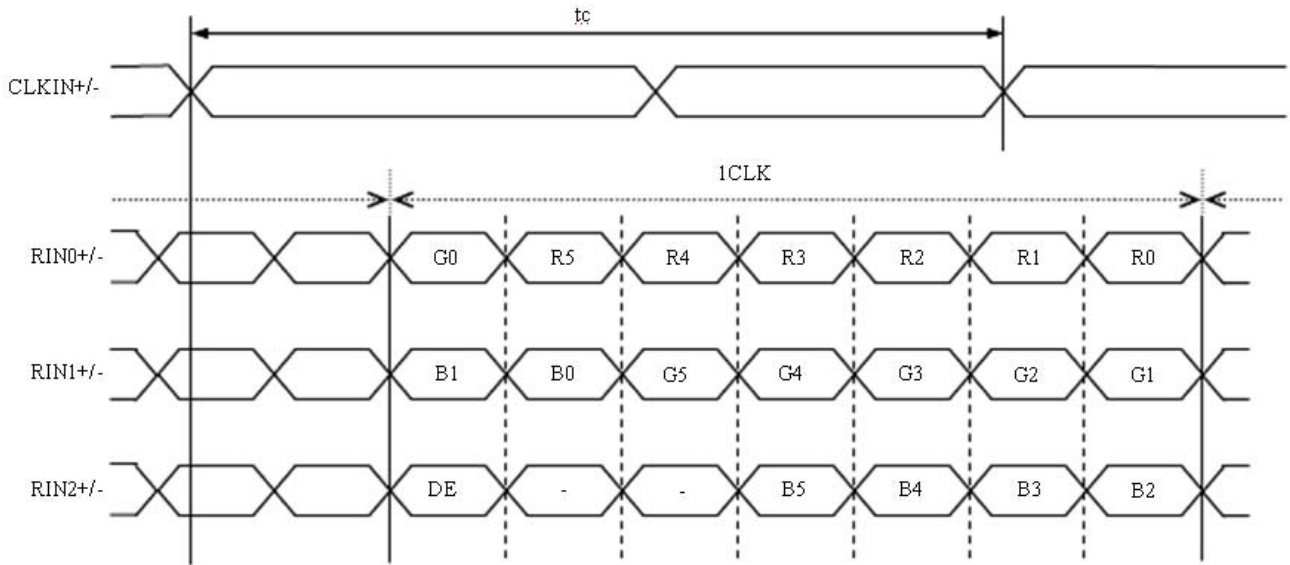

6.2 Timing Characteristics

(Note1,Note2,Note3)

Parameter		Symbol	MIN.	TYP.	MAX.	Unit	Remarks	
CLK	Frequency	1/tc	52.0	65.0	71.0	MHz	15.385ns (typ.)	
	Duty ratio	-				-	-	
	Rise time, Fall time	-				ns	-	
DATA	CLK-DATA	Setup time	-			ns	-	
		Hold time	-			ns	-	
	Rise time, Fall time	-				ns	-	
DE	Horizontal	Cycle	th	16.542	20.676	26.88	us	48.363kHz (typ.)
				1114	1344	1400	CLK	
		Display period	thd	1024			CLK	-
	Vertical (One frame)	Cycle	tv	13.34	16.666	20.0	ms	60.0Hz (typ.)
				780	806	845	H	
		Display period	tvd	768			H	
CLK-DE	Setup time	-			-	ns	-	
	Hold time	-			-	ns	-	
Rise time, Fall time		-				ns	-	

Note1:Definition of parameter is as follows.

tc = 1CLK, th = 1H

Note2:See the data sheet of LVDS transmitter.

Note3:Vertical cycle (tv) should be specified in integral multiple of Horizontal cycle (th).

6.3 Input signal timing chart

Horizontal timing

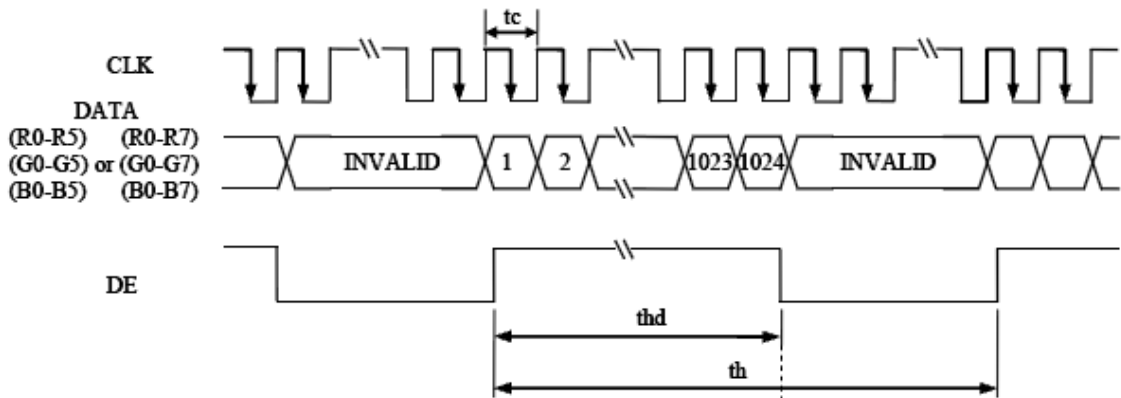

Vertical timing

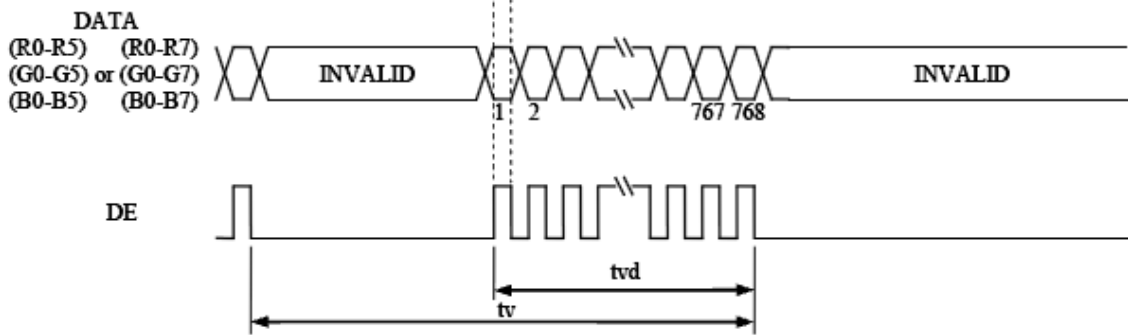

7. Optical Characteristics

(Note*1,*2)

Parameter	Condition	Symbol	min.	typ.	max.	Unit	Measuring instrument	Remarks	
Luminance	White at center $\theta R=0^\circ, \theta L=0^\circ, \theta U=0^\circ, \theta D=0^\circ$	L	300	450	-	cd/m ²	BM-5A	-	
Contrast ratio	White/Black at center $\theta R=0^\circ, \theta L=0^\circ, \theta U=0^\circ, \theta D=0^\circ$	CR	500	700	-	-	BM-5A	Note3	
Luminance uniformity	White $\theta R=0^\circ, \theta L=0^\circ, \theta U=0^\circ, \theta D=0^\circ$	LU	-	1.25	(1.33)	-	BM-5A	Note6	
Chromaticity	White	x coordinate	Wx	0.263	0.313	0.363	-	SR-3	Note5
		y coordinate	Wy	0.279	0.329	0.379	-		
	Red	x coordinate	Rx	-	TBD	-	-		
		y coordinate	Ry	-	TBD	-	-		
	Green	x coordinate	Gx	-	TBD	-	-		
		y coordinate	Gy	-	TBD	-	-		
Blue	x coordinate	Bx	-	TBD	-	-			
	y coordinate	By	-	TBD	-	-			
Color gamut	$\theta R=0^\circ, \theta L=0^\circ, \theta U=0^\circ, \theta D=0^\circ$ at center, against NTSC color space	C	48	55	-	%			
Response time	White to Black	Ton	-	(3)	(5)	ms	BM-5A -10000	Note4	
	Black to White	Toff	-	(5)	(8)	ms			
Viewing angle	Right	$\theta U=0^\circ, \theta D=0^\circ, CR \geq 10$	θR	70	80	-	EZ Contrast	Note2	
	Left	$\theta U=0^\circ, \theta D=0^\circ, CR \geq 10$	θL	70	80	-			
	Up	$\theta R=0^\circ, \theta L=0^\circ, CR \geq 10$	θU	70	80	-			
	Down	$\theta R=0^\circ, \theta L=0^\circ, CR \geq 10$	θD	70	80	-			

Note:

*1. The value above are initial Characteristics.

* 2: Measurement conditions are as follows.

Ta= 25°C, VCC= 3.3V, VDD= 12.0V, PWM duty ratio: 100%,

Display mode: XGA, Horizontal cycle= 1/48.363kHz, Vertical cycle= 1/60.0Hz,

DPS= Low or Open: Normal scan, FRC= High

Note 1:

The data are measured after LEDs are turned on for 5 minutes. LCM displays full white. The brightness is the average value of 9 measured spots. Measurement equipment SR-3A (1°)
 Measuring condition:

- Measuring surroundings: Dark room
- Measuring temperature: Ta=25°C.
- Adjust operating voltage to get optimum contrast at the center of the display.

Note 2:

The definition of viewing angle: Refer to the graph below marked by θ and ϕ

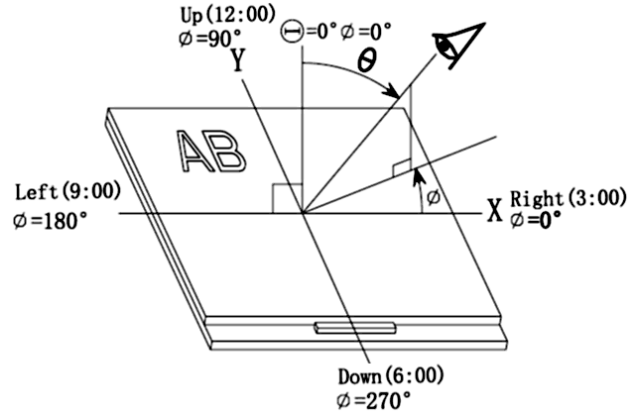

Note 3:

The definition of contrast ratio (Test LCM using SR-3A (1°)):

$$\text{Contrast Ratio (CR)} = \frac{\text{Luminance When LCD is at "White" state}}{\text{Luminance When LCD is at "Black" state}}$$

(Contrast Ratio is measured in optimum common electrode voltage)

Note 4:

Definition of Response time. (Test LCD using BM-7A(2°)):

The output signals of photo detector are measured when the input signals are changed from "black" to "white"(falling time) and from "white" to "black"(rising time), respectively. The response time is defined as the time interval between the 10% and 90% of amplitudes. Refer to figure as below.

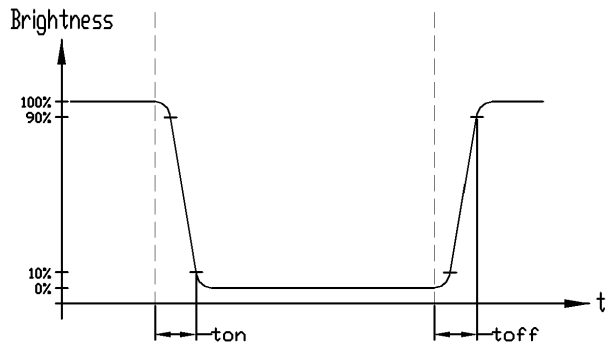

Note 5:

Definition of Color of CIE1931 Coordinate and NTSC Ratio.

Color gamut:

$$S = \frac{\text{Area of RGB triangle}}{\text{Area of NTSC triangle}} \times 100\%$$

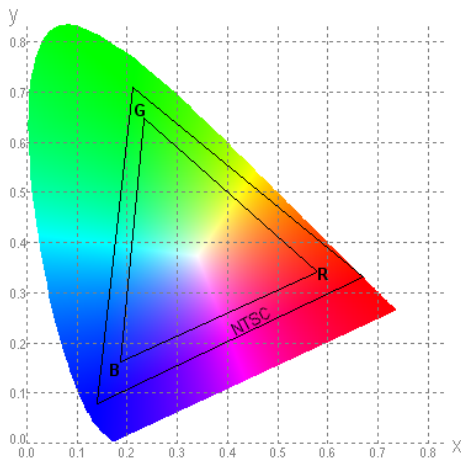

Note 6:

The luminance uniformity is calculated by using following formula.

$$\Delta Bp = Bp (\text{Min.}) / Bp (\text{Max.}) \times 100 (\%)$$

Bp (Max.) = Maximum brightness in 9 measured spots

Bp (Min.) = Minimum brightness in 9 measured spots.

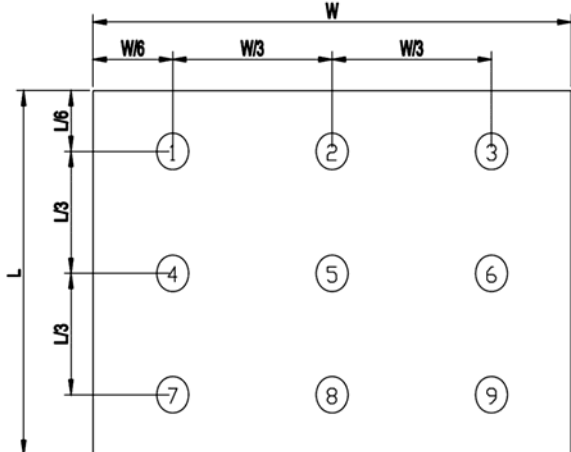

Note 7:

Measured the luminance of white state at center point

8. Precautions of using LCD Modules

Mounting

- Mounting must use holes arranged in four corners or four sides.
- The mounting structure so provide even force on to LCD module. Uneven force (ex. Twisted stress) should not applied to the module. And the case on which a module is mounted should have sufficient strength so that external force is not transmitted directly to the module.
- It is suggested to attach a transparent protective plate to the surface in order to protect the polarizer. It should have sufficient strength in order to the resist external force.
- The housing should adopt radiation structure to satisfy the temperature specification.
- Acetic acid type and chlorine type materials for the cover case are not desirable because the former generates corrosive gas of attacking the polarizer at high temperature and the latter causes circuit break by electro-chemical reaction.
- Do not touch, push or rub the exposed polarizers with glass, tweezers or anything harder than HB pencil lead. Never rub with dust clothes with chemical treatment. Do not touch the surface of polarizer for bare hand or greasy cloth.(Some cosmetics deteriorate the polarizer.)
- When the surface becomes dusty, please wipe gently with absorbent cotton or other soft materials like chamois soaks with petroleum benzine. Normal-hexane is recommended for cleaning the adhesives used to attach front / rear polarizers. Do not use acetone, toluene and alcohol because they cause chemical damage to the polarizer.
- Wipe off saliva or water drops as soon as possible. Their long time contact with polarizer

Operating

- The spike noise causes the mis-operation of circuits. It should be within the $\pm 200\text{mV}$ level (Over and under shoot voltage)
- Response time depends on the temperature.(In lower temperature, it becomes longer.)
- Brightness depends on the temperature. (In lower temperature, it becomes lower.) And in lower temperature, response time(required time that brightness is stable after turned on) becomes longer.
- Be careful for condensation at sudden temperature change. Condensation makes damage to polarizer or electrical contacted parts. And after fading condensation, smear or spot will occur.
- When fixed patterns are displayed for a long time, remnant image is likely to occur.
- Module has high frequency circuits. Sufficient suppression to the electromagnetic interference shall be done by system manufacturers. Grounding and shielding methods may be important to minimized the interference

Electrostatic Discharge Control

Since a module is composed of electronic circuits, it is not strong to electrostatic discharge. Make certain that treatment persons are connected to ground through wrist band etc. And don't touch interface pin directly.

Strong Light Exposure

Strong light exposure causes degradation of polarizer and color filter.

Storage

When storing modules as spares for a long time, the following precautions are necessary.

- Store them in a dark place. Do not expose the module to sunlight or fluorescent light. Keep the temperature between 5°C and 35°C at normal humidity.
- The polarizer surface should not come in contact with any other object. It is recommended that they be stored in the container in which they were shipped.

Protection Film

- When the protection film is peeled off, static electricity is generated between the film and polarizer. This should be peeled off slowly and carefully by people who are electrically grounded and with well ion-blown equipment or in such a condition, etc.
- The protection film is attached to the polarizer with a small amount of glue. If some stress is applied to rub the protection film against the polarizer during the time you peel off the film, the glue is apt to remain on the polarizer. Please carefully peel off the protection film without rubbing it against the polarizer.
- When the module with protection film attached is stored for a long time, sometimes there remains a very small amount of glue still on the polarizer after the protection film is peeled off.
- You can remove the glue easily. When the glue remains on the polarizer surface or its vestige is recognized, please wipe them off with absorbent cotton waste or other soft material like chamois soaked with normal-hexane.

Transportation

The LCD modules should be no falling and violent shocking during transportation, and also should avoid excessive press, water, damp and sunshine.